

RX170Q

**Intel® Q170 support 6th / 7th generation Core™ i7/ i5 /i3 CPU
Micro-ATX Motherboard**

User's Manual

Ver. 2.1

Contents

Safety Information	5
About this guide	7
Typography	8
Packing List	9
Revision History	10
Specifications Summary	11
Chapter 1 – Product Introduction	14
1.1 Before you Proceed.....	14
1.2 Motherboard Overview	14
1.2.1 Placement Direction	14
1.2.2 Screw Holes	15
1.2.3 Motherboard Layout	15
1.2.4 Layout Content List	16
1.3 Central Processing Unit (CPU).....	17
1.3.1 Installing the CPU	18
1.3.2 Installing the CPU Heatsink and Fan	20
1.3.3 Uninstalling the CPU Heatsink and Fan.....	22
1.4 System Memory.....	24
1.4.1 Overview	24
1.4.2 Installing a DIMM	24
1.4.3 Removing a DIMM	25
1.5 Expansion Card.....	25
1.5.1 Installing an Expansion Card	25
1.5.2 Configuring an Expansion Card	25
1.5.3 PCI Express x16 slot.....	25
1.5.4 PCI Express X1 slot	26
1.5.5 Mini PCIe connector.....	26
1.5.6 M.2 connector	27
1.6 Jumpers.....	27
1.6.1 Clear CMOS (JCMOS1).....	27
1.6.2 AT/ATX Power Mode Select (JPSON1).....	28
1.6.3 COM POWER SETTING(JCOMPWR1~5)	29
1.6.4 COM6 Master/Slave terminal Setting(COM6_S1~4)	30
1.6.5 COM6 type setting(JSETCOM6).....	30
1.6.6 LVDS panel voltage Selection (JBLVOL1).....	31
1.6.7 LVDS brightness control mode selection(JLVDS_BKL1)	31
1.7 Connectors	31
1.7.1 Rear panel connectors	32

1.7.2 CPU and System fan connectors (CPU_FAN, SYS_FAN)	33
1.7.3 System Panel (F_PANEL).....	34
1.7.4 ATX power connectors (EATXPWR1 & ATX12V1).....	35
1.7.5 Serial Port connectors (COM1~5)	36
1.7.6 Serial ATA Connector (SATA1~6).....	37
1.7.7 USB connectors (USB910, USB1112).....	37
1.7.8 USB connector (USB13)	38
1.7.9 USB3.0 connector(USB56)	359
1.7.10 LPT Port Connector(LPT).....	40
1.7.11 LAN LED Status connector(LANLED1).....	40
1.7.12 8 bit GPIO header(JDIO1).....	40
1.7.13 Front Audio connector (FP_AUDIO1)	41
1.7.14 Amplifier Connector(JAMP1).....	42
1.7.15 LVDS back light connector(JBKL1).....	42
1.7.16 LVDS connector(CN3).....	43
1.7.17 SM bus connector(JSMB1)	43
Chapter 2 – BIOS Setup	44
2.1 BIOS Setup Program	45
2.1.1 Legend Box	46
2.1.2 List Box.....	46
2.1.3 Sub-menu.....	45
2.2 BIOS Menu Screen.....	47
2.3 Main Setup.....	47
2.4 Advanced BIOS Setup.....	48
2.4.1 Trusted Computing(optional).....	50
2.4.2 ACPI settings.....	51
2.4.3 AMT configuration	52
2.4.4 PCH-FW configuration	52
2.4.5 NTC6101D Super IO configuration	54
2.4.6 NTC6106D HW moinitor.....	60
2.4.7 S5 RTC wake settings.....	63
2.4.8 CPU configuration	64
2.4.9 Intel TXT information	65
2.4.10 SATA Configuration.....	67
2.4.11 AMI Graphic Output Protocol Policy.....	69
2.4.12 Network Stack Configuration.....	70
2.4.13 Compatibility Support Module Configuration.....	71
2.4.14 NVMe Configuration	72
2.4.15 USB Configuration.....	72

RX170Q User's Manual

2.5 Chipset	73
2.5.1 System Agent (SA) Configuration	74
2.5.2 PCH-IO Configuration	81
2.6 Security.....	90
2.7 Boot	891
2.8 Save & Exit	901

Safety Information

Electrical safety

- To prevent electrical shock hazard, disconnect the power cable from the electrical outlet before relocating the system.
- When adding or removing devices to or from the system, ensure that the power cables for the devices are unplugged before the signal cables are connected. If possible, disconnect all power cables from the existing system before you add a device.
- Before connecting or removing signal cables from the motherboard, ensure that all power cables are unplugged.
- Seek professional assistance before using an adapter or extension cord. These devices could interrupt the grounding circuit.
- Make sure that your power supply is set to the correct voltage in your area. If you are not sure about the voltage of the electrical outlet you are using, contact your local power company.
- If the power supply is broken, do not try to fix it by yourself. Contact a qualified service technician or your retailer.

Operation safety

- Before installing the motherboard and adding devices on it, carefully read all the manuals that came with the package.
- Before using the product, make sure all cables are correctly connected and the power cables are not damaged. If you detect any damage, contact your dealer immediately.
- To avoid short circuits, keep paper clips, screws, and staples away from connectors, slots, sockets and circuitry.
- Avoid dust, humidity, and temperature extremes. Do not place the product in any area where it may become wet.
- Place the product on a stable surface.
- If you encounter technical problems with the product, contact a qualified service technician or your retailer.



The symbol of the crossed out wheeled bin indicates that the product (electrical and electronic equipment) should not be placed in municipal waste. Check local regulations for disposal of electronic products.

Safety Declaration

This device complies with the requirements in Part 15 of the FCC rules. Operation is subject to the following two conditions:

- This device may not cause harmful interference.
- This device must accept any interference received, including interference that may cause undesired operation.

About this guide

This user guide contains the information you need when installing and configuring the motherboard.

How this guide is organized

This manual contains the following parts:

- **Chapter 1: Product introduction**

This chapter describes the features of the motherboard and the new technology it supports. This chapter also lists the hardware setup procedures that you have to perform when installing system components. It includes description of the jumpers and connectors on the motherboard.

- **Chapter 2: BIOS setup**

This chapter tells how to change system settings through the BIOS Setup menus. Detailed descriptions of the BIOS parameters are also provided.

Where to find more information

Refer to the following sources for additional information and for product and software updates.

1. Technical Support

If a problem arises with your system and no solution can be obtained from the user's manual, please contact your place of purchase or local distributor.

2. Optional documentation

Your product package may include optional documentation, such as warranty flyers, that may have been added by your dealer. These documents are not part of the standard package.

Conventions used in this guide

To make sure that you perform certain tasks properly, take note of the following symbols used throughout this manual.



DANGER/WARNING: Information to prevent injury to yourself when trying to complete a task.



CAUTION: Information to prevent damage to the components when trying to complete a task.



IMPORTANT: Instructions that you **MUST** follow to complete a task.



NOTE: Tips and additional information to help you complete a task.

Typography

Bold text	Indicates a menu or an item to select
<i>Italics</i>	Used to emphasize a word or a phrase
<Key>	Keys enclosed in the less-than and greater-than sign means that you must press the enclosed key Example: <Enter> means that you must press the Enter or Return key
<Key1>+<Key2>+<Key3>	If you must press two or more keys simultaneously, the key names are linked with a plus sign (+) Example: <Ctrl>+<Alt>+<D>
Command	Means that you must type the command exactly as shown, then supply the required item or value enclosed in brackets Example: At the DOS prompt, type the command line: afudos /i[filename] afudos /71163100.ROM

Packing List

Before you begin installing your single board, please make sure that the following materials have been shipped:

- 1 x RX170Q Micro-ATX Main board
- 1 x I/O Shield



If any of the above items is damaged or missing, please contact your retailer.

Revision History

Revision	Revision History	Date
V 0.1	First release version	Nov. , 2015
V 0.2	2 nd version with BIOS setup description	Jan. , 2016
V 1.0	Update LAN LED header signal description	May. , 2016
V 2.0	Update Intel latest 7 th generation processor supports, ME version 11.6.10.1196	Mar. , 2017
V2.1	Correct memory description typo	Feb., 2019

Specifications Summary

Specifications	
System	
CPU	Intel LGA1151 socket supports Intel Core i7/ i5/ i3 6xxx/ 7xxxx CPU
BIOS	AMI 64Mb SPI
System Chipset	Intel® Q170
Memory	4 x 30μ Gold Plated DIMM Up to 64GB Dual Channel DDR4 2133Mhz Optional ECC Memory Support
Watchdog Timer	1 ~ 255 sec timer
H/W Status Monitor	CPU & system temperature monitoring Voltages monitoring
Expansion Slots	1 x PCIe x 16 Slot (Slot One) (Black) 1 x PCIe x 4 Slot (x16 Physical Slot) (Slot Three) (Yellow) 2 x PCIe x 1 Slot Open End (Slot Two & Four) 1 x Full/Half Size Mini-PCIe 1 x M.2 Slot (with PCIe x4 & SATA III)
Smart Fan Control	Yes
Display	
Chipset	Intel® Integrated Graphic (CPU Dependent)
Display Memory	Shared Memory
Ethernet	
LAN1	Intel® i219-LM PHY LAN Controller (intel iAMT 10.0 support)
Back I/O Port	
Back Panel	1 x PS/2 & 2 x USB 2.0 Combo Connector 1 x RS-232/422/485 Connector 1 x DVI-D Connector 2 x DisplayPort Connector 2 x Stack up RJ45 and USB 3.0 Connectors 1 x 3 Jacks Audio Connector
Internal I/O Connector	
Internal I/O	5 x SATAIII connectors(RED) & 1 x SATAIII connectors(Black) shared with M.2 4 x USB 2.0 headers support 8 ports 1 x USB 3.0 header support 2 ports 5 x RS232 pin 2.00 mm headers 1 x LVDS header 1x eDP header(optional) 1 x Backlight Locking Type Header 1 x LPC Header 1 x SPI Header

RX170Q User's Manual

	1 x Front Audio Header with Shroud 1 x Amplifier Locking Type Header 1 x CPU Fan connector 2 x chassis Fan connector 1 x Front panel header 1 x 8 bits GPIO Header with Shroud 1 x Printer port 2 x LAN Status LED Headers 1 x Horizontal Socket Type CMOS Battery Holder 1 x Chassis Intrusion Locking Type Header 1 x 24-pin ATX Power connector 1 x 4-pin ATX 12V Power connector
Mechanical & Environmental	
Operating Temperature	0~60°C (32~140°F)
Operating Humidity	5%~90% relative humidity, non-condensing
Size (L x W)	9.6 inch x 9.6 inch

Block Diagram

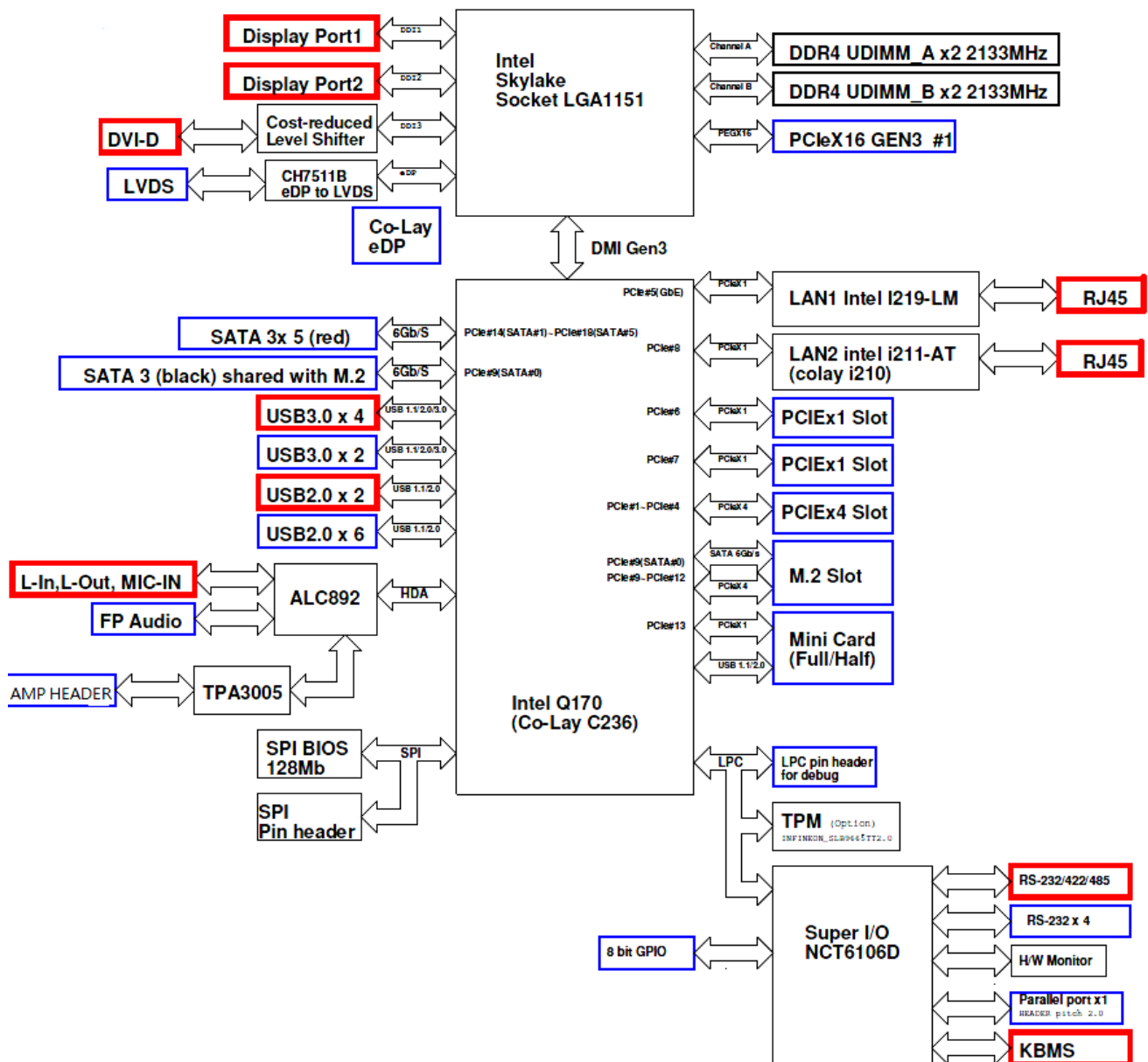

Chapter 1 - Product Introduction

1.1 Before you Proceed

Take note of the following precautions before you install motherboard components or change any motherboard settings.



- Unplug the power cord from the wall socket before touching any component.
- Use a grounded wrist strap or touch a safely grounded object or a metal object, such as the power supply case, before handling components to avoid damaging them due to static electricity
- Hold components by the edges to avoid touching the ICs on them.
- Whenever you uninstall any component, place it on a grounded anti-static pad or in the bag that came with the component.
- Before you install or remove any component, ensure that the ATX power supply is switched off or the power cord is detached from the power supply. Failure to do so may cause severe damage to the motherboard, peripherals, and/or components.

1.2 Motherboard Overview

Before you install the motherboard, study the configuration of your chassis to ensure that the motherboard fits into it. Refer to the chassis documentation before installing the motherboard.



Make sure to unplug the power cord before installing or removing the motherboard. Failure to do so can cause you physical injury and damage motherboard components.

1.2.1 Placement Direction

When installing the motherboard, make sure that you place it into the chassis in the correct orientation. The edge with external ports goes to the rear part of the chassis as indicated in the image below.

1.2.2 Screw Holes

Place eight (8) screws into the holes indicated by circles to secure the motherboard to the chassis.



Do not over tighten the screws! Doing so can damage the motherboard.

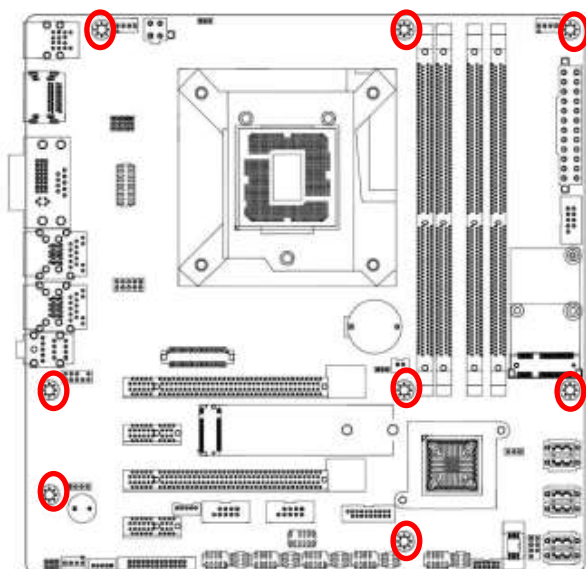

Place this side towards the rear of the chassis.

1.2.3 Motherboard Layout

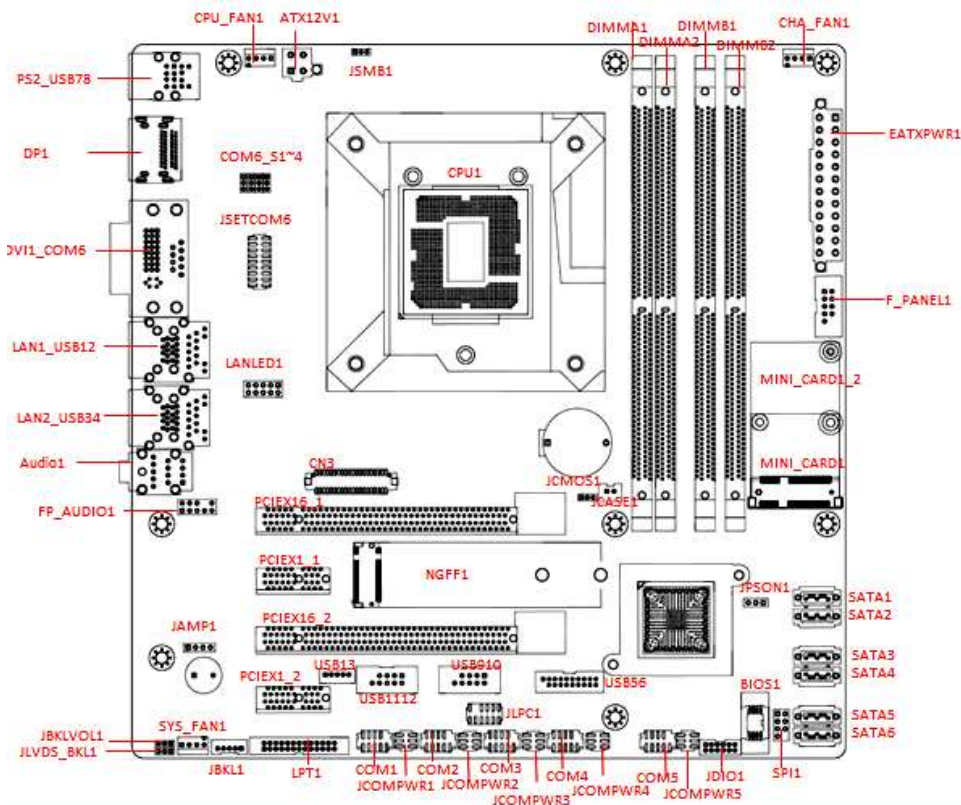

RX170Q User's Manual

1.2.4 Layout Content List

Slots & socket			
Label	Function	Note	
CPU1	LGA1151 socket		
DIMMA1~B2	DDR4 DIMM Slot A1~B2		
PCIEX16_1~2	PCI-e x16 Slot		
PCIEX1_1~2	PCI-e x1 Slot		
Jumpers			
Label	Function	Note	
JCMOS1	Clear CMOS	3 x 1 header, pitch 2.00mm	
JPERSON1	AT/ATX Mode Select	3 x 1 header, pitch 2.54mm	
COM6_S1~4	master/slave terminal Select	2 x 1 header, pitch 2.00mm	
JSETCOM6	RS232/RS485/RS422 Select	2 x9 header, pitch 2.00mm	
JBKLVOL1	LVDS voltage Selection	3 x 1 header, pitch 2.00mm	
JLVDS_BKL1	LVDS brightness control mode Selection	3 x 1 header, pitch 2.00mm	
JCOMPWR1~5	COM1~5 POWER SETTING	3 x 2 header, pitch 2.00mm	

Rear Panel Connector			
Label	Function	Note	
PS2_USB78	PS/2 & 2 x USB 2.0 Combo Connector		
DP1	2 Display port connector		
DVI1_COM6	DVI-D+ COM connector		
LAN1_USB12	RJ-45 Ethernet Connector x 1 USB 3.0 Connector x 2		
LAN2_USB34	RJ-45 Ethernet Connector x 1 USB 3.0 Connector x 2		
AUDIO1	3 audio phone jack		

Internal Connector			
Label	Function	Note	
CPU_FAN1	CPU Fan Connector	4 x 1 wafer, pitch 2.54mm	
SYS_FAN1	System Fan Connector	4 x 1 wafer, pitch 2.54mm	
CHA_FAN1	Chassis FAN connector	4 x 1 wafer, pitch 2.54mm	
F_PANEL	Intel Front Panel connector	5 x 2 header, pitch 2.54mm	
EATXPWR1	ATX power connectors	12 x 2 wafer	
ATX12V1	12V ATX power connectors	2 x 2 wafer	

COM1 ~ 5	Serial Port Connector	5 x 2 header, pitch 2.00mm
SATA1 ~ 6	SATA Data Connector	7P Male connector
USB910/1112	USB Connector	5 x 2 header, pitch 2.54mm
LPT1	Print Port Connector	13 x 2 wafer, pitch 2.54mm
USB56	USB 3.0 connector	10 x 2 header, pitch 2.54mm
JBKL1	Backlight connector	5 x 1 wafer, pitch 2.00mm
CN3	LVDS connector	40 x 2 wafer, pitch 1.25mm
JSMB1	SM bus connector	3 x 1 header, pitch 2.00mm
MINI_CARD1	Mini PCIe connector	Support full/half-length miniPCIe card
NGFF1	M.2 connector	

1.3 Central Processing Unit (CPU)

The motherboard comes with a surface mount LGA1151 socket designed for the Intel® Core™ i7/ i5/ i3 processor in the 1151-land package.

- Your boxed Intel® Core™ i7/ i5/ i3 LGA1155 processor package should come with installation instructions for the CPU, fan and heatsink assembly. If the instructions in this section do not match the CPU documentation, follow the latter.
- Upon purchase of the motherboard, make sure that the PnP cap is on the socket and the socket pins are not bent. Contact your retailer immediately if the PnP cap is missing, or if you see any damage to the PnP cap/socket pins/motherboard components. BCM Advanced Research will shoulder the cost of repair only if the damage is shipment/transit-related.
- Keep the cap after installing the motherboard. BCM Advanced Research will process Return Merchandise Authorization (RMA) requests only if the motherboard comes with the cap on the LGA1151 socket.
- The product warranty does not cover damage to the socket pins resulting from incorrect CPU installation/removal, or misplacement/loss/incorrect removal of the PnP cap.
- Install the CPU fan and heatsink assembly before you install motherboard to the chassis.



If you purchased a separate CPU heatsink and fan assembly, make sure that you have properly applied Thermal Interface Material to the CPU heatsink or CPU before you install the heatsink and fan assembly.



1.3.1 Installing the CPU

1. Locate the CPU socket on the motherboard.

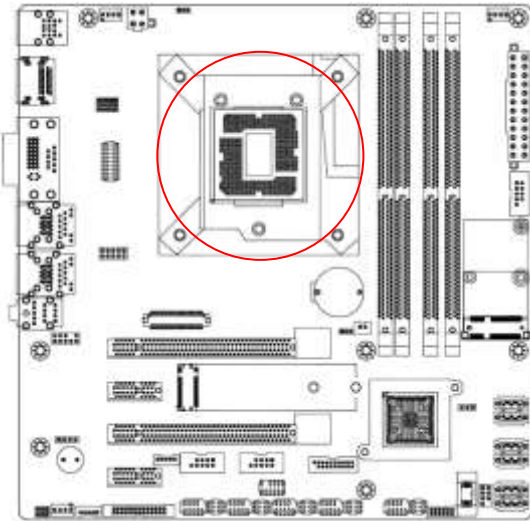

Before installing the CPU, make sure that the socket box is facing towards you and the load lever is on your left.

2. Press the load lever with your thumb (A), then move it to the left (B) until it is released from the retention tab.

Retention tab

Load lever

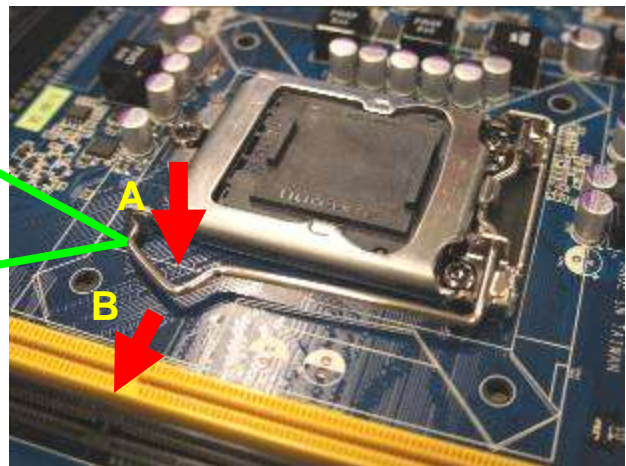
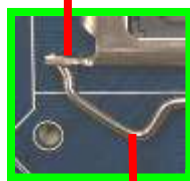

To prevent damage to the socket pins, do not remove the PnP cap unless you are installing a CPU. Save PnP cap in the even the CPU require to be remove from the board.

3. Lift the Load lever with your thumb and forefinger to around 180° angle (A), then pull the PnP cap from the CPU socket to remove (B).

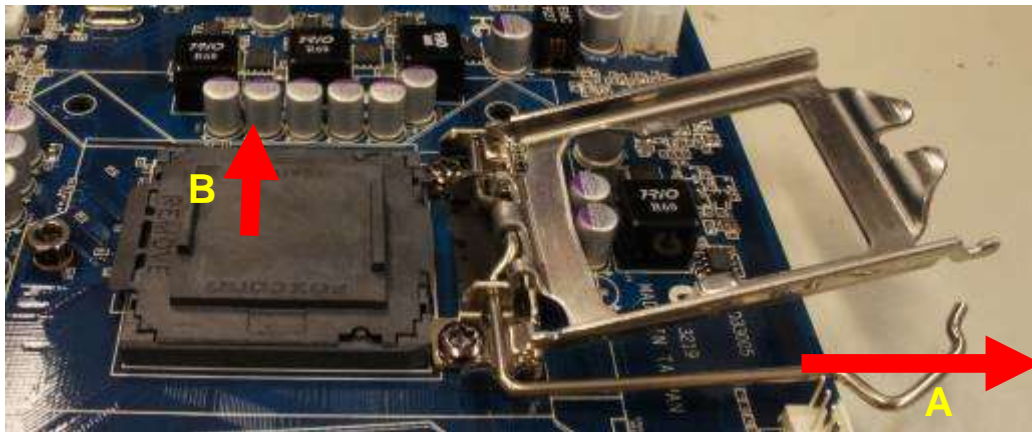

4. Position the CPU over the socket, making sure that the gold triangle is on the top-left corner of the socket then fit the socket alignment key into the CPU notch.

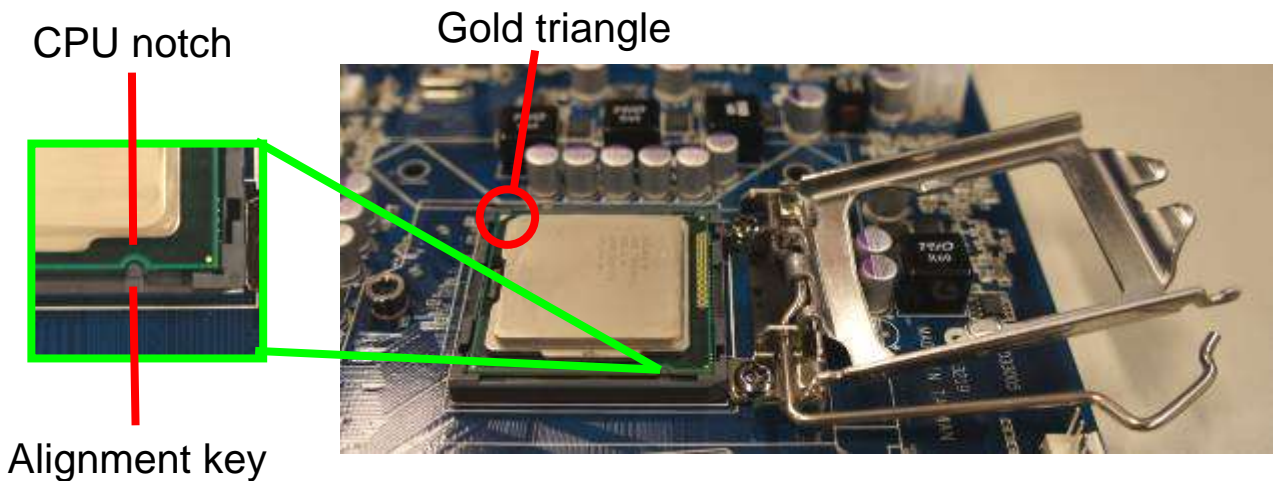

5. Pull back the load lever , then push the load lever (A) until it snaps into the retention tab.



The CPU fits in only one correct orientation. DO NOT force the CPU into the socket to prevent bending the connectors on the socket and damaging the CPU!

1.3.2 Installing the CPU Heatsink and Fan

Intel® Core™ i7/ i5/ i3 LGA1151 processor requires a specially designed heatsink and fan assembly to ensure optimum thermal condition and performance.



- Install the motherboard to the chassis before you install the CPU fan and heatsink assembly.
- When you buy a boxed Intel® Core™ i7/ i5/ i3 LGA1151 processor, the package includes the CPU fan and heatsink assembly. If you buy a CPU separately, make sure that you use only Intel® certified multi-directional heatsink and fan.
- Your Intel® Core™ i7/ i5/ i3 LGA1151 processor LGA1151 heatsink and fan assembly comes in a push-pin design and requires no tool to install.



If you purchased a separate CPU heatsink and fan assembly, make sure that you have properly applied Thermal Interface Material to the CPU heatsink or CPU before you install the heatsink and fan assembly.

To install the CPU heatsink and fan:

1. Place the heatsink on top of the installed CPU, making sure that the four fasteners match the holes on the motherboard.

Narrow end of the groove

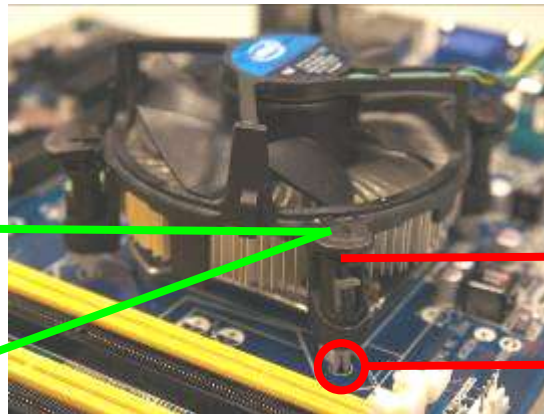
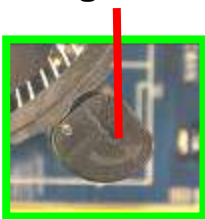

Fastener

Motherboard hole



Orient the heatsink and fan assembly such that the CPU fan cable is closest to the CPU fan connector.



- Make sure each fastener is oriented as shown, with the narrow groove directed outward.

2. Push down two fasteners at a time in a diagonal sequence to secure the heatsink and fan assembly in place.

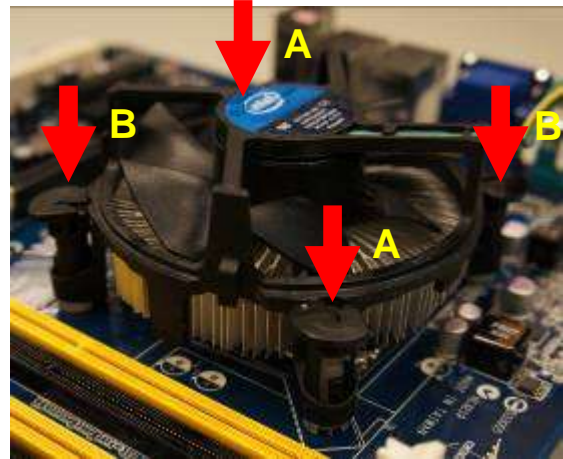
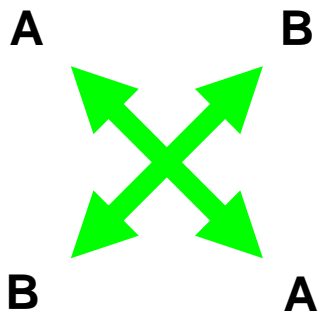

3. Connect the CPU fan cable to the connector on the motherboard labeled CPU_FAN.

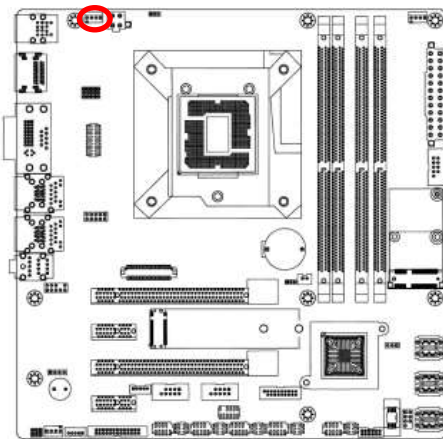

FAN 1
CPU FAN

- | | |
|---|---------------|
| ○ | 4. FAN_PWM1_C |
| ○ | 3. FANCPUDEC1 |
| ○ | 2. +V12 |
| □ | 1. GND |

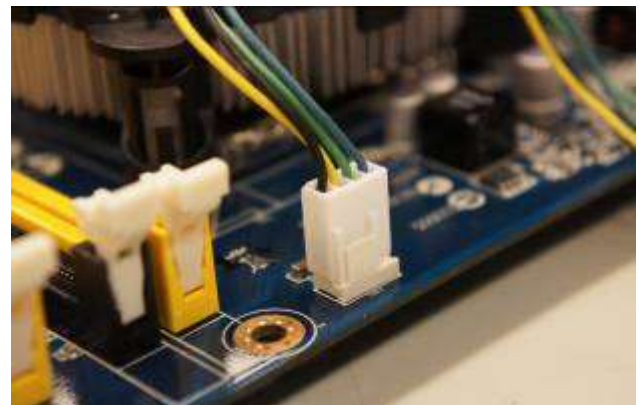

Do not forget to connect the fan cables to the fan connectors. Insufficient air flow inside the system may damage the motherboard components.

These are not jumpers! DO NOT place jumper caps on the fan connectors.

1.3.3 Uninstalling the CPU Heatsink and Fan

To uninstall the CPU heatsink and fan:

1. Disconnect the CPU fan cable from the connector on the motherboard.
2. Rotate each fastener counterclockwise

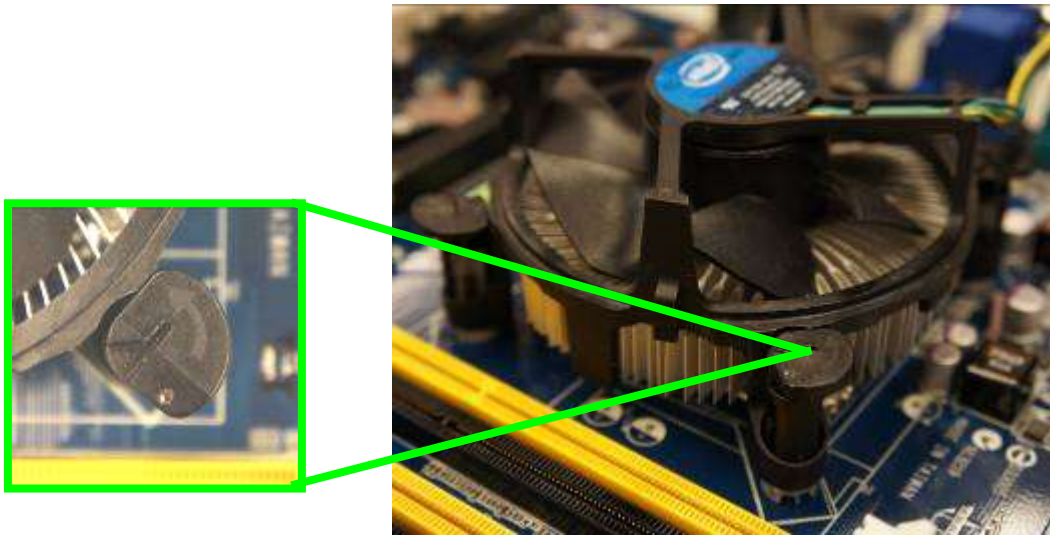

3. Pull up two fasteners at a time in a diagonal sequence to disengage the heatsink and fan assembly from the motherboard.

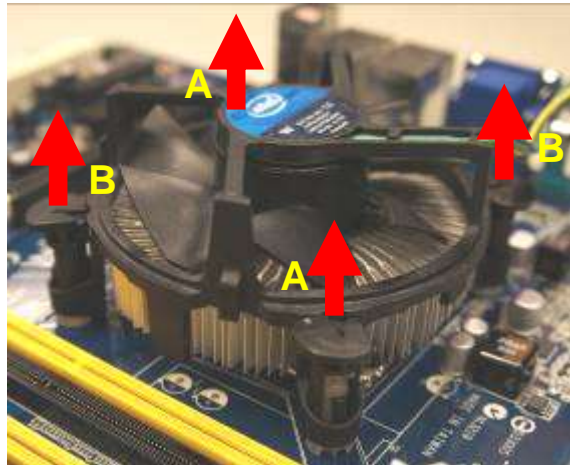
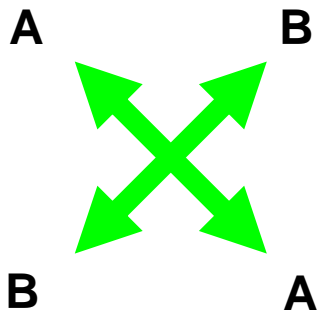

4. Carefully remove the heatsink and fan assembly from the motherboard.



5. Rotate each fastener clockwise to ensure correct orientation when reinstalling.



1.4 System Memory

1.4.1 Overview

The motherboard comes with four 288-pin Double Data Rate 4 (DDR4) Dual Inline Memory Modules (DIMM) sockets.

DDR4 SDRAM, an abbreviation for double data rate fourth generation synchronous dynamic random-access memory, is a type of synchronous dynamic random-access memory (SDRAM) with a high bandwidth ("double data rate") interface. The primary advantages of DDR4 over its predecessor, DDR3, include higher module density and lower voltage requirements, coupled with higher data rate transfer speeds. DDR4 memory comes in 288-pin DIMM modules, similar in size to 240-pin DDR3 DIMMs. The pins are spaced more closely (0.85 mm instead of 1.0) to fit the increased amount within the same 5¼ inch (133.35 mm) standard DIMM length but, the height is increased slightly (31.25 mm/1.23 in instead of 30.35 mm/1.2 in) to make signal routing easier, and the thickness is also increased (to 1.2 mm from 1.0) to accommodate more signal layers. DDR4 DIMM modules have a slightly curved edge connector so not all of the pins are engaged at a time during module insertion, lowering the insertion force.

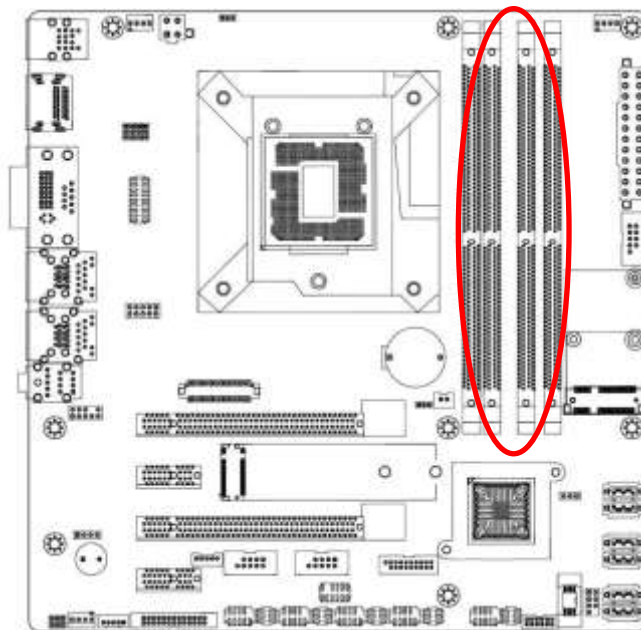

288-Pin DDR4 DIMM sockets

1.4.2 Installing a DIMM



Make sure to unplug the power supply before adding or removing DIMMs or other system components. Failure to do so may cause severe damage to both the motherboard and the components.

1. Locate the DIMM socket on the board.
2. Hold two edges of the DIMM module carefully, and keep away of touching its connectors.

3. Align the notch key on the module with the rib on the slot.
4. Firmly press the modules into the socket which will automatically snap into the mounting notch. Do not force the DIMM module in with extra force as the DIMM module only fits in one direction.

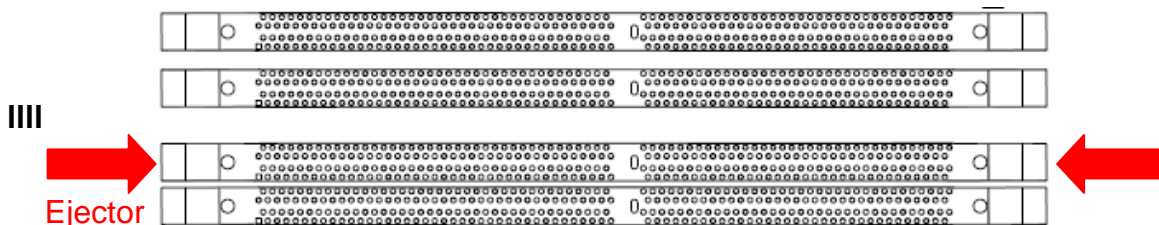

- A DDR4 DIMM is keyed with a notch so that it fits in only one direction. DO NOT force a DIMM into a socket to avoid damaging the DIMM.
- The DDR4 DIMM sockets do not support DDR/DDR2/DDR3 DIMMs. DO NOT install DDR/DDR2/DDR3 DIMMs to the DDR4 DIMM socket.

1.4.3 Removing a DDR4 DIMM

1. Press the two ejector tabs on the slot outward simultaneously, and then pull out the DIMM module.



Support the DIMM lightly with your fingers when pressing the ejector tabs. The DIMM might get damaged when it flips out with extra force.

1.5 Expansion Card

In the future, you may need to install expansion cards. The following sub-sections describe the slots and the expansion cards that they support.



Make sure to unplug the power cord before adding or removing expansion cards. Failure to do so may cause you physical injury and damage motherboard components.

1.5.1 Installing an Expansion Card

1. Before installing the expansion card, read the documentation that came with it and make the necessary hardware settings for the card.
2. Remove the system unit cover (if your motherboard is already installed in a chassis).
3. Remove the bracket opposite the slot that you intend to use. Keep the screw for later use.
4. Align the card connector with the slot and press firmly until the card is completely

RX170Q User's Manual

seated on the slot.

5. Secure the card to the chassis with the screw you removed earlier.
6. Replace the system cover.

1.5.2 Configuring an Expansion Card

After installing the expansion card, configure it by adjusting the software settings.

1. Turn on the system and change the necessary BIOS settings, if any. See Chapter 2 for information on BIOS setup.
2. Assign an IRQ to the card if needed. Refer to the tables on the next page.
3. Install the software drivers for the expansion card.

1.5.3 PCI Express x16 slot

This motherboard supports one PCI Express x16 slot that complies with the PCI Express specifications.

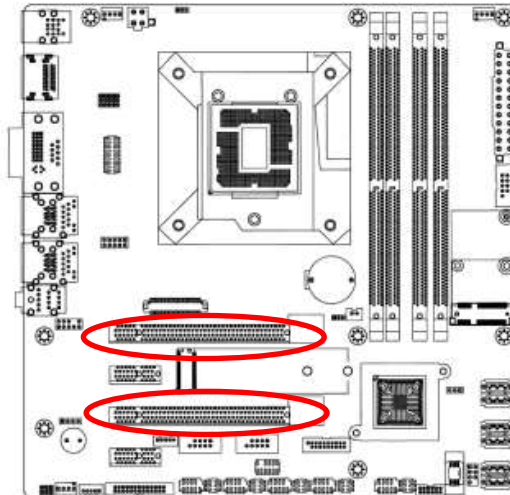

1.5.4 PCI Express x1 slot

This motherboard supports one PCIe x1 slot that complies with the PCIe x1 specifications.

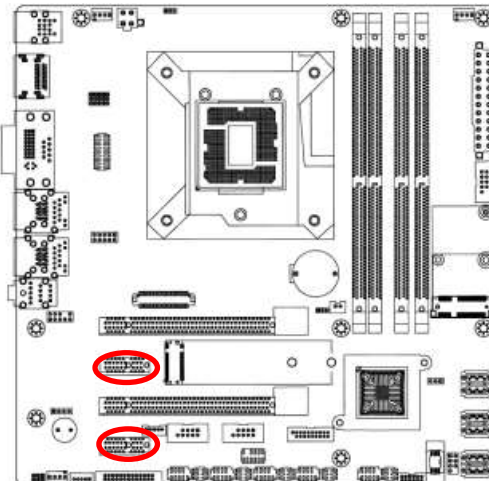

1.5.5 Mini PCIe connector

Support both Full size and half size mini-PCIe card

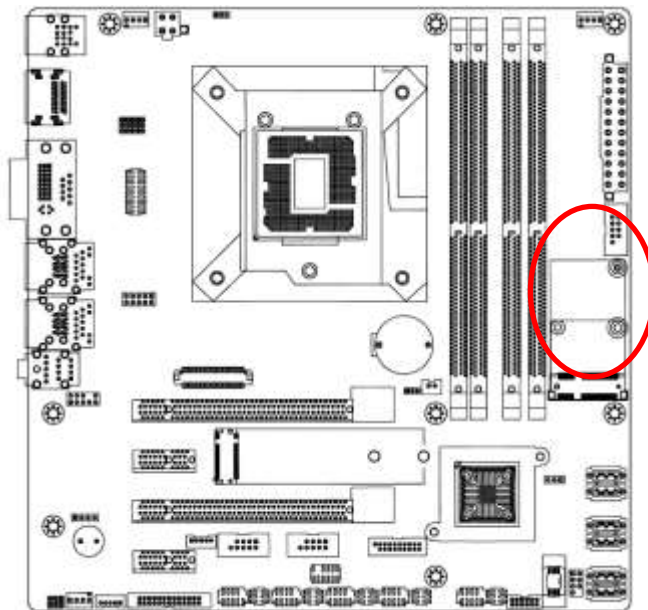

1.5.6 M.2 connector

Support PCIe and SATA interface of this connector.

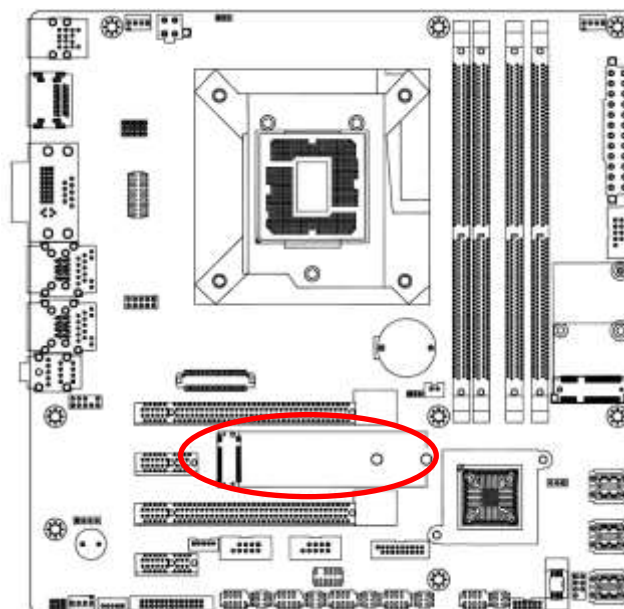

1.6 Jumpers

1.6.1 Clear CMOS (JCMOS1)

This jumper allows you to clear the Real Time Clock (RTC) RAM in CMOS. You can clear the CMOS memory of date, time, and system setup parameters by erasing the CMOS RTC RAM data. The onboard button cell battery powers the RAM data in CMOS, which includes system setup information such as system passwords.

To erase the RTC RAM:

1. Turn OFF the computer and unplug the power cord.
2. Remove the onboard battery.
3. Move the jumper cap from pins 1-2 (default) to pins 2-3. Keep the cap on pins 2-3 for about 5~10 seconds, and then move the cap back to pins 1-2.
4. Re-install the battery.
5. Plug the power cord and turn ON the computer.
6. Hold down the key during the boot process and enter BIOS setup to re-enter data.



Except when clearing the RTC RAM, never remove the cap on CLRTC jumper default position. Removing the cap will cause system boot failure!

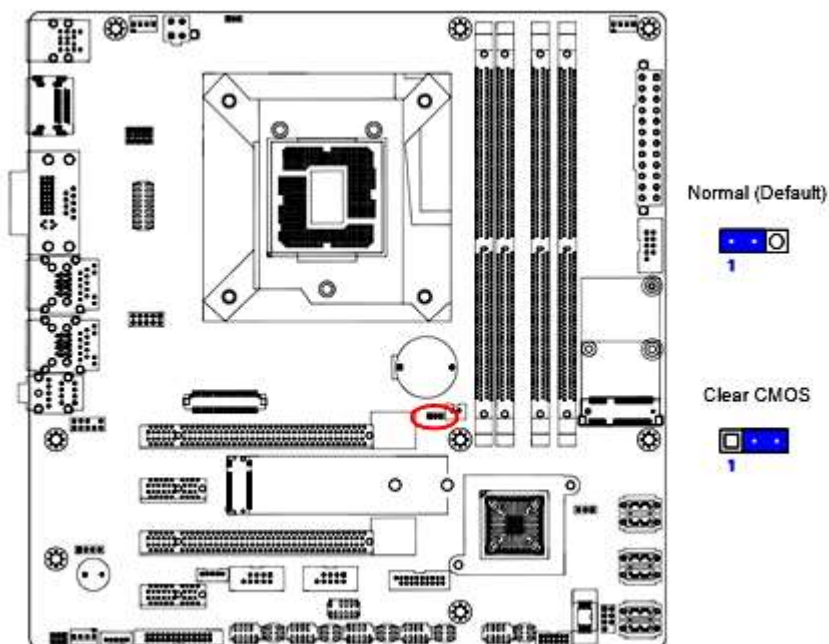

You do not need to clear the RTC when the system hangs due to overclocking. For system failure due to overclocking, use the C.P.R. (CPU Parameter Recall) feature. Shut down and reboot the system so the BIOS can automatically reset parameter settings to default values.

1.6.2 AT/ATX Power Mode Select (JPSON1)

This jumper allows you to select ATX Mode or AT mode

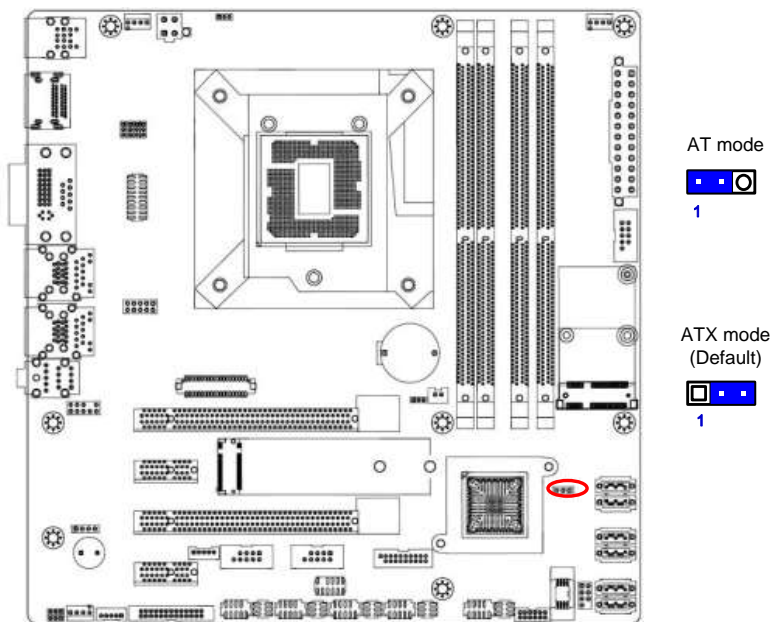

1.6.3 COM POWER SETTING (JCOMPWR1~5)

This jumper allows you to select COM2 to support Ring/+12V/+5V

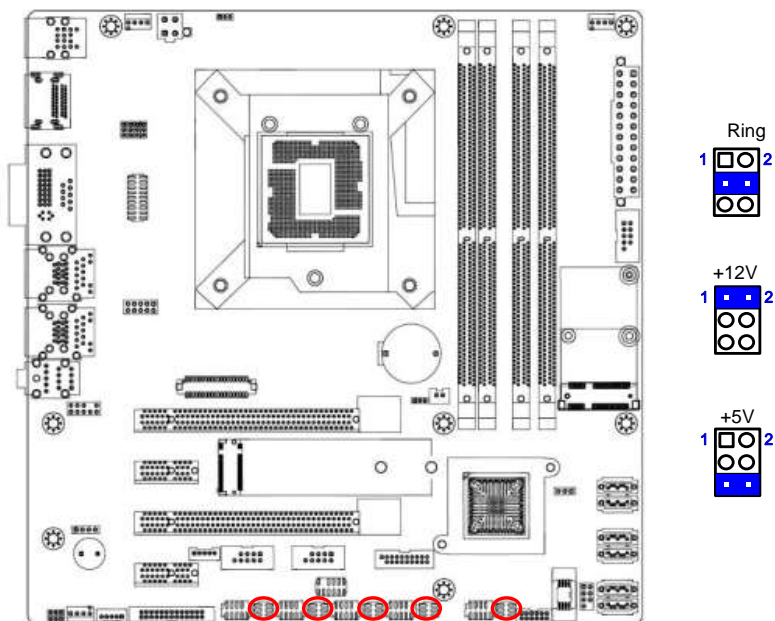

1.6.4 COM6 Master/Slave terminal Setting (COM6_S1~4)

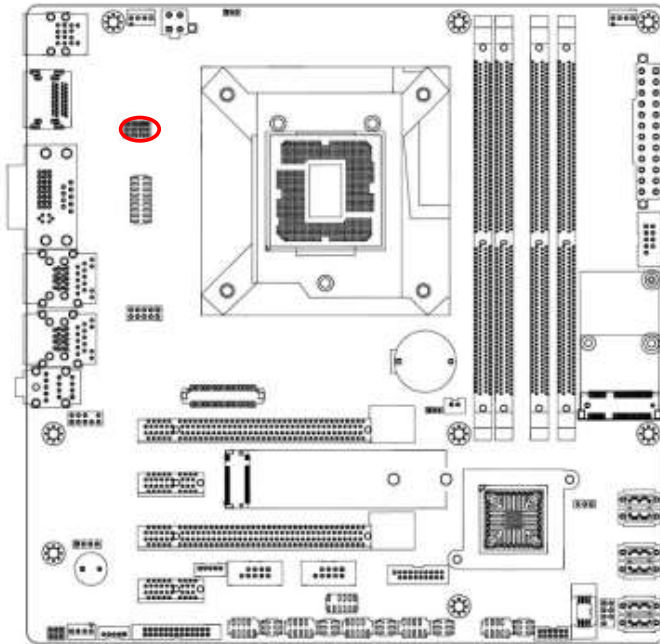

	S1	S2	S3	S4
RS-232	2-3	2-3	2-3	2-3
RS-485	1-2	1-2	2-3	2-3
RS-422	1-2	1-2	1-2	1-2

1.6.5 COM6 type Setting (JSETCOM6)

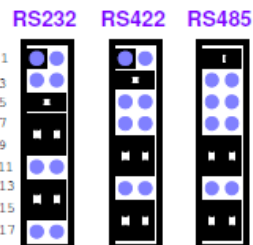
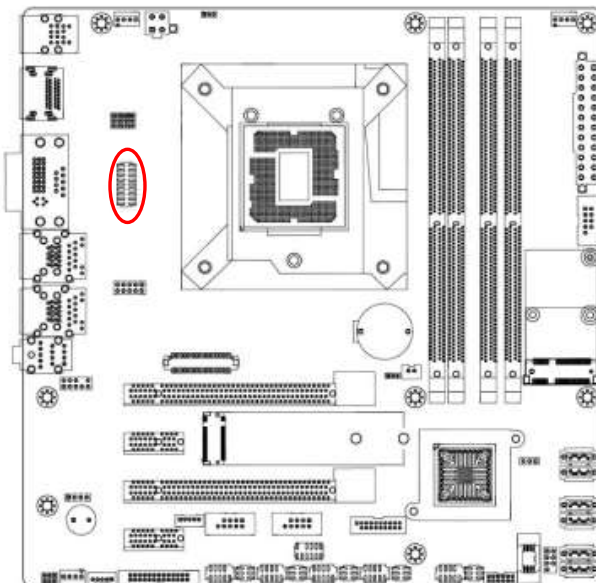

1.6.6 LVDS panel voltage Selection (JBKLVOL1)

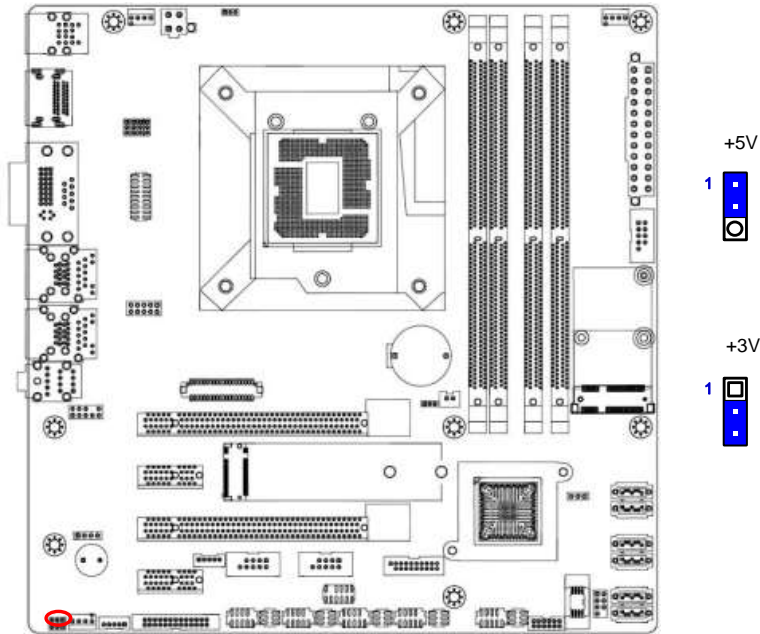

1.6.7 LVDS brightness control mode Selection (JLVDS_BKL1)

This jumper allows you to select the control mode of LVDS backlight.

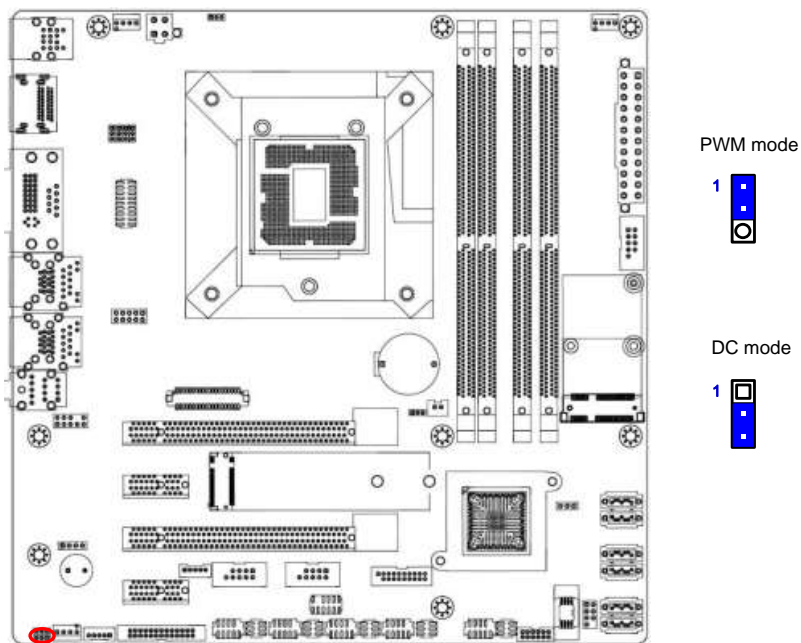

1.7 Connectors

1.7.1 Rear panel connectors

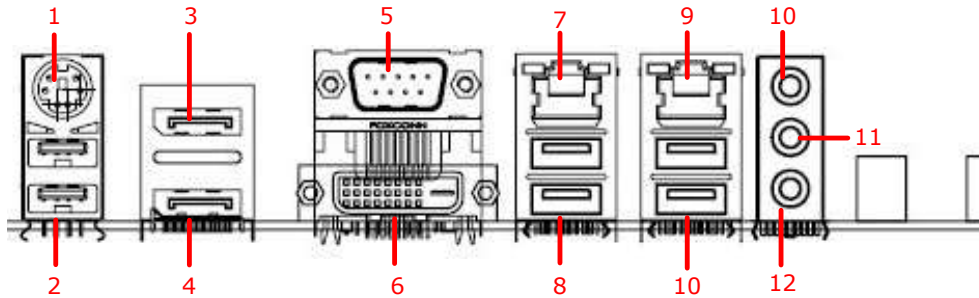

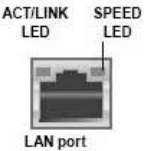
Item	Name	Function	Description																				
1	PS2	PS2 Connector	The connector is for PS2 Keyboard or Mouse																				
2	USB78	USB 2.0 Connectors	These two 2-pin Universal Serial Bus (USB) ports are available for connecting USB 2.0 devices.																				
3	DP1	Display Port	The display port Connector																				
4	DP2	Display Port	The display port Connector																				
5	COM1	Serial COM Port	The Serial COM port 1 supports RS-232/422/485																				
6	DVI1	DVI port	The DVI port Connector																				
7	LAN1	Gigabit LAN (RJ-45) Connectors	<p>This port allows Gigabit connection to a Local Area Network (LAN) through a network hub. Refer to the table below for the LAN port LED indications.</p> <div style="text-align: center;">  <p>ACT/LINK LED SPEED LED</p> <p>LAN port</p> </div> <table border="1" style="margin-left: auto; margin-right: auto;"> <thead> <tr> <th colspan="2">ACT/Link LED</th> <th colspan="2">Speed LED</th> </tr> <tr> <th>Status</th> <th>Description</th> <th>Status</th> <th>Description</th> </tr> </thead> <tbody> <tr> <td>OFF</td> <td>No link</td> <td>OFF</td> <td>10Mbps connection</td> </tr> <tr> <td>Orange</td> <td>Linked</td> <td>Green</td> <td>100Mbps connection</td> </tr> <tr> <td>Blinking</td> <td>Data activity</td> <td>Orange</td> <td>1Gbps connection</td> </tr> </tbody> </table>	ACT/Link LED		Speed LED		Status	Description	Status	Description	OFF	No link	OFF	10Mbps connection	Orange	Linked	Green	100Mbps connection	Blinking	Data activity	Orange	1Gbps connection
ACT/Link LED		Speed LED																					
Status	Description	Status	Description																				
OFF	No link	OFF	10Mbps connection																				
Orange	Linked	Green	100Mbps connection																				
Blinking	Data activity	Orange	1Gbps connection																				
8	USB12	USB 3.0 Connectors	These two 4-pin Universal Serial Bus (USB) ports are available for connecting USB 3.0 devices.																				

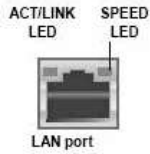
9	LAN2.	<p>Gigabit LAN (RJ-45) Connectors</p> 	<p>This port allows Gigabit connection to a Local Area Network (LAN) through a network hub. Refer to the table below for the LAN port LED indications.</p> <table border="1" data-bbox="651 392 1262 779"> <thead> <tr> <th colspan="2">ACT/Link LED</th> <th colspan="2">Speed LED</th> </tr> <tr> <th>Status</th> <th>Description</th> <th>Status</th> <th>Description</th> </tr> </thead> <tbody> <tr> <td>OFF</td> <td>No link</td> <td>OFF</td> <td>10Mbps connection</td> </tr> <tr> <td>Orange</td> <td>Linked</td> <td>Green</td> <td>100Mbps connection</td> </tr> <tr> <td>Blinking</td> <td>Data activity</td> <td>Orange</td> <td>1Gbps connection</td> </tr> </tbody> </table>	ACT/Link LED		Speed LED		Status	Description	Status	Description	OFF	No link	OFF	10Mbps connection	Orange	Linked	Green	100Mbps connection	Blinking	Data activity	Orange	1Gbps connection
ACT/Link LED		Speed LED																					
Status	Description	Status	Description																				
OFF	No link	OFF	10Mbps connection																				
Orange	Linked	Green	100Mbps connection																				
Blinking	Data activity	Orange	1Gbps connection																				
10	USB34	USB 3.0 Connectors	These two 4-pin Universal Serial Bus (USB) ports are available for connecting USB 3.0 devices.																				
11	AUDIO1	Line-in port (Light blue)	This port connects a tape, CD, DVD player, or other audio sources.																				
12	AUDIO1	Line-out port (Lime)	This port connects a headphone or a speaker. In 4-channel, 6-channel, and 8-channel configuration, the function of this port becomes Front Speaker Out.																				
13	AUDIO1	Microphone port (Pink)	This port connects a microphone.																				

1.7.2 CPU and System fan connectors (CPU_FAN1, SYS_FAN1, CHA_FAN1)

The fan connectors support cooling fans of 280mA (3.36 W max.) at 4800rpm or a total of 1A~2.22A (26.64W max.) at +12V. Connect the fan cables to the fan connectors on the motherboard, making sure that the black wire of each cable matches the ground pin of the connector.

RX170Q User's Manual

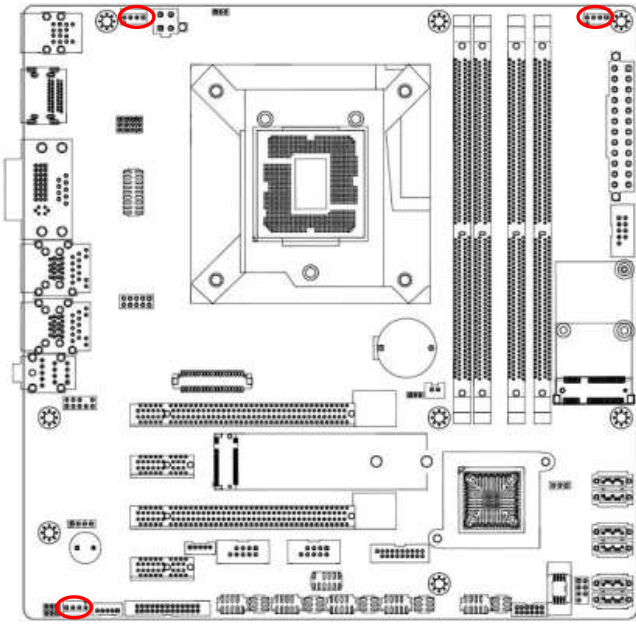

- CPU_FAN1**
- 4. FAN_PWM1
 - 3. FAN_SPEED2
 - 2. +V12
 - 1. GND
- SYS_FAN1**
- 4. FAN_PWM2
 - 3. FAN_SPEED2
 - 2. +V12
 - 1. GND
- CHA_FAN1**
- 4. CHA_PWM3
 - 3. FAN_SPEED3
 - 2. +V12
 - 1. GND



Do not forget to connect the fan cables to the fan connectors. Insufficient air flow inside the system may damage the motherboard components.

These are not jumpers! DO NOT place jumper caps on the fan connectors.

1.7.3 System Panel (F_PANEL)

This connector is for a chassis-mounted front panel. The functions are as following.

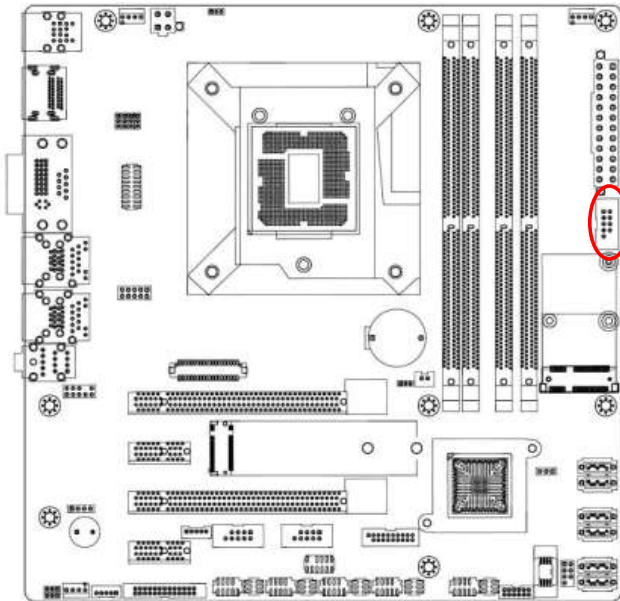

-
- 1. HDD LED+ 2. +5VSB
 - 3. HDD LED# 4. PWR LED#
 - 5. GND 6. PANSWIN#
 - 7. RST 8. GND
 - 9. N/A

- **ATX Power Button/Soft-off Button (Pin 6-8)**

This 2-pin connector is for the system power button. Pressing the power button turns the system on or puts the system in sleep or soft-off mode depending on the BIOS settings. Pressing the power switch and holding it for more than four seconds while the system is ON turns the system OFF.

- **Reset Button (Pin 5-7)**

This 2-pin connector is for the chassis-mounted reset button for system reboot without turning off the system power.

- **Power LED (Pin 2-4)**

This 2-pin connector is for the system power LED. Connect the chassis power LED cable to this connector. The system power LED lights up when you turn on the system power, and blinks when the system is in sleep mode.

- **Hard Disk Drive Activity LED (Pin 1-3)**

This 2-pin connector is for the HDD Activity LED. Connect the HDD Activity LED cable to this connector. The IDE LED lights up or flashes when data is read from or written to the HDD.

1.7.4 ATX power connectors (EATXPWR1 & ATX12V1)

The connector is for ATX power supply plugs. The power supply plugs are designed to fit these connectors in only one orientation. Find the proper orientation and push down firmly until the connectors completely fit.

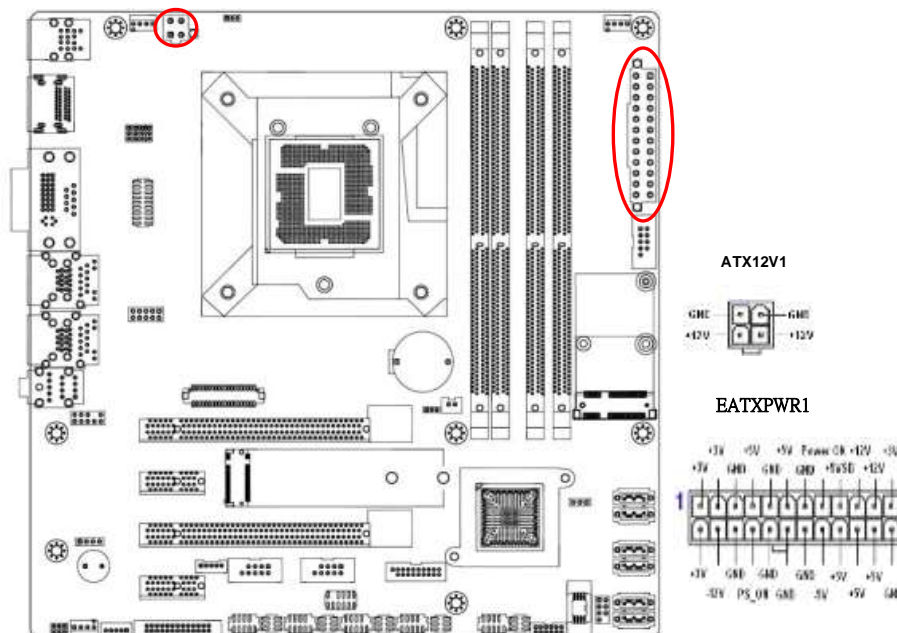

- Use of a PSU with a higher power output is recommended when configuring a system with more power-consuming devices. The system may become unstable or may not boot up if the power is inadequate.



RX170Q User's Manual

- Make sure that your power supply unit (PSU) can provide at least the minimum power required by your system. See the table below for details.

1.7.5 Serial Port connectors (COM1~5)

This connector is for a serial (COM) port. Connect the serial port module cable to this connector, and then install the module to a slot opening at the back of the system chassis.

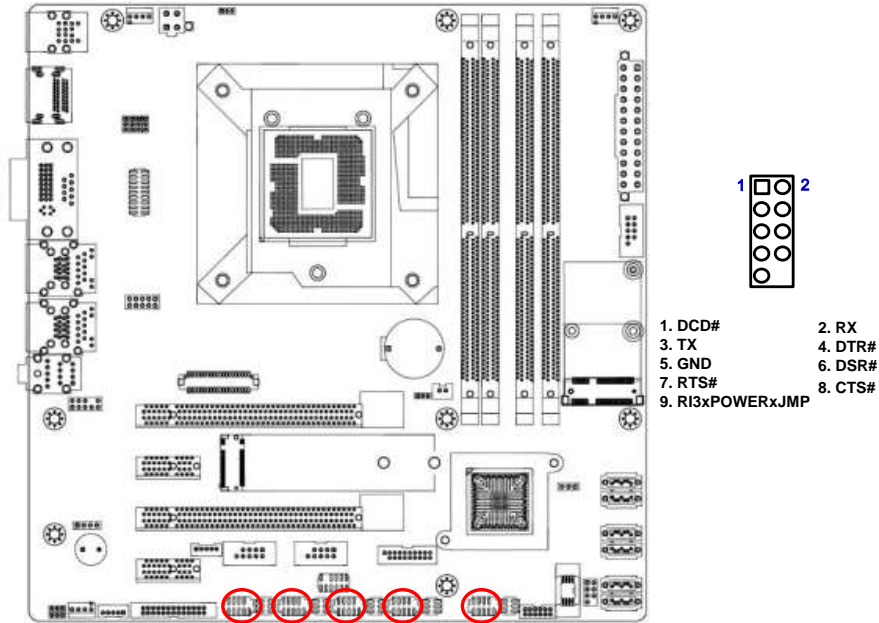

1.7.6 Serial ATA Connector (SATA1~6)

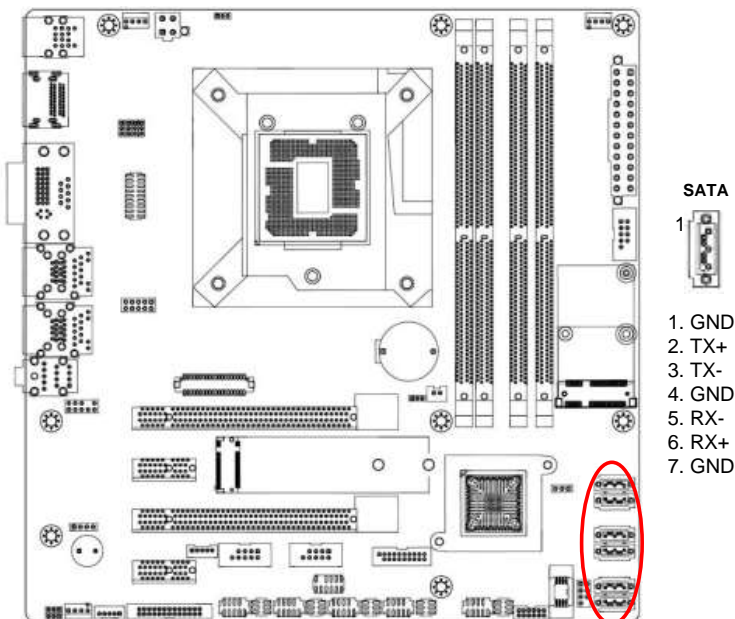

SATA 1~6 support SATA 3.0, and SATA 6 is shared by M.2 slot. These connectors are for the Serial ATA signal cables for Serial ATA hard disk drives.

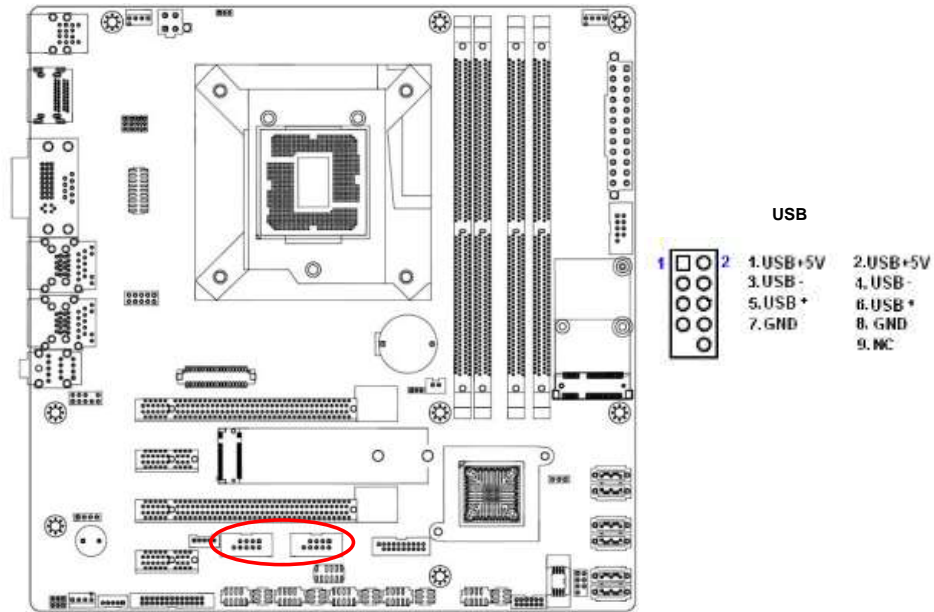

1.7.7 USB connectors (USB910, USB1112)

These connectors are for USB 2.0 ports. Connect the optional USB module cable to any of these connectors, and then install the module to a slot opening at the back of the system chassis. These USB connectors comply with USB 2.0 specification that supports up to 480 Mbps connection speed.



	<p>Never connect a 1394 cable to the USB connectors. Doing so will damage the motherboard!</p>
	<p>The USB module is purchased separately.</p>

1.7.8 USB connectors (USB13)

These connectors are for one USB 2.0 ports. Connect the optional USB module cable to any of these connectors, and then install the module to a slot opening at the back of the system chassis. These USB connectors comply with USB 2.0 specification that supports up to 480 Mbps connection speed.

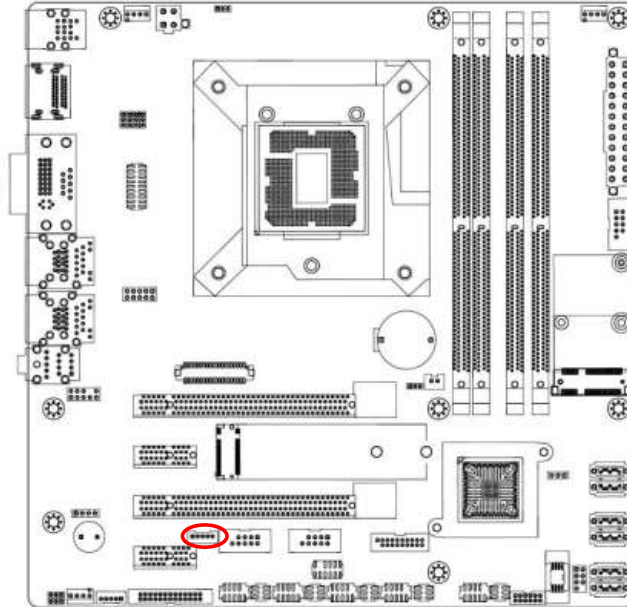

- 1
-
- 1.+5VUSB
 - 2. USB-
 - 3. USB+
 - 4. GND
 - 5. NC

1.7.9 USB3.0 connector (USB56)

This connector provides 2 USB3.0 port. Connect the optional USB module cable to any of these connectors, and then install the module to a slot opening at the back of the system chassis. These USB connectors comply with USB 3.0 specification that supports up to 5Gbps connection speed.

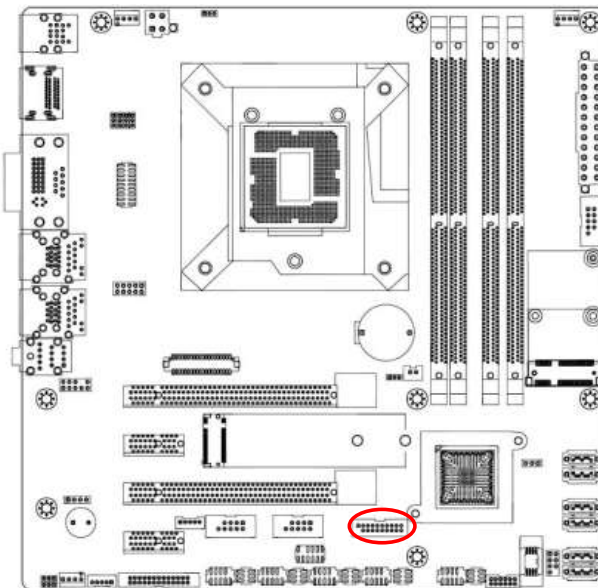

- USB56
-
- 1. +5V
 - 2. USB3_RX-
 - 3. USB3_RX+
 - 4. GND
 - 5. USB3_TX-
 - 6. USB3_TX+
 - 7. GND
 - 8. USB-
 - 9. USB+
 - 10. NC
 - 11. USB+
 - 12. USB-
 - 13. GND
 - 14. USB3_TX+
 - 15. USB3_TX-
 - 16. GND
 - 17. USB3_RX+
 - 18. USB3_RX-
 - 19. +5V

1.7.10 LPT Port Connector (LPT)

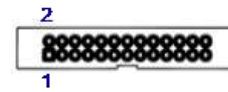
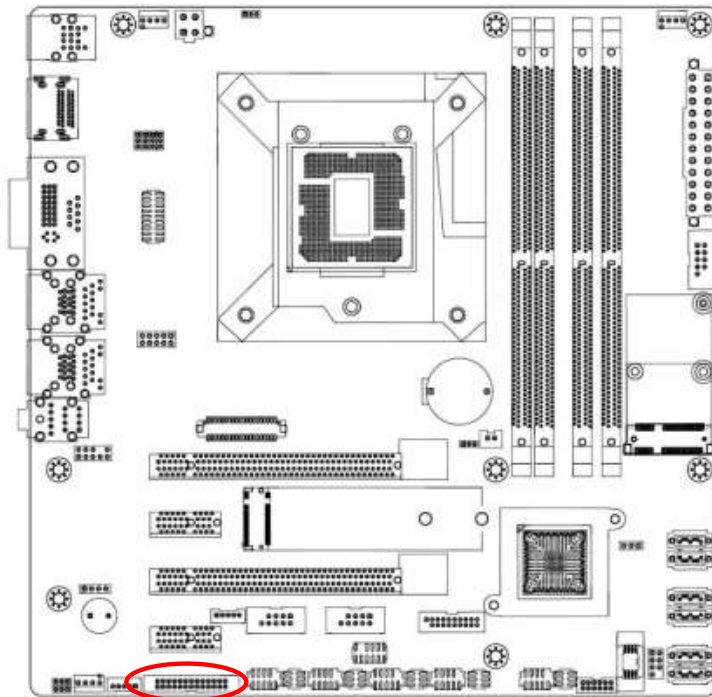

- 1. LPT_STB#
- 2. LPT_AFD#
- 3. LPT_PD0
- 4. LPT_ERR#
- 5. LPT_PD1
- 6. LPT_INIT#
- 7. LPT_PD2
- 8. LPT_SLIN#
- 9. LPT_PD3
- 10. GND
- 11. LPT_PD4
- 12. GND
- 13. LPT_PD5
- 14. GND
- 15. LPT_PD6
- 16. GND
- 17. LPT_PD7
- 18. GND
- 19. LPT_ACK#
- 20. GND
- 21. LPT_BUSY
- 22. GND
- 23. LPT_PE
- 24. GND
- 25. LPT_SLCT
- 26. NC

1.7.11 LAN LED status connector (LANLED1)

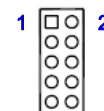
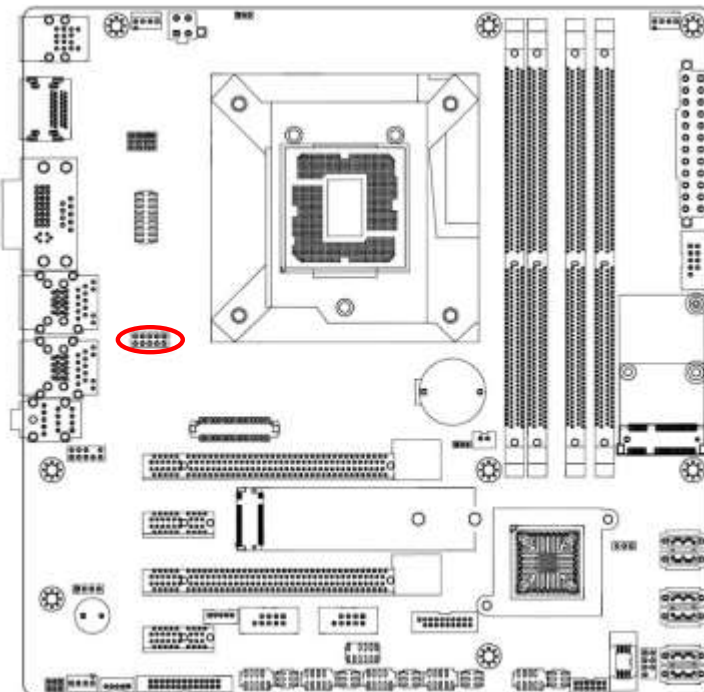

- 1. LAN1 100-LED +
- 2. LAN2 100-LED +
- 3. LAN1_speed-LED -
- 4. LAN2_speed LED -
- 5. LAN1_1000-LED +
- 6. LAN2_1000-LED +
- 7. LAN1_ACTLED -
- 8. LAN2_ACTLED -
- 9. LAN1_ACTLED +
- 10. LAN2_ACTLED +

1.7.12 8 bit GPIO header (JDIO1)

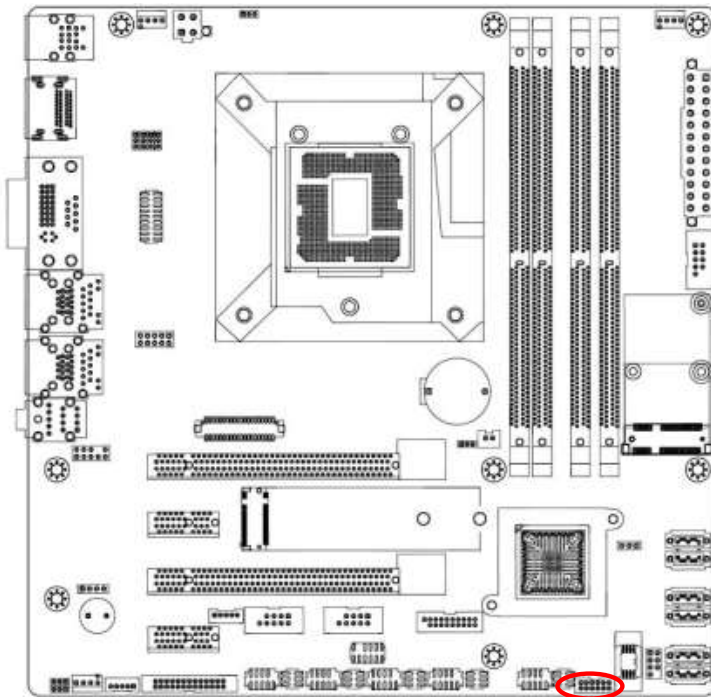

- | | |
|--------------|---------------|
| 1. SIO_GPIO0 | 2. SIO_GPIO4 |
| 3. SIO_GPIO1 | 4. SIO_GPIO5 |
| 5. SIO_GPIO2 | 6. SIO_GPIO6 |
| 7. SIO_GPIO3 | 8. SIO_GPIO7 |
| 9. SMB_CLK_ | 10. SMB_DATA_ |
| RESUME | RESUME |
| 11. GND | 12. +5Vsb |

1.7.13 Front Audio connector (FP_AUDIO1)

This connector is for a chassis-mounted front panel audio I/O module that supports either HD Audio or legacy AC '97 (optional) audio standard.

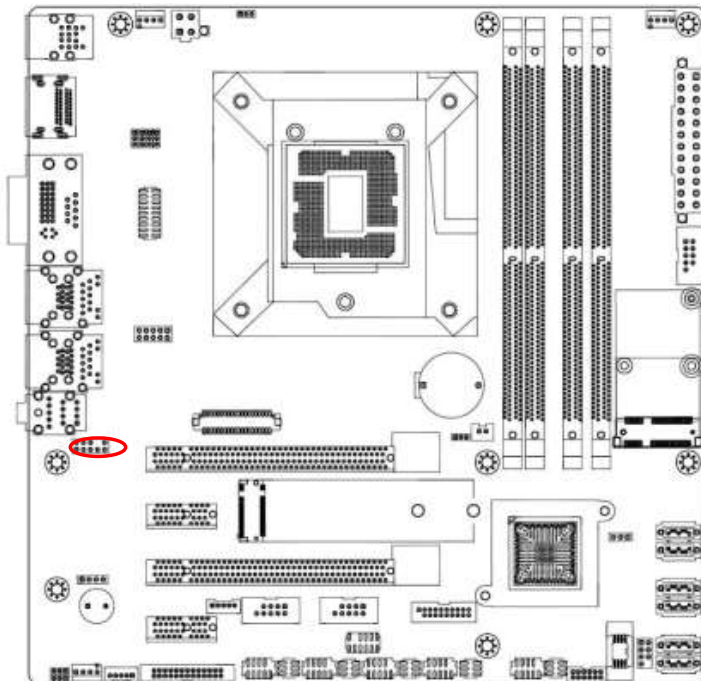

FP_AUDIO1



- | | |
|--------------|-----------|
| 10. LINE2-JD | 9. LINE2L |
| 8. NC | 7. SENSEB |
| 6. MIC2-JD | 5. LINE2R |
| 4. +3.3 | 3. MIC2R |
| 2. GND | 1. MIC2L |

1.7.14 Amplifier Connector (JAMP1)

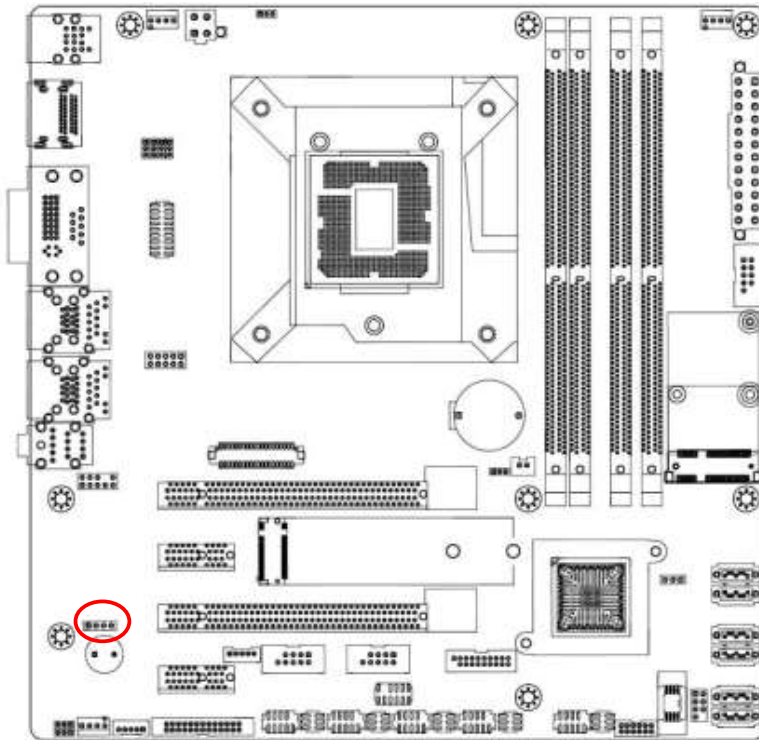

JAMP1

- 1 
- 1. AMP_L-
 - 2. AMP_L+
 - 3. AMP_R-
 - 4. AMP_R+

1.7.15 LVDS back light connector (JBKL1)

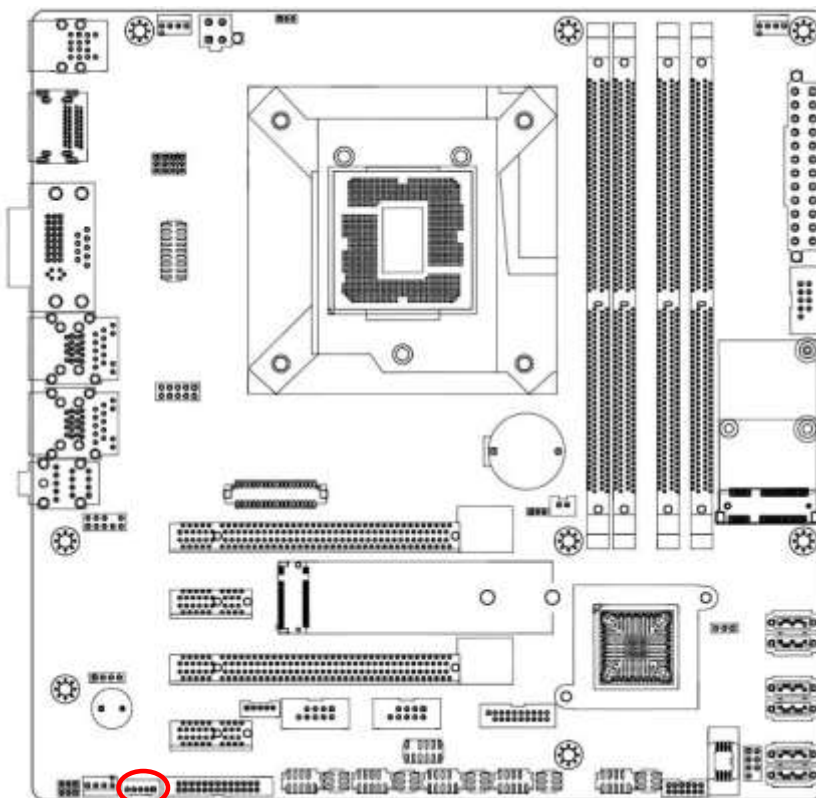

1 

- 1. +12V_BL
- 2. GND
- 3. BL_EN
- 4. BRIGHT1
- 5. +5V_BL

RX170Q User's Manual
1.7.16 LVDS connector (CN3)

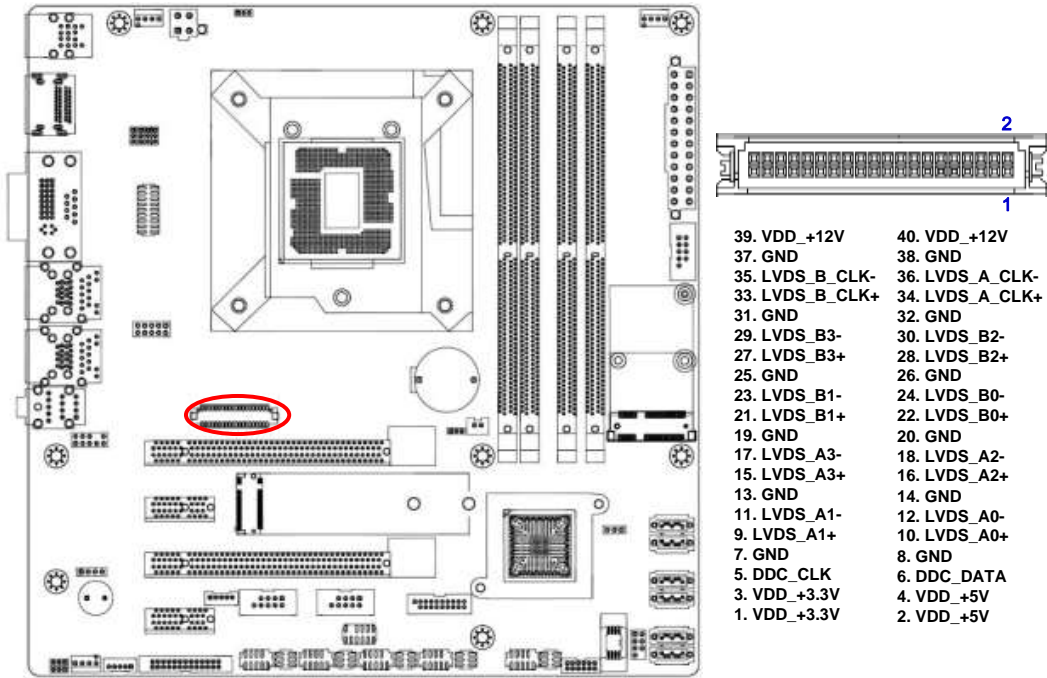

1.7.17 SM bus connector (JSMB1)

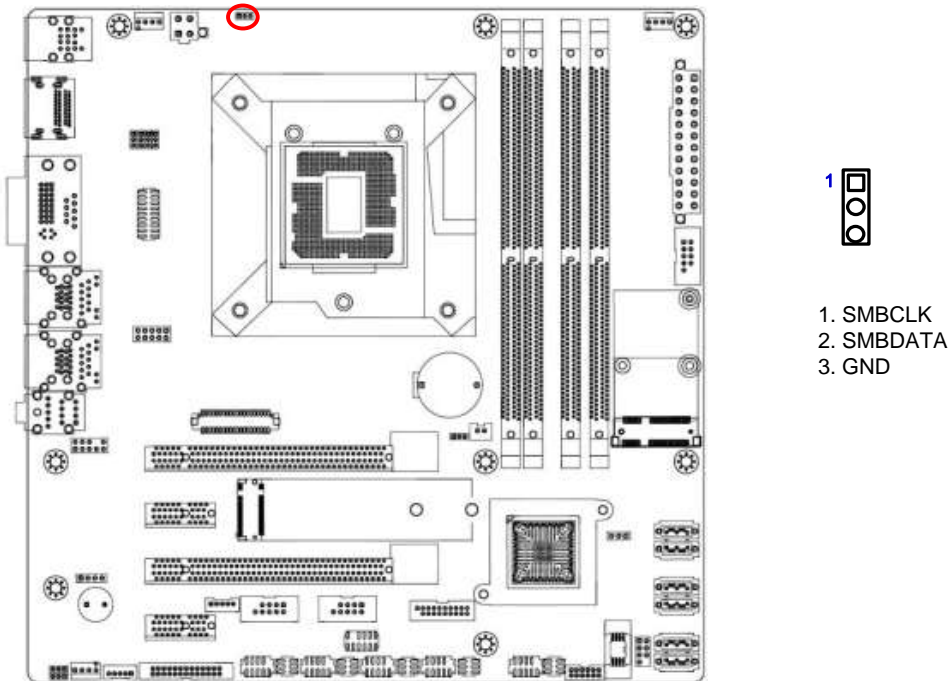

JSBB1 is reserve for factory manufacturing use only

This chapter tells how to change the system settings through the BIOS Setup menus. Detailed descriptions of the BIOS parameters are also provided.

2

BIOS Step

Chapter 2 - BIOS Setup

2.1 BIOS Setup Program

This motherboard supports a programmable firmware chip that you can update using the provided utility. Use the BIOS Setup program when you are installing a motherboard, reconfiguring your system, or prompted to “Run Setup.” This section explains how to configure your system using this utility.

Even if you are not prompted to use the Setup program, you can change the configuration of your computer in the future. For example, you can enable the security password feature or change the power management settings. This requires you to reconfigure your system using the BIOS Setup program so that the computer can recognize these changes and record them in the CMOS RAM of the firmware hub.

The firmware hub on the motherboard stores the Setup utility. When you start up the computer, the system provides you with the opportunity to run this program. Press during the Power-On-Self-Test (POST) to enter the Setup utility; otherwise, POST continues with its test routines.

If you wish to enter Setup after POST, restart the system by pressing <Ctrl+Alt+Delete>, or by pressing the reset button on the system chassis. You can also restart by turning the system off and then back on. Do this last option only if the first two failed.

The Setup program is designed to make it as easy to use as possible. Being a menu-driven program, it lets you scroll through the various sub-menus and make your selections from the available options using the navigation keys.



- The default BIOS settings for this motherboard apply for most conditions to ensure optimum performance. If the system becomes unstable after changing any BIOS settings, load the default settings to ensure system compatibility and stability. Select the **Load Optimized Defaults** from the BIOS menu screen.
- The BIOS setup screens shown in this section are for reference purposes only, and may not exactly match what you see on your screen.
- Visit the system builder's website to download the latest BIOS file for this motherboard

2.1.1 Legend Box

The keys in the legend bar allow you to navigate through the various setup menus

Key(s)	Function Description
→←	Select Screen
↑↓	Select Item
Enter	Select
+ -	Change Opt.
F1	General Help
F2	Previous Values
F3	Optimal Defaults
F4	Save and Exit
ESC	Exit

2.1.2 List Box

This box appears only in the opening screen. The box displays an initial list of configurable items in the menu you selected.

2.1.3 Sub-menu

Note that a right pointer symbol  appears to the left of certain fields. This pointer indicates that you can display a sub-menu from this field. A sub-menu contains additional options for a field parameter. To display a sub-menu, move the highlight to the field and press <Enter>. The sub-menu appears. Use the legend keys to enter values and move from field to field within a sub-menu as you would within a menu. Use the <Esc> key to return to the main menu.

Take some time to familiarize yourself with the legend keys and their corresponding functions. Practice navigating through the various menus and submenus. If you accidentally make unwanted changes to any of the fields, press <F3> to load the optimal default values. While moving around through the Setup program, note that explanations appear in the Item Specific Help window located to the right of each menu. This window displays the help text for the currently highlighted field.

2.2 BIOS Menu Screen

When you enter the BIOS, the following screen appears. The BIOS menu screen displays the items that allow you to make changes to the system configuration. To access the menu items, press the up/down/right/left arrow key on the keyboard until the desired item is highlighted, then press [Enter] to open the specific menu.

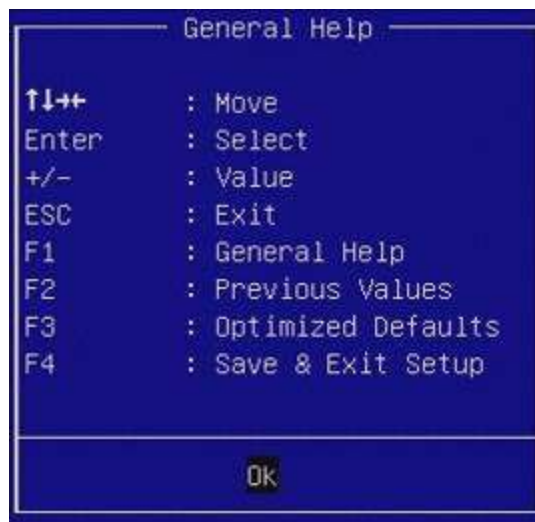

2.3 Main Setup

This menu gives you an overview of the general system specifications. The BIOS automatically detects the items in this menu. Use this menu for basic system configurations, such as time, date etc.

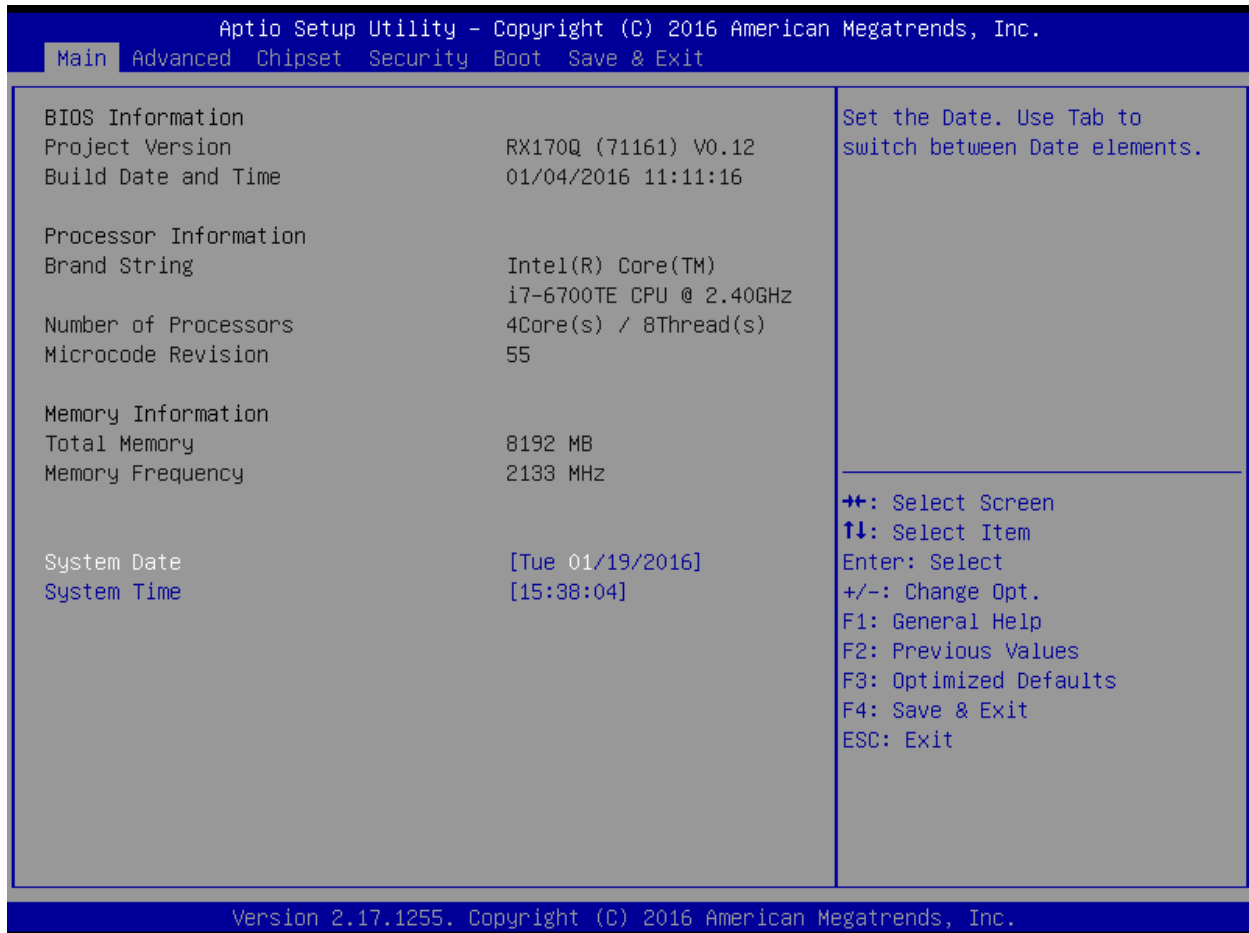

BIOS Information

Displays the auto-detected BIOS information.

- **System Date**

The date format is <Date>,<Month>,<Day>,<Year>.

- **System Time**

The time format is <Hour>,<Minute>,<Second>.

2.4 Advanced BIOS Setup

Select the Advanced tab from the setup screen to enter the Advanced BIOS Setup screen. You can select any of the items in the left frame of the screen, such as Chipset configuration, to go to the sub menu for that item. You can display an Advanced BIOS Setup option by highlighting it using the <Arrow> keys. All Advanced BIOS Setup options are described in this section. The Advanced BIOS Setup screen is shown below. The sub menus are described on the following pages.

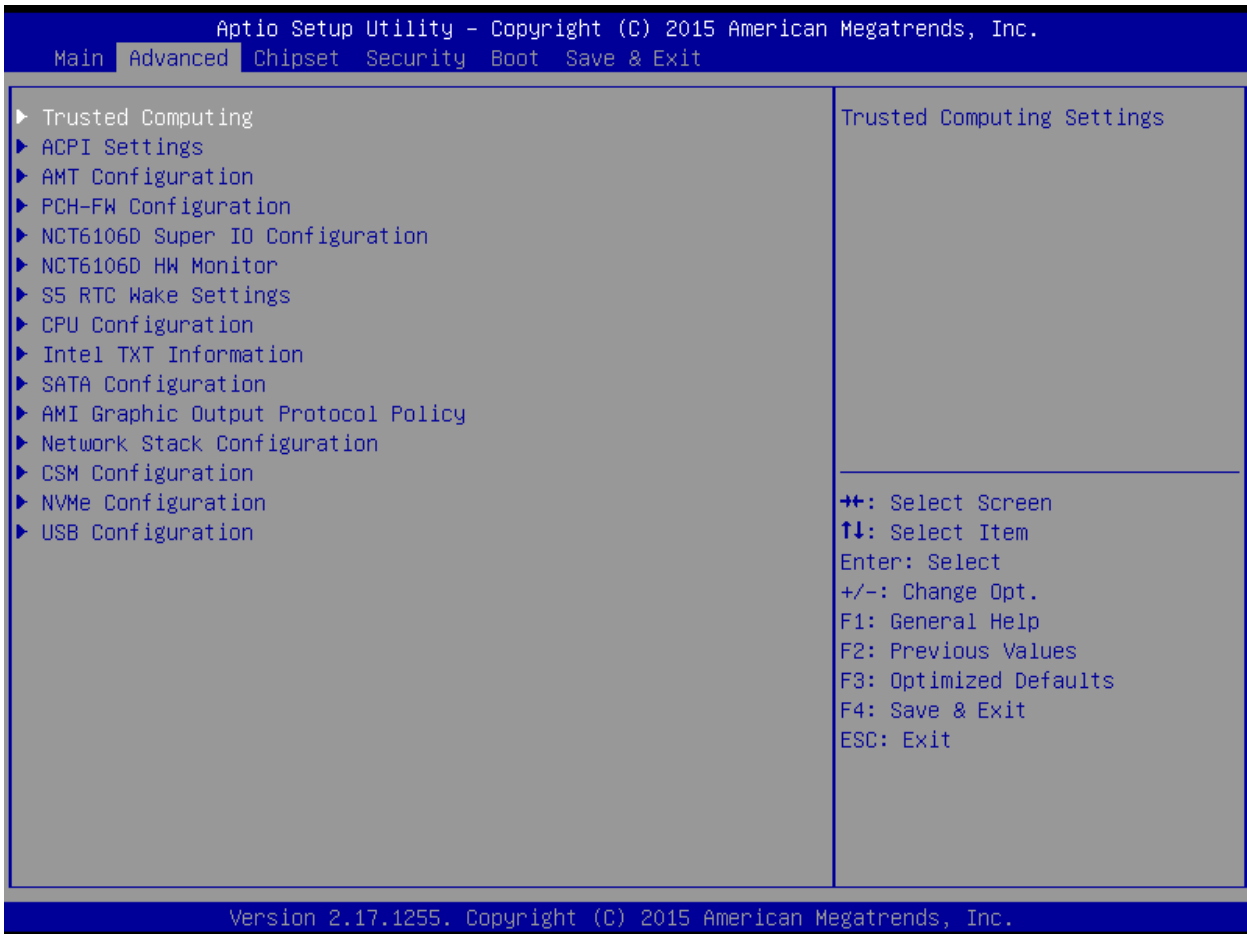

Take caution when changing the settings of the Advanced menu items. Incorrect field values can cause the system to malfunction.

2.4.1 Trusted Computing (optional)

Security device settings

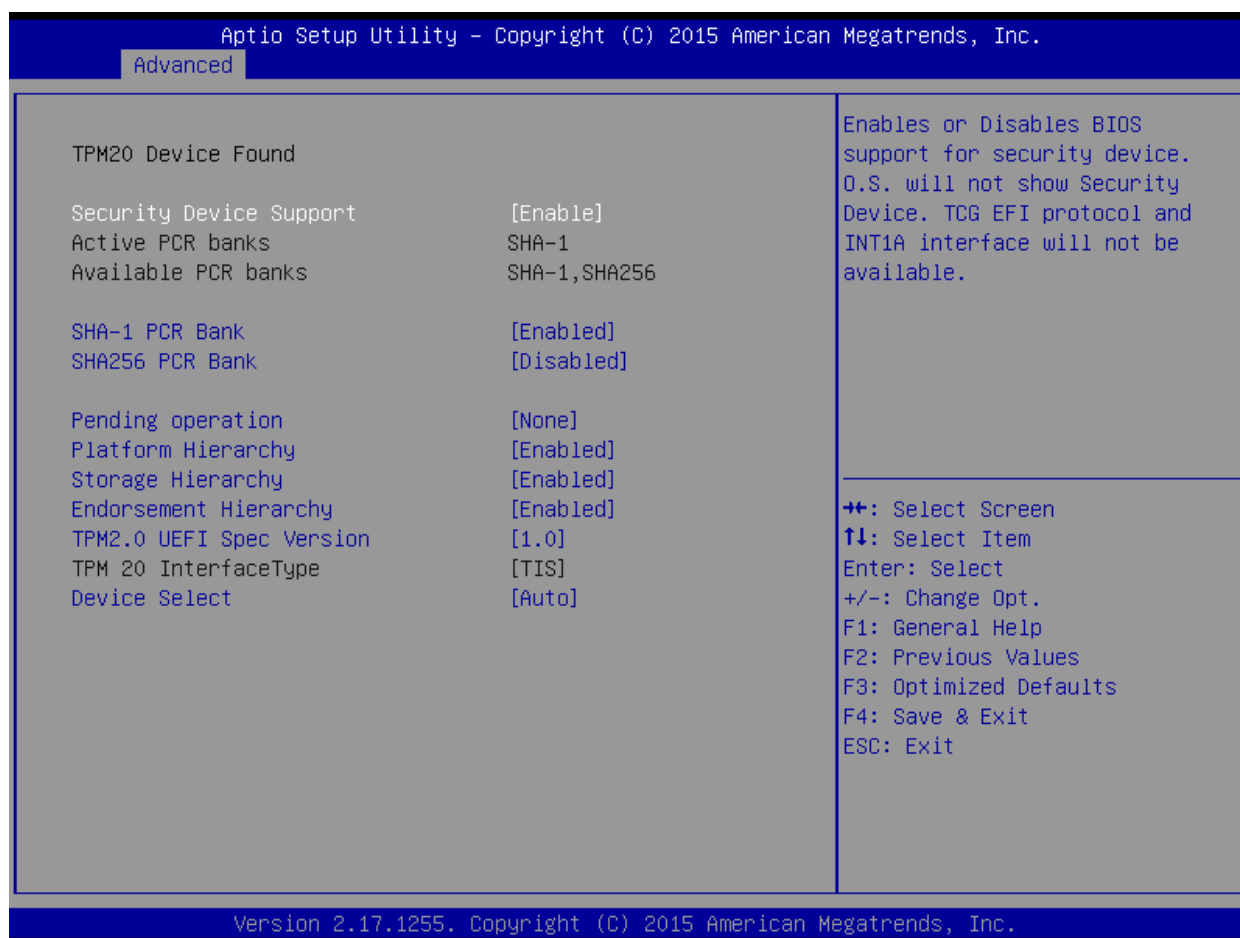

- **Security Device Support [Enable]**
Enable or Disable BIOS support for security device.
Configuration options: [Enable] [Disable]
- **SHA-1 PCR Bank [Enable]**
Enable or Disable SHA-1 PCR Bank.
Configuration options: [Enable] [Disable]
- **SHA256 PCR Bank [Disable]**
Enable or Disable SHA256 PCR Bank.
Configuration options: [Enable] [Disable]
- **Pending Operation [None]**
Schedule and operation for the Security Device.
Configuration options: [None] [TPM clear]
- **Platform Hierarchy [Enable]**
Enable or Disable Platform Hierarchy.
Configuration options: [Enable] [Disable]
- **Storage Hierarchy [Enable]**
Enable or Disable Storage Hierarchy.
Configuration options: [Enable] [Disable]

RX170Q User's Manual

- **Endorsement Hierarchy [Enable]**

Enable or Disable Endorsement Hierarchy.

Configuration options: [Enable] [Disable]

- **TPM2.0 UEFI Spec Version[1.0]**

Select TCG2 spec version: 1.0: the compatibility mode for Win8/Win10; 1.x: For TCG2 newer spec for Win10

Configuration options: [1.0] [1.x]

- **Device Select[Auto]**

Select TPM device version

Configuration options: [TPM1.2] [TPM1.0] [Auto]

2.4.2 ACPI Settings



- **Enable Hibernation [Enable]**

Enable or Disable system ability to Hibernation.

Configuration options: [Enable] [Disable]

- **ACPI Sleep State [S3 only (Suspend to RAM)]**

Select the highest ACPI sleep state the system will enter the SUSPEND button is press.

Configuration options: [Suspend Disable] [S3 only(suspend to RAM)]

- **S3 Video Repost [Disabled]**

Enable or disable S3 video repost

Configuration options: [Disabled] [Enabled]

- **PCIE# wake from S5 [Disabled]**

Enable or disable PCIE wake the system from S5.

Configuration options: [Disabled] [Enabled]

2.4.3 AMT configuration

AMT Configuration settings

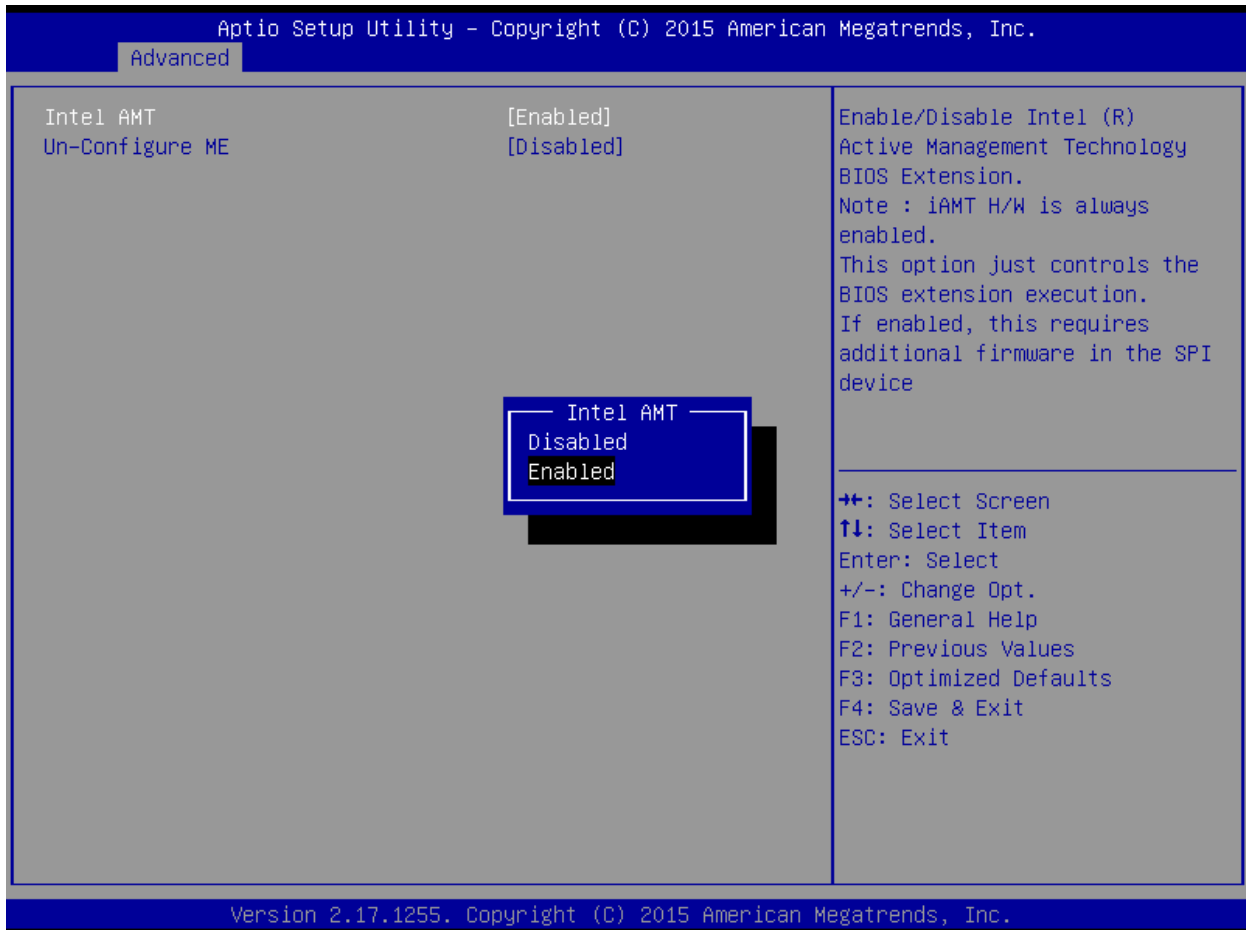

- **Intel AMT [Enable]**

Enable or Disable Intel AMT BIOS extension

Configuration options: [Disabled] [Enabled]

- **Un-Configure ME [Disable]**

Un-configure ME with Password

Configuration options: [Disabled] [Enabled]

RX170Q User's Manual

2.4.4 PCH-FW configuration

ME firmware information

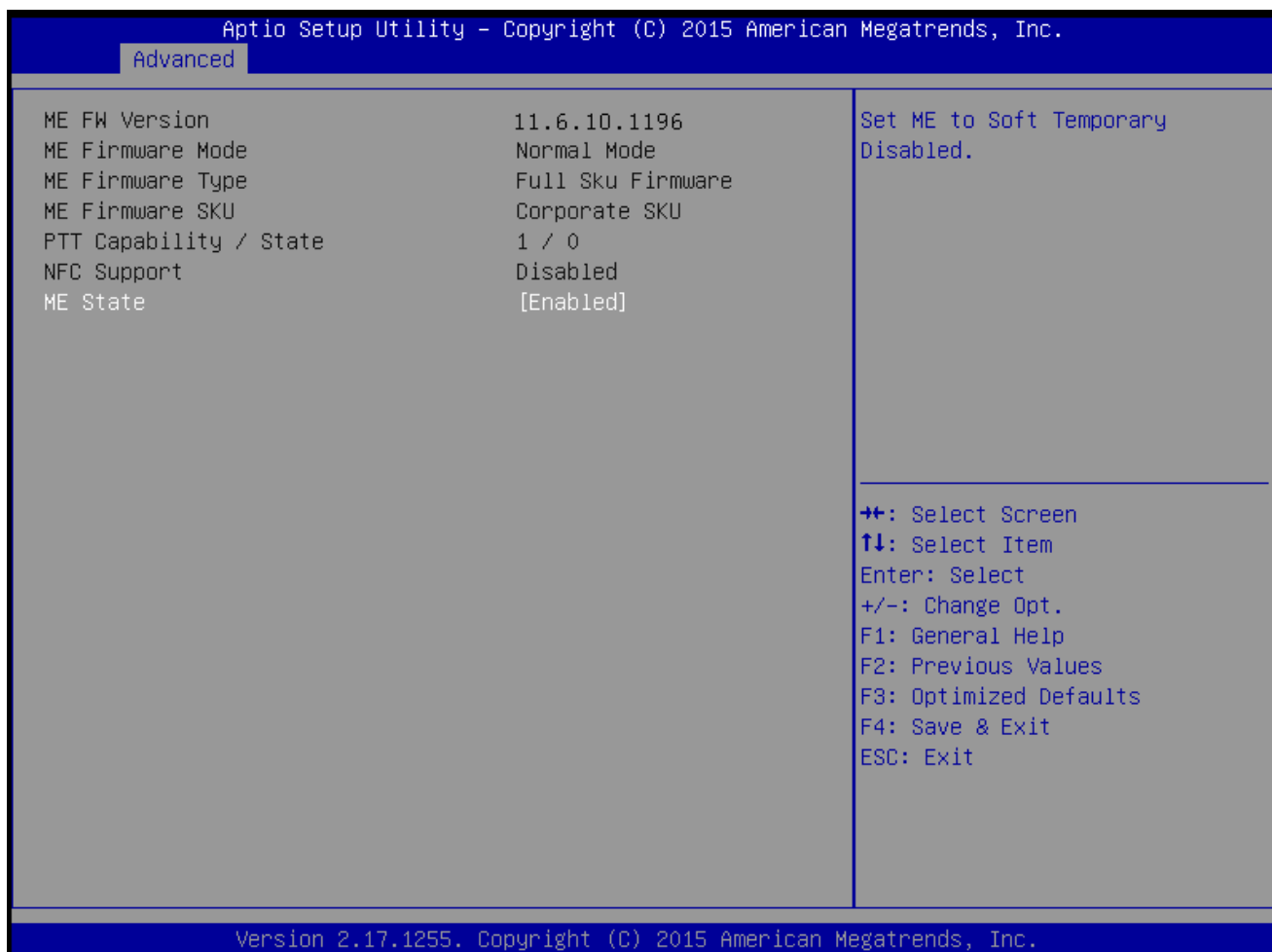

- **ME state [Enabled]**
Set ME to soft Temporary Disabled
Configuration options: [Disabled] [Enabled]

2.4.5 NCT6106D Super IO configuration

Provide NCT6106D super IO configuration settings

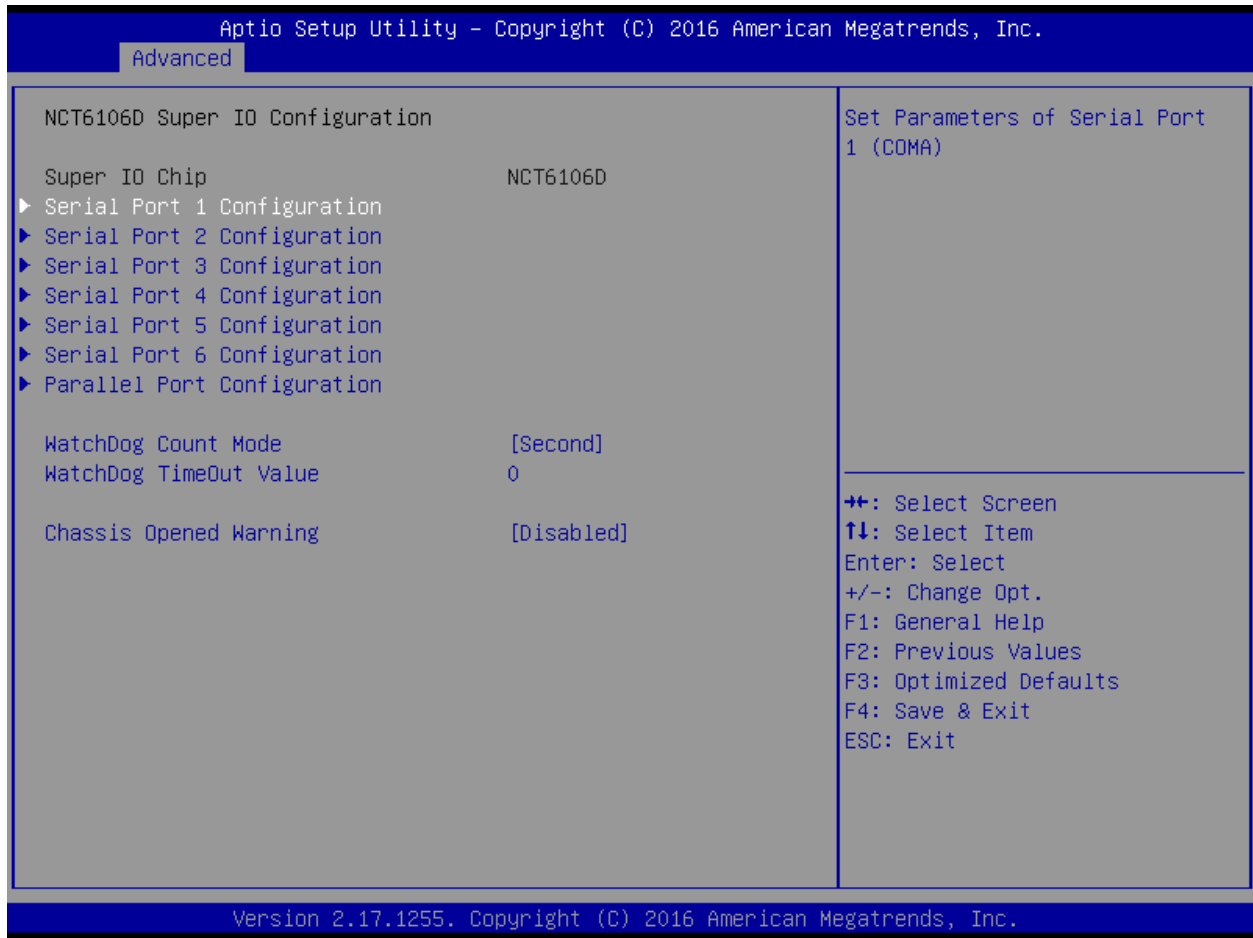

2.4.5.1 Serial Port 1 Configuration

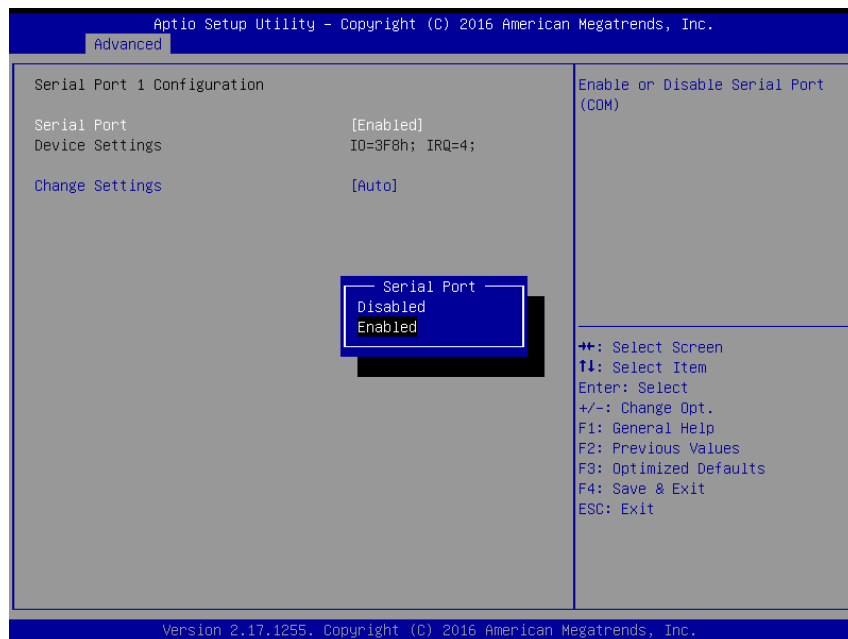

- **Serial Port [Enabled]**
Enable or Disable serial Port (COM)

RX170Q User's Manual

Configuration options: [Disabled] [Enabled]

- **Change Setting [Auto]**

Select an optimal setting for super IO device

Configuration options: as below

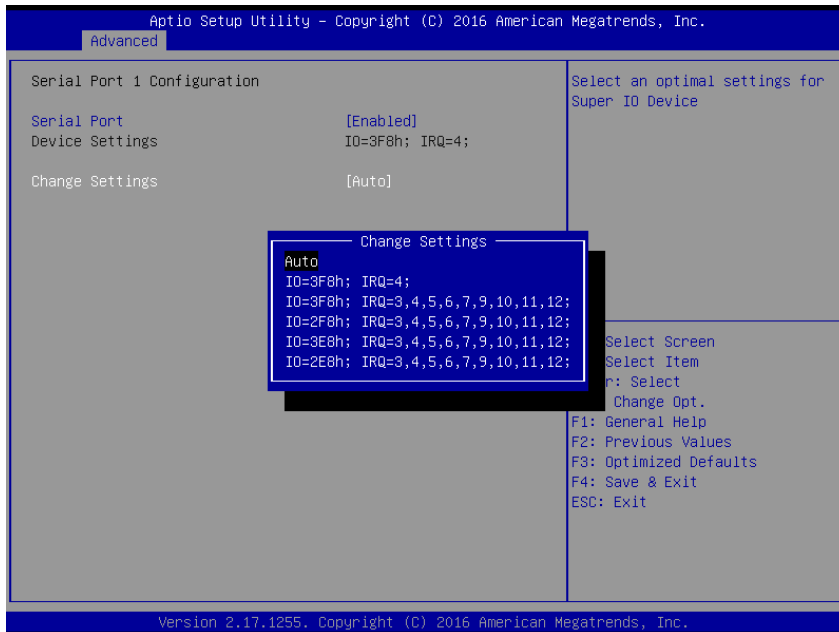

2.4.5.2 Serial Port 2 Configuration

- **Serial Port [Enabled]**

Enable or Disable serial Port (COM)

Configuration options: [Disabled] [Enabled]

- **Change Settings [Auto]**

Select an optimal setting for super IO device

Configuration options: as below

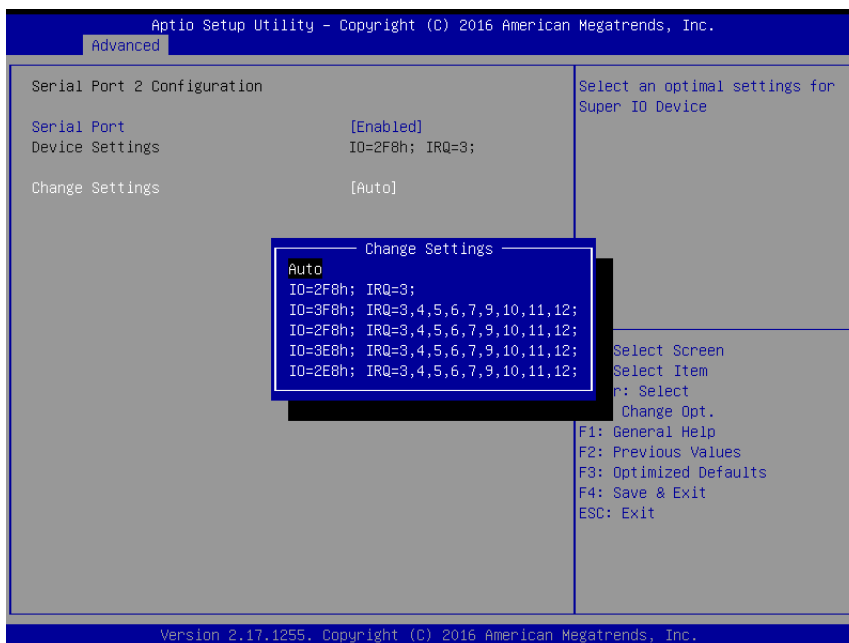

2.4.5.3 Serial Port 3 Configuration

- **Serial Port [Enabled]**
 Enable or Disable serial Port (COM)
 Configuration options: [Disabled] [Enabled]
- **Change Settings [Auto]**
 Select an optimal setting for super IO device
 Configuration options: as below

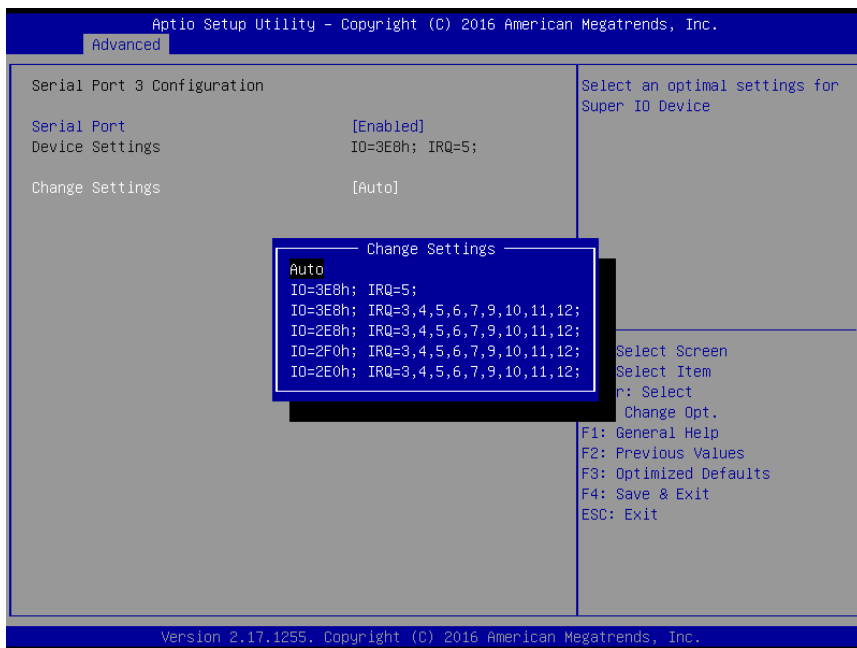

2.4.5.4 Serial Port 4 Configuration

- **Serial Port [Enabled]**
 Enable or Disable serial Port (COM)
 Configuration options: [Disabled] [Enabled]
- **Change Settings [Auto]**
 Select an optimal setting for super IO device
 Configuration options: as below

RX170Q User's Manual

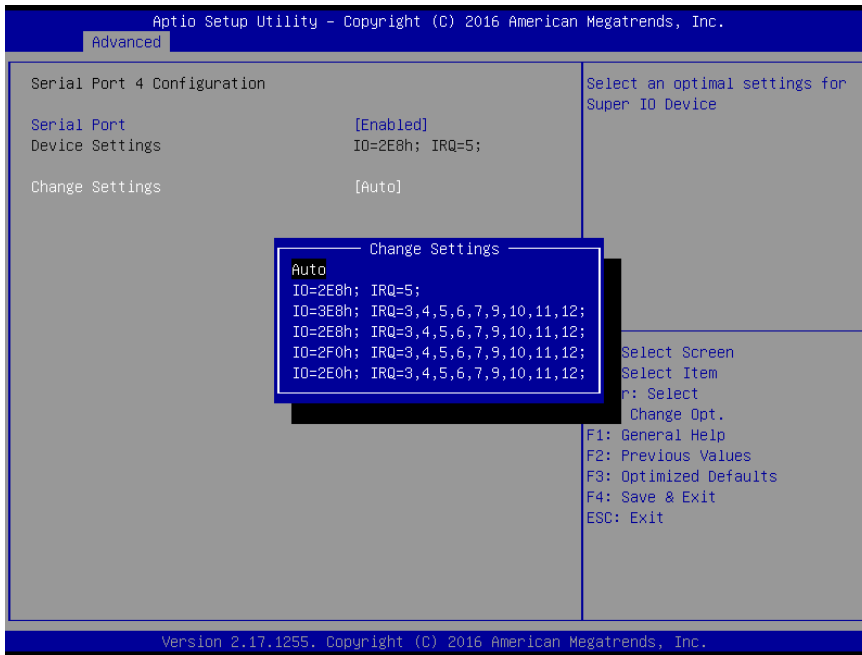

2.4.5.5 Serial Port 5 Configuration

- **Serial Port [Enabled]**
Enable or Disable serial Port (COM)
Configuration options: [Disabled] [Enabled]
- **Change Settings [Auto]**
Select an optimal setting for super IO device
Configuration options: as below

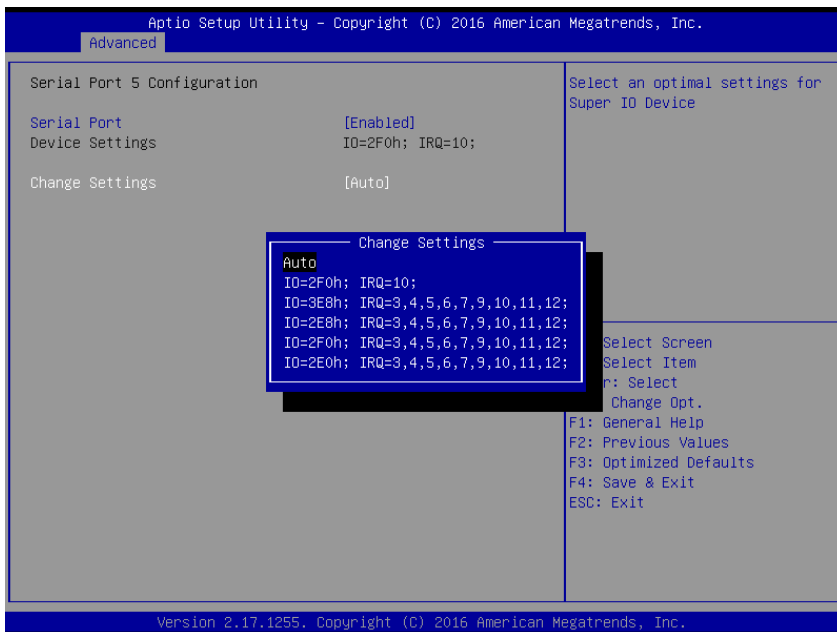

2.4.5.6 Serial Port 6 Configuration

- **Serial Port [Enabled]**
Enable or Disable serial Port (COM)

Configuration options: [Disabled] [Enabled]

- **Change Settings [Auto]**

Select an optimal setting for super IO device

Configuration options: as below

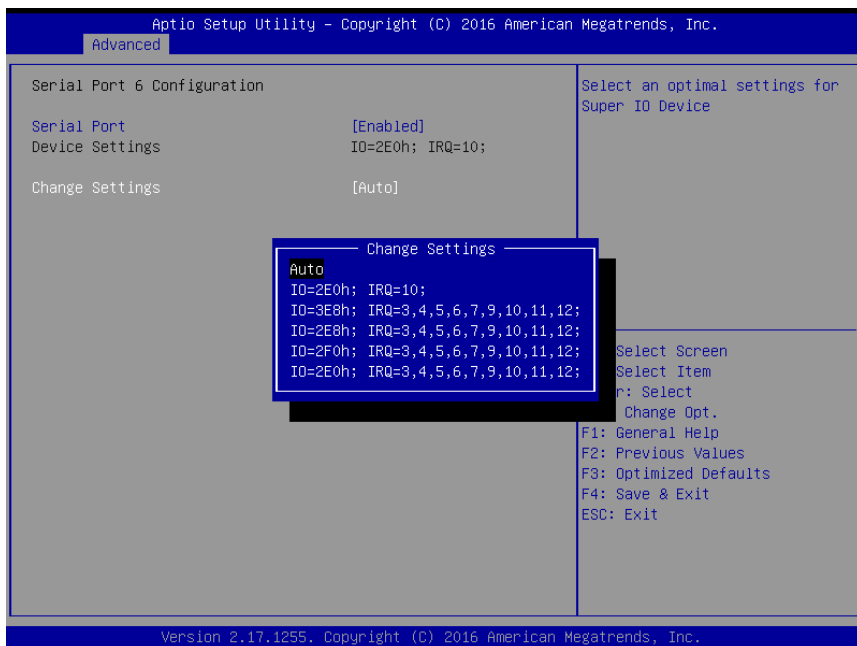

2.4.5.7 Parallel Port Configuration

- **Serial Port [Enabled]**

Enable or Disable parallel Port (LPT)

Configuration options: [Disabled] [Enabled]

- **Change Settings [Auto]**

Select an optimal setting for super IO device

Configuration options: as below

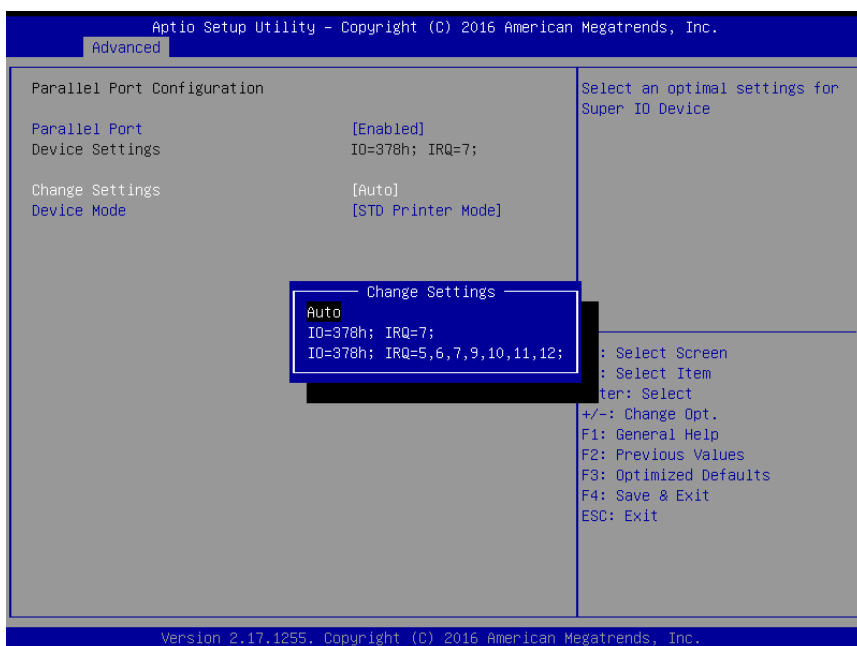

- **Device mode [STD Printer Mode]**

RX170Q User's Manual

Change the printer port mode

Configuration options: as below

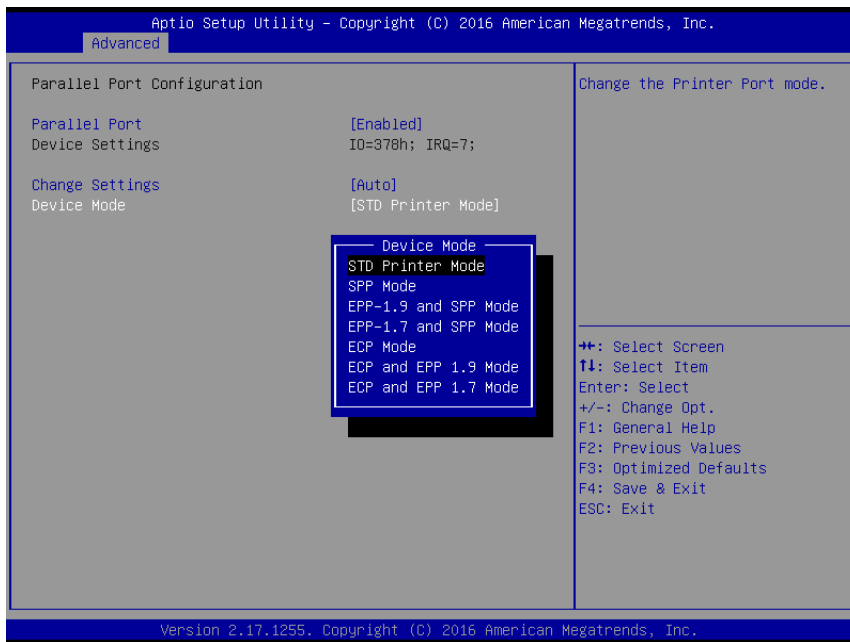

- **WatchDog count mode [Second]**
WatchDog count mode Selection
Configuration options: [Second] [Minute]
- **WatchDog Timeout value**
Fill watchdog timeout value, 0 means disables
- **Chassis opened warning [Disabled]**
Select chassis intrusion enabled to Disabled
Configuration options: [Disabled] [Enabled]

2.4.6 NCT6106D HW monitor

Display Hardware monitor information

Aptio Setup Utility - Copyright (C) 2015 American Megatrends, Inc.

Advanced

<p>Pc Health Status</p> <p>▶ Smart Fan</p> <p>System Temperature : +29 C</p> <p>CPU Temperature (PECI) : +25 C</p> <p>SYS_FAN1 Speed : N/A</p> <p>CPU_FAN1 Speed : 4017 RPM</p> <p>CHA_FAN1 Speed : N/A</p> <p>VCORE : +0.968 V</p> <p>+12V : +12.384 V</p> <p>+5V : +5.056 V</p> <p>5V_Dual : +4.782 V</p> <p>AVCC : +3.232 V</p> <p>3VSB : +3.216 V</p> <p>3VCC : +3.376 V</p> <p>VBAT : +3.104 V</p>	<p>Smart Fan Function Page</p> <hr/> <p>←←: Select Screen</p> <p>↑↓: Select Item</p> <p>Enter: Select</p> <p>+/-: Change Opt.</p> <p>F1: General Help</p> <p>F2: Previous Values</p> <p>F3: Optimized Defaults</p> <p>F4: Save & Exit</p> <p>ESC: Exit</p>
--	--

Version 2.17.1255. Copyright (C) 2015 American Megatrends, Inc.

2.4.6.1 Smart FAN

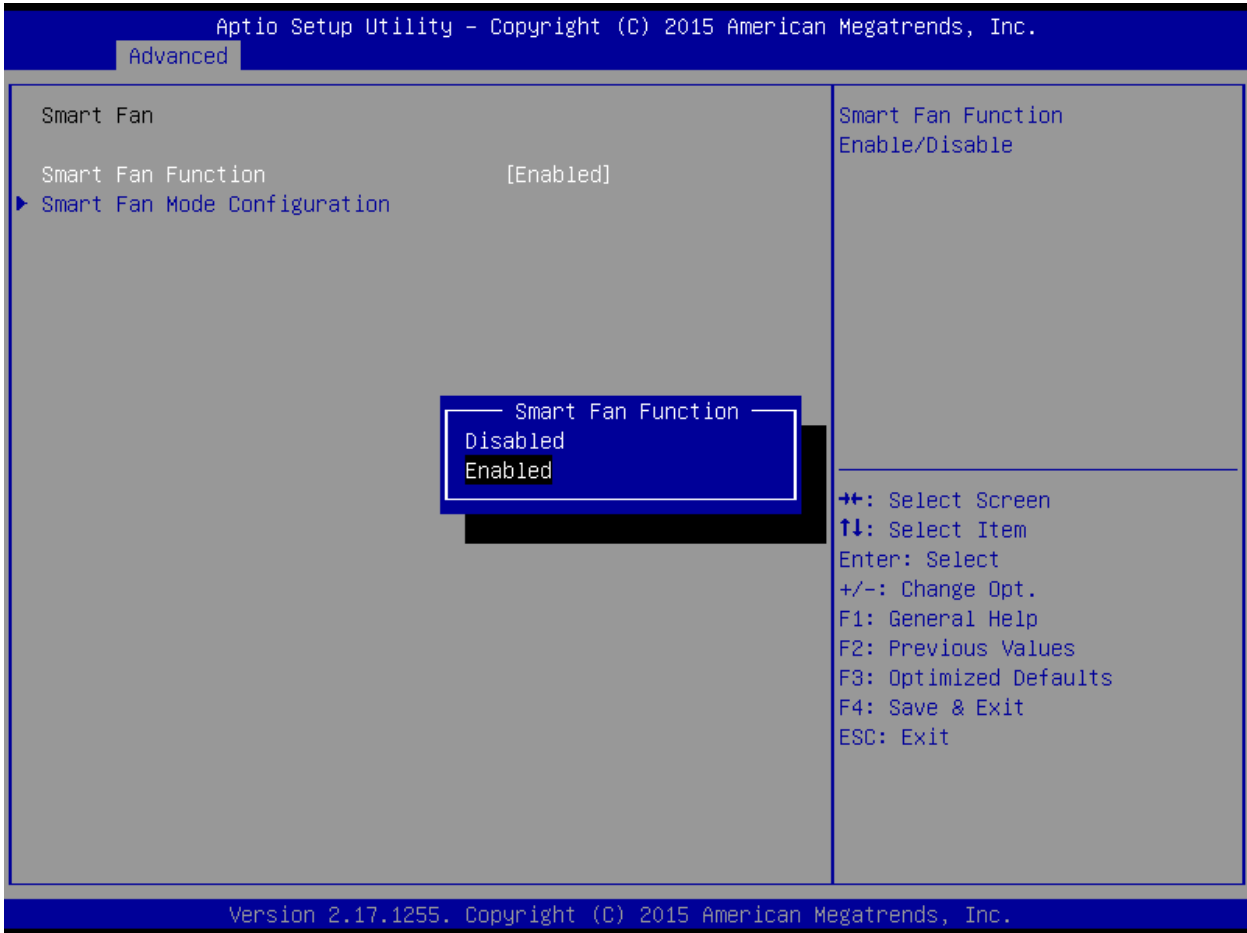

- **Smart FAN Function [Enabled]**
Smart fan function Enable/Disabled
Configuration options: [Enabled] [Disabled]

2.4.6.1.1 Smart FAN mode Configuration

Setting different FAN on this motherboard

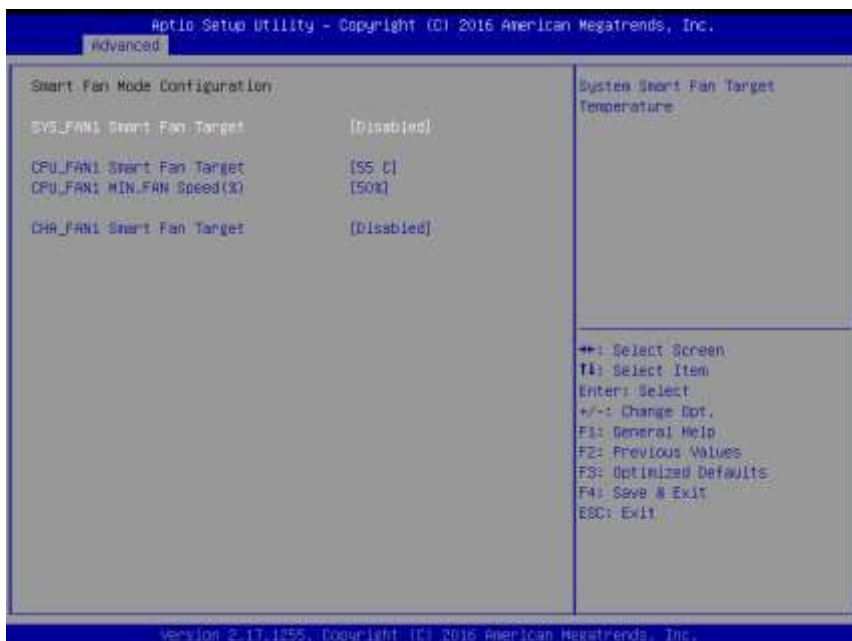

- SYS_FAN1/CPU_FAN1/CHA_FAN1 FAN Target [Disabled]**
 Smart FAN target temperature
 Configuration options: Please see below picture

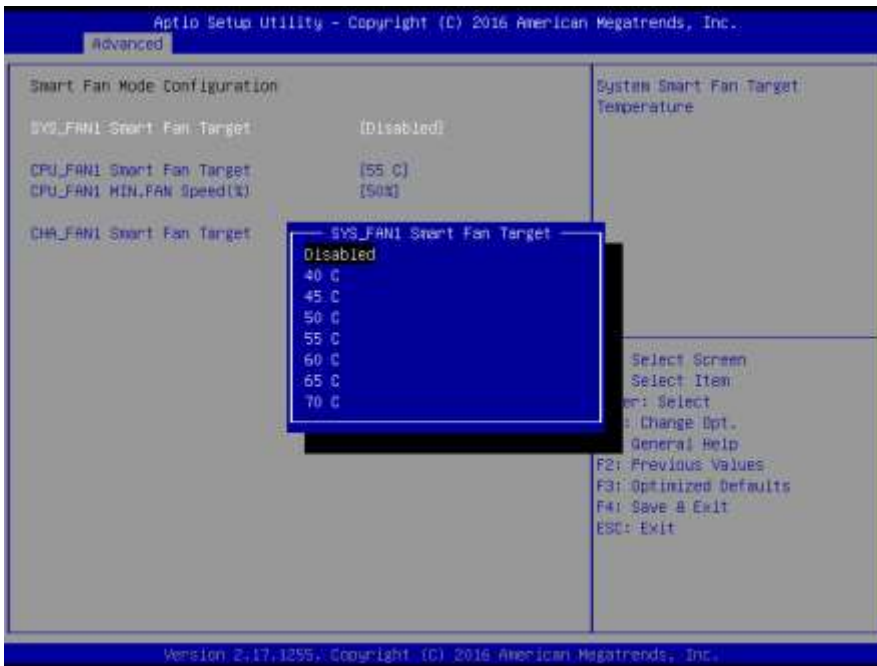

- CPU_FAN1 MIN.FAN Speed(%) [50%]**
 CPU Smart FAN minimum settings
 Configuration options: Please see below picture

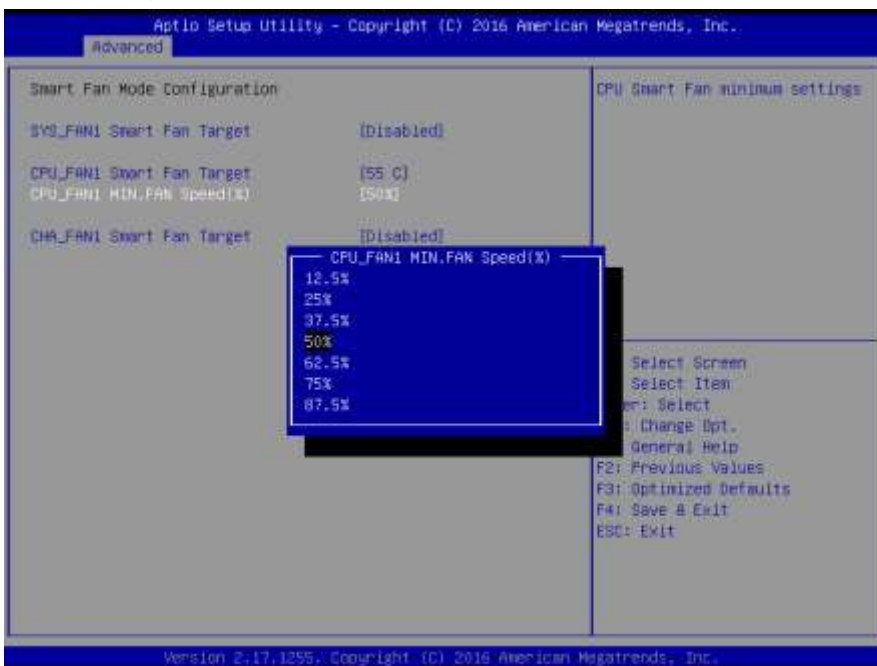

RX170Q User's Manual

2.4.7 S5 RTC wake settings

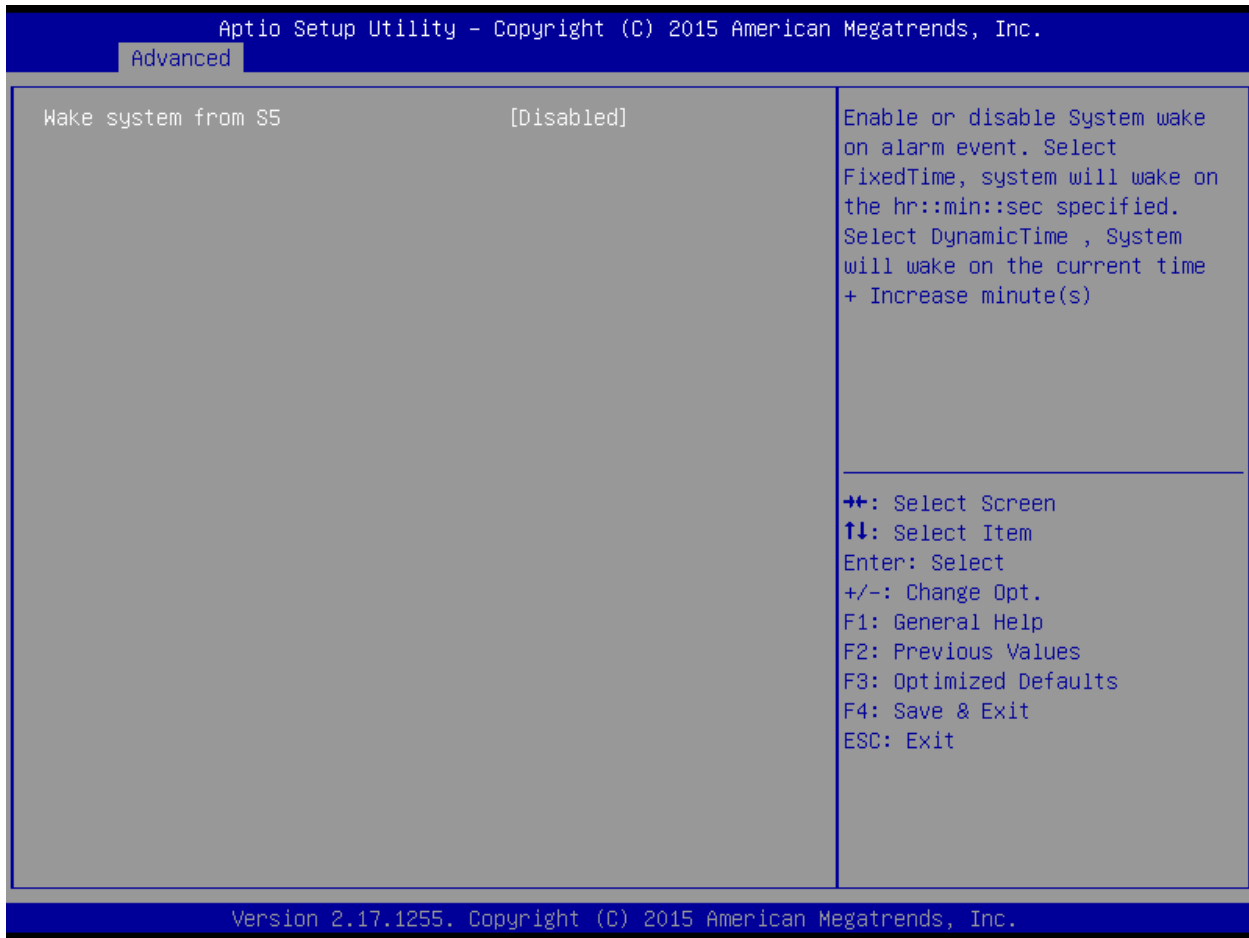

- **Wake system from S5 [Disabled]**
Enabled or Disabled system wake on alarm event
Configuration options: [Enabled] [Disabled]

2.4.8 CPU configuration

Display CPU configuration

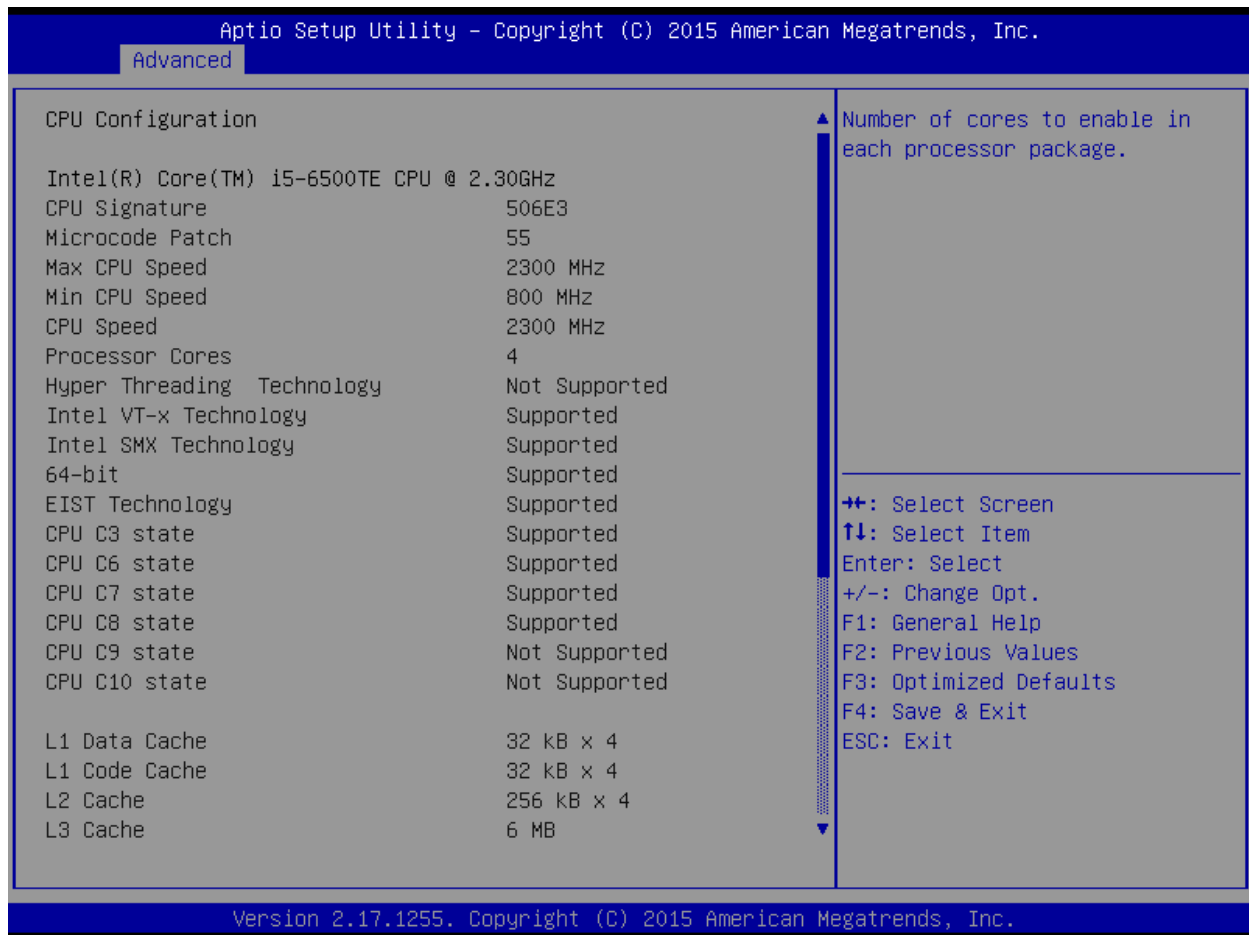

- **Hyper-Threading [Enabled]**

Enabled or Disabled the hyper threading of Intel CPU

Configuration options: [Disabled][Enabled]

This depends on CPU sku.

- **Active Processor Core [All]**

Number of Cores to enable in each processor package

Configuration options: [all] [1][2][3][4]

This depends on CPU sku.

- **Intel Virtualization Technology [Enabled]**

When enabled, a VMM can utilize the additional hardware capabilities provided by vanderpool Technology

Configuration options: [Disabled][Enabled]

- **Intel® SpeedStep™ [Enabled]**

Allow more than two frequency ranges to be supported.

Configuration options: [Disabled][Enabled]

- **Turbo mode [Enabled]**

Enable or disable Turbo mode

Configuration options: [Enabled] [Disabled]

RX170Q User's Manual

- **CPU C states [Enabled]**

Enable or disable CPU C states

Configuration options: [Enabled] [Disabled]

- **Enhanced C-states [Enabled]**

Enable or disable C1E. When enabled, CPU will switch to minimum speed when all cores enter C-state.

Configuration options: [Enabled] [Disabled]

- **Package C state limit [Auto]**

Package C state limit

Configuration options: [C0/C1][C2][C3][C6][C7][C7s][C8][Auto]

- **Intel TXT(LT) Support [Disabled]**

Enable or disable Intel TXT support

Configuration options: [Enabled] [Disabled]

- **SW Guard Extensions(SGX) [software controlled]**

Enable or disables Guard Extensions

Configuration options:[Disabled][Enabled][Software Controlled]

- **Select owner EPOCH input type [No change in owner EPOCHs]**

After user enters EPOCH values manually, the values will not be visible for security reasons

Configuration options:[No change in owner EPOCHs][change to new random owner EPOCHs][Manual user defined owner EPOCHs]

2.4.9 Intel TXT information

Display Intel TXT information

Aptio Setup Utility - Copyright (C) 2015 American Megatrends, Inc.

Advanced

Intel TXT Information	
Chipset	Production Fused
BiosAcm	Production Fused
Chipset Txt	Supported
Cpu Txt	Supported
Error Code	None
Class Code	None
Major Code	None
Minor Code	None

++: Select Screen
 ↑↓: Select Item
 Enter: Select
 +/-: Change Opt.
 F1: General Help
 F2: Previous Values
 F3: Optimized Defaults
 F4: Save & Exit
 ESC: Exit

Version 2.17.1255. Copyright (C) 2015 American Megatrends, Inc.

RX170Q User's Manual

2.4.10 SATA Configuration

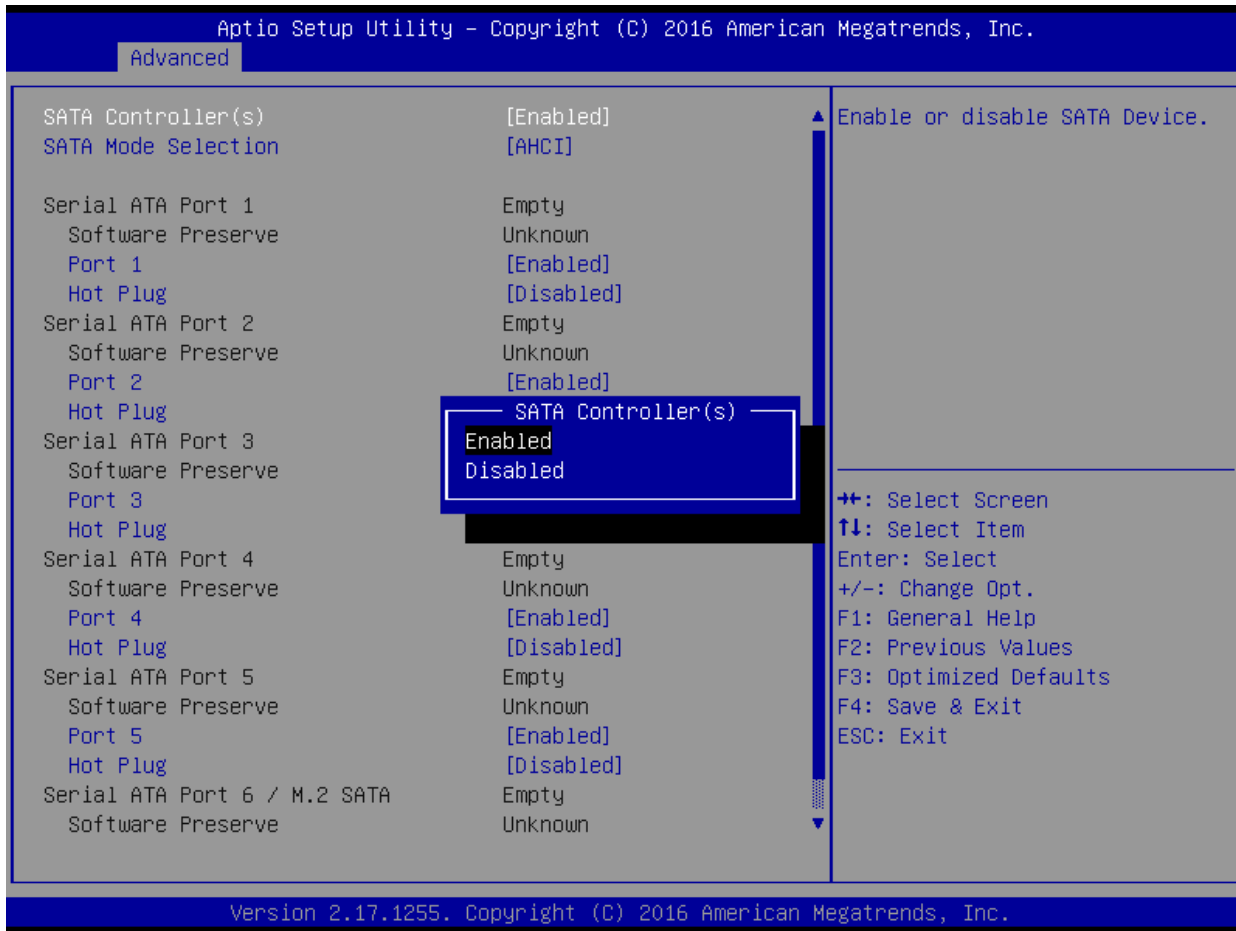

- SATA Controller [Enabled]**
 Enable or Disable SATA device
 Configuration options: [Enabled][Disabled]
- SATA Mode Selection [AHCI]**
 Determines how SATA controller operate
 Configuration options: [AHCI][RAID]
- Port 1 [Enabled]**
 Enable or Disable SATA port 1
 Configuration options: [Enabled][Disabled]
- Hot Plug [Disabled]**
 Designates this port as Hot Pluggable
 Configuration options: [Disabled][Enabled]
- Port 2 [Enabled]**
 Enable or Disable SATA port 2
 Configuration options: [Enabled][Disabled]
- Hot Plug [Disabled]**
 Designates this port as Hot Pluggable
 Configuration options: [Disabled][Enabled]
- Port 3 [Enabled]**

Enable or Disable SATA port 3

Configuration options: [Enabled][Disabled]

- **Hot Plug [Disabled]**

Designates this port as Hot Pluggable

Configuration options: [Disabled][Enabled]

- **Port 4 [Enabled]**

Enable or Disable SATA port 4

Configuration options: [Enabled][Disabled]

- **Hot Plug [Disabled]**

Designates this port as Hot Pluggable

Configuration options: [Disabled][Enabled]

- **Port 5 [Enabled]**

Enable or Disable SATA port 5

Configuration options: [Enabled][Disabled]

- **Hot Plug [Disabled]**

Designates this port as Hot Pluggable

Configuration options: [Disabled][Enabled]

- **Port 6 [Enabled]**

Enable or Disable SATA port 6

Configuration options: [Enabled][Disabled]

- **Hot Plug [Disabled]**

Designates this port as Hot Pluggable

Configuration options: [Disabled][Enabled]

2.4.11 AMI Graphic Output Protocol Policy

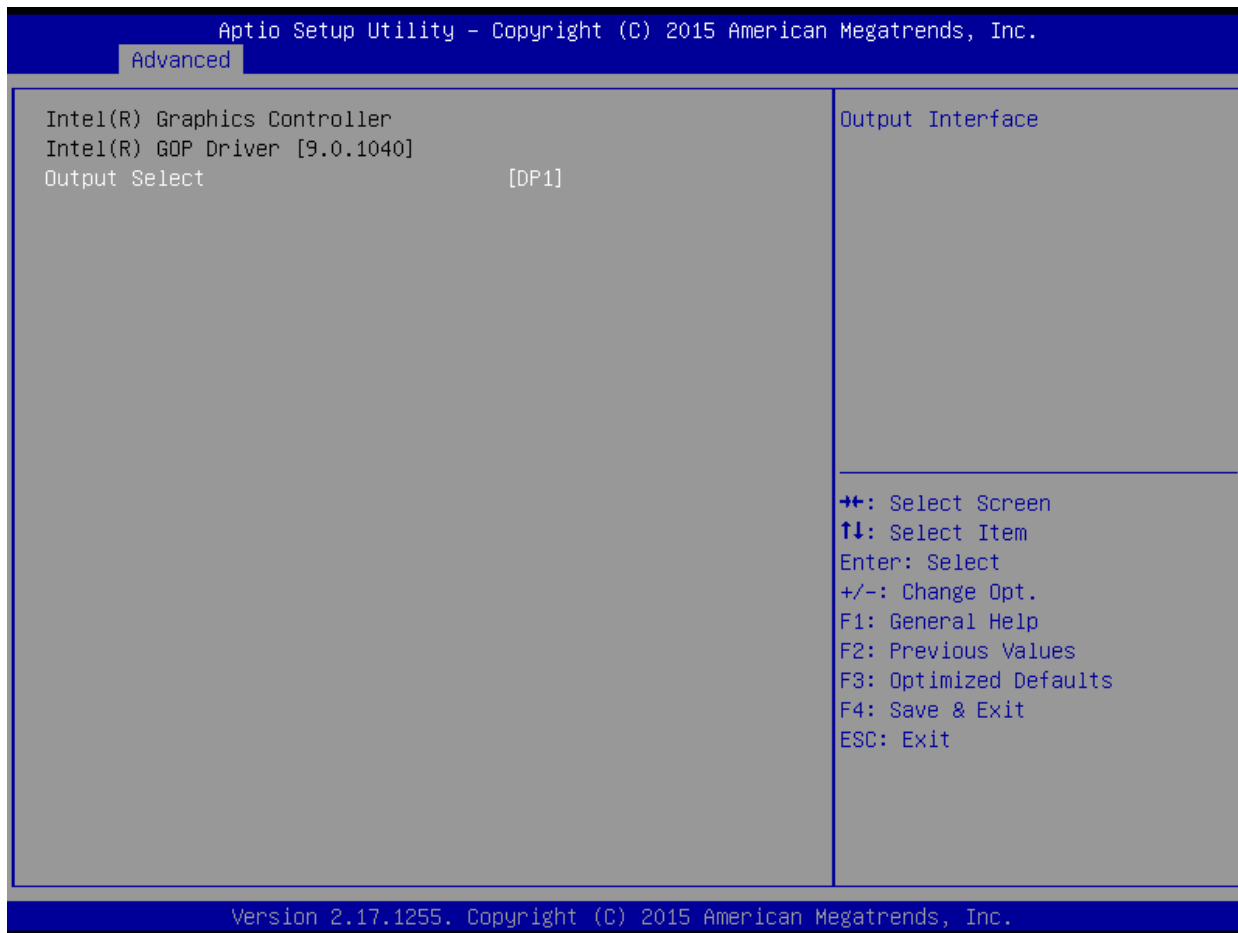

- **Output Select [DP1]**
Output interface Selection.
Configuration Selection: It depends on what kind of monitor you connect to this board.
Once you select, there will be single display under BIOS mode.

2.4.12 Network Stack Configuration

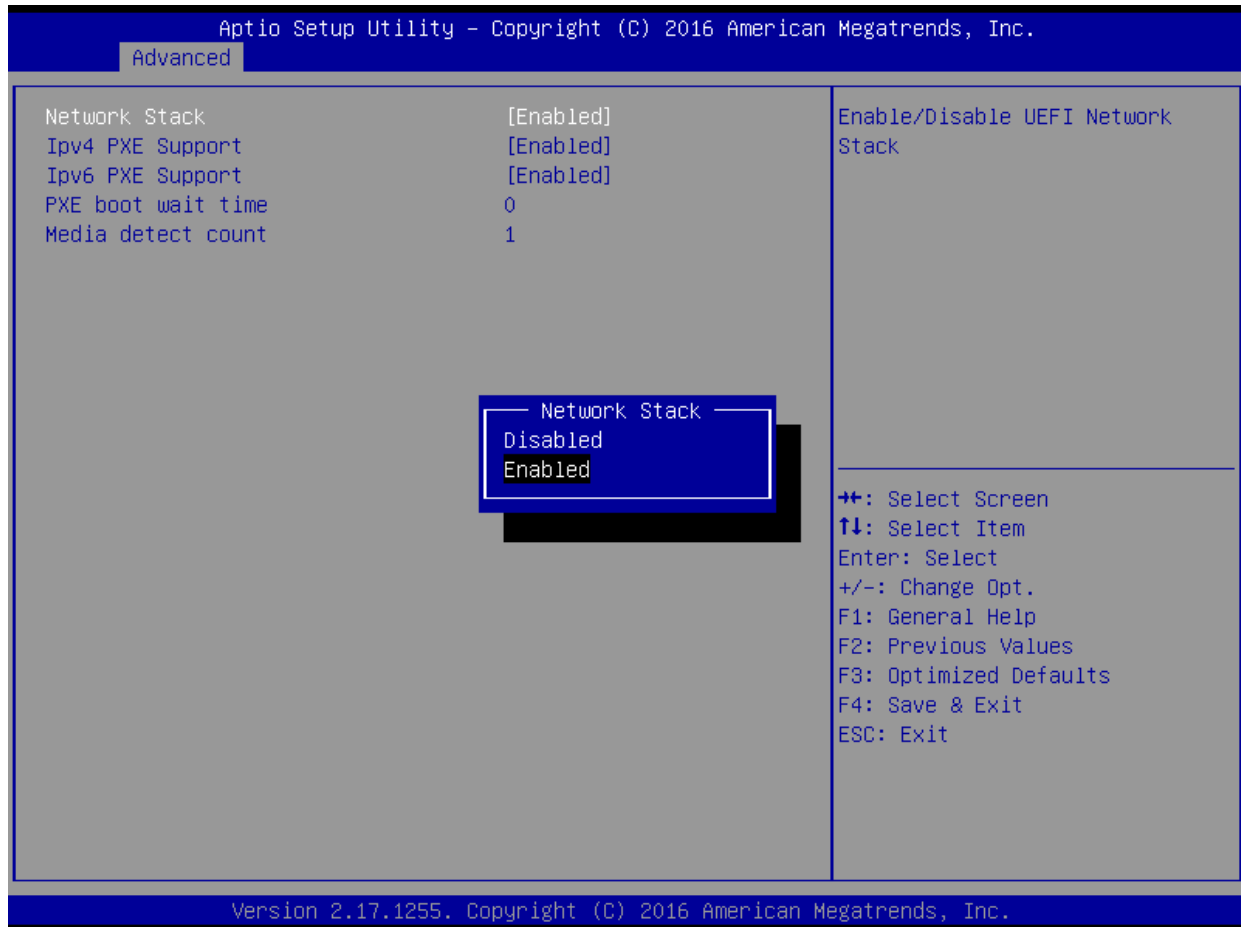

- **Network Stack [Disabled]**
Enabled or disabled UEFI Network Stack
Configuration options: [Disabled] [Enabled]
- **Ipv4 PXE Support [Enabled]**
Enabled IPv4 PXE boot support
Configuration options: [Disabled] [Enabled]
- **Ipv6 PXE Support [Enabled]**
Enabled IPv6 PXE boot support
Configuration options: [Disabled] [Enabled]
- **PXE boot wait time**
Wait time to press ESC to abort the PXE boot
- **Media Detect Count**
Number of times presence of media will be checked

2.4.13 Compatibility Support Module Configuration

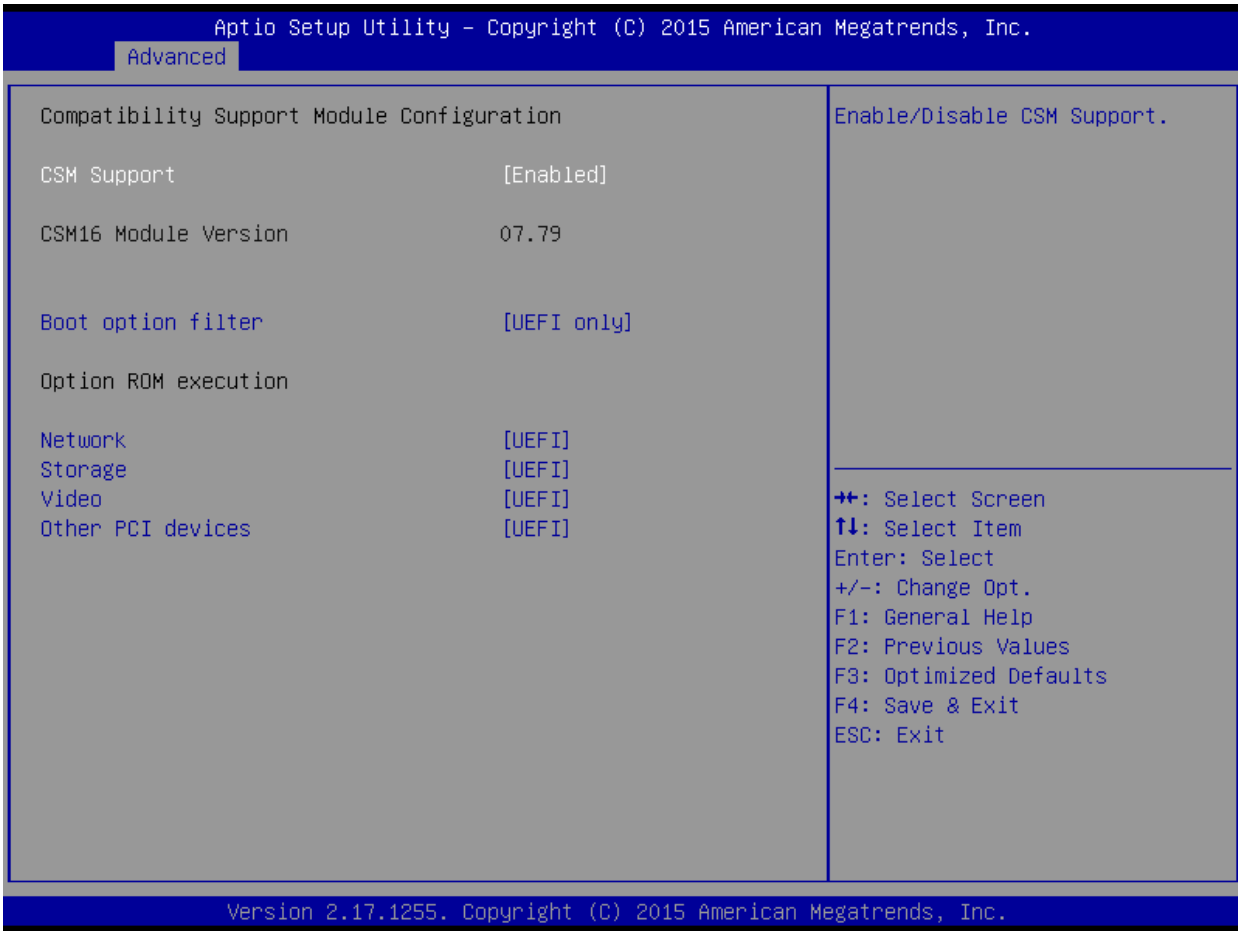

- **CSM Support [Enabled]**

Enabled or disabled CSM Support

Configuration options: [Disabled] [Enabled]

- **Boot option Filter [UEFI Only]**

This option controls Legacy/UEFI ROMs Priority

Configuration options: [UEFI and Legacy] [Legacy Only][UEFI Only]

- **Network [UEFI]**

Control the execution of UEFI and Legacy PXE OpROM

Configuration options: [Do not launch] [UEFI][Legacy]

- **Storage [UEFI]**

Control the execution of UEFI and Legacy Storage OpROM

Configuration options: [Do not launch] [UEFI][Legacy]

- **Video [UEFI]**

Control the execution of UEFI and Legacy Video OpROM

Configuration options: [Do not launch] [UEFI][Legacy]

- **Other PCI devices [UEFI]**

Determines OpROM execution policy for devices other than Network, Storage, or Video.

Configuration options: [Do not launch] [UEFI][Legacy]

2.4.14 NVMe Configuration

Display NVMe controller or Drive information



RX170Q User's Manual
2.4.15 USB Configuration
USBConfiguration parameters

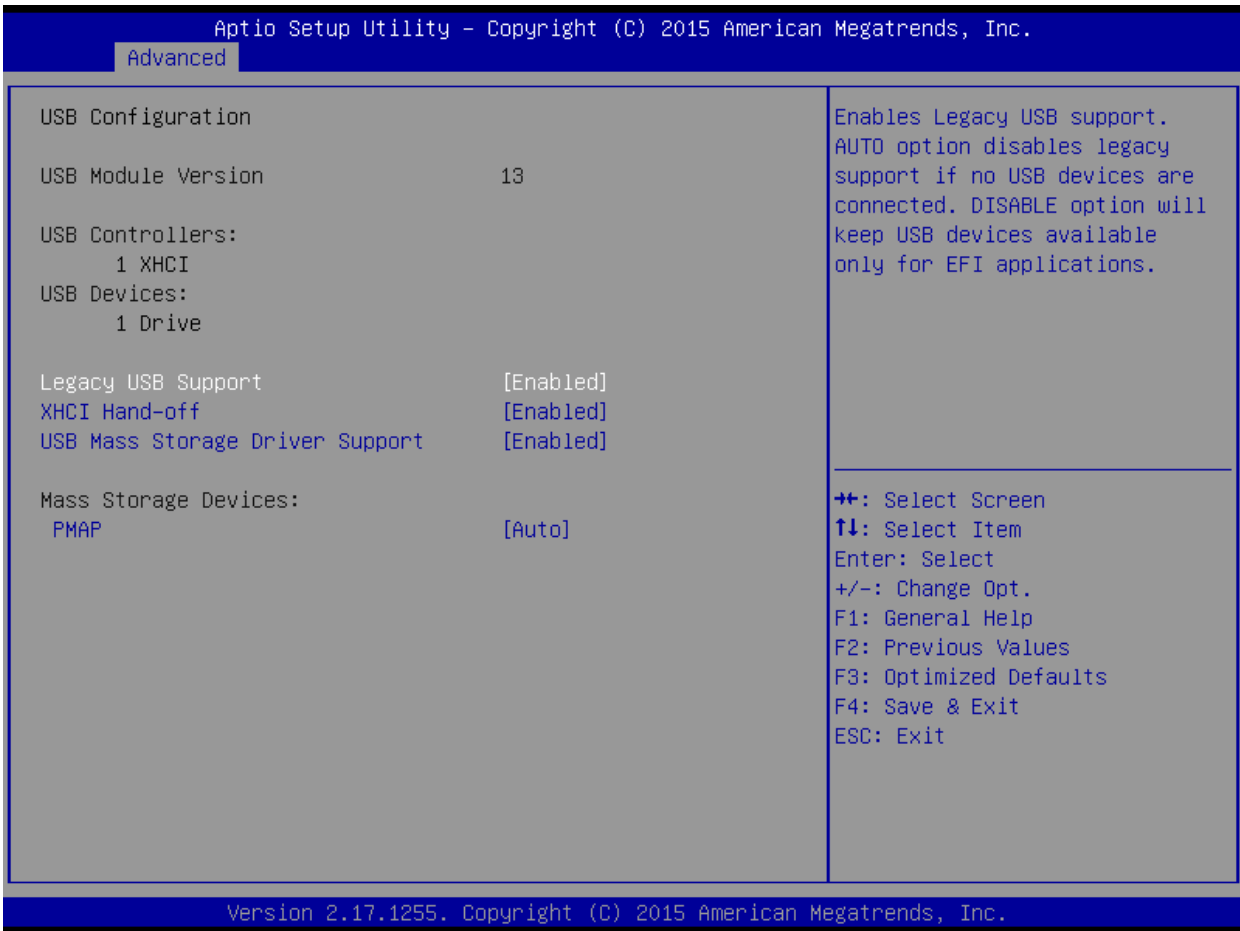

- **Legacy USB Support [Enabled]**

Enabled Legacy USB Support. Auto Option disables legacy support if no USB devices are connected. Disabled option will keep USB devices available only for EFI application.

Configuration options: [Disabled] [Enabled][Auto]

- **XHCI Hand-off [Enabled]**

This is a workaround for Oses without XHCI hand-off support. This XHCI ownership change should be claimed by XHCI drivers

Configuration options: [Disabled] [Enabled]

- **USB Mass storage Driver Support[Enabled]**

Enabled or Disabled USB Mass storage driver support.

Configuration options: [Disabled] [Enabled]

- **PMAP[Auto]**

Mass storage device emulation type. 'Auto' enumerates devices according to their media format. Optical drives are emulated as 'CDROM', drives with no media will be emulated according to a drive type.

Configuration options: [Auto] [Floopy][Forced FDD][hard Disk][CD-ROM]

2.5 Chipset

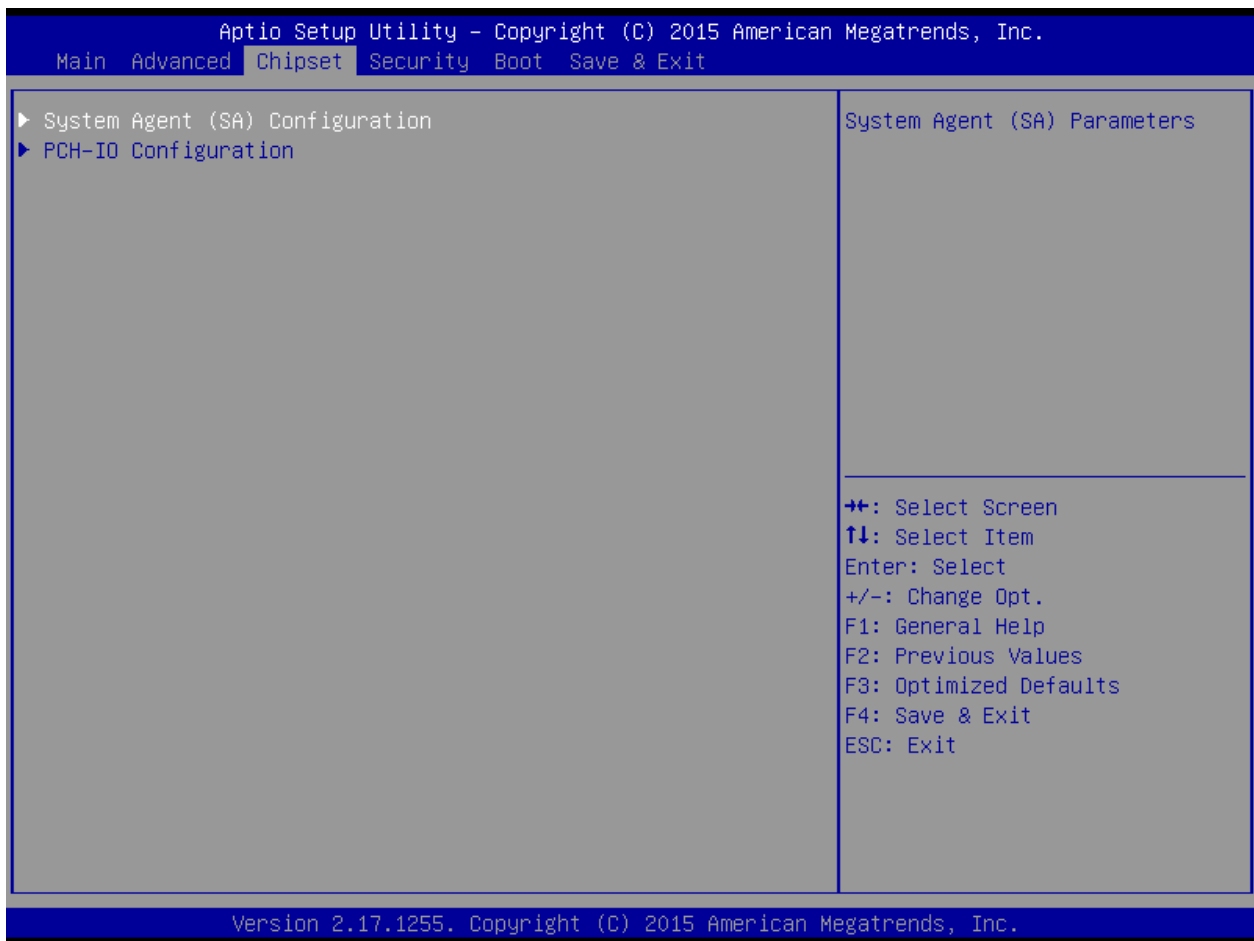

RX170Q User's Manual

2.5.1 System Agent (SA) Configuration

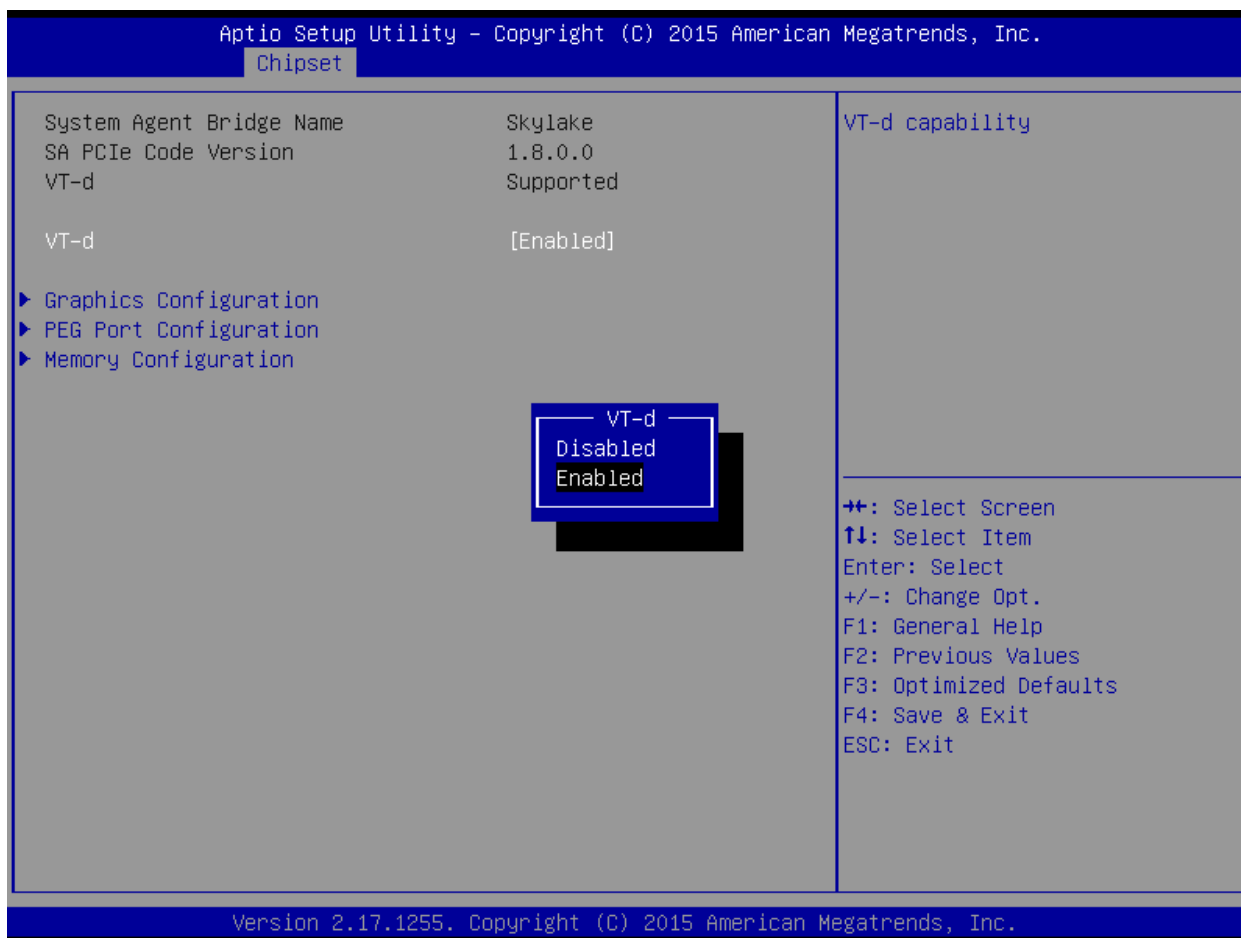

- **VT-d [Enabled]**

VT-d capability

Configuration options: [Disabled] [Enabled]

2.5.1.1 Graphic Configuration

Graphic configuration settings

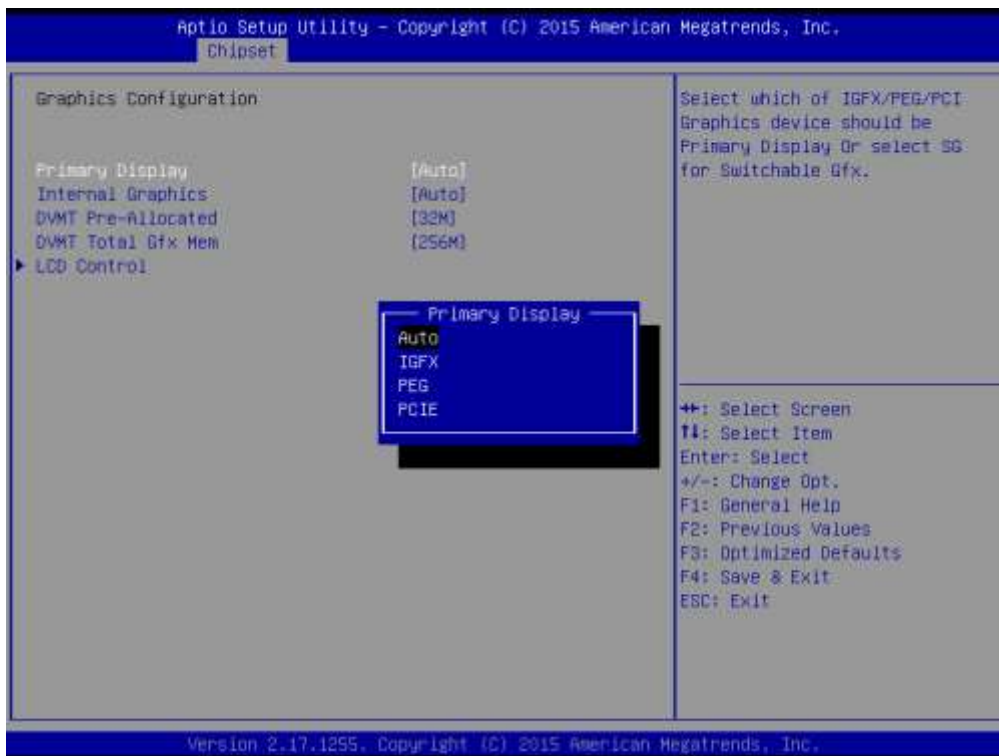

- Primary Display[Auto]**
 Select which of IGFX/PEG/PCI graphic device should be primary display or select SG for switchable GFx.
 Configuration options: [Auto] [IGFX][PEG][PCIE]
- Internal Graphics [Auto]**
 Keep IGFX enabled based on the setup options
 Configuration options: [Auto] [disabled][enabled]
- DVMT Pre-allocated [32M]**
 Select DVMT 5.0 Pre-allocated (Fixed) Graphics memory size used by the internal graphics device.
 Configuration options: As below picture

RX170Q User's Manual

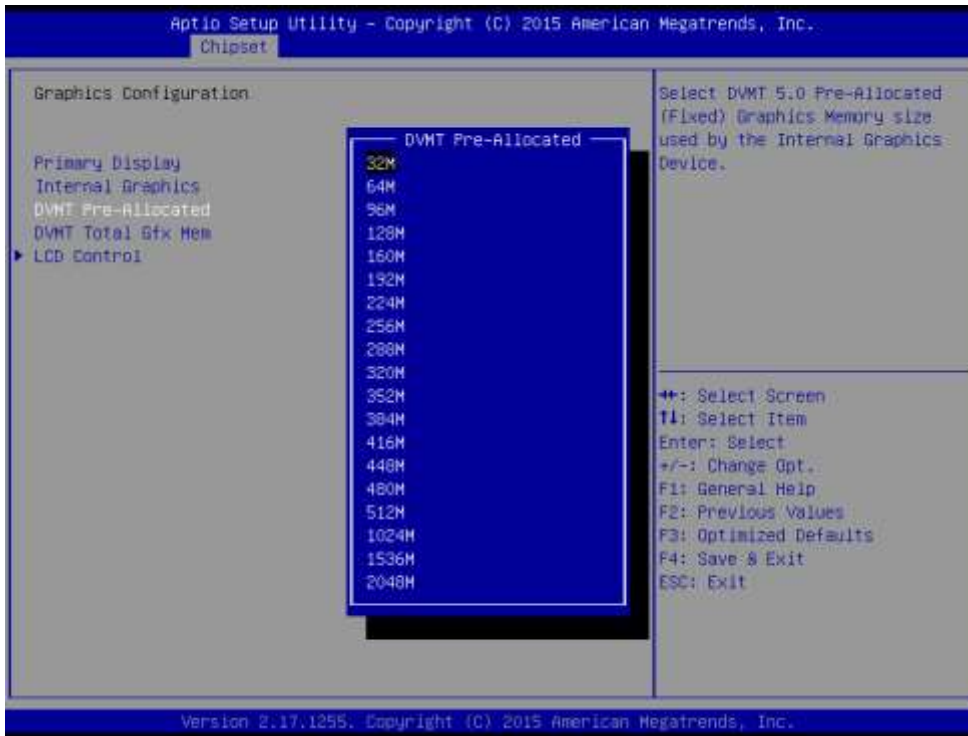

- **DVMT total Gfx Mem [256M]**
Select DVMT 5.0 Total graphic memory size used by the internal graphic device
Configuration options: [128M][256M][Max]

2.5.1.1.1 LCD Control

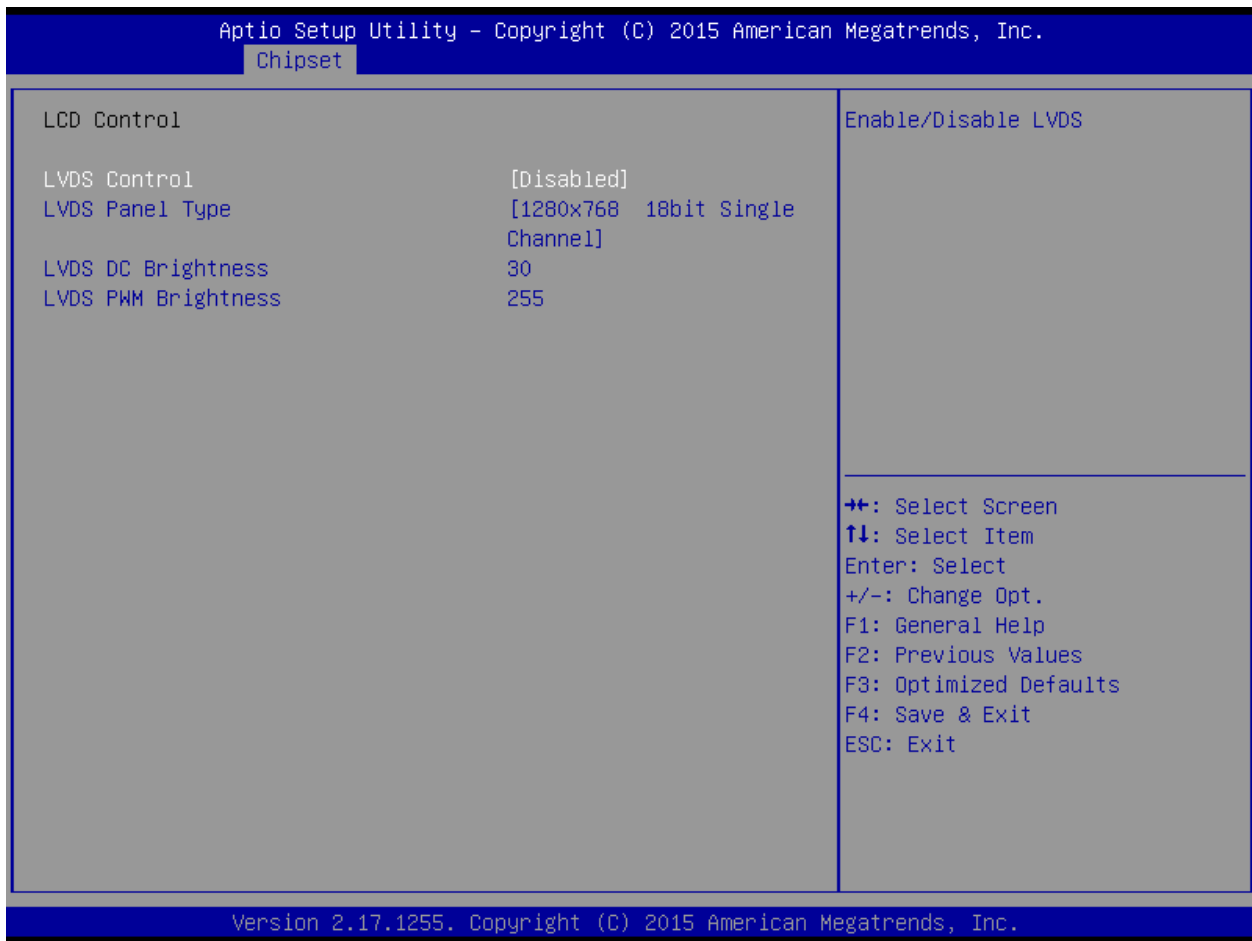

- **LVDS Control [Disabled]**
 Enabled or Disabled LVDS
 Configuration options: [Enabled][Disabled]
- **LVDS panel Type[1280x760 18bit single channel]**
 Select LVDS panel type
 Configuration options: See below picture

RX170Q User's Manual

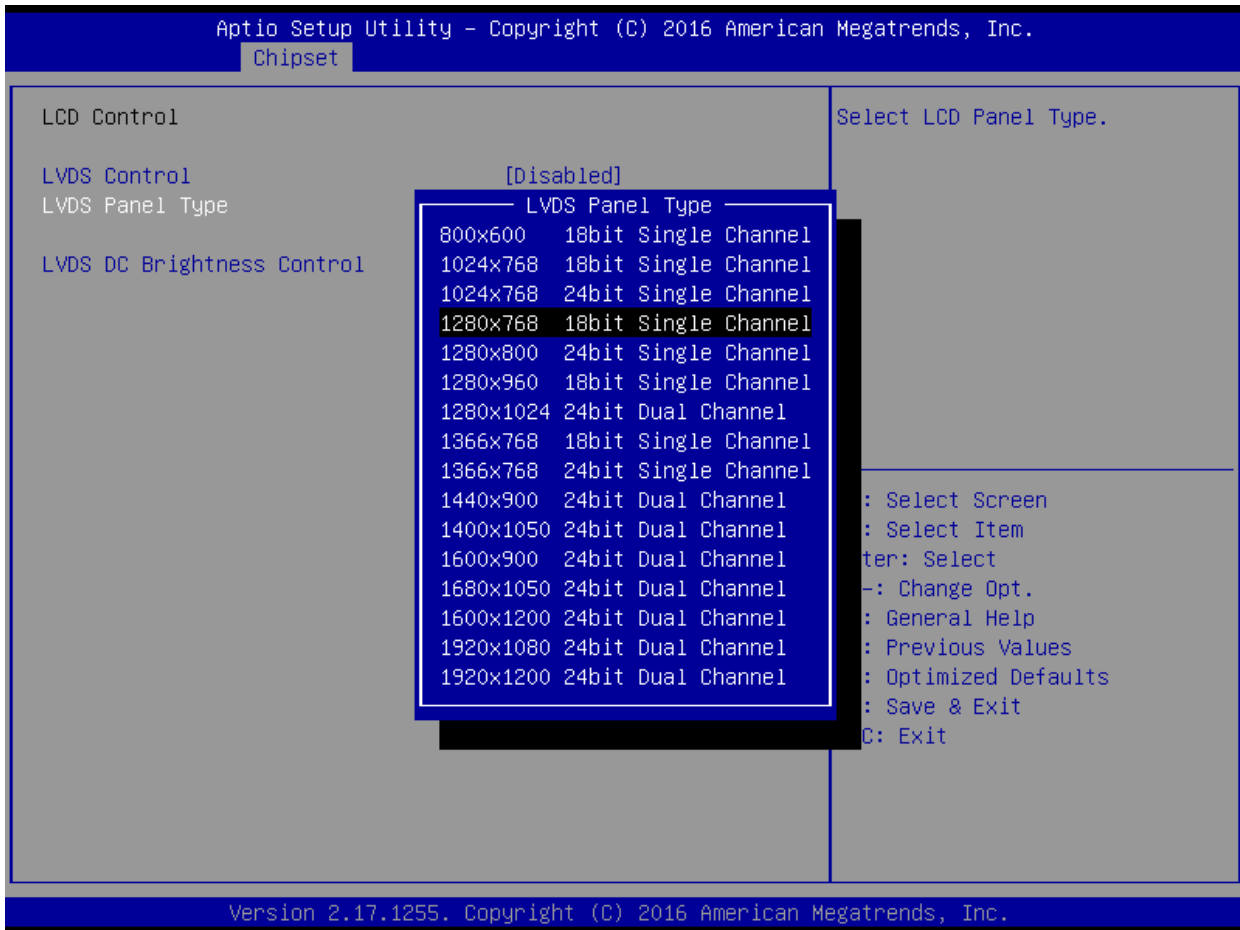

- **LVDS DC brightness:30**
LVDS DC brightness value from 1 to 63.
- **LVDS PWM brightness:30**
LVDS PWM brightness value from 0 to 255.

2.5.1.2 PEG Port Configuration

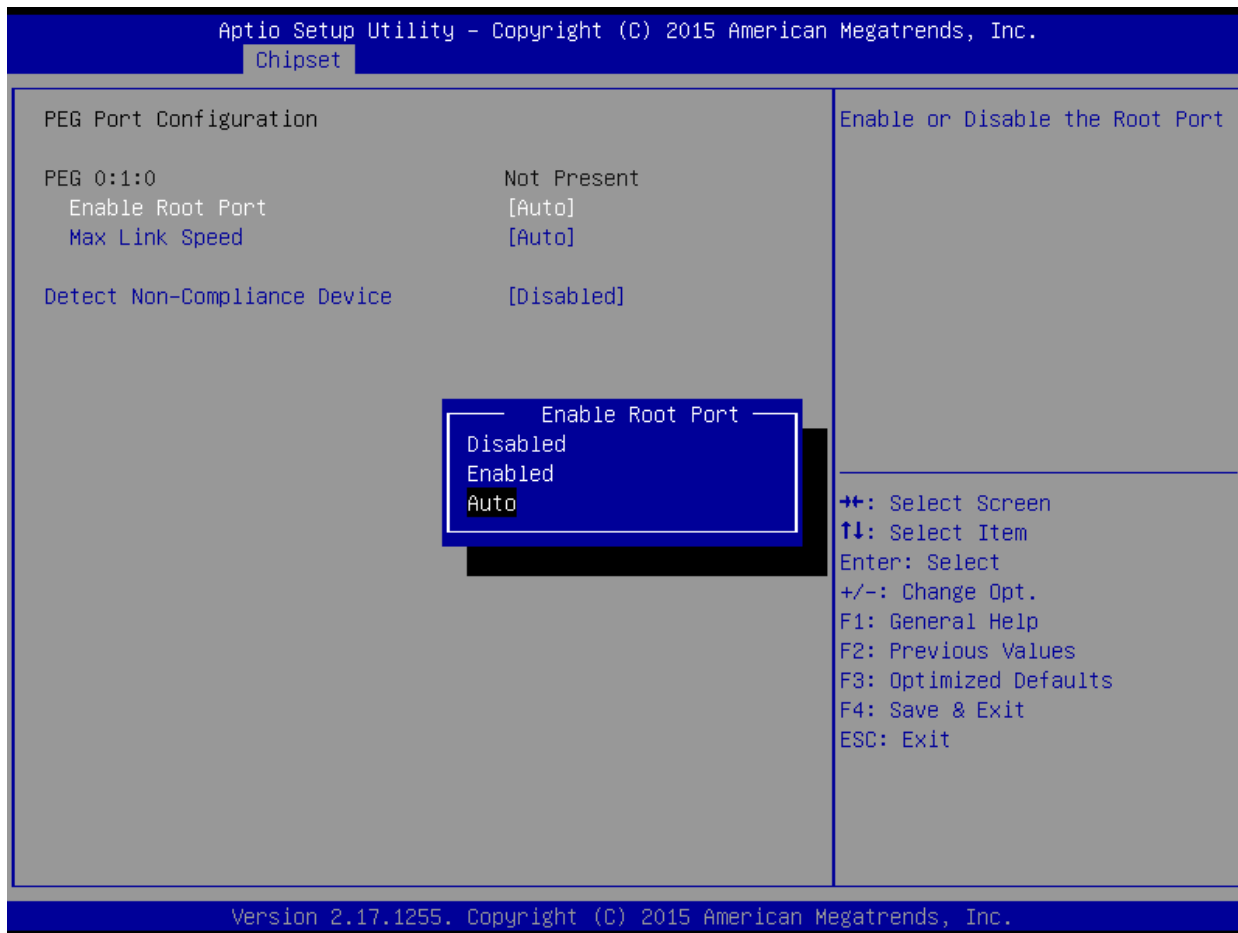

- Enable root Port [Auto]**
 Enable or Disable the root port
 Configuration options: [Disabled][Enabled][Auto]
- Max Link Speed [Auto]**
 Configure PEG 0:1:0 Max Speed
 Configuration options: [Auto][Gen1][Gen2][Gen3]
- Detect Non-Compliance Device [Disabled]**
 Detect non-compliance PCI express Device in PEG
 Configuration options: [Disabled][Enabled]

RX170Q User's Manual

2.5.1.3 Memory configuration

Display memory information

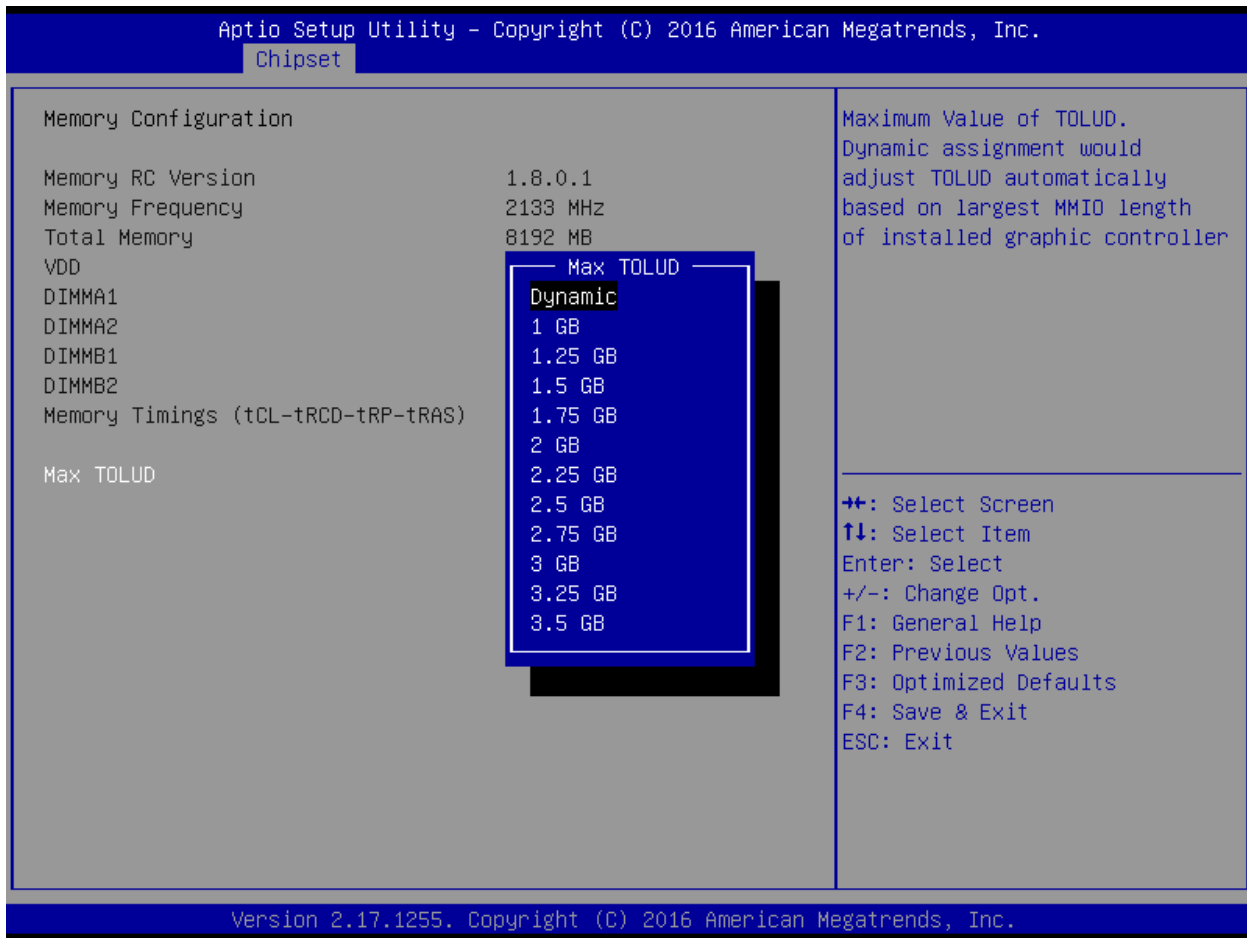

- **Max TOLUD [Dynamic]**
Maximum value of TOLUD.
Configuration options: As above picture

2.5.2 PCH-IO configuration

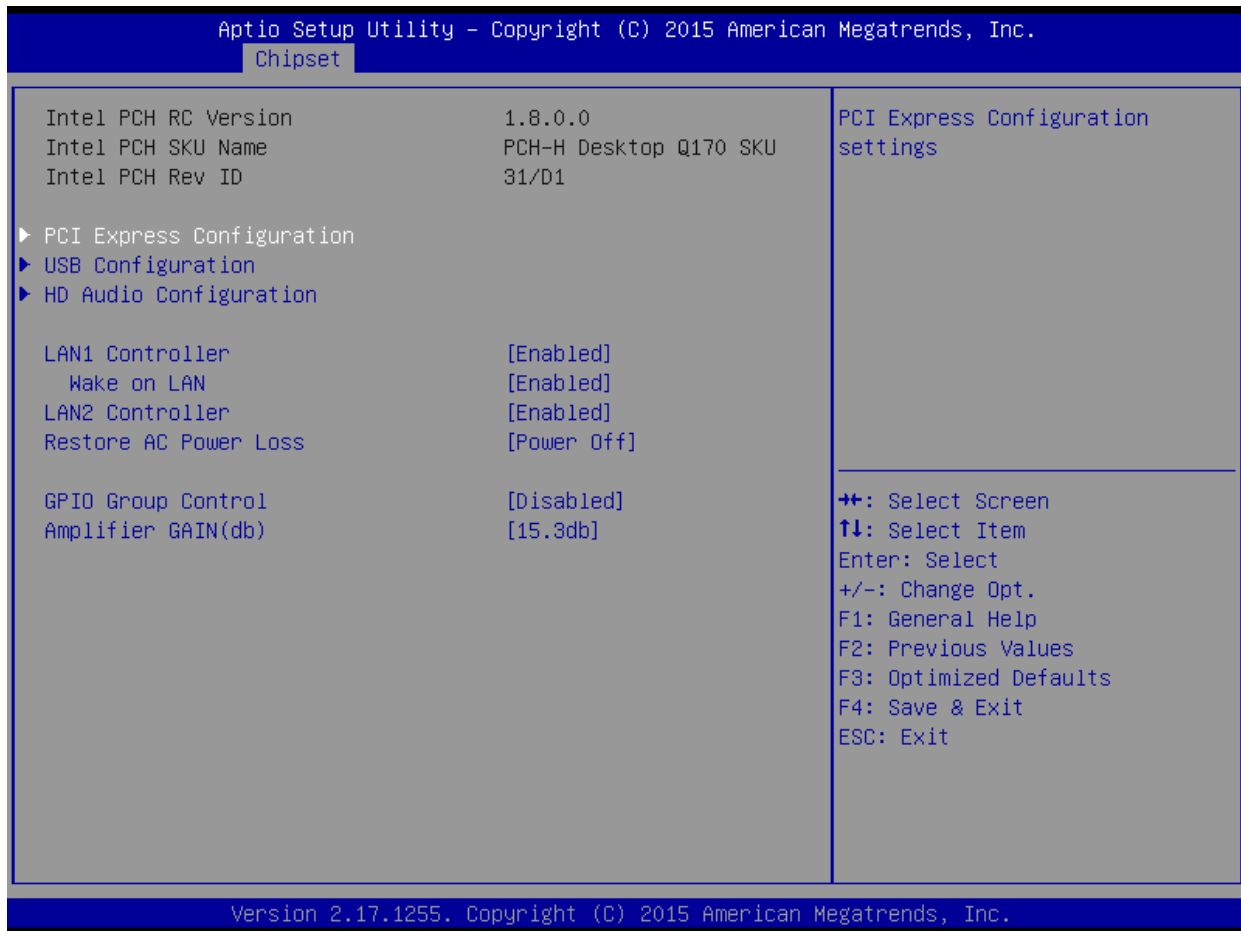

- Lan1 Controller [Enabled]**
 Enable or Disable onboard Lan1
 Configuration options: [Disabled][Enabled]
- Wake on lan [Auto]**
 Enable or Disable integrated LAN to wake the system
 Configuration options: [Disabled][Enabled]
- Lan2 Controller [Enabled]**
 Enable or Disable onboard Lan2
 Configuration options: [Disabled][Enabled]
- Restore AC power Loss [Power off]**
 Specify what state to go to when power is re-applied after a power failure.
 Configuration options: [Power on][Power off][Last State]
- GPIO Group Control [Disabled]**
 Configure the digital GPIO pins
 Configuration options: [Disabled][Enabled]
- Amplifier GAIN(db) [15.3db]**
 Select Amplifier GAIN value
 Configuration options: [15.3db][21.2db][27.2db][31.8db]

2.5.2.1 PCI Express configuration

2.5.2.1.1 PCI Express Root Port 1

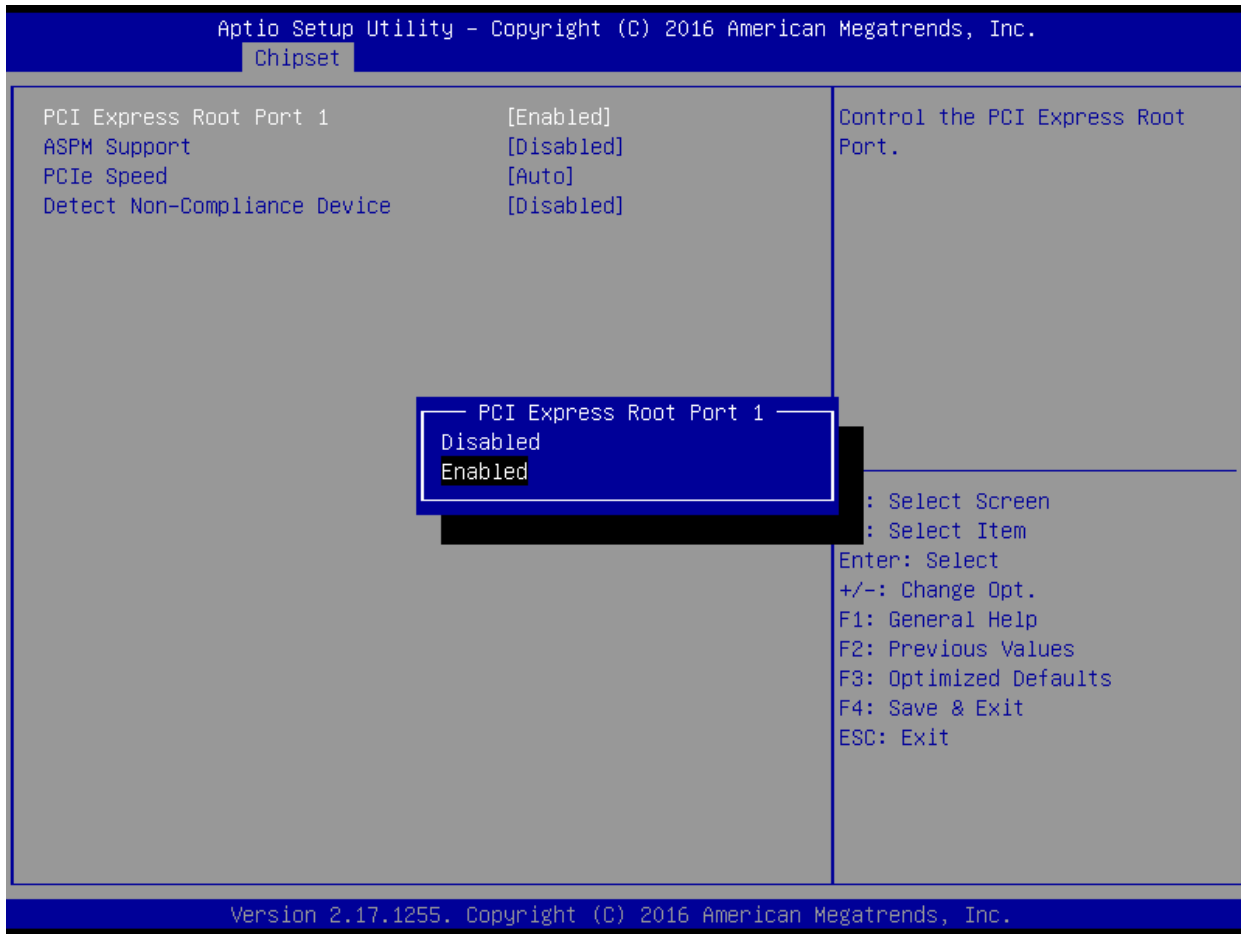

- **PCI Express Root Port 1 [Enabled]**
Control the PCI Express Port
Configuration options: [Disabled][Enabled]
- **ASPM Support [Disabled]**
Set the ASPM level: Force L0s- Force all links to L0s State; Auto- BIOS auto configure;
Disabled- Disables ASPM
Configuration options: [Disabled][L0s][L1][L0sL2][Auto]
- **PCIe Speed [Auto]**
Select PCI Express Port speed
Configuration options: [Auto][Gen1][Gen2][Gen3]
- **Detect Non-compliance device [Disabled]**
Detect non-compliance PCI express Device, If enabled, it will take more time at Post time.
Configuration options: [Disabled][Enabled]

2.5.2.1.2 PCI Express Root Port 6

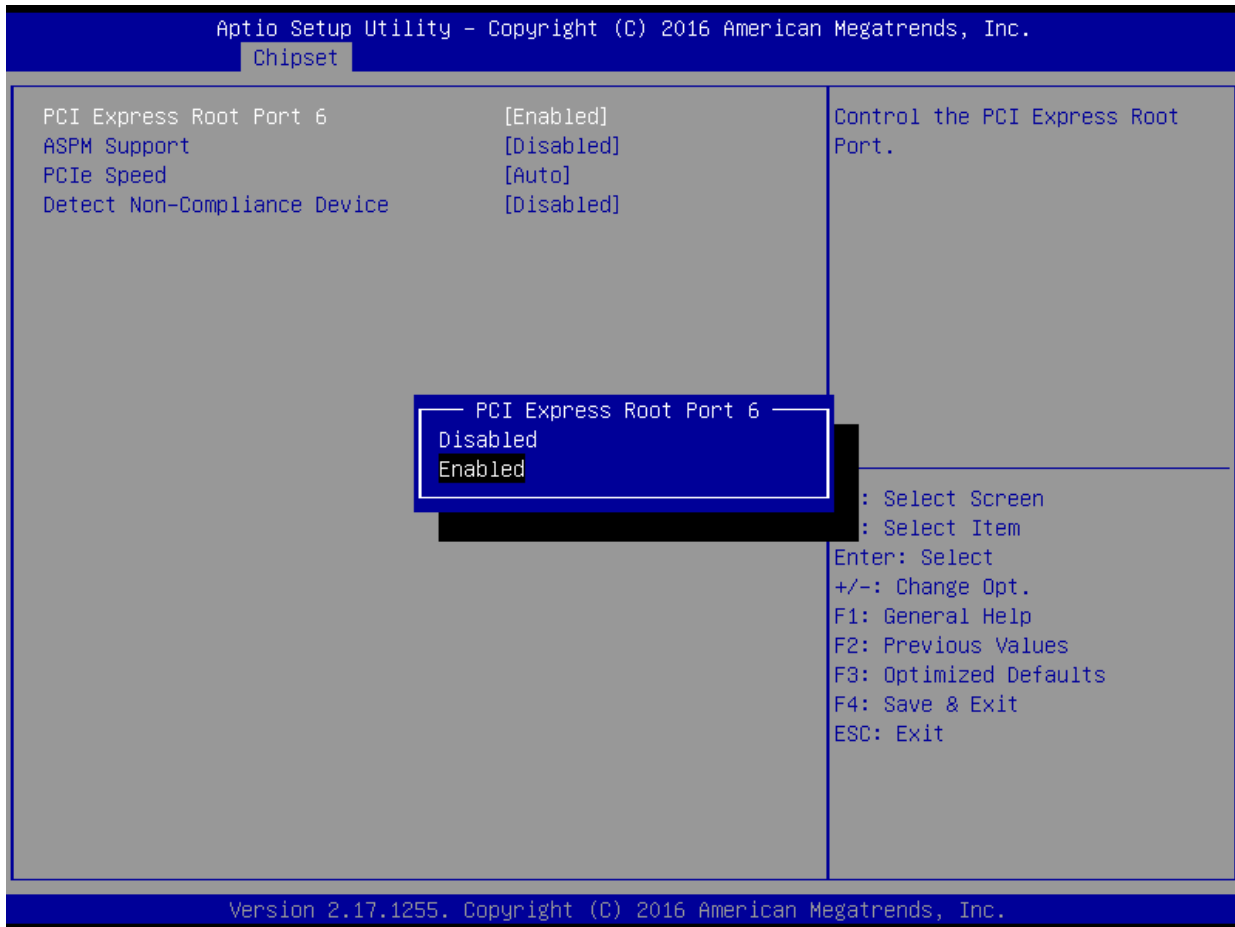

- PCI Express Root Port 6 [Enabled]**
 Control the PCI Express Port
 Configuration options: [Disabled][Enabled]
- ASPM Support [Disabled]**
 Set the ASPM level: Force L0s- Force all links to L0s State; Auto- BIOS auto configure;
 Disabled- Disables ASPM
 Configuration options: [Disabled][L0s][L1][L0sL2][Auto]
- PCIe Speed [Auto]**
 Select PCI Express Port speed
 Configuration options: [Auto][Gen1][Gen2][Gen3]
- Detect Non-compliance device [Disabled]**
 Detect non-compliance PCI express Device, If enabled, it will take more time at Post time.
 Configuration options: [Disabled][Enabled]

RX170Q User's Manual

2.5.2.1.3 PCI Express Root Port 7

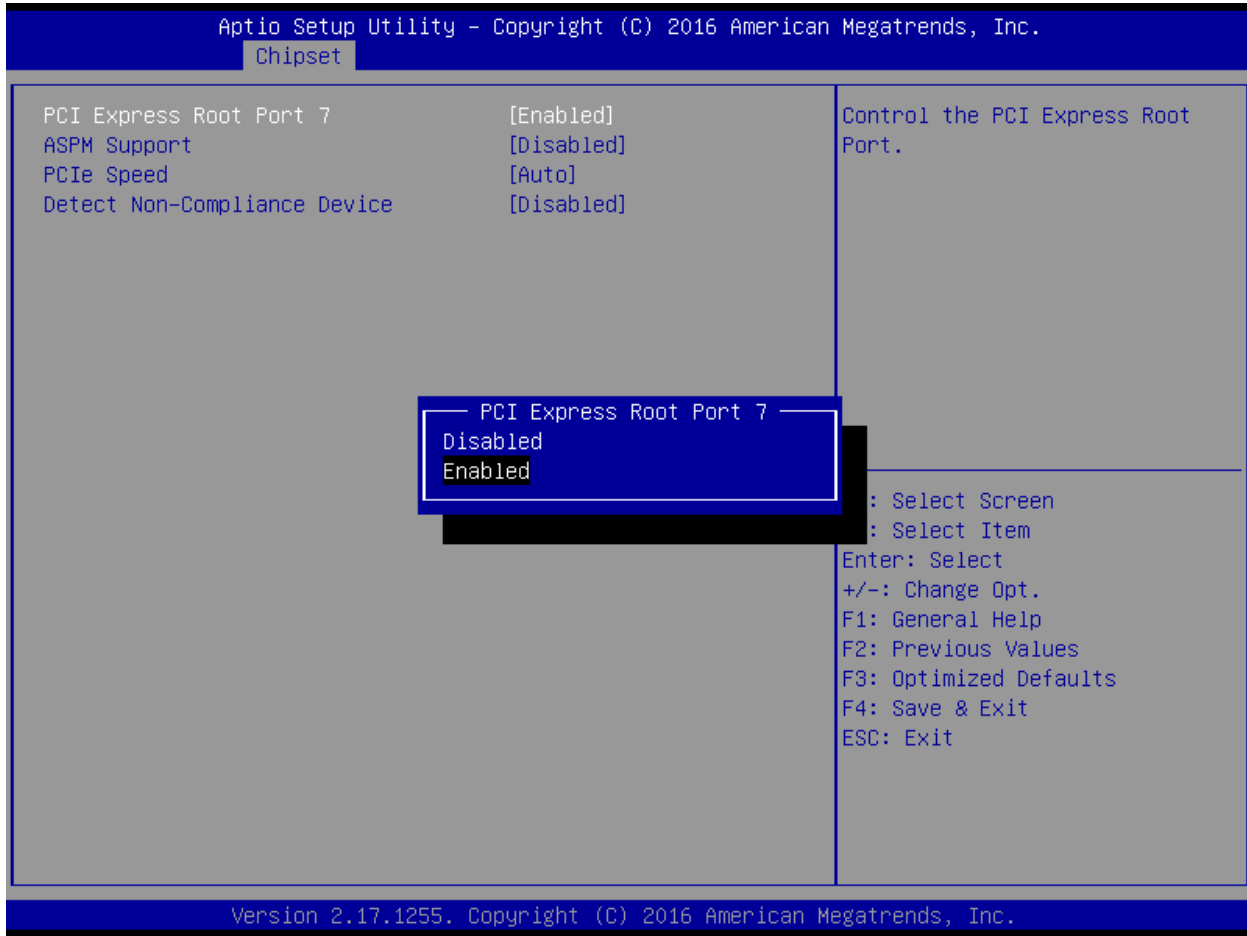

- PCI Express Root Port 7 [Enabled]**
 Control the PCI Express Port
 Configuration options: [Disabled][Enabled]
- ASPM Support [Disabled]**
 Set the ASPM level: Force L0s- Force all links to L0s State; Auto- BIOS auto configure; Disabled- Disables ASPM
 Configuration options: [Disabled][L0s][L1][L0sL2][Auto]
- PCIe Speed [Auto]**
 Select PCI Express Port speed
 Configuration options: [Auto][Gen1][Gen2][Gen3]
- Detect Non-compliance device [Disabled]**
 Detect non-compliance PCI express Device, If enabled, it will take more time at Post time.
 Configuration options: [Disabled][Enabled]

2.5.2.1.4 PCI Express Root Port 9

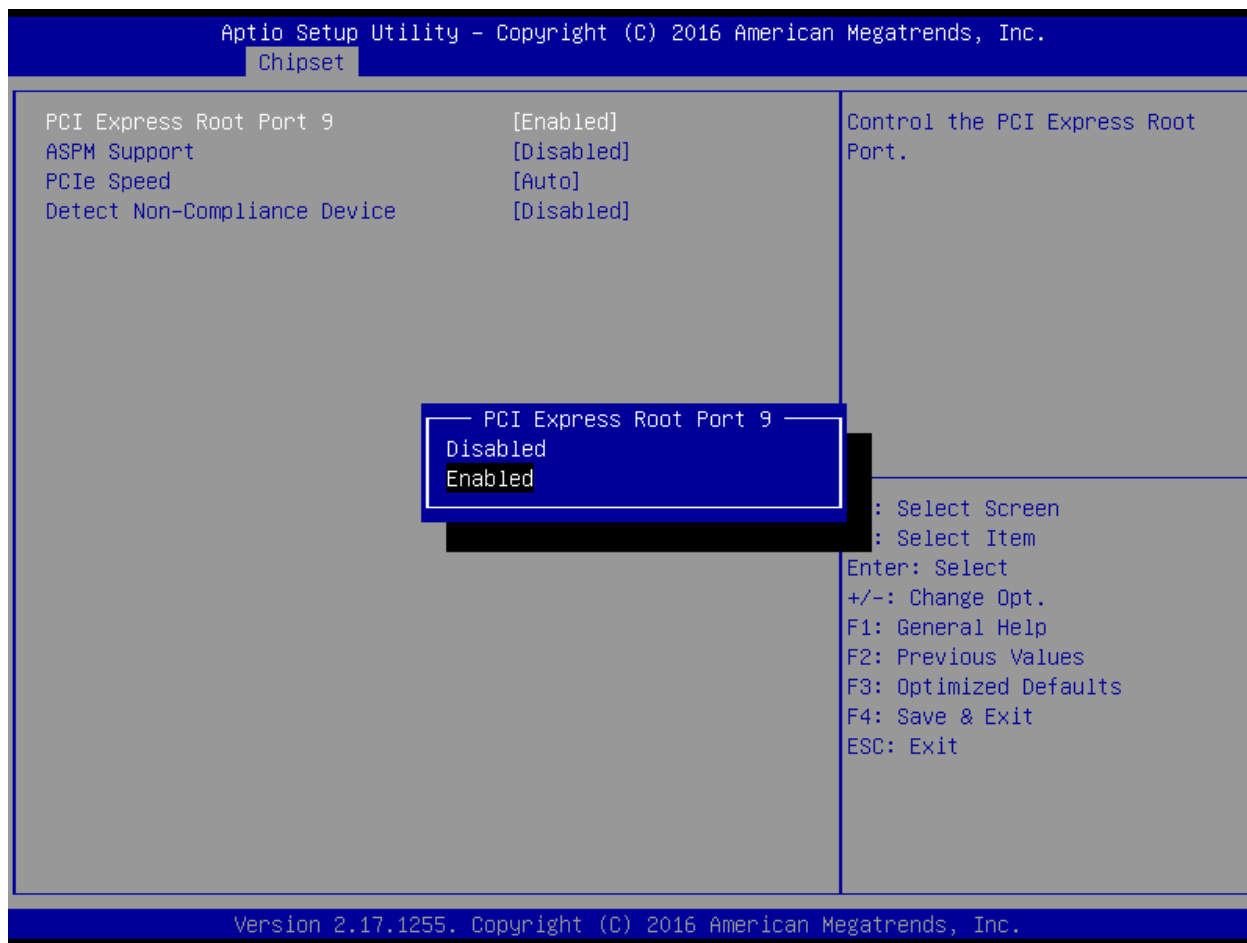

- PCI Express Root Port 9 [Enabled]**
 Control the PCI Express Port
 Configuration options: [Disabled][Enabled]
- ASPM Support [Disabled]**
 Set the ASPM level: Force L0s- Force all links to L0s State; Auto- BIOS auto configure;
 Disabled- Disables ASPM
 Configuration options: [Disabled][L0s][L1][L0sL2][Auto]
- PCIe Speed [Auto]**
 Select PCI Express Port speed
 Configuration options: [Auto][Gen1][Gen2][Gen3]
- Detect Non-compliance device [Disabled]**
 Detect non-compliance PCI express Device, If enabled, it will take more time at Post time.
 Configuration options: [Disabled][Enabled]

RX170Q User's Manual

2.5.2.1.5 PCI Express Root Port 13

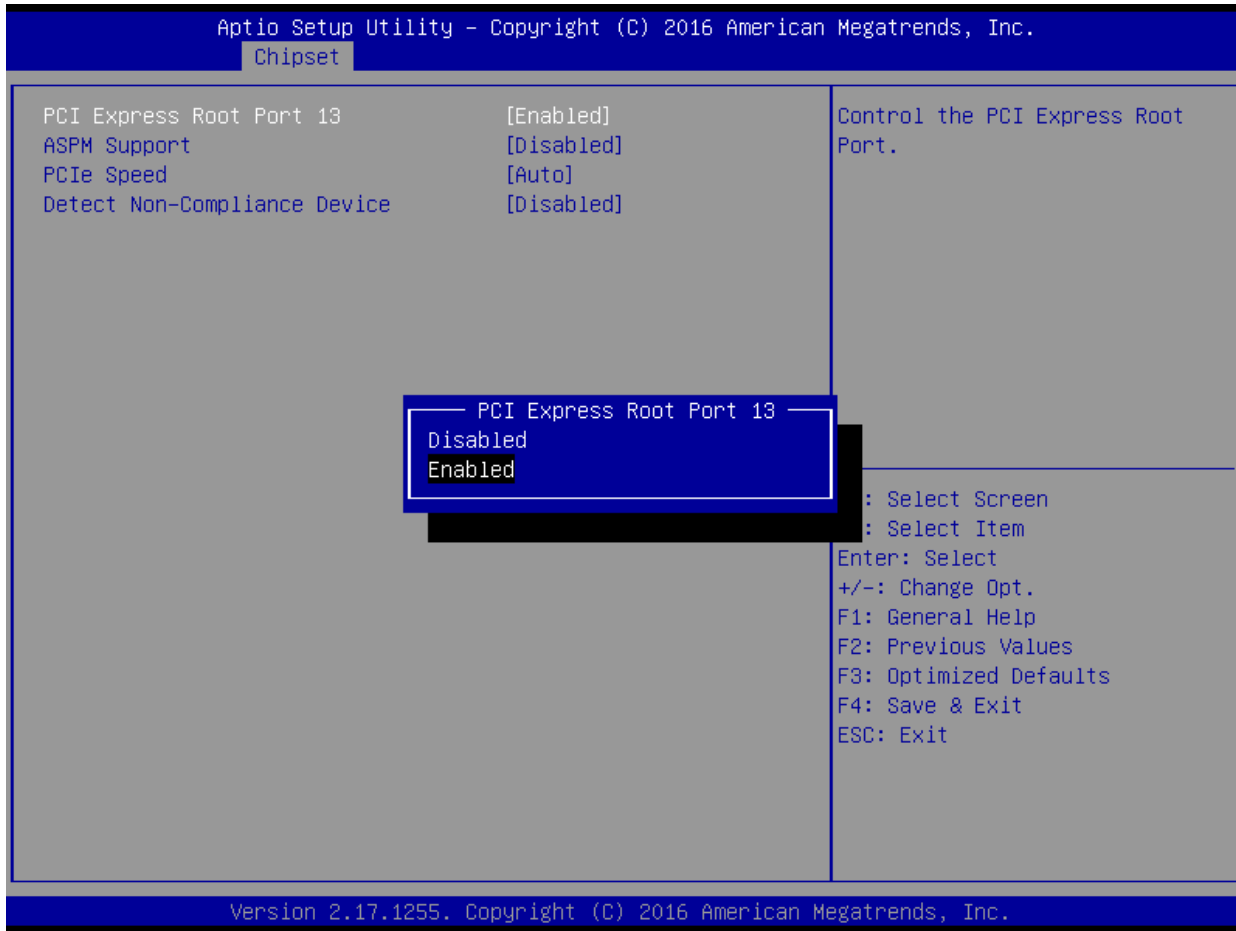

- PCI Express Root Port 13 [Enabled]**
 Control the PCI Express Port
 Configuration options: [Disabled][Enabled]
- ASPM Support [Disabled]**
 Set the ASPM level: Force L0s- Force all links to L0s State; Auto- BIOS auto configure; Disabled- Disables ASPM
 Configuration options: [Disabled][L0s][L1][L0sL2][Auto]
- PCIe Speed [Auto]**
 Select PCI Express Port speed
 Configuration options: [Auto][Gen1][Gen2][Gen3]
- Detect Non-compliance device [Disabled]**
 Detect non-compliance PCI express Device, If enabled, it will take more time at Post time.
 Configuration options: [Disabled][Enabled]

2.5.2.2 USB configuration

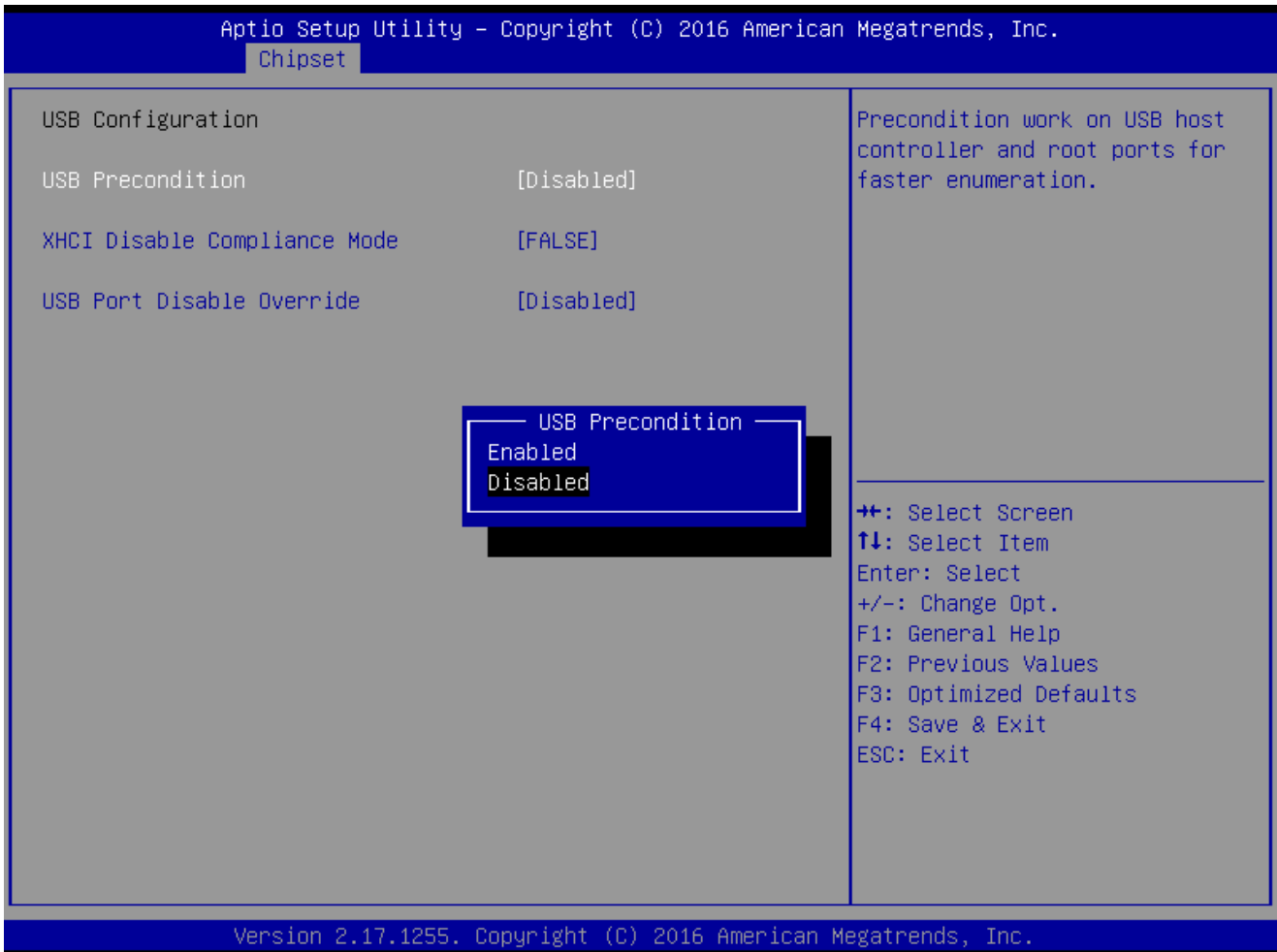

- USB Precondition[Disabled]**
 Precondition work on USB host controller and root ports for faster enumeration
 Configuration options: [Disabled] [Enabled]
- XHCI Disabled Compliance Mode [False]**
 Options to disable compliance mode.
 Configuration options: [False][true]
- USB Port Disable override [Disabled]**
 Select Enabled/Disabled the corresponding USB port from reporting a device connection to the controller.
 Configuration options: [Disabled] [Select Per-Pin]

RX170Q User's Manual

2.5.2.3 HD audio Configuration

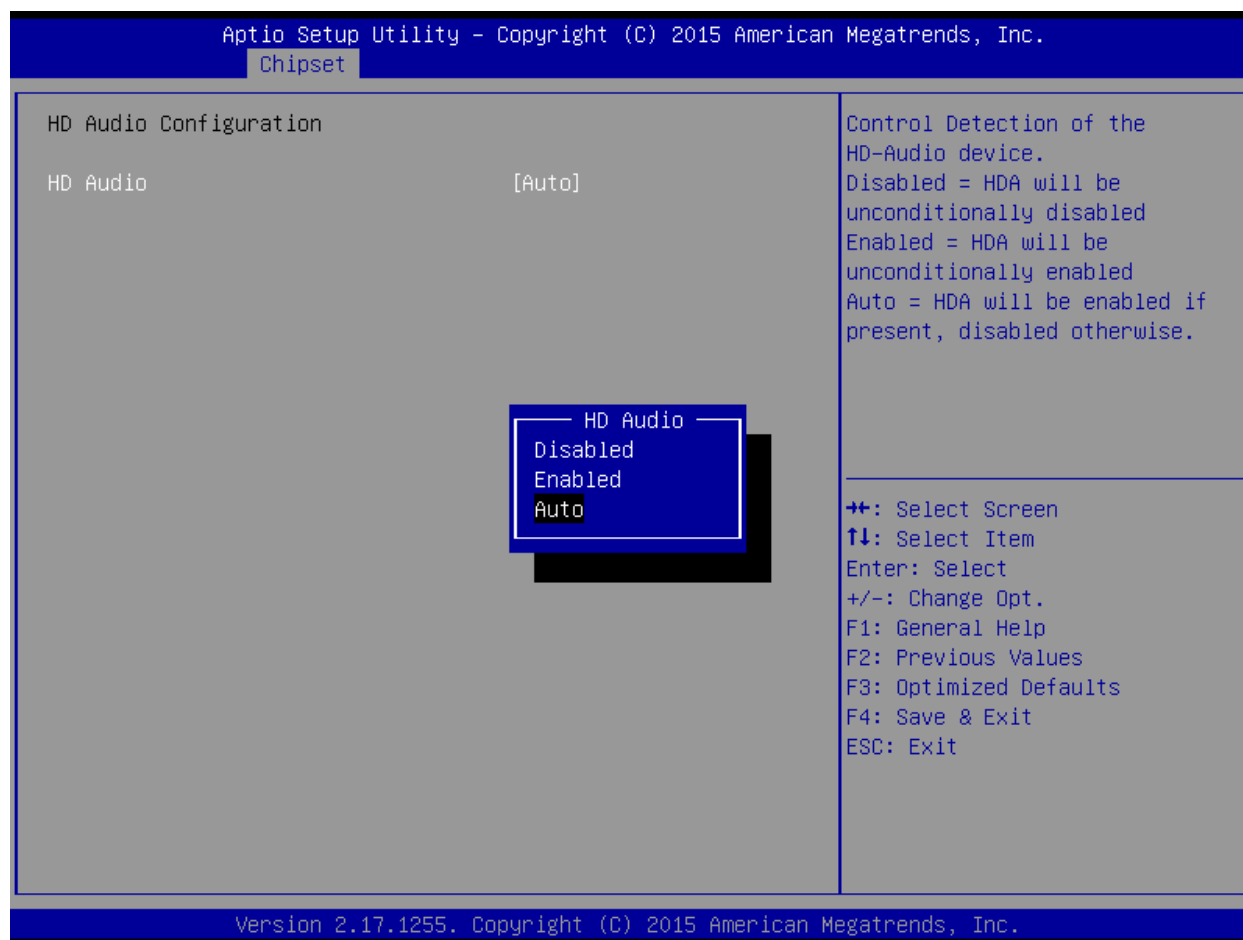

- **HD audio[Auto]**
Control Detection of the HD-Audio device.
Configuration options: [Disabled] [Enabled][Auto]

2.6 Security

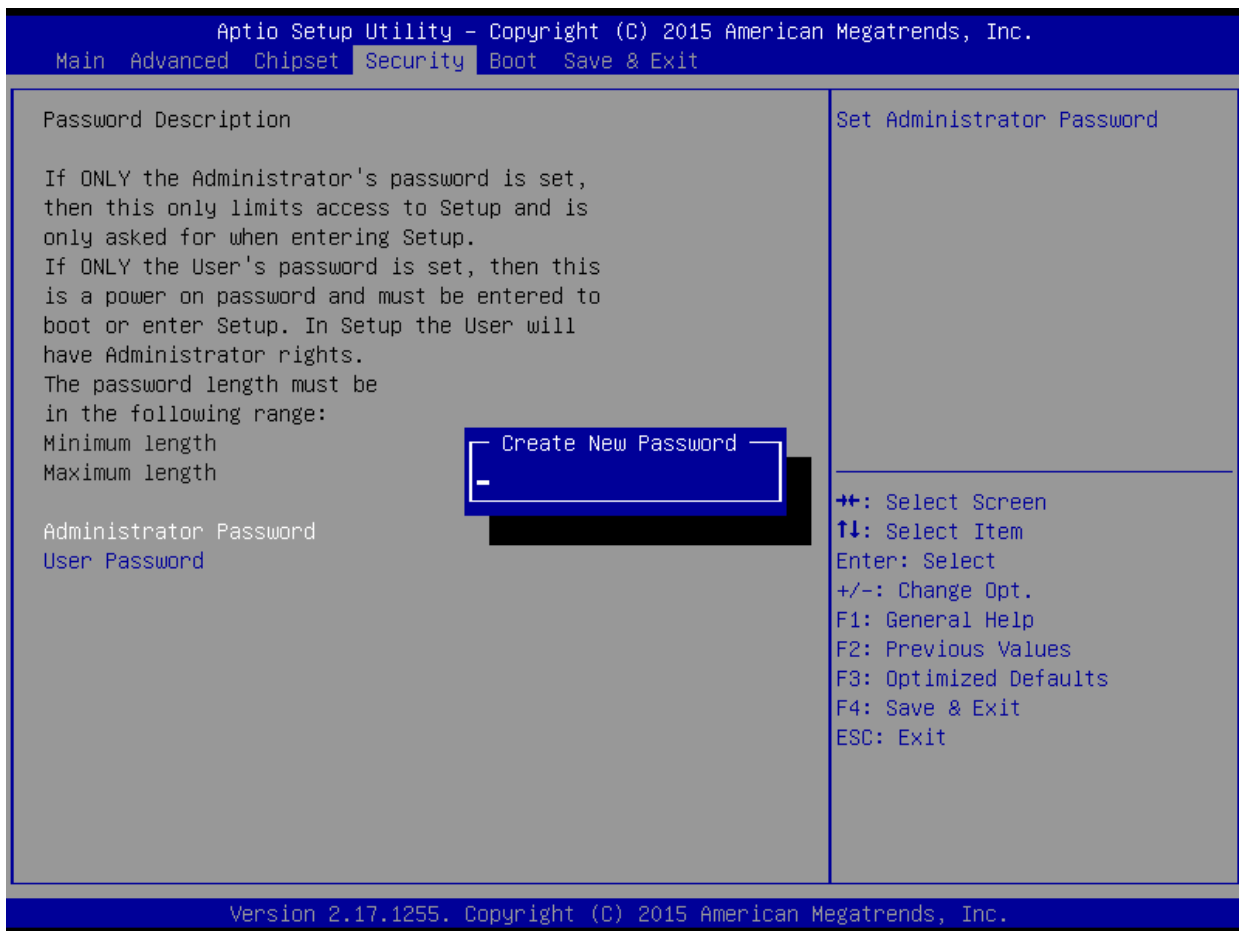

- **Administrator Password**
Set setup Administrator Password
- **User Password**
Set User Password

2.7 Boot

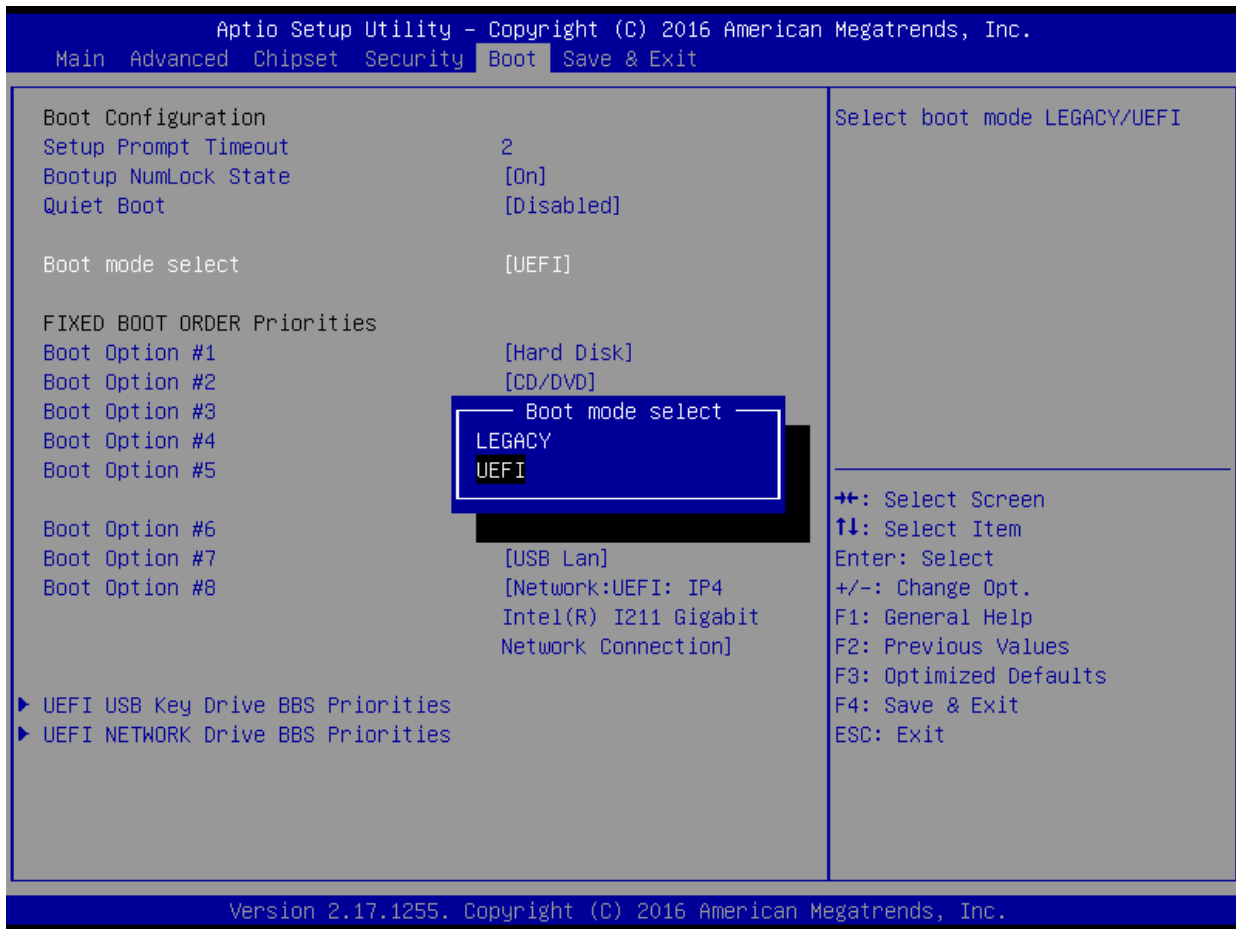

- **Setup Prompt Timeout [1]**
Number of seconds to wait for setup activation key. 65535(0xFFFF) means indefinite waiting.
- **Bootup NumLock State [On]**
Select the keyboard NumLock state
Configuration options: [On] [Off]
- **Quick Boot [Disable]**
Enable or disable Quick Boot option
Configuration options: [Disabled] [Enabled]
- **Boot mode select [UEFI]**
Select boot mode LEGACY/UEFI
Configuration options: [LEGACY] [UEFI]
- **UEFI USB Key Drive BBS Priorities**
Specifies the boot device priority sequence from available UEFI USB key Drives.
- **UEFI Network Key Drive BBS Priorities**
Specifies the boot device priority sequence from available UEFI Network key Drives.

2.8 Save & Exit

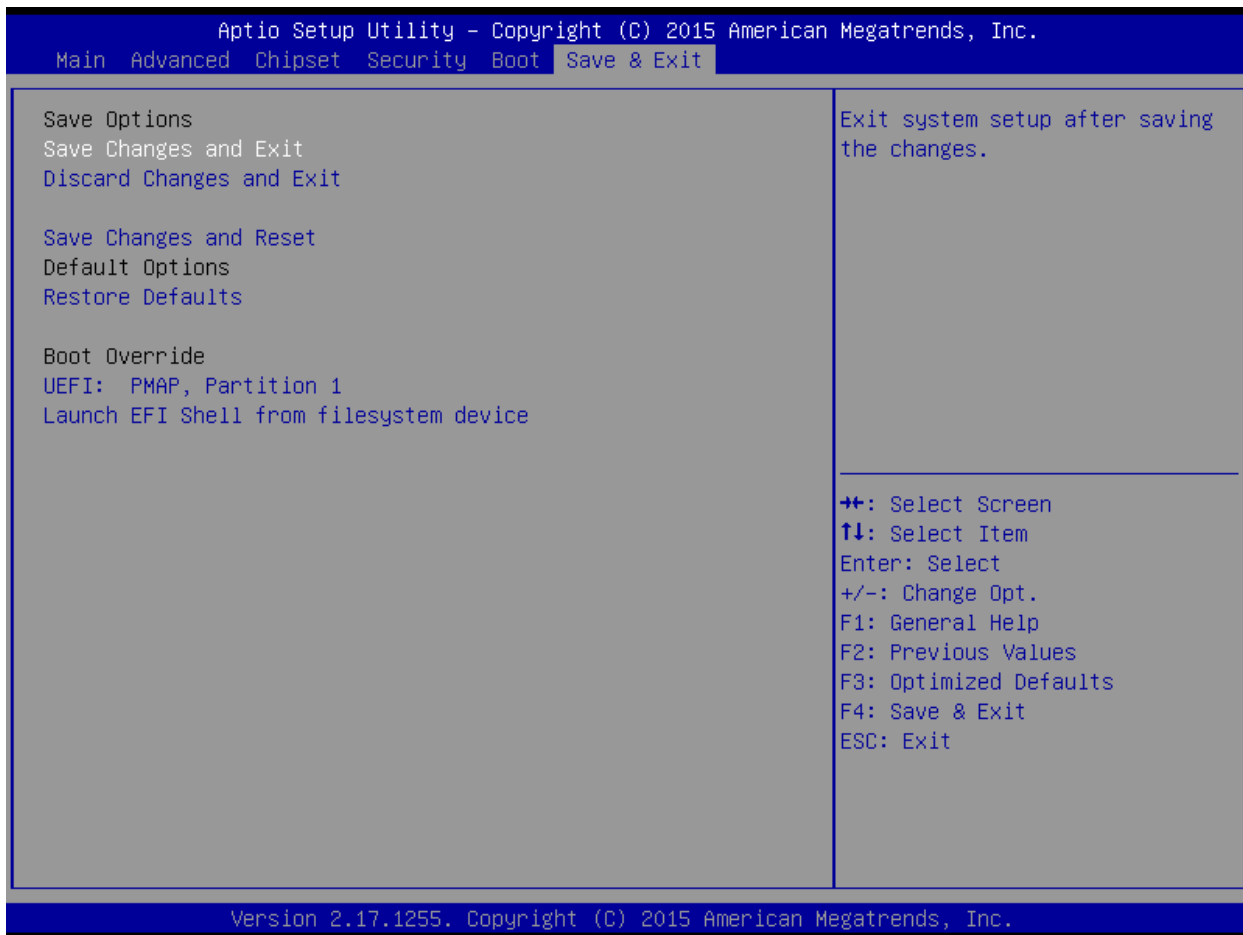

- **Save changes and Exit**
Exit system setup after saving the changes.
- **Discard changes and Exit**
Exit system setup without saving the changes.
- **Save changes and Reset**
Reset the system after saving the changes.
- **Restore Defaults**
Restore/Load default values for all the setup option.
- **Launch EFI Shell from filesystem device**
Attempts to launch EFI shell application from one of the available filesystem devices.

Appendix

Multi-Stream Transport Display Resolution

Technology	Multi-Stream Transport Display	Max Resolution	Pixel Clock [MHz]	Single Display Bandwidth [Gbps]	Bandwidth for all displays [Gbps]
H/S- Processor line	One panel Display	4096x2304@60Hz	605.00	18.15	18.15
	Two panel Display concurrently	2880x1800@60Hz	337.75	10.13	20.26
	Three panel Display concurrently ¹	2304x1440@60Hz	218.75	6.56	19.69

Notes:

1. Other ports are not available.
2. Same panels display resolution.
3. Per one display.
4. Total BW for all Display must be lower than the Max theoretical BW which is $5.4 \times 4 = 21.6$ [Gbps].
5. Additional cooling is required. Please refer [Table 2-27](#).

- The processor support only 3 streaming independent and simultaneous display combination of DisplayPort

RX170Q (#71163)

- Intel provides Windows 10 or later graphics driver only for MS Windows support, Skylake processor will continue to support previous version of Microsoft OS such as MS Windows 8.1/ 7.
- RX170Q require to use ME drive 11.6.0.1039 or later for Intel Kabylake processor.