

M.2 (S80)

3IE4 Series

Customer: _____
Customer
Part
Number: _____
Innodisk
Part
Number: _____
Innodisk
Model Name: _____
Date: _____

Innodisk Approver	Customer Approver

**Total Solution For
Industrial Flash Storage**

Table of contents

LIST OF FIGURES	6
1. PRODUCT OVERVIEW	7
1.1 INTRODUCTION OF INNODISK M.2 (S80) 3IE4	7
1.2 PRODUCT VIEW AND MODELS	7
1.3 SATA INTERFACE	7
2. PRODUCT SPECIFICATIONS	8
2.1 CAPACITY AND DEVICE PARAMETERS	8
2.2 PERFORMANCE	8
2.3 ELECTRICAL SPECIFICATIONS	8
2.3.1 Power Requirement	8
2.3.2 Power Consumption	9
2.4 ENVIRONMENTAL SPECIFICATIONS	9
2.4.1 Temperature Ranges	9
2.4.2 Humidity	9
2.4.3 Shock and Vibration	9
2.4.4 Mean Time between Failures (MTBF)	9
2.5 CE AND FCC COMPATIBILITY	10
2.6 RoHS COMPLIANCE	10
2.7 RELIABILITY	10
2.8 TRANSFER MODE	10
2.9 PIN ASSIGNMENT	11
2.10 MECHANICAL DIMENSIONS	13
2.11 ASSEMBLY WEIGHT	14
2.12 SEEK TIME	14
2.13 HOT PLUG	14
2.14 NAND FLASH MEMORY	14
3. THEORY OF OPERATION	15
3.1 OVERVIEW	15
3.2 SATA III CONTROLLER	15
3.3 ERROR DETECTION AND CORRECTION	15
3.4 WEAR-LEVELING	16
3.5 BAD BLOCKS MANAGEMENT	16
3.6 POWER CYCLING	16
3.7 GARBAGE COLLECTION	16
4. INSTALLATION REQUIREMENTS	17
4.1 M.2 (S80) 3IE4 PIN DIRECTIONS	17

4.2 ELECTRICAL CONNECTIONS FOR M.2 (S80) 3IE4	17
4.3 DEVICE DRIVE	17
5. SMART FEATURE SET	18
5.1 SMART ATTRIBUTES	18
6. PART NUMBER RULE	20
6. APPENDIX	21

REVISION HISTORY

Revision	Description	Date
Rev 1.0	Official Released	Jul., 2017
Rev 1.1	Update power consumption/RoHS certificate	Sep., 2017
Rev 1.2	TBW typo edited.	Feb., 2019

List of Tables

TABLE 1: DEVICE PARAMETERS	8
TABLE 2: PERFORMANCE	8
TABLE 3: INNODISK M.2 (S80) 3IE4 POWER REQUIREMENT	8
TABLE 4: POWER CONSUMPTION	9
TABLE 5: TEMPERATURE RANGE FOR M.2 (S80) 3IE4	9
TABLE 6: SHOCK/VIBRATION TESTING FOR M.2 (S80) 3IE4	9
TABLE 7: M.2 (S80) 3IE4 MTBF	10
TABLE 8: M.2 (S80) 3IE4 TBW	10
TABLE 9: INNODISK M.2 (S80) 3IE4 PIN ASSIGNMENT	11
TABLE 10: SMART COMMAND	18
TABLE 11: SMART ATTRIBUTE	18

List of Figures

FIGURE 1: INNODISK M.2 (S80) 3IE4 (TYPE 2280)	7
FIGURE 2: INNODISK M.2 (S80) 3IE4 DIAGRAM	13
FIGURE 3: INNODISK M.2 (S80) 3IE4 BLOCK DIAGRAM	15
FIGURE 4: SIGNAL SEGMENT AND POWER SEGMENT	17

1. Product Overview

1.1 Introduction of Innodisk M.2 (S80) 3IE4

Innodisk M.2 (S80) 3IE4 is characterized by L³ architecture with the latest SATA III (6.0GHz) Marvell NAND controller. Innodisk's exclusive L³ architecture is L² architecture multiplied LDPC (Low Density Parity Check). L² (Long Life) architecture is a 4K mapping algorithm that reduces WAF and features a real-time wear leveling algorithm to provide high performance and prolong lifespan with exceptional reliability. Innodisk M.2 (S80) 3IE4 is designed for industrial field, and supports several standard features, including TRIM, NCQ, and S.M.A.R.T. In addition, Innodisk's exclusive industrial-oriented firmware provides a flexible customization service, making it perfect for a variety of industrial applications.

1.2 Product View and Models

Innodisk M.2 (S80) 3IE4 is available in follow capacities within MLC flash ICs.

[M.2 \(S80\) 3IE4 8GB](#)

[M.2 \(S80\) 3IE4 16GB](#)

[M.2 \(S80\) 3IE4 32GB](#)

[M.2 \(S80\) 3IE4 64GB](#)

[M.2 \(S80\) 3IE4 128GB](#)



Figure 1: Innodisk M.2 (S80) 3IE4 (type 2280)

1.3 SATA Interface

Innodisk M.2 (S80) 3IE4 supports SATA III interface, and compliant with SATA I and SATA II. SATA III interface can work with Serial Attached SCSI (SAS) host system, which is used in server computer. Innodisk M.2 (S80) 3IE4 is compliant with Serial ATA Gen 1, Gen 2 and Gen 3 specification (Gen 3 supports 1.5Gbps /3.0Gbps/6.0Gbps data rate).

2. Product Specifications

2.1 Capacity and Device Parameters

M.2 (S80) 3IE4 device parameters are shown in Table 1.

Table 1: Device parameters

Capacity	Cylinders	Heads	Sectors	LBA	User Capacity(MB)
8GB	15525	16	63	15649200	7,641
16GB	16383	16	63	31277232	15,272
32GB	16383	16	63	62533296	30,533
64GB	16383	16	63	125045424	61,057
128GB	16383	16	63	250069680	122,104

2.2 Performance

Burst Transfer Rate: 6.0Gbps

Table 2: Performance

Capacity	8GB		16GB	32GB	64GB	128GB
	1CH	2CH				
Sequential* Read (max.)	250 MB/s	290 MB/s	500MB/s	530 MB/s	530 MB/s	530 MB/s
Sequential* Write (max.)	80 MB/s	200 MB/s	160 MB/s	300 MB/s	360 MB/s	360 MB/s
4KB Random* Read (QD32)	12000 IOPS	18000 IOPS	23000 IOPS	30000 IOPS	31000 IOPS	31000 IOPS
4KB Random* Write (QD32)	12000 IOPS	27000 IOPS	27000 IOPS	30000 IOPS	31000 IOPS	31000 IOPS

Note: * Performance is based on CrystalDiskMark 5.1.2 with file size 1000MB of Queue Depth 32

2.3 Electrical Specifications

2.3.1 Power Requirement

Table 3: Innodisk M.2 (S80) 3IE4 Power Requirement

Item	Symbol	Rating	Unit
Input voltage	V _{IN}	+3.3 DC +- 5%	V

2.3.2 Power Consumption

Table 4: Power Consumption

Mode	Power Consumption (mA)
Startup	710 (max.)
Read	355 (max.)
Write	370 (max.)
Idle	130 (max.)

* Target: 128GB M.2 (S80) 3IE4

2.4 Environmental Specifications

2.4.1 Temperature Ranges

Table 5: Temperature range for M.2 (S80) 3IE4

Temperature	Range
Operating	Standard Grade: 0°C to +70°C
	Industrial Grade: -40°C to +85°C
Storage	-55°C to +95°C

2.4.2 Humidity

Relative Humidity: 10-95%, non-condensing

2.4.3 Shock and Vibration

Table 6: Shock/Vibration Testing for M.2 (S80) 3IE4

Reliability	Test Conditions	Reference Standards
Vibration	7 Hz to 2K Hz, 20G, 3 axes	IEC 68-2-6
Mechanical Shock	Duration: 0.5ms, 1500 G, 3 axes	IEC 68-2-27

2.4.4 Mean Time between Failures (MTBF)

Table 7 summarizes the MTBF prediction results for various M.2 (S80) 3IE4 configurations. The analysis was performed using a RAM Commander™ failure rate prediction.

- **Failure Rate:** The total number of failures within an item population, divided by the total number of life units expended by that population, during a particular measurement interval under stated condition.
- **Mean Time between Failures (MTBF):** A basic measure of reliability for repairable items: The mean number of life units during which all parts of the item perform within their specified limits, during a particular measurement interval under stated conditions.
-

Table 7: M.2 (S80) 3IE4 MTBF

Product	Condition	MTBF (Hours)
Innodisk M.2 (S80) 3IE4	Telcordia SR-332 GB, 25°C	>3,000,000

2.5 CE and FCC Compatibility

M.2 (S80) 3IE4 conforms to CE and FCC requirements.

2.6 RoHS Compliance

M.2 (S80) 3IE4 is fully compliant with RoHS directive.

2.7 Reliability

Table 8: M.2 (S80) 3IE4 TBW

Parameter		Value
Read Cycles		Unlimited Read Cycles
Flash endurance		20,000 P/E cycles
Wear-Leveling Algorithm		Support
Bad Blocks Management		Support
Error Correct Code		Support
TBW* (Total Bytes Written) Unit: TB		
Capacity	Sequential workload	Client workload
8GB	156.25	104.2
16GB	312.5	208.3
32GB	625.0	416.7
64GB	1250.0	833.3
128GB	2500.0	1388.9
* Note:		
1. Sequential: Mainly sequential write, tested by Vdbench.		
2. Client: Follow JESD218 Test method and JESD219A Workload, tested by ULINK. (The capacity lower than 64GB client workload is not specified in JEDEC219A, the values are estimated.)		
3. Based on out-of-box performance.		

2.8 Transfer Mode

M.2 (S80) 3IE4 support following transfer mode:

Serial ATA III 6.0Gbps

Serial ATA II 3.0Gbps

Serial ATA I 1.5Gbps

2.9 Pin Assignment

Innodisk M.2 (S80) 3IE4 uses a standard SATA pin-out. See Table 9 for M.2 (S80) 3IE4 pin assignment.

Table 9: Innodisk M.2 (S80) 3IE4 Pin Assignment

Signal Name	Pin #	Pin #	Signal Name
		75	GND
3.3V	74	73	GND
3.3V	72	71	GND
3.3V	70	69	GND
NC	68	67	NC
Notch	66	65	Notch
Notch	64	63	Notch
Notch	62	61	Notch
Notch	60	59	Notch
NC	58		
NC	56	57	GND
NC	54	55	NC
NC	52	53	NC
NC	50	51	GND
NC	48	49	RX+
NC	46	47	RX-
NC	44	45	GND
NC	42	43	TX-
NC	40	41	TX+
DEVSLP	38	39	GND
NC	36	37	NC
NC	34	35	NC
NC	32	33	GND
NC	30	31	NC
NC	28	29	NC
NC	26	27	GND
NC	24	25	NC
NC	22	23	NC
NC	20	21	GND
Notch	18	19	Notch
Notch	16	17	Notch
Notch	14	15	Notch
Notch	12	13	Notch

DAS/DSS	10	11	NC
NC	8	9	NC
NC	6	7	NC
3.3V	4	5	NC
3.3V	2	3	GND
		1	GND

2.10 Mechanical Dimensions

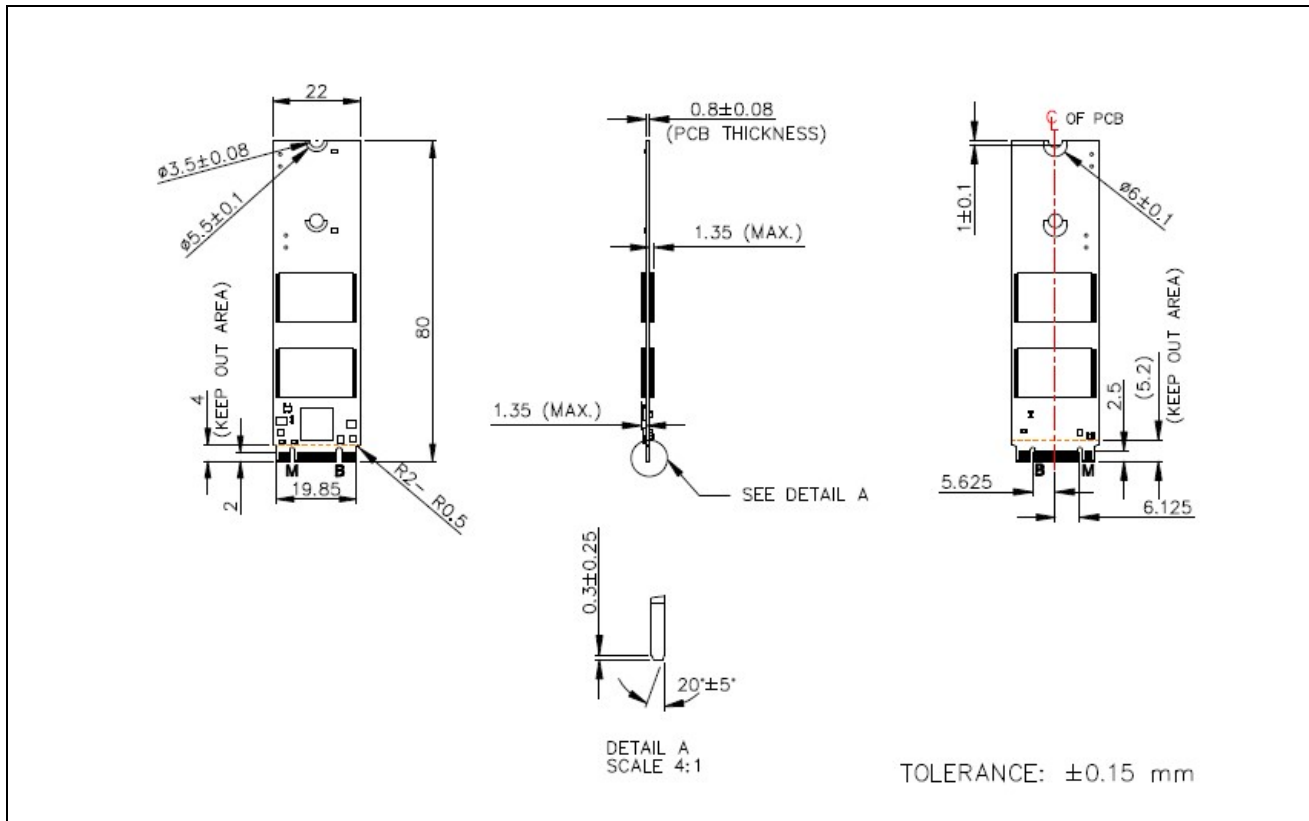

Figure 2: Innodisk M.2 (S80) 3IE4 diagram

2.11 Assembly Weight

An Innodisk M.2 (S80) 3IE4 within flash ICs, 64GB's weight is 8 grams approximately.

2.12 Seek Time

Innodisk M.2 (S80) 3IE4 is not a magnetic rotating design. There is no seek or rotational latency required.

2.13 Hot Plug

The SSD support hot plug function and can be removed or plugged-in during operation. User has to avoid hot plugging the SSD which is configured as boot device and installed operation system.

Surprise hot plug : The insertion of a SATA device into a backplane (combine signal and power) that has power present. The device powers up and initiates an OOB sequence.

Surprise hot removal: The removal of a SATA device from a powered backplane, without first being placed in a quiescent state.

2.14 NAND Flash Memory

Innodisk M.2 (S80) 3IE4 uses Multi Level Cell (MLC) NAND flash memory, which is non-volatility, high reliability and high speed memory storage.

3. Theory of Operation

3.1 Overview

Figure 2 shows the operation of Innodisk M.2 (S80) 3IE4 from the system level, including the major hardware blocks.

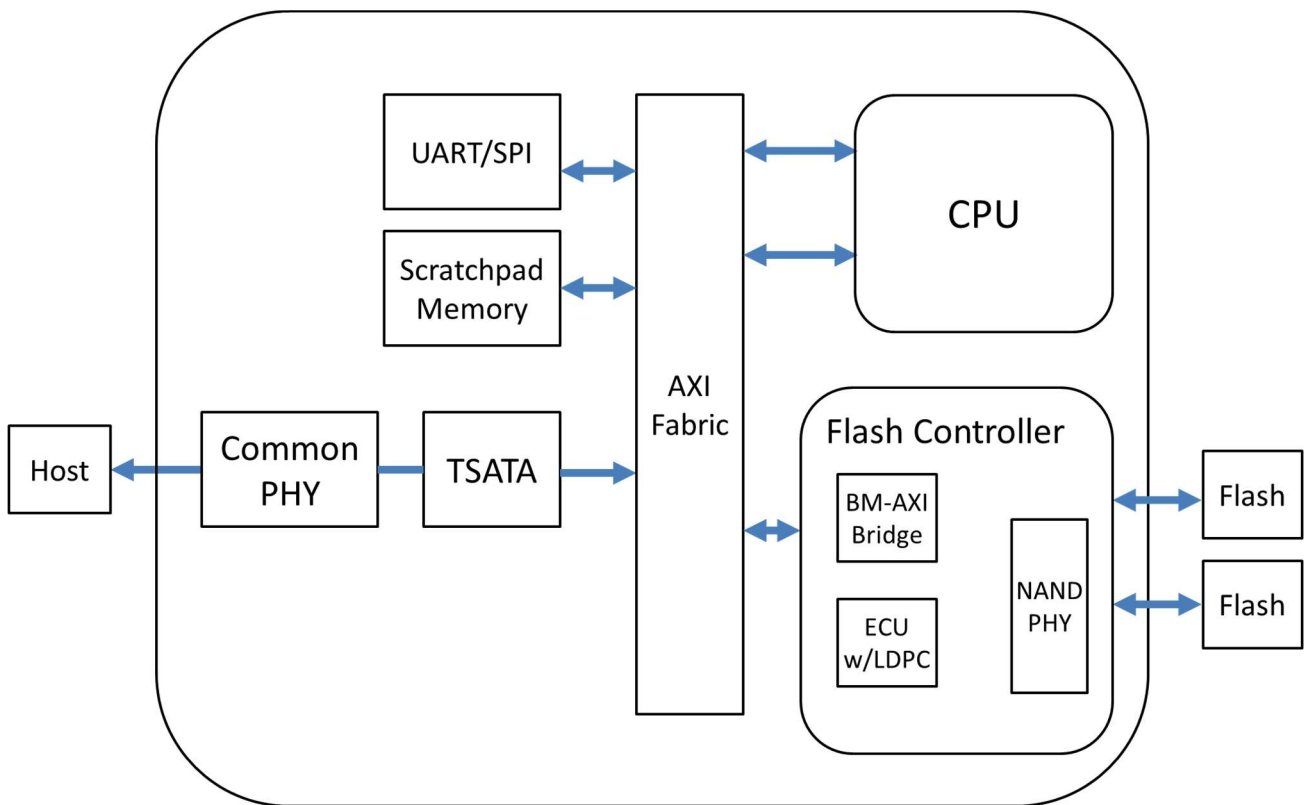

Figure 3: Innodisk M.2 (S80) 3IE4 Block Diagram

Innodisk M.2 (S80) 3IE4 integrates a SATA III controller and NAND flash memories. Communication with the host occurs through the host interface, using the standard ATA protocol. Communication with the flash device(s) occurs through the flash interface.

3.2 SATA III Controller

Innodisk M.2 (S80) 3IE4 is designed with 88NV1120, a SATA III 6.0Gbps (Gen. 3) controller. The Serial ATA physical, link and transport layers are compliant with Serial ATA Gen 1, Gen 2 and Gen 3 specification (Gen 3 supports 1.5Gbps/3.0Gbps/6.0Gbps data rate). The controller has 2 channels for flash interface.

3.3 Error Detection and Correction

Innodisk 2.5" SATA SSD 3IE4 is designed with hardware LDPC ECC engine with hard-decision and soft-decision decoding. Low-density parity-check (LDPC) codes have excellent error correcting

performance close to the Shannon limit when decoded with the belief-propagation (BP) algorithm using soft-decision information.

3.4 Wear-Leveling

Flash memory can be erased within a limited number of times. This number is called the **erase cycle limit** or **write endurance limit** and is defined by the flash array vendor. The erase cycle limit applies to each individual erase block in the flash device.

Innodisk M.2 (S80) 3IE4 uses a static wear-leveling algorithm to ensure that consecutive writes of a specific sector are not written physically to the same page/block in the flash. This spreads flash media usage evenly across all pages, thereby extending flash lifetime.

3.5 Bad Blocks Management

Bad Blocks are blocks that contain one or more invalid bits whose reliability are not guaranteed. The Bad Blocks may be presented while the SSD is shipped, or may develop during the life time of the SSD. When the Bad Blocks is detected, it will be flagged, and not be used anymore. The SSD implement Bad Blocks management, Bad Blocks replacement, Error Correct Code to avoid data error occurred. The functions will be enabled automatically to transfer data from Bad Blocks to spare blocks, and correct error bit.

3.6 Power Cycling

Innodisk's power cycling management is a comprehensive data protection mechanism that functions before and after a sudden power outage to SSD. Low-power detection terminates data writing before an abnormal power-off, while table-remapping after power-on deletes corrupt data and maintains data integrity. Innodisk's power cycling provides effective power cycling management, preventing data stored in flash from degrading with use.

3.7 Garbage Collection

Garbage collection is used to maintain data consistency and perform continual data cleansing on SSDs. It runs as a background process, freeing up valuable controller resources while sorting good data into available blocks, and deleting bad blocks. It also significantly reduces write operations to the drive, thereby increasing the SSD's speed and lifespan.

4. Installation Requirements

4.1 M.2 (S80) 3IE4 Pin Directions

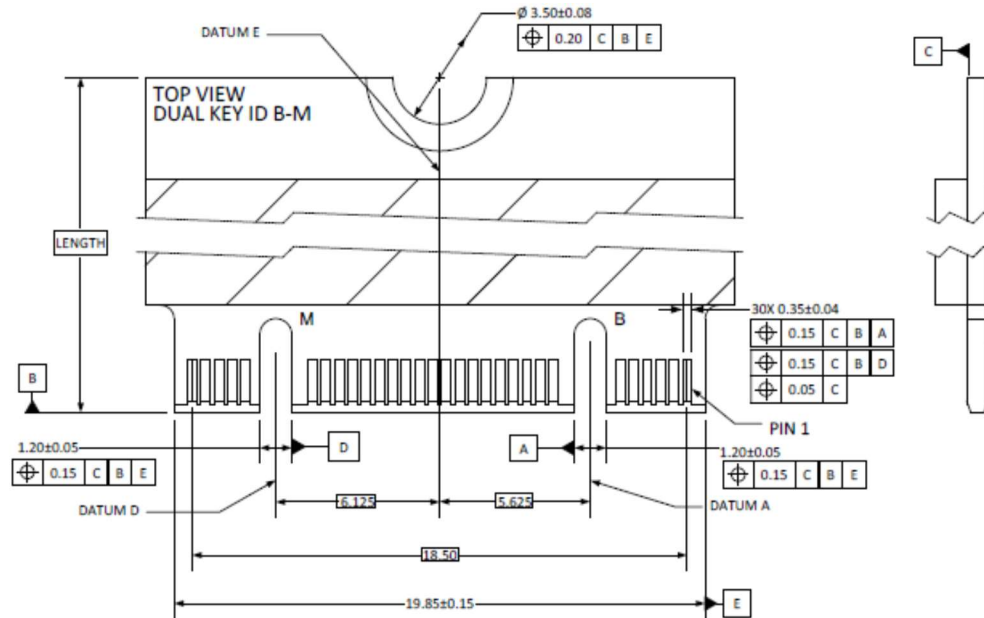

Figure 4: Signal Segment and Power Segment

4.2 Electrical Connections for M.2 (S80) 3IE4

A Serial ATA device may be either directly connected to a host or connected to a host through a cable. For connection via cable, the cable should be no longer than 1meter. The SATA interface has a separate connector for the power supply. Please refer to the pin description for further details.

4.3 Device Drive

No additional device drives are required. The Innodisk M.2 (S80) 3IE4 can be configured as a boot device.

5. SMART Feature Set

Innodisk 3ME4 series support the SMART command set and defines some vendor-specific data to report SMART attributes of SSD.

Table 10: SMART command

Value	Command	Value	Command
D0h	Read Data	D5h	Read Log
D1h	Read Attribute Threshold	D6h	Return Status
D2h	Enable/Disable Auto save	D8h	Enable SMART Operations
D3h	Save Attribute Values	D9h	Disable SMART Operations
D4h	Execute OFF-LINE Immediate	DAh	Return Status

5.1 SMART Attributes

Innodisk 3ME4 series SMART data attributes are listed in following table.

Table 11: SMART attribute

Attribute ID (hex)	Value	Raw Attribute Value						Rsv	Attribute Name
01	X								Read Error Rate
05	X	LSB	MSB	00	00	00	00	00	Later Bad
09	LSB	LSB	MSB	00	00	00	00	00	Power-On hours Count
0C	LSB	LSB	MSB	00	00	00	00	00	Drive Power Cycle Count
A3	X	LSB			MSB	00	00	00	Total Bad Block Count
A5	LSB	LSB			MSB	00	00	00	Max Erase count
A7	LSB	LSB			MSB	00	00	00	Avg Erase count
A9	LSB	LSB	00	00	00	00	00	00	Device Life
AA	X	LSB	MSB	00	00	00	00	00	Spare Block Count
AB	LSB	LSB	MSB	00	00	00	00	00	Program fail count
AC	LSB	LSB	MSB	00	00	00	00	00	Erase fail count
C0	LSB	LSB	MSB	00	00	00	00	00	Unexpected Power Loss Count

C2	LSB			MIN		MAX	00	00	Temperature
E5		ID 0	ID 1	ID 2	ID 3	ID 4	ID 5		Flash ID
EB			MSB	LSB	MSB	LSB	MSB	LSB	Later bad block info (Read/Write/Erase)
F1	00	LSB			MSB	00	00	00	Total LBA written(LBA=32MB)
F2	00	LSB			MSB	00	00	00	Total LBA read(LBA=32MB)

6. Part Number Rule

CODE	1	2	3	4	5	6	7	8	9	10	11	12	13	14	15	16	17	18	19	20	21
	D	H	M	2	8	-	6	4	G	M	4	1	B	C	1	D	C	-	X	X	X
Definition																					
Code 1st (Disk)											Code 14th (Operation Temperature)										
D : Disk											C: Standard Grade (0°C ~ +70°C)										
Code 2nd (Feature set)											W: Industrial Grade (-40°C ~ +85°C)										
H : Embedded series (iSLC)																					
Code 3rd ~5th (Form factor)											Code 15th (Internal control)										
M28: M.2 Type 2280-D2-B-M											1~9: TSOP PCB version.										
Code 7th ~9th (Capacity)											Code 16th (Channel of data transfer)										
08G: 8GB			16G: 16GB.			32G: 32GB					S: Single Channel										
64G: 64GB			A28: 128GB								D: Dual Channels										
Code 10th ~12th (Controller)											Code 17th (Flash Type)										
M41: 88NV1120											C: Toshiba MLC										
Code 13th (Flash mode)											Code 19th ~21st (Customize code)										
B: Synchronous NAND for Toshiba 15nm																					

6. Appendix

REACH

innodisk

宜鼎國際股份有限公司
Innodisk Corporation

Tel: (02) 7703-3000 Fax: (02) 7703-3555 Internet: <http://www.innodisk.com/>

REACH Declaration of Conformity

Manufacturer Product: All Innodisk EM Flash and Dram products

1. 宜鼎國際股份有限公司（以下稱本公司）特此保證此售予貴公司之產品，皆符合歐盟化學品法案(Registration, Evaluation and Authorization of Chemicals: (EC) No 1907/2006 REACH) 以及附錄 XIV 中的限用物質之規定 (<http://www.echa.europa.eu/de/candidate-list-table> last updated: 12/01/2017, SVHC's 173)。

所提供之產品包含：(1) 產品或產品所使用到的所有原物料；(2) 包裝材料；(3) 設計、生產及重工過程中所使用到的所有原物料。

We Innodisk Corporation hereby declare that our products are in compliance with the requirements according to the (EC) No 1907/2006 REACH Regulation and restricted substances in Annex XIV (<http://www.echa.europa.eu/de/candidate-list-table> last updated: 12/01/2017, SVHC's 173).

Products include: 1) Product and raw material used by the product; 2) Packaging material; 3) Raw material used in the process of design, production and rework.

2. 本公司同意因本保證書或與本保證書相關事宜有所爭議時，雙方宜友好協商，達成協議。InnoDisk Corporation agrees that both parties shall settle any dispute arising from or in connection with this Declaration of Conformity by friendly negotiations.

立保證書人 (Guarantor)

Company name 公司名稱：InnoDisk Corporation 宜鼎國際股份有限公司

Company Representative 公司代表人：Randy Chien 簡川勝

Company Representative Title 公司代表人職稱：Chairman 董事長

Date 日期：2017 / 02 / 08



RoHS



宜鼎國際股份有限公司
Innodisk Corporation

Tel:(02)7703-3000 Fax:(02) 7703-3555 Internet: <http://www.innodisk.com/>

RoHS 自我宣告書 (RoHS Declaration of Conformity)

Manufacturer Product: All Innodisk EM Flash and Dram products

- 一、 宜鼎國際股份有限公司 (以下稱本公司) 特此保證售予貴公司之所有產品，皆符合歐盟 2011/65/EU 及 (EU) 2015/863 關於 RoHS 之規範要求。
Innodisk Corporation declares that all products sold to the company, are complied with European Union RoHS Directive (2011/65/EU) and (EU) 2015/863 requirement.
- 二、 本公司同意因本保證書或與本保證書相關事宜有所爭議時，雙方宜友好協商，達成協議。
Innodisk Corporation agrees that both parties shall settle any dispute arising from or in connection with this Declaration of Conformity by friendly negotiations.

Name of hazardous substance	Limited of RoHS ppm (mg/kg)
鉛 (Pb)	< 1000 ppm
汞 (Hg)	< 1000 ppm
鎘 (Cd)	< 100 ppm
六價鉻 (Cr 6+)	< 1000 ppm
多溴聯苯 (PBBs)	< 1000 ppm
多溴二苯醚 (PBDEs)	< 1000 ppm
鄰苯二甲酸二(2-乙基己基)酯 (DEHP)	< 1000 ppm
鄰苯二甲酸丁酯苯甲酯 (BBP)	< 1000 ppm
鄰苯二甲酸二丁酯 (DBP)	< 1000 ppm
鄰苯二甲酸二異丁酯 (DIBP)	< 1000 ppm

立 保 證 書 人 (Guarantor)

Company name 公司名稱: Innodisk Corporation 宜鼎國際股份有限公司

Company Representative 公司代表人: Randy Chien 簡川勝

Company Representative Title 公司代表人職稱: Chairman 董事長

Date 日期: 2017 / 01 / 18



CE



VERIFICATION OF COMPLIANCE

This Verification of Compliance is hereby issued to the below named company. The test results of this report relate only to the tested sample identified in this report.

**Technical Standard: EMC DIRECTIVE 2014/30/EU
(EN55032 / EN55024)**

General Information
 Applicant: Innodisk Corporation
 5F., No. 237, Sec. 1, Datong Rd., Xizhi Dist.,
 New Taipei City 22161, Taiwan (R.O.C)

Product Description
 EUT Description: M.2
 Brand Name: Innodisk
 Model Number: M.2 (S80) 3S*0-&
 S:Flash type: (S:SLC, L:SLC, M:MLC, T:3D TLC, A-Z:Others);
 * Product line: (E:Embedded, G:EverGreen, R:InnoRobust, S:Server, V:InnoREC, A-Z:Others);
 † Product Generation: (empty, 0-9);
 & Product line: (empty, P:Plus)

Measurement Standard
 EN 55032: 2012 / AC: 2013
 CISPR 32: 2012
 EN 61000-3-2: 2014
 EN 61000-3-3: 2013
 EN 55024: 2010 + A1: 2013
 (IEC 61000-4-2: 2008; IEC 61000-4-3: 2008 + A1: 2007 + A1: 2010; IEC 61000-4-4: 2012;
 IEC 61000-4-5: 2014; IEC 61000-4-6: 2013; IEC 61000-4-8: 2009; IEC 61000-4-11: 2004)

Measurement Facilities
 Xindian Lab.: Compliance Certification Services Inc.
 No.163-1, Zhongsheng Rd., Xindian Dist., New Taipei City, 23151 Taiwan.
 Tel: +886-2-22170894 / Fax: +886-2-22171029

This device has been shown to be in compliance with and was tested in accordance with the measurement procedures specified in the Standards & Specifications listed above and as indicated in the measurement report number: T170504(D)5-E

 Sam Hsu / Assistant Manager
 Date: May 10, 2017



CCSRF
 綠盟科技股份有限公司
 Compliance Certification Services Inc.

FCC



VERIFICATION OF COMPLIANCE

This Verification of Compliance is hereby issued to the below named company. The test results of this report relate only to the tested sample identified in this report.

**Technical Standard: FCC Part 15 Class B
IC ICES-003**

General Information

Applicant: Innodisk Corporation
5F., No. 237, Sec. 1, Datong Rd., Xuzhi Dist.,
New Taipei City 22161, Taiwan (R.O.C)

Product Description

EUT Description: M.2
Brand Name: Innodisk
Model Number: M.2 (S80) 3S*0-&
S:Flash type: (S:SLC, I:SLC, M:MLC, T:3D TLC, A-Z:Others);
*Product line: (E:Embedded, G:EverGreen, R:InnoRobot, S:Server, V:InnoREC, A-Z:Others);
#Product Generation: (empty, 0-9);
&:Product line: (empty, P:Plus)

Measurement Facilities

Xindian Lab.: Compliance Certification Services Inc.
No. 163-1, Zhongsheng Rd., Xindian Dist., New Taipei City, 23151 Taiwan.
Tel: +886-2-22170894 / Fax: +886-2-22171029

This device has been shown to be in compliance with and was tested in accordance with the measurement procedures specified in the Standards & Specifications listed above and as indicated in the measurement report number: T170504D05-D

Sam Hsu / Assistant Manager

Date: May 10, 2017

