

Apacer

The Most **Reliable**
Storage For Industries

SH250-300B



SH250-300B

Overview

Apacer's SH250-300B, utilizing 3D NAND for higher capacity up to 320GB and providing more power efficiency than 2D NAND, is the next generation Solid State Drive (SSD) with compact and high-speed storage and great performance. Designed in SATA 6 Gb/s interface, SH250-300B provides full compliance with the latest SATA Revision 3.2 interface specifications and delivers exceptional read/write speed, making it the leading add-in storage solution for future host computing systems.



SH250-300B is built with a powerful SATA controller that supports on-the-module ECC as well as efficient wear leveling scheme and implemented with LDPC (Low Density Parity Check) ECC engine to extend SSD endurance and increase data reliability. With Apacer's SLC-liteX technology, SH250-300B performs with higher number of P/E cycles up to 100,000 times. Furthermore, SH250-300B is equipped with a built-in thermal sensor to monitor the temperature of the SSD via S.M.A.R.T commands to prevent overheating. Operating under 6 Gb/s interface, SH250-300B is provided with Apacer latest S.M.A.R.T. that is primarily oriented for the latest SATA interface SSD, for drive lifetime monitoring and analysis. For highly-intensive applications, End-to-End Data Protection ensures that data integrity can be assured at multiple points in the path to enable reliable delivery of data transfers.

Security-wise, Advanced Encryption Standard (AES) ensures data security and provides users with peace of mind knowing their data is safeguarded at all times. SH250-300B also adopts the latest page mapping file translation layer and comes with various implementations including power saving modes, wear leveling, flash block management, S.M.A.R.T., TRIM, DataDefender™ and SMART Read Refresh™. With exceptional performance, trustable reliability and enhanced data protection, SH250-300B is definitely the ideal storage or cache solution for a variety of applications ranging from industrial, imaging, computing to enterprise markets.

SH250-300B

Feature

- Low-Density Parity-Check (LDPC) Code
- Global Wear Leveling
- Flash bad-block management
- Flash Translation Layer: Page Mapping
- S.M.A.R.T. Function
- DataDefender™
- Device Sleep
- ATA Secure Erase
- TRIM Support
- SMART Read Refresh™
- SLC-liteX (P/E cycle: 100K)

Specifications

Model	SH250-300B
Interface	SATA 3.2 (6Gb/s)
Connector	52-pin mSATA connector
Form Factor	mSATA mini, JEDEC MO-300B
NAND Flash Type	3D TLC
Capacity	40GB~320GB
External DRAM	No
Sustained Read Performance (MB/sec)	Up to 550
Sustained Write Performance (MB/sec)	Up to 485
ECC Engine	Low-Density Parity-Check (LDPC) Code
IOPS (4K Random Write)	63K
Standard Operating Temperature (°C)	0 ~ + 70
Extended Operating Temperature (°C)	-40 ~ + 85
Storage Temperature (°C)	-55 ~ + 100
Thermal Sensor	Yes
Shock	Operation: 50G/11ms (compliant with MIL-STD-202G) Non-operation: 1500G/0.5ms (compliant with MIL-STD-883K)
Vibration	Operation: 7.69 Grms, 20~2000 Hz/random (compliant with MIL-STD-810G) Non-operation: 4.02 Grms, 15 ~ 2000 Hz/random (compliant with MIL-STD-810G)
Operating Voltage	3.3 V ±5%
Power Consumption	Active mode: 410 mA / Idle mode: 60 mA
Dimension (L x W x H)	29.85 x 26.80 x 3.85 mm
MTBF (hours)	>3,000,000

Mechanical Specification

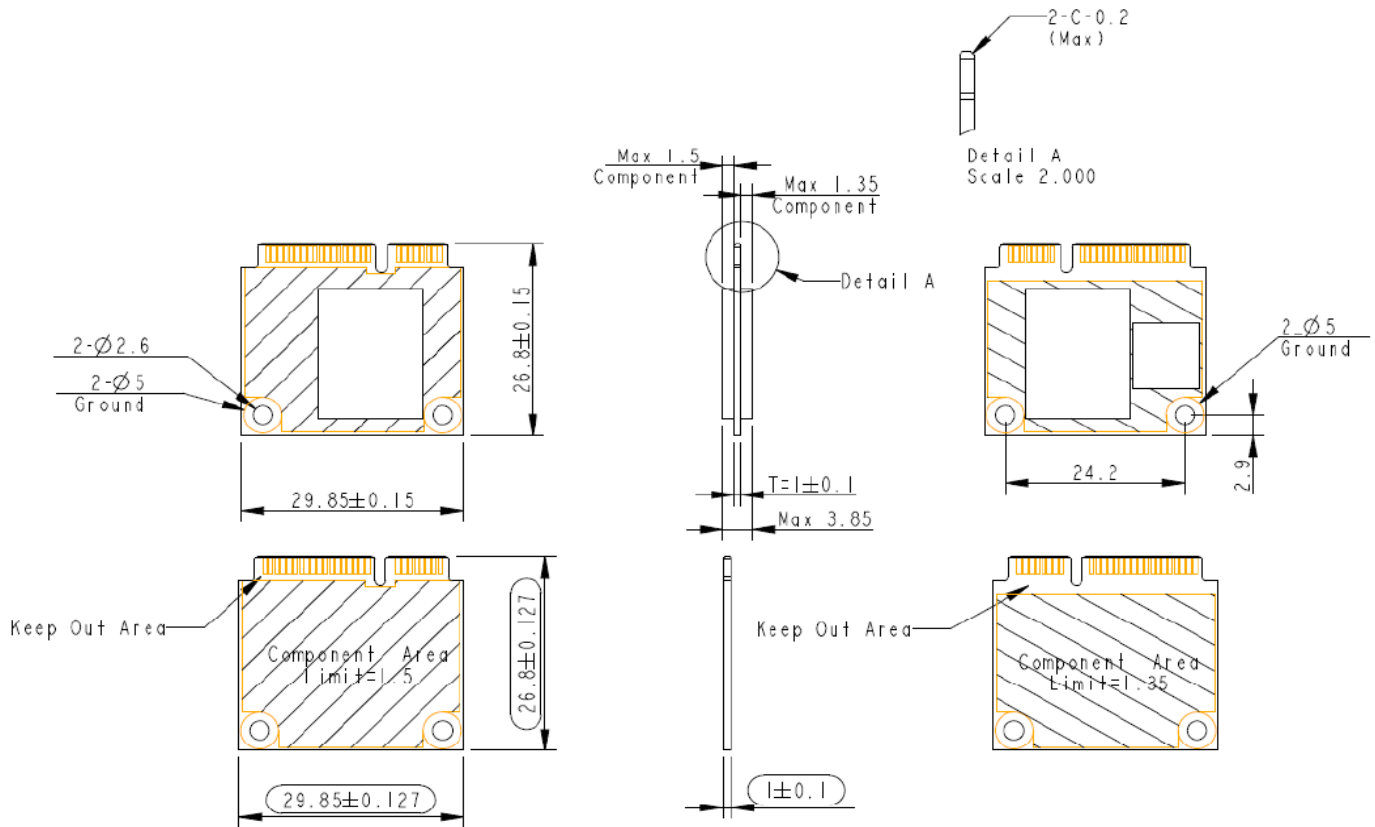

Unit: mm

For more information,
contact your Apacer representative

Global Presence

Taiwan (Headquarters)
Apacer Technology Inc.
Tel: +886-2-2267-8000
Fax: +886-2-2267-2261

Europe
Apacer Technology B.V.
Tel: +31-40-267-0000
Fax: +31-40-290-0686

U.S.A.
Apacer Memory America, Inc.
Tel: +1-408-518-8699
Fax: 1-510-249-9551

Shanghai
Apacer Electronic(Shanghai)
Co., Ltd.
Tel: +86-21-6228-9939

Japan
Apacer Technology Corp.
Tel: +81-3-5419-2668
Fax: +81-3-5419-0018

India
Apacer Technologies Pvt. Ltd.
Tel: +91-80-41529061~3
Fax: +91-80-41700215