

# M.2 (P80)

## 3TE6 Series

with AES function

**Customer:** \_\_\_\_\_

**Customer**

**Part**

**Number:** \_\_\_\_\_

**Innodisk**

**Part**

**Number:** \_\_\_\_\_

**Innodisk**

**Model**

**Name:** \_\_\_\_\_

**Date:** \_\_\_\_\_

<b>Innodisk Approver</b>	<b>Customer Approver</b>

## Features:

- PCIe Gen.3 x 4, NVMe SSD
- Kioxia 3D TLC NAND
- M.2 2280-S2-M Single-sided placement
- Wide-temperature for 112 Layers NAND
- With iPowerguard Design
- With iDataguard Design
- Dynamic Thermal Management
- Hybrid Write Mode with SLC Cache Enable
- AES-256 Bits Encryption Optional, Default disable
- Write Protect Optional, Default enable
- Quick Erase Optional, Default disable

## Performance:

- Sequential Read up to 2,050 MB/s
- Sequential Write up to 1,850 MB/s

## Power Requirements:

Input Voltage:	3.3V±5%
Max Operating Wattage:	5.6W
Idle Wattage:	1.1W

## Reliability:

Capacity	TBW	DWPD
128GB	93	0.68
256GB	206	0.75
512GB	471	0.86
1TB	1086	1
2TB	2600	1.1

Data Retention	10 Years
Warranty	3 Years

For warranty details, please refer to:

[https://www.innodisk.com/en/support\\_and\\_service/warranty](https://www.innodisk.com/en/support_and_service/warranty)

## Table of contents

<b>LIST OF FIGURES .....</b>	<b>7</b>
<b>1. PRODUCT OVERVIEW .....</b>	<b>8</b>
<b>1.1 INTRODUCTION OF INNODISK M.2 (P80) 3TE6.....</b>	<b>8</b>
<b>1.2 PRODUCT VIEW AND MODELS .....</b>	<b>8</b>
<b>1.3 PCIe INTERFACE .....</b>	<b>8</b>
<b>2. PRODUCT SPECIFICATIONS.....</b>	<b>9</b>
<b>2.1 CAPACITY AND DEVICE PARAMETERS.....</b>	<b>9</b>
<b>2.2 PERFORMANCE .....</b>	<b>10</b>
<b>2.3 ELECTRICAL SPECIFICATIONS .....</b>	<b>11</b>
<b>2.3.1 Power Requirement.....</b>	<b>11</b>
<b>2.3.2 Power Consumption .....</b>	<b>11</b>
<b>2.4 ENVIRONMENTAL SPECIFICATIONS .....</b>	<b>11</b>
<b>2.4.1 Temperature Ranges .....</b>	<b>11</b>
<b>2.4.2 Humidity.....</b>	<b>11</b>
<b>2.4.3 Shock and Vibration .....</b>	<b>11</b>
<b>2.4.4 Mean Time between Failures (MTBF) .....</b>	<b>12</b>
<b>2.5 CE AND FCC COMPATIBILITY .....</b>	<b>12</b>
<b>2.6 RoHS COMPLIANCE .....</b>	<b>12</b>
<b>2.7 RELIABILITY .....</b>	<b>13</b>
<b>2.8 TRANSFER MODE .....</b>	<b>13</b>
<b>2.9 PIN ASSIGNMENT .....</b>	<b>14</b>
<b>2.10 MECHANICAL DIMENSIONS.....</b>	<b>16</b>
<b>2.11 ASSEMBLY WEIGHT .....</b>	<b>16</b>
<b>2.12 SEEK TIME .....</b>	<b>16</b>
<b>2.13 NAND FLASH MEMORY.....</b>	<b>16</b>
<b>2.14 HEAT-SPREADING COPPER LAYER.....</b>	<b>16</b>
<b>3. THEORY OF OPERATION .....</b>	<b>17</b>
<b>3.1 OVERVIEW.....</b>	<b>17</b>
<b>3.2 PCIe GEN III x 4 CONTROLLER.....</b>	<b>17</b>
<b>3.3 ERROR DETECTION AND CORRECTION.....</b>	<b>18</b>
<b>3.4 WEAR-LEVELING .....</b>	<b>18</b>
<b>3.5 BAD BLOCKS MANAGEMENT .....</b>	<b>18</b>
<b>3.6 GARBAGE COLLECTION/TRIM .....</b>	<b>18</b>
<b>3.7 END TO END DATA PATH PROTECTION .....</b>	<b>18</b>
<b>3.8 THERMAL MANAGEMENT .....</b>	<b>19</b>
<b>3.9 iDATAGUARD.....</b>	<b>19</b>
<b>3.10 AES FUNCTION .....</b>	<b>19</b>

- 3.11 TCG OPAL..... 19**
- 4. INSTALLATION REQUIREMENTS ..... 20**
  - 4.1 M.2 (P80) 3TE6 PIN DIRECTIONS.....20**
  - 4.2 ELECTRICAL CONNECTIONS FOR M.2 (P80) 3TE6 .....20**
  - 4.3 DEVICE DRIVE .....20**
- 5. SMART / HEALTH INFORMATION..... 21**
  - 5.1 GET LOG PAGE(LOG IDENTIFIER 02H) .....21**
- 6. PART NUMBER RULE ..... 26**

## REVISION HISTORY

Revision	Description	Date
1.0	First release	Sep., 2023

## List of Tables

<b>TABLE 1: DEVICE PARAMETERS</b> .....	9
<b>TABLE 2: PERFORMANCE –112 LAYERS 3D TLC*</b> .....	10
<b>TABLE 3: INNODISK M.2 (P80) 3TE6 POWER REQUIREMENT</b> .....	11
<b>TABLE 4: 112 LAYERS 3D TLC</b> .....	11
<b>TABLE 5: TEMPERATURE RANGE FOR M.2 (P80) 3TE6</b> .....	11
<b>TABLE 6: SHOCK/VIBRATION TESTING FOR M.2 (P80) 3TE6</b> .....	11
<b>TABLE 7: M.2 (P80) 3TE6 MTBF</b> .....	12
<b>TABLE 8: M.2 (P80) 3TE6 TBW</b> .....	13
<b>TABLE 9: INNODISK M.2 (P80) 3TE6 PIN ASSIGNMENT</b> .....	14
<b>TABLE 10: GET LOG PAGE – SMART / HEALTH INFORMATION LOG</b> .....	21

## List of Figures

<b>FIGURE 1: INNODISK M.2 (P80) 3TE6 (TYPE 2280)</b> .....	8
<b>FIGURE 2: INNODISK M.2 (P80) 3TE6 WITH HEAT-SPREADING COPPER LAYER DIAGRAM</b> .....	16
<b>FIGURE 3: INNODISK M.2 (P80) 3TE6 BLOCK DIAGRAM</b> .....	17
<b>FIGURE 4: SIGNAL SEGMENT AND POWER SEGMENT</b> .....	20

# 1. Product Overview

## 1.1 Introduction of Innodisk M.2 (P80) 3TE6

Innodisk M.2 (P80) 3TE6 is a NVM Express DRAM-less SSD designed with PCIe interface and industrial 3D TLC NAND Flash. M.2 (P80) 3TE6 supports PCIe Gen III x 4 and it is compliant with NVMe 1.3 providing excellent top and also sustained performance. With sophisticated error detection and correction (ECC) functions, the module can ensure full End-to-End data path protection that secures the data transmission between host system and NAND Flash. In addition, with embedded AES-256 bit engine, your data can be further secured.

## 1.2 Product View and Models

Innodisk M.2 (P80) 3TE6 is available in follow capacities with industrial 3D TLC flash ICs.

M.2 (P80) 3TE6 128GB

M.2 (P80) 3TE6 1TB

M.2 (P80) 3TE6 256GB

M.2 (P80) 3TE6 2T

M.2 (P80) 3TE6 512GB

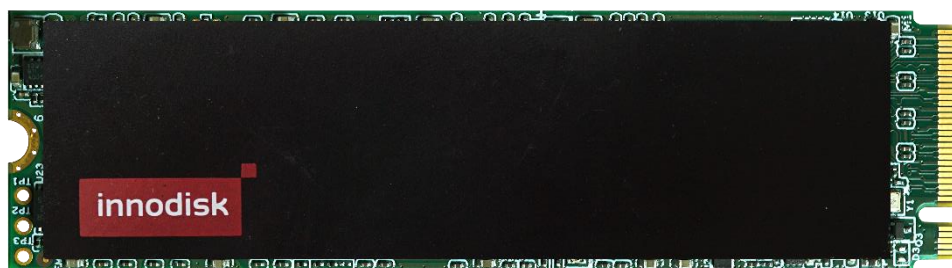

**Figure 1: Innodisk M.2 (P80) 3TE6 (type 2280)**

## 1.3 PCIe Interface

Innodisk M.2 (P80) 3TE6 supports PCIe Gen III interface and compliant with NVMe 1.3. M.2 (P80) 3TE6 can work under PCIe Gen 1, Gen 2 and Gen 3.

Most of operating system includes NVMe in-box driver now. For more information about the driver support in each OS, please visit <https://nvmeexpress.org/drivers/>.



## 2. Product Specifications

### 2.1 Capacity and Device Parameters

M.2 (P80) 3TE6 device parameters are shown in Table 1.

**Table 1: Device parameters**

Capacity	Cylinders	Heads	Sectors	LBA	User Capacity(MB)
128GB	16383	16	63	234441648	114473
256GB				468862128	228937
512GB				937703088	457863
1TB				1875385008	915715
2TB				3750748848	1831420

## 2.2 Performance

Burst Transfer Rate: 4 GB/s

**Table 2: Performance –112 Layers 3D TLC\***

Capacity	Unit	128GB	256GB	512GB	1TB	2TB
Sequential** Read (Q32T1)	MB/s	920	1900	2050	2050	2050
Sequential** Write (Q32T1)		560	1100	1750	1600	1850
Sustained Sequential Read (Avg.) ***		440	750	950	1100	1100
Sustained Sequential Write (Avg.) ***		100	200	400	750	1200
4KB Random** Read (Q8T8)	IOPS	49,000	99,000	189,000	326,000	368,000
4KB Random** Write (Q8T8)		69,000	49,000	281,000	264,000	142,000

Note: \* Performance results are measured in Room Temperature with Out-of-Box devices and may vary depending on overall system setup. In addition, 3TE6 series adopt hybrid mode which enables SLC Cache up to 3% of total user capacity followed by TLC direct write to strike balance between burst performance and steady overall stability.

Note: \*\* Performance results are based on CrystalDiskMark 6.0.2 with file size 1000MB. Unit of 4KB items is I.O.P.S.

Note: \*\*\* Performance results are based on AIDA 64 v5.98 with block size 1MB of Linear Read & Write Test Item.

## 2.3 Electrical Specifications

### 2.3.1 Power Requirement

**Table 3: Innodisk M.2 (P80) 3TE6 Power Requirement**

Item	Symbol	Rating	Unit
Input voltage	V <sub>IN</sub>	+3.3 DC +- 5%	V

### 2.3.2 Power Consumption

**Table 4: 112 Layers 3D TLC**

Model	Power Consumption (W)				
Capacity	128GB	256GB	512GB	1TB	2TB
Read (RMS)	2.4	3.0	3.8	3.9	3.9
Write (RMS)	2.1	2.3	2.9	4.0	5.6
Idle (RMS)	1.1	1.1	1.1	1.1	1.1
Power-On Peak	2.8	3.4	3.9	3.9	5.8

Note: \* Current results may vary depending on system components and power circuit design.

## 2.4 Environmental Specifications

### 2.4.1 Temperature Ranges

**Table 5: Temperature range for M.2 (P80) 3TE6**

Temperature	Range
Operating	Standard Grade: 0°C to +70°C Industry Grade: -40°C to +85°C
Storage	-40°C to +85°C

### 2.4.2 Humidity

Relative Humidity: 10-95%, non-condensing

### 2.4.3 Shock and Vibration

**Table 6: Shock/Vibration Testing for M.2 (P80) 3TE6**

Reliability	Test Conditions	Reference Standards
Vibration	7 Hz to 2K Hz, 20G, 3 axes	IEC 60068-2-6
Mechanical Shock	Duration: 0.5ms, 1500 G, 3 axes	IEC 60068-2-27

### 2.4.4 Mean Time between Failures (MTBF)

Table 7 summarizes the MTBF prediction results for various M.2 (P80) 3TE6 configurations. The analysis was performed using a RAM Commander™ failure rate prediction.

- **Failure Rate:** The total number of failures within an item population, divided by the total number of life units expended by that population, during a particular measurement interval under stated condition.
- **Mean Time between Failures (MTBF):** A basic measure of reliability for repairable items: The mean number of life units during which all parts of the item perform within their specified limits, during a particular measurement interval under stated conditions.

**Table 7: M.2 (P80) 3TE6 MTBF**

Product	Condition	MTBF (Hours)
Innodisk M.2 (P80) 3TE6	Telcordia SR-332 GB, 25°C	>3,000,000

### 2.5 CE and FCC Compatibility

M.2 (P80) 3TE6 conforms to CE and FCC requirements.

### 2.6 RoHS Compliance

M.2 (P80) 3TE6 is fully compliant with RoHS directive.

## 2.7 Reliability

**Table 8: M.2 (P80) 3TE6 TBW**

Parameter	Value	
Read Cycles	Unlimited Read Cycles	
Flash endurance	3,000 P/E cycles	
Error Correct Code	Support(LDPC)	
Data Retention	Under 40°C: 10 Years at Initial NAND Status; 1 Year at NAND Life End	
<b>TBW* (Total Bytes Written) Unit: TB</b>		
<b>Capacity</b>	<b>Sequential workload</b>	<b>Client workload</b>
128GB	340	93
256GB	680	206
512GB	1363	471
1TB	2727	1086
2TB	5454	2600
* Note:		
1. Sequential: Mainly sequential write are estimated by PassMark Burnin Test v8.1 pro.		
2. Client: Follow JESD218 Test method and JESD219A Workload, tested by ULINK. (The capacity lower than 64GB client workload is not specified in JEDEC219A, the values are estimated.)		
3. Based on out-of-box performance.		

## 2.8 Transfer Mode

M.2 (P80) 3TE6 support following transfer mode:

PCIe Gen III 4 GB/s

PCIe Gen II 2 GB/s

PCIe Gen I 1 GB/s

## 2.9 Pin Assignment

Innodisk M.2 (P80) 3TE6 follows standard M.2 spec, socket 3 key M PCIe-based SSD pinout. See Table 9 for M.2 (P80) 3TE6 pin assignment.

**Table 9: Innodisk M.2 (P80) 3TE6 Pin Assignment**

Signal Name	Pin #	Pin #	Signal Name
		75	GND
3.3V	74	73	GND
3.3V	72	71	GND
3.3V	70	69	NC
NC	68	67	NC
Notch	66	65	Notch
Notch	64	63	Notch
Notch	62	61	Notch
Notch	60	59	Notch
NC (Reserved)	58		
NC (Reserved)	56	57	GND
NC	54	55	REFCLKp
CLKREQ# (I/O)(0/3.3V)	52	53	REFCLKn
PERST# (I)(0/3.3V)	50	51	GND
NC	48	49	PERp0
NC	46	47	PERn0
NC	44	45	GND
NC (reserved for SMB_DATA)	42	43	PETp0
NC (reserved for SMB_CLK)	40	41	PETn0
NC	38	39	GND
NC	36	37	PERp1
NC	34	35	PERn1
NC	32	33	GND
NC	30	31	PETp1
NC (reserved for ROM code)	28	29	PETn1
NC	26	27	GND
NC	24	25	PERp2
NC	22	23	PERn2
NC	20	21	GND
3.3V	18	19	PETp2
3.3V	16	17	PETn2
3.3V	14	15	GND

3.3V	12	13	PERp3
LED1# (O) (OD)	10	11	PERn3
NC	8	9	GND
NC	6	7	PETp3
3.3V	4	5	PETn3
3.3V	2	3	GND
		1	GND

## 2.10 Mechanical Dimensions

M.2 Type 2280-S2-M with heat-spreading copper layer

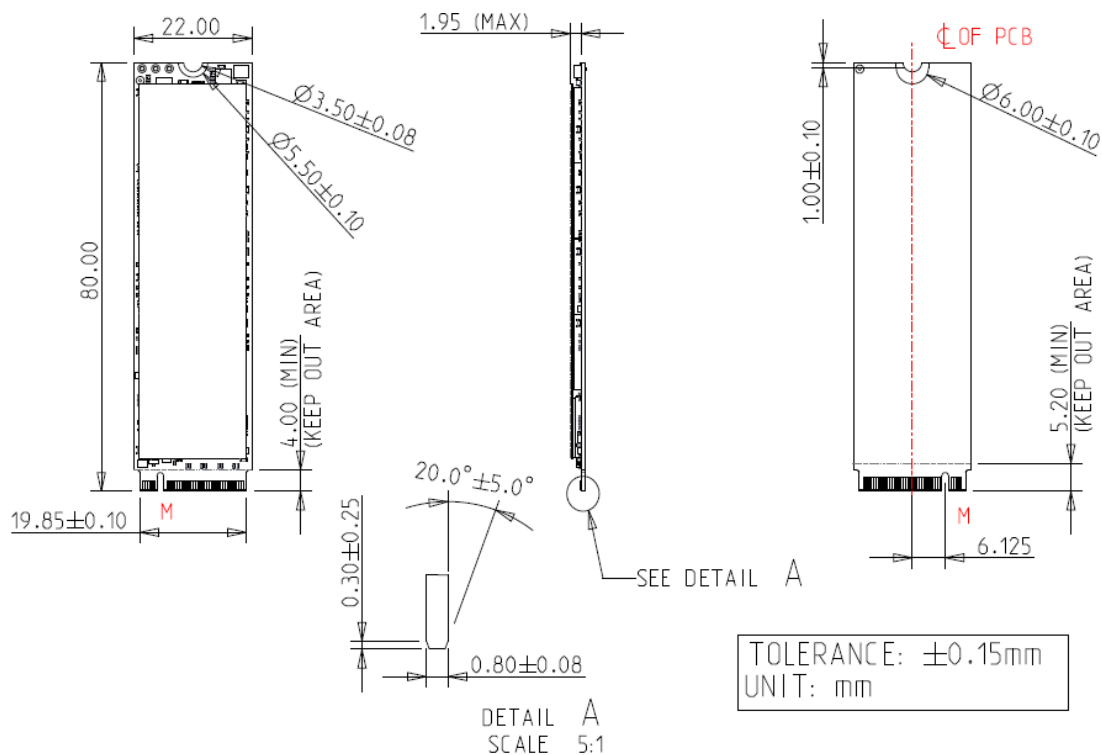

**Figure 2: Innodisk M.2 (P80) 3TE6 with heat-spreading copper layer diagram**

### 2.11 Assembly Weight

An Innodisk M.2 (P80) 3TE6 1TB standard temperature model weights 8 grams.

### 2.12 Seek Time

Innodisk M.2 (P80) 3TE6 is not a magnetic rotating design. There is no seek or rotational latency required.

### 2.13 NAND Flash Memory

Innodisk M.2 (P80) 3TE6 uses industrial 3D TLC NAND flash memory, which is non-volatility, high reliability and high speed memory storage.

### 2.14 Heat-spreading copper layer

Innodisk M.2 (P80) 3TE6 industry temperature models come with a Heat-spreading copper layer installed on top of 3TE6 with dimension of 68x20x0.25 mm. This design will increase 3TE6’s height to 1.95mm max due to the thermal pad and copper layer itself.



# 3. Theory of Operation

## 3.1 Overview

Figure 3 shows the operation of Innodisk M.2 (P80) 3TE6 from the system level, including the major hardware blocks.

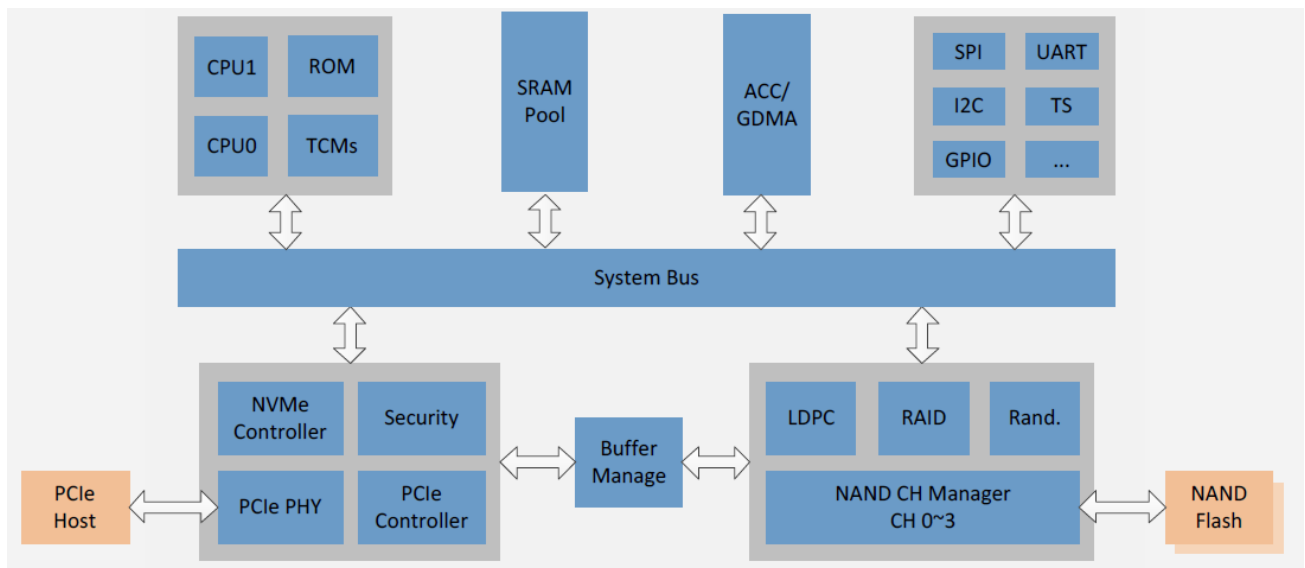

**Figure 3: Innodisk M.2 (P80) 3TE6 Block Diagram**

Innodisk M.2 (P80) 3TE6 integrates a PCIe Gen III x4 controller and NAND flash memories. Communication with the host occurs through the host interface, using the standard NVM protocol. Communication with the flash device(s) occurs through the flash interface.

## 3.2 PCIe Gen III x 4 Controller

Innodisk M.2 (P80) 3TE6 is designed with a PCIe Gen IIIx4 controller which is compliant with NVMe 1.3, up to 32.0Gbps transfer speed. In addition, it is compliant with PCIe Gen. 1, Gen. 2 and Gen. 3 specification. The controller supports up to four channels for flash interface.

### 3.3 Error Detection and Correction

Innodisk M.2 (P80) 3TE6 is designed with hardware LDPC ECC engine with hard-decision and soft-decision decoding. Low-density parity-check (LDPC) codes have excellent error correcting performance close to the Shannon limit when decoded with the belief-propagation (BP) algorithm using soft-decision information.

### 3.4 Wear-Leveling

Flash memory can be erased with a limited number of cycles. This number is called the **erase cycle limit** or **write endurance limit** and is defined by the flash NAND vendor. The erase cycle limit applies to each individual erase block in the flash device.

Innodisk M.2 (P80) 3TE6 uses a combination of two types of wear leveling- dynamic and static wear leveling- to distribute write cycling across an SSD and balance erase count of each block, thereby extending device lifetime.

### 3.5 Bad Blocks Management

Bad Blocks are blocks that contain one or more invalid bits whose reliability are not guaranteed. The Bad Blocks may be presented while the SSD is shipped, or may develop during the lifetime of the SSD. When a Bad Block is detected, it will be flagged as unusable block by firmware. The SSD implement Bad Blocks management that consists of Bad Blocks replacement and Error Correcting to avoid data error occurred. The functions will be enabled automatically to transfer data from Bad Blocks to spare blocks, and correct error bit.

### 3.6 Garbage Collection/TRIM

Garbage collection and TRIM technology is used to maintain data consistency and perform continual data cleansing on SSDs. It runs as a background process, freeing up valuable controller resources while sorting good data into available blocks, and deleting bad blocks. It also significantly reduces write operations to the drive, thereby increasing the SSD's speed and lifespan.

### 3.7 End to End Data Path Protection

End-to-end Data Path Protection that secures the data transmission between host system and NAND Flash. In the transmission path, no matter in or out, all buffer and storage implement Error Code Correction that optimizes the data integrity in the whole transmission of SSD.

### 3.8 Thermal Management

M.2 (P80) 3TE6 has built-in thermal sensor which can detect environment temperature of SSD. In the meantime, firmware will monitor the thermal sensor to prevent any failure of overheating. During extreme temperature, firmware will adjust the data transfer behavior to maintain the SSD's reliable operation.

### 3.9 iDataGuard

Innodisk's iData Guard is a comprehensive data protection mechanism that functions before and after a sudden power outage to the SSD. Low-power detection terminates data writing before an abnormal power-off, while table-remapping after power-on deletes corrupt data and maintains data integrity. Innodisk's iData Guard provides effective power cycling management, preventing data stored in flash from degrading with use.

### 3.10 AES function

M.2 (P80) 3TE6 has built-in AES-128/256 hardware encryption engine to encode and decode data to ensure efficiency and data security. In other words, there is no impact on CPU performance, as the controller will handle all encryption and decryption.

### 3.11 TCG OPAL

OPAL is a set of specifications for features of data storage devices that enhance security. These specifications are published by the Trusted Computing Group's Storage Work Group. Innodisk 3TE6 is compliant with TCG OPAL 2.0\*. The capability of TCG OPAL Security mode allows multiple users with independent access control to read/write/erase independent data areas (LBA ranges). Each locking range adjusts by authenticated authority. Note that by default there is a single "Global Range" that encompasses the whole user data area. In TCG Opal Security Mode, Revert, Revert SP and GenKey command can erase all of data including global range and locking range; in the meantime generate the new encrypted key.

\* You need to install TCG OPAL software to implement OPAL function, which is supplied by TCG OPAL software developed company.

# 4. Installation Requirements

## 4.1 M.2 (P80) 3TE6 Pin Directions

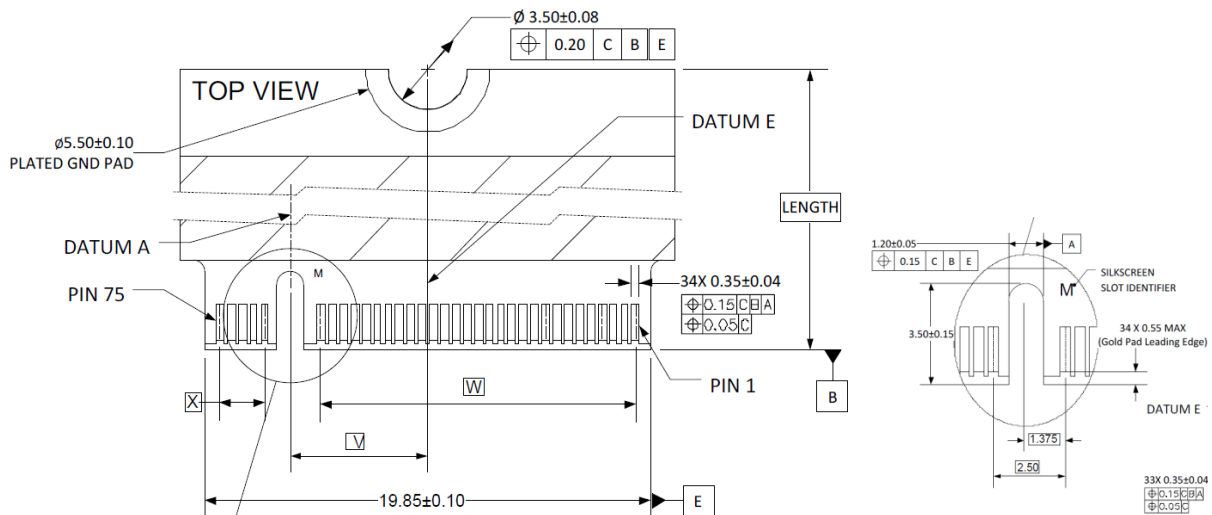

**Figure 4: Signal Segment and Power Segment**

## 4.2 Electrical Connections for M.2 (P80) 3TE6

M.2 interconnect is based on a 75 position Edge Card connector. The 75 position connector is intended to be keyed so as to distinguish between families of host interfaces and the various Sockets used in general Platforms. M.2(P80) 3TE6 is compliant with M.2 Socket 3 key M.

## 4.3 Device Drive

M.2 (P42) 3TE6 is compliant with NVMe 1.3. Both Operation System and BIOS should include NVMe driver to compatible with NVMe device. Nowadays, most of OS includes NVMe in-box driver now. For more information about the driver support in each OS, please visit the website <https://nvmexpress.org/drivers/>. For BIOS NVMe driver support please contact with motherboard manufacturers.

## 5. SMART / Health Information

This log page is used to provide SMART and general health information. The information provided is over the life of the controller and is retained across power cycles. More details about Set Features command; please refer to NVM Express 1.3

### 5.1 Get Log Page(Log Identifier 02h)

Innodisk 3TE6 series SMART / Health Information Log are listed in following table.

**Table 10: Get Log Page – SMART / Health Information Log**

Bytes	Description														
0	<p><b>Critical Warning:</b> This field indicates critical warnings for the state of the controller. Each bit corresponds to a critical warning type; multiple bits may be set. If a bit is cleared to '0', then that critical warning does not apply. Critical warnings may result in an asynchronous event notification to the host. Bits in this field represent the current associated state and are not persistent.</p> <table border="1"> <thead> <tr> <th>Bit</th> <th>Definition</th> </tr> </thead> <tbody> <tr> <td>0</td> <td>If set to '1', then the available spare space has fallen below the threshold.</td> </tr> <tr> <td>1</td> <td>If set to '1', then a temperature is above an over temperature threshold or below an under</td> </tr> <tr> <td>2</td> <td>If set to '1', then the NVM subsystem reliability has been degraded due to significant media related</td> </tr> <tr> <td>3</td> <td>If set to '1', then the media has been placed in read only mode.</td> </tr> <tr> <td>4</td> <td>If set to '1', then the volatile memory backup device has failed. This field is only valid if the</td> </tr> <tr> <td>7:5</td> <td>Reserved</td> </tr> </tbody> </table>	Bit	Definition	0	If set to '1', then the available spare space has fallen below the threshold.	1	If set to '1', then a temperature is above an over temperature threshold or below an under	2	If set to '1', then the NVM subsystem reliability has been degraded due to significant media related	3	If set to '1', then the media has been placed in read only mode.	4	If set to '1', then the volatile memory backup device has failed. This field is only valid if the	7:5	Reserved
	Bit	Definition													
	0	If set to '1', then the available spare space has fallen below the threshold.													
	1	If set to '1', then a temperature is above an over temperature threshold or below an under													
	2	If set to '1', then the NVM subsystem reliability has been degraded due to significant media related													
	3	If set to '1', then the media has been placed in read only mode.													
	4	If set to '1', then the volatile memory backup device has failed. This field is only valid if the													
	7:5	Reserved													
1:2	<p><b>Composite Temperature:</b> Contains a value corresponding to a temperature in degrees Kelvin that represents the current composite temperature of the controller and namespace(s) associated with that controller. The manner in which this value is computed is implementation specific and may not represent the actual temperature of any physical point in the NVM subsystem. The value of this field</p>														

	<p>may be used to trigger an asynchronous event.</p> <p>Warning and critical overheating composite temperature threshold values are reported by the WCTEMP and CCTEMP fields in the Identify Controller data structure.</p>
3	<p><b>Available Spare:</b> Contains a normalized percentage (0 to 100%) of the remaining spare capacity available.</p>
4	<p><b>Available Spare Threshold:</b> When the Available Spare falls below the threshold indicated in this field, an asynchronous event completion may occur. The value is indicated as a normalized percentage (0 to 100%).</p>
5	<p><b>Percentage Used:</b> Contains a vendor specific estimate of the percentage of NVM subsystem life used based on the actual usage and the manufacturer’s prediction of NVM life. A value of 100 indicates that the estimated endurance of the NVM in the NVM subsystem has been consumed, but may not indicate an NVM subsystem failure. The value is allowed to exceed 100. Percentages greater than 254 shall be represented as 255. This value shall be updated once per power-on hour (when the controller is not in a sleep state).</p> <p>Refer to the JEDEC JESD218A standard for SSD device life and endurance measurement techniques.</p>
6:31	<p><b>Reserved</b></p>
32:47	<p><b>Data Units Read:</b> Contains the number of 512 byte data units the host has read from the controller; this value does not include metadata. This value is reported in thousands (i.e., a value of 1 corresponds to 1000 units of 512 bytes read) and is rounded up. When the LBA size is a value other than 512 bytes, the controller shall convert the amount of data read to 512 byte units.</p> <p>For the NVM command set, logical blocks read as part of Compare and Read operations shall be included in this value.</p>
48:63	<p><b>Data Units Written:</b> Contains the number of 512 byte data units the host has written to the controller; this value does not include metadata. This value is reported in thousands (i.e., a value of 1 corresponds to 1000 units of 512 bytes written) and is rounded up. When the LBA size is a value other than 512 bytes, the controller shall convert the amount of data written to 512 byte units.</p> <p>For the NVM command set, logical blocks written as part of Write operations shall be included in this value. Write Uncorrectable commands shall not impact this value.</p>

64:79	<p><b>Host Read Commands:</b> Contains the number of read commands completed by the controller.</p> <p>For the NVM command set, this is the number of Compare and Read commands.</p>
80:95	<p><b>Host Write Commands:</b> Contains the number of write commands completed by the controller.</p> <p>For the NVM command set, this is the number of Write commands.</p>
96:111	<p><b>Controller Busy Time:</b> Contains the amount of time the controller is busy with I/O commands. The controller is busy when there is a command outstanding to an I/O Queue (specifically, a command was issued via an I/O Submission Queue Tail doorbell write and the corresponding completion queue entry has not been posted yet to the associated I/O Completion Queue). This value is reported in minutes.</p>
112:127	<p><b>Power Cycles:</b> Contains the number of power cycles.</p>
128:143	<p><b>Power On Hours:</b> Contains the number of power-on hours. This may not include time that the controller was powered and in a non-operational power state.</p>
144:159	<p><b>Unsafe Shutdowns:</b> Contains the number of unsafe shutdowns. This count is incremented when a shutdown notification (CC.SHN) is not received prior to loss of power.</p>
160:175	<p><b>Media and Data Integrity Errors:</b> Contains the number of occurrences where the controller detected an unrecovered data integrity error. Errors such as uncorrectable ECC, CRC checksum failure, or LBA tag mismatch are included in this field.</p>
176:191	<p><b>Number of Error Information Log Entries:</b> Contains the number of Error Information log entries over the life of the controller.</p>
192:195	<p><b>Warning Composite Temperature Time:</b> Contains the amount of time in minutes that the controller is operational and the Composite Temperature is greater than or equal to the Warning Composite Temperature Threshold (WCTEMP) field and less than the Critical Composite Temperature Threshold (CCTEMP) field in the Identify Controller data structure.</p> <p>If the value of the WCTEMP or CCTEMP field is 0h, then this field is always cleared to 0h regardless of the Composite Temperature value.</p>
196:199	<p><b>Critical Composite Temperature Time:</b> Contains the amount of time in minutes that the controller is operational and the Composite Temperature is greater than the Critical Composite Temperature Threshold (CCTEMP) field in the Identify</p>

	<p>Controller data structure.</p> <p>If the value of the CCTEMP field is 0h, then this field is always cleared to 0h regardless of the Composite Temperature value.</p>
200:201	<p><b>Temperature Sensor 1:</b> Contains the current temperature reported by controller’s temperature sensor.</p>
202:203	<p><b>Temperature Sensor 2:</b> Contains the current temperature reported by external temperature sensor.</p>
204:205	<p><b>Temperature Sensor 3:</b> Contains the current temperature reported by channel zero CE zero NAND’s temperature sensor.</p>
206:207	<p><b>Temperature Sensor 4:</b> Contains the current temperature reported by last channel CE zero NAND’s temperature sensor.</p>
208:209	<p><b>Temperature Sensor 5:</b> Contains the current temperature reported by temperature sensor 5.</p>
210:211	<p><b>Temperature Sensor 6:</b> Contains the current temperature reported by temperature sensor 6.</p>
212:213	<p><b>Temperature Sensor 7:</b> Contains the current temperature reported by temperature sensor 7.</p>
214:215	<p><b>Temperature Sensor 8:</b> Contains the current temperature reported by temperature sensor 8.</p>
216:219	<p><b>Thermal Management Temperature 1 Transition Count:</b> Lower Power Active Power States or Performed Vendor Specific Thermal Management</p>
220:223	<p><b>Thermal Management Temperature 2 Transition Count:</b> Lower Power Active Power States or Performed Vendor Specific Thermal Management</p>
224:227	<p><b>Total Time For Thermal Management Temperature 1:</b> Duration in Lower Power Active Power States or Performed Vendor Specific Thermal Management</p>
228:231	<p><b>Total Time For Thermal Management Temperature 2:</b> Duration in Lower Power Active Power States or Performed Vendor Specific Thermal Management</p>
232:337	<p><b>Reserved</b></p>
338:345	<p><b>Later Bad Count</b></p>
346:353	<p><b>Power-On hours Count</b></p>
354:361	<p><b>Drive Power Cycle Count</b></p>



362:369	<b>Total Bad Block Count</b>
370:377	<b>User Max Erase Count</b>
378:385	<b>User Avg Erase Count</b>
386:393	<b>Device Life</b>
394:401	<b>Spare Block Count</b>
402:409	<b>Program Fail Count</b>
410:417	<b>Erase Fail Count</b>
418:425	<b>Unexpected Power Loss Count</b>
426:433	<b>Temperature ( Kelvin - K °K)</b>
434:441	<b>Flash ID</b>
442:449	<b>Later Bad Block Info (Read / Write / Erase)</b>
450:457	<b>Total LBAs Written (uint = 32MB)</b>
458:465	<b>Total LBAs Read (uint = 32MB)</b>

## 6. Part Number Rule

CODE	1	2	3	4	5	6	7	8	9	10	11	12	13	14	15	16	17	18	19	20	
	D	E	M	2	8	-	A	2	8	D	D	2	K	C	A	D	F	-	X	X	X
<b>Definition</b>																					
<b>Code 1<sup>st</sup> (Disk)</b>											<b>Code 14<sup>th</sup> (Operation Temperature)</b>										
D : Disk											W: Industrial Grade (-40°C~ +85°C)										
<b>Code 2<sup>nd</sup> (Feature set)</b>																					
E : Embedded series																					
<b>Code 3<sup>rd</sup> ~5<sup>th</sup> (Form factor)</b>											<b>Code 15<sup>th</sup> (Internal control)</b>										
M28: M.2 Type 2280-S2-M											A~Z: BGA PCB version.										
<b>Code 7<sup>th</sup> ~9<sup>th</sup> (Capacity)</b>											<b>Code 16<sup>th</sup> (Channel of data transfer)</b>										
A28: 128GB			B56: 256GB			C12: 512GB					D: Dual Channels										
01T: 1TB			02T: 2TB								Q: Quad Channels										
<b>Code 10<sup>th</sup> ~12<sup>th</sup> (Controller)</b>											<b>Code 17<sup>th</sup> (Flash Type)</b>										
DD2: 3TE6 Series with AES function											F: Kioxia 3D TLC										
<b>Code 13<sup>th</sup> (Flash mode)</b>											<b>Code 19<sup>th</sup> ~21<sup>th</sup> (Customize code)</b>										
K: 112 Layers 3D TLC																					