

mSATA mini

3IE4 Series

Customer: _____

Customer

Part

Number: _____

Innodisk

Part

Number: _____

Innodisk

Model Name: _____

Date: _____

Innodisk Approver	Customer Approver

**Total Solution For
Industrial Flash Storage**

Table of contents

LIST OF FIGURES	6
1. PRODUCT OVERVIEW	7
1.1 INTRODUCTION OF INNODISK mSATA MINI 3IE4	7
1.2 PRODUCT VIEW AND MODELS	7
1.3 SATA INTERFACE.....	7
2. PRODUCT SPECIFICATIONS.....	8
2.1 CAPACITY AND DEVICE PARAMETERS.....	8
2.2 PERFORMANCE	8
2.3 ELECTRICAL SPECIFICATIONS	8
2.3.1 Power Requirement.....	8
2.3.2 Power Consumption	9
2.4 ENVIRONMENTAL SPECIFICATIONS	9
2.4.1 Temperature Ranges	9
2.4.2 Humidity.....	9
2.4.3 Shock and Vibration	9
2.4.4 Mean Time between Failures (MTBF)	9
2.5 CE AND FCC COMPATIBILITY	10
2.6 RoHS COMPLIANCE	10
2.7 RELIABILITY	10
3. BASED ON OUT-OF-BOX PERFORMANCE.	10
2.8 TRANSFER MODE	10
2.9 PIN ASSIGNMENT	10
2.10 MECHANICAL DIMENSIONS.....	12
2.11 ASSEMBLY WEIGHT	12
2.12 SEEK TIME	12
2.13 NAND FLASH MEMORY.....	12
3. THEORY OF OPERATION	13
3.1 OVERVIEW.....	13
3.2 SATA III CONTROLLER	13
3.3 ERROR DETECTION AND CORRECTION.....	14
3.4 WEAR-LEVELING	14
3.5 BAD BLOCKS MANAGEMENT	14
3.6 iPOWER GUARD.....	14
3.7 GARBAGE COLLECTION.....	14
3.8 TRIM	14
4. INSTALLATION REQUIREMENTS	15

4.1 mSATA MINI 3IE4 PIN DIRECTIONS.....	15
4.2 ELECTRICAL CONNECTIONS FOR MSATA MINI 3IE4	15
4.3 DEVICE DRIVE	15
5. PART NUMBER RULE	16

REVISION HISTORY

Revision	Description	Date
Preliminary	First Released	Feb., 2017
1.0	Officially Released	April., 2017
1.1	Remove iDataGuard/ Add iPowerGuard	Jan.,2021

List of Tables

TABLE 1: DEVICE PARAMETERS	8
TABLE 2: PERFORMANCE	8
TABLE 3: INNODISK MSATA MINI 3IE4 POWER REQUIREMENT	8
TABLE 4: POWER CONSUMPTION	9
TABLE 5: TEMPERATURE RANGE FOR MSATA MINI 3IE4	9
TABLE 6: SHOCK/VIBRATION TESTING FOR MSATA MINI 3IE4	9
TABLE 7: MSATA MINI 3IE4 MTBF	10
TABLE 8: INNODISK MSATA MINI 3IE4 PIN ASSIGNMENT	11

List of Figures

FIGURE 1: INNODISK mSATA MINI 3IE4	7
FIGURE 2: INNODISK mSATA MINI 3IE4 BLOCK DIAGRAM	13
FIGURE 3: SIGNAL SEGMENT AND POWER SEGMENT	15

1. Product Overview

1.1 Introduction of Innodisk mSATA mini 3IE4

Innodisk mSATA mini 3IE4 which is designed with mSATA mini form factor by JEDEC MO-300/MO-300B , supporting SATA III standard (6.0Gb/s), achieves excellent performance up to 4CH standard by cost effective controller with 2CH. Regarding of mechanical interference, Innodisk mSATA mini 3IE4 absolutely replaces the traditional hard disk and makes personal computer, in any field, smaller and easier.

With Innodisk L³ FW architecture, combining our signature 4K mapping algorithm L² FW architecture with powerful LDPC technology, 3ME4 series has outstanding high IOPS, better data integrity and extended lifespan through reducing the bad block number happening.

For real industrial application, 3IE4 series is built in thermal sensor to monitor the environment temperature. iData Guard, the power loss management mechanism developed by Innodisk, ensures data integrity while power sudden loss happened.

1.2 Product View and Models

Innodisk mSATA mini 3IE4 is available in follow capacities within MLC flash ICs.

[mSATA mini 3IE4 08GB](#) [mSATA mini 3IE4 16GB](#) [mSATA mini 3IE4 32GB](#)

[mSATA mini 3IE4 64GB](#)



Figure 1: Innodisk mSATA mini 3IE4

1.3 SATA Interface

Innodisk mSATA mini 3IE4 supports SATA III(6.0Gb/s) interface, and compliant with SATA I (1.5Gb/s) and SATA II(3.0Gb/s).

2. Product Specifications

2.1 Capacity and Device Parameters

mSATA mini 3IE4 device parameters are shown in Table 1.

Table 1: Device parameters

Capacity	Cylinders	Heads	Sectors	LBA	User Capacity(MB)
08GB	16383	16	63	15649200	7,641
16GB	31029	16	63	31277232	15,272
32GB	62037	16	63	62533296	30,533
64GB	124053	16	63	125045424	61,057

2.2 Performance

Burst Transfer Rate: 6.0Gbps

Table2: Performance

Capacity	8GB		16GB	32GB	64GB
	1CH	2CH			
Sequential Read (max.)	250 MB/sec	290 MB/sec	500 MB/sec	530 MB/sec	530 MB/sec
Sequential Write (max.)	80 MB/sec	200 MB/sec	160 MB/sec	330 MB/sec	340 MB/sec
4KB Random** Read (QD32)	12,000 IOPS	18,000 IOPS	23,000 IOPS	30,000 IOPS	31,000 IOPS
4KB Random** Write (QD32)	12,000 IOPS	27,000 IOPS	27,000 IOPS	30,500 IOPS	31,000 IOPS

Note: the information is based on CrystalDiskMark 5.1.2 with file size 1000MB test pattern

2.3 Electrical Specifications

2.3.1 Power Requirement

Table 3: Innodisk mSATA mini 3IE4 Power Requirement

Item	Symbol	Rating	Unit
Input voltage	V _{IN}	+3.3 DC +- 5%	V

2.3.2 Power Consumption

Table 4: Power Consumption

Mode	Power Consumption (mA)
Read	130 (max.)
Write	205 (max.)
Idle	84 (max.)

* Target: 256GB mSATA mini 3IE4

2.4 Environmental Specifications

2.4.1 Temperature Ranges

Table 5: Temperature range for mSATA mini 3IE4

Temperature	Range
Operating	Standard Grade: 0°C to +70°C
	Industrial Grade: -40°C to +85°C
Storage	-40°C to +85°C

2.4.2 Humidity

Relative Humidity: 10-95%, non-condensing

2.4.3 Shock and Vibration

Table 6: Shock/Vibration Testing for mSATA mini 3IE4

Reliability	Test Conditions	Reference Standards
Vibration	7 Hz to 2K Hz, 20G, 3 axes	IEC 68-2-6
Mechanical Shock	Duration: 0.5ms, 1500 G, 3 axes	IEC 68-2-27

2.4.4 Mean Time between Failures (MTBF)

Table 7 summarizes the MTBF prediction results for various mSATA mini 3IE4 configurations. The analysis was performed using a RAM Commander™ failure rate prediction.

- **Failure Rate:** The total number of failures within an item population, divided by the total number of life units expended by that population, during a particular measurement interval under stated condition.
- **Mean Time between Failures (MTBF):** A basic measure of reliability for repairable items: The mean number of life units during which all parts of the item perform within their specified limits, during a particular measurement interval under stated conditions.

Table 7: mSATA mini 3IE4 MTBF

Product	Condition	MTBF (Hours)
Innodisk mSATA mini 3IE4	Telcordia SR-332 GB, 25°C	>3,000,000

2.5 CE and FCC Compatibility

mSATA mini 3IE4 conforms to CE and FCC requirements.

2.6 RoHS Compliance

mSATA mini 3IE4 is fully compliant with RoHS directive.

2.7 Reliability

Parameter	Value	
Read Cycles	Unlimited Read Cycles	
Flash endurance	20,000 P/E cycles	
Wear-Leveling Algorithm	Support	
Bad Blocks Management	Support	
Error Correct Code	Support	
TBW* (Total Bytes Written) Units: TB		
Capacity	Sequential workload	Client workload
08GB	156.3	104.2
16GB	312.5	208.3
32GB	624.0	416.7
64GB	1250	833.3
* Note:		
1. Sequential: Mainly sequential write, tested by Vdbench.		
2. Client: Follow JESD218 Test method and JESD219A Workload, tested by ULINK. (The capacity lower than 64GB client workload is not specified in JEDEC219A, the values are estimated.)		
3. Based on out-of-box performance.		

2.8 Transfer Mode

mSATA mini 3IE4 support following transfer mode:

Serial ATA III 6.0Gbps

Serial ATA II 3.0Gbps

Serial ATA I 1.5Gbps

2.9 Pin Assignment

Innodisk mSATA mini 3IE4 uses a standard SATA pin-out. See Table 8 for mSATA mini 3IE4 pin assignment.

Table 8: Innodisk mSATA mini 3IE4 Pin Assignment

Signal Name	Pin #	Pin #	Signal Name
GND	51	52	+3.3V
DAS	49	50	GND
NC	47	48	NC
NC	45	46	NC
NC	43	44	DEVSLP
+3.3V	41	42	NC
+3.3V	39	40	GND
GND	37	38	NC
GND	35	36	NC
RX+	33	34	GND
RX-	31	32	NC
GND	29	30	NC
GND	27	28	NC
TX-	25	26	GND
TX+	23	24	+3.3V
GND	21	22	NC
NC	19	20	NC
NC	17	18	GND
GND	15	16	NC
NC	13	14	NC
NC	11	12	NC
GND	9	10	NC
NC	7	8	NC

NC	5	6	NC
NC	3	4	GND
NC	1	2	+3.3V

2.10 Mechanical Dimensions

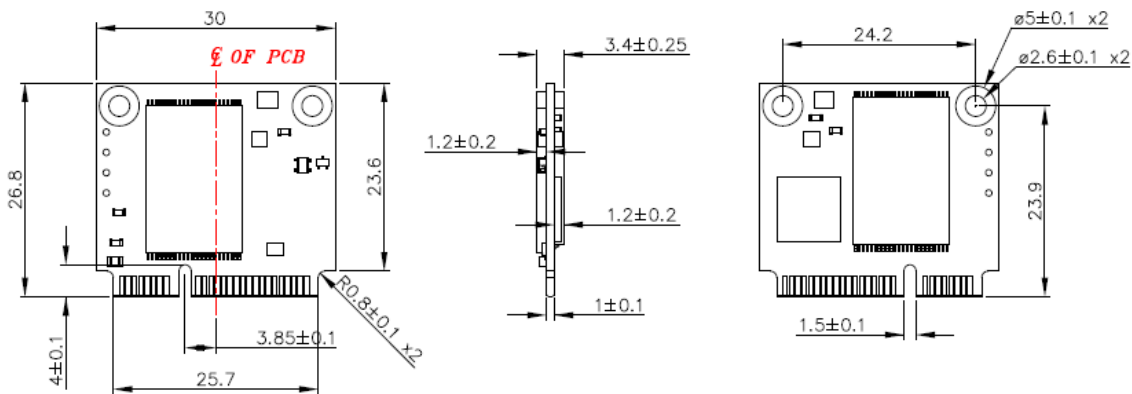

UNIT: mm
TOLERANCE: ±0.15mm

2.11 Assembly Weight

An Innodisk mSATA mini 3IE4 with flash ICs, 32GB's weight is 8 grams approximately.

2.12 Seek Time

Innodisk mSATA mini 3IE4 is not a magnetic rotating design. There is no seek or rotational latency required.

2.13 NAND Flash Memory

Innodisk mSATA mini 3IE4 uses Multi Level Cell (MLC) NAND flash memory, which is non-volatility, high reliability and high speed memory storage. Each cell stores 2 bits or holds four states per cell. Read or Write data to flash memory for SSD is control by microprocessor.

3. Theory of Operation

3.1 Overview

Figure 2 shows the operation of Innodisk mSATA mini 3IE4 from the system level, including the major hardware blocks.

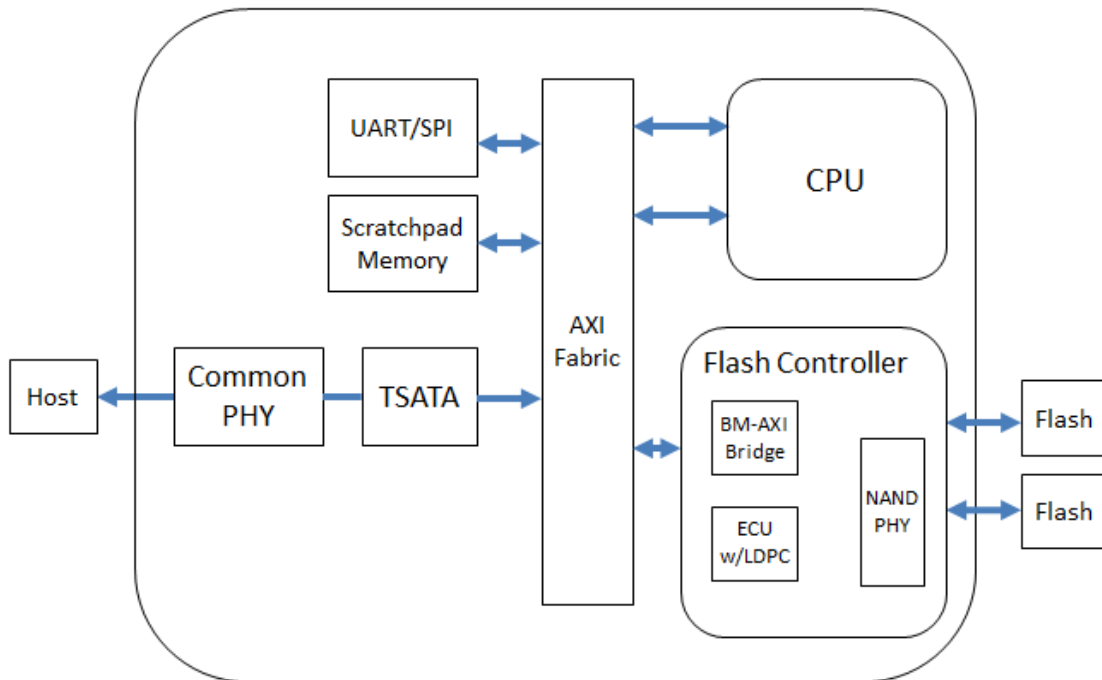

Figure 2: Innodisk mSATA mini 3IE4 Block Diagram

Innodisk mSATA mini 3IE4 integrates a SATA III controller and NAND flash memories. Communication with the host occurs through the host interface, using the standard ATA protocol. Communication with the flash device(s) occurs through the flash interface.

3.2 SATA III Controller

Innodisk mSATA mini 3IE4 is designed with 88NV1120, a SATA III 6.0Gbps (Gen. 3) controller. The Serial ATA physical, link and transport layers are compliant with Serial ATA Gen 1, Gen 2 and Gen 3 specification (Gen 3 supports 1.5Gbps/3.0Gbps/6.0Gbps data rate). The controller has 2 channels for flash interface.

3.3 Error Detection and Correction

Innodisk mSATA mini 3IE4 is designed with hardware LDPC ECC engine with hard-decision and Soft-decision decoding. Low-density parity-check (LDPC) codes have excellent error correcting performance close to the Shannon limit when decoded with the belief-propagation (BP) algorithm using soft-decision information.

3.4 Wear-Leveling

Flash memory can be erased within a limited number of times. This number is called the **erase cycle limit** or **write endurance limit** and is defined by the flash array vendor. The erase cycle limit applies to each individual erase block in the flash device.

Innodisk mSATA mini 3IE4 uses a static wear-leveling algorithm to ensure that consecutive writes of a specific sector are not written physically to the same page/block in the flash. This spreads flash media usage evenly across all pages, thereby extending flash lifetime.

3.5 Bad Blocks Management

Bad Blocks are blocks that contain one or more invalid bits whose reliability are not guaranteed. The Bad Blocks may be presented while the SSD is shipped, or may develop during the life time of the SSD. When the Bad Blocks is detected, it will be flagged, and not be used anymore. The SSD implement Bad Blocks management, Bad Blocks replacement, Error Correct Code to avoid data error occurred. The functions will be enabled automatically to transfer data from Bad Blocks to spare blocks, and correct error bit.

3.6 iPower Guard

Unstable power source is a common challenge for the devices in an extreme environment. Hardware-based preventive features will protect the SSD from unstable voltage levels by extending the ramp-up time during startup to ensure that the voltage has stabilized before SSD switching on. In addition, when system shutdown or during a quick restart, the residual voltage can cause issues. It's mitigated by tweaking the hardware to minimize the residual voltage.

3.7 Garbage Collection

Garbage collection is used to maintain data consistency and perform continual data cleansing on SSDs. It runs as a background process, freeing up valuable controller resources while sorting good data into available blocks, and deleting bad blocks. It also significantly reduces write operations to the drive, thereby increasing the SSD's speed and lifespan.

3.8 Trim

The Trim command is designed to enable the operating system to notify the SSD which pages no longer contain valid data due to erases either by the user or operating system itself. During a delete operation, the OS will mark the sectors as free for new data and send a Trim command to the SSD to mark them as not containing valid data. After that the SSD knows not to preserve the contents of the block when writing a page, resulting in less write amplification with fewer writes to the flash, higher write speed, and increased drive life.

4. Installation Requirements

4.1 mSATA mini 3IE4 Pin Directions

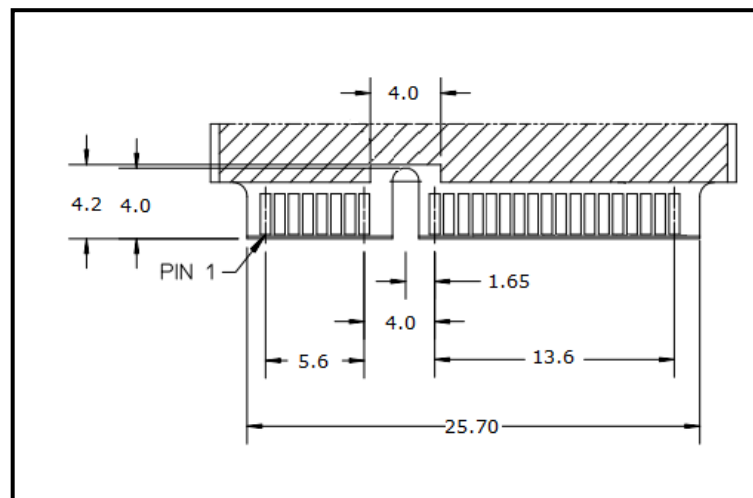

Figure 3: Signal Segment and Power Segment

4.2 Electrical Connections for mSATA mini 3IE4

A Serial ATA device may be either directly connected to a host or connected to a host through an adaptor card. The SATA interface has a separate connector for the power supply. Please refer to the pin description for further details.

4.3 Device Drive

No additional device drives are required. The Innodisk mSATA mini 3IE4 can be configured as a boot device.

5. Part Number Rule

CODE	1	2	3	4	5	6	7	8	9	10	11	12	13	14	15	16	17	18	19	20	21
	D	H	M	S	M	-	3	2	G	M	4	1	B	C	1	D	C	-	X	X	X
Description	Disk	mSATA mini Regular				Capacity	Controller			Flash Mode	Operation Temp.	Internal Control	CH	Flash Type					Customized Code		
Definition																					
Code 1st (Disk)											Code 13th (Flash Mode)										
D : Disk											B: Synchronous Flash for Toshiba 15nm										
Code 2nd ~ 5th (Form Factor)											Code 14th (Operation Temperature)										
HMSM: mSATA mini iSLC											C: Standard Grade (0°C ~ +70°C)										
											W: Industrial Grade (-40°C ~ +85°C)										
Code 7th ~9th (Capacity)											Code 15th (Internal control)										
08G: 08GB											1~9: TSOP PCB version										
16G: 16GB																					
32G: 32GB											Code 16th (Channel of data transfer)										
64G: 64GB											S: Single Channel										
											D: Dual Channels										
											Code 17th (Flash Type)										
Code 10th ~12th (Controller)											C: Toshiba MLC										
M41: 88NV1120											Code 19th~21th (Customized Code)										

RoHS 自我宣告書 (RoHS Declaration of Conformity)

Manufacturer Product: All Innodisk EM Flash and Dram products

- 一、宜鼎國際股份有限公司（以下稱本公司）特此保證售予貴公司之所有產品，皆符合歐盟 2011/65/EU 關於 RoHS 之規範要求。

Innodisk Corporation declares that all products sold to the company, are complied with European Union RoHS Directive (2011/65/EU) requirement.

- 二、本公司同意因本保證書或與本保證書相關事宜有所爭議時，雙方宜友好協商，達成協議。

Innodisk Corporation agrees that both parties shall settle any dispute arising from or in connection with this Declaration of Conformity by friendly negotiations.

Name of hazardous substance	Limited of RoHS ppm (mg/kg)
鉛 (Pb)	< 1000 ppm
汞 (Hg)	< 1000 ppm
鎘 (Cd)	< 100 ppm
六價鉻 (Cr 6+)	< 1000 ppm
多溴聯苯 (PBBs)	< 1000 ppm
多溴二苯醚 (PBDEs)	< 1000 ppm

立保證書人 (Guarantor)

Company name 公司名稱：Innodisk Corporation 宜鼎國際股份有限公司

Company Representative 公司代表人：Randy Chien 簡川勝

Company Representative Title 公司代表人職稱：Chairman 董事長

Date 日期：2016 / 08 / 04



宜鼎國際股份有限公司
Innodisk Corporation

Tel:(02)7703-3000 Fax:(02) 7703-3555 Internet: <http://www.innodisk.com/>

REACH Declaration of Conformity

Manufacturer Product: All Innodisk EM Flash and Dram products

1.宜鼎國際股份有限公司（以下稱本公司）特此保證此售予貴公司之產品，皆符合歐盟化學品法案(Registration, Evaluation and Authorization of Chemicals; REACH)之規定

(<http://www.echa.europa.eu/de/candidate-list-table> last updated: 17/12/2015)。所提供之產品包含：(1) 產品或產品所使用到的所有原物料；(2)包裝材料；(3)設計、生產及重工過程中所使用到的所有原物料。

We Innodisk Corporation hereby declare that our products are in compliance with the requirements according to the REACH Regulation

(<http://www.echa.europa.eu/de/candidate-list-table> last updated: 17/12/2015).

Products include: 1) Product and raw material used by the product; 2) Packaging material; 3) Raw material used in the process of design, production and rework

2.本公司同意因本保證書或與本保證書相關事宜有所爭議時，雙方宜友好協商，達成協議。

InnoDisk Corporation agrees that both parties shall settle any dispute arising from or in connection with this Declaration of Conformity by friendly negotiations.

立保證書人 (Guarantor)

Company name 公司名稱：InnoDisk Corporation 宜鼎國際股份有限公司

Company Representative 公司代表人：Richard Lee 李鐘亮

Company Representative Title 公司代表人職稱：Chairman 董事長

Date 日期：2016 / 01 / 25





VERIFICATION OF COMPLIANCE

This Verification of Compliance is hereby issued to the below named company. The test results of this report relate only to the tested sample identified in this report.

**Technical Standard: EMC DIRECTIVE 2014/30/EU
(EN55032 / EN55024)**

General Information

Applicant: Innodisk Corporation
5F., No. 237, Sec. 1, Datong Rd., Xizhi Dist.,
New Taipei City 22161, Taiwan (R.O.C)

Product Description

EUT Description: mSATA mini
Brand Name: Innodisk
Model Number: mSATA mini 3S*#-&
S:Flash type: (S:SLC, I:iSLC, M:MLC, T:3D TLC)
*:Product line: (E:Embedded, G:EverGreen, R:InnoRobust)
#:Product Generation: (empty, 0-9)
&:Product line: (empty, P:Plus)

Measurement Standard

EN 55032: 2012 / AC: 2013
CISPR 32: 2012
EN 61000-3-2: 2014
EN 61000-3-3: 2013
EN 55024: 2010 + A1: 2015
(IEC 61000-4-2: 2008; IEC 61000-4-3: 2006 + A1: 2007 + A2: 2010; IEC 61000-4-4: 2012;
IEC 61000-4-5: 2014; IEC 61000-4-6: 2013; IEC 61000-4-8: 2009; IEC 61000-4-11: 2004)

Measurement Facilities

Xindian Lab.: Compliance Certification Services Inc.
No.163-1, Jhongsheng Rd., Xindian Dist., New Taipei City, 23151 Taiwan.
Tel: +886-2-22170894 / Fax: +886-2-22171029

This device has been shown to be in compliance with and was tested in accordance with the measurement procedures specified in the Standards & Specifications listed above and as indicated in the measurement report number: T161208D02-E

Sam Hu / Assistant Manager

Date: December 12, 2016



VERIFICATION OF COMPLIANCE

This Verification of Compliance is hereby issued to the below named company. The test results of this report relate only to the tested sample identified in this report.

**Technical Standard: FCC Part 15 Class B
IC ICES-003**

General Information

Applicant: Innodisk Corporation
5F., No. 237, Sec. 1, Datong Rd., Xizhi Dist.,
New Taipei City 22161, Taiwan (R.O.C)

Product Description

EUT Description: mSATA mini
Brand Name: Innodisk
Model Number: mSATA mini 3\$*#-&
\$:Flash type: (S:SLC, I:iSLC, M:MLC, T:3D TLC)
*:Product line: (E:Embedded, G:EverGreen, R:InnoRobust)
#:Product Generation: (empty, 0~9)
&:Product line: (empty, P:Plus)

Measurement Facilities

Xindian Lab.: *Compliance Certification Services Inc.*
No.163-1, Jhongsheng Rd., Xindian Dist., New Taipei City, 23151 Taiwan.
Tel: +886-2-22170894 / Fax: +886-2-22171029

This device has been shown to be in compliance with and was tested in accordance with the measurement procedures specified in the Standards & Specifications listed above and as indicated in the measurement report number: T16L208D02-D

Sam Hu / Assistant Manager

Date: December 12, 2016