

SATADOM-SV

3ME3 Series (v2)

Customer: _____

Customer

Part

Number: _____

Innodisk

Part

Number: _____

Innodisk

Model Name: _____

Date: _____

Innodisk Approver	Customer Approver

**Total Solution For
Industrial Flash Storage**

Table of contents

LIST OF FIGURES	6
1. PRODUCT OVERVIEW	7
1.1 INTRODUCTION OF INNO DISK SATADOM-SV 3ME3 V2	7
1.2 PRODUCT VIEW AND MODELS	7
1.3 SATA INTERFACE.....	7
2. PRODUCT SPECIFICATIONS	8
2.1 CAPACITY AND DEVICE PARAMETERS.....	8
2.2 PERFORMANCE	8
2.3 ELECTRICAL SPECIFICATIONS	9
2.3.1 Power Requirement.....	9
2.3.2 Power Consumption	9
2.4 ENVIRONMENTAL SPECIFICATIONS	9
2.4.1 Temperature Ranges	9
2.4.2 Humidity.....	9
2.4.3 Shock and Vibration	10
2.4.4 Mean Time between Failures (MTBF)	10
2.5 CE AND FCC COMPATIBILITY	10
2.6 RoHS COMPLIANCE	10
2.7 RELIABILITY	11
2.8 TRANSFER MODE	11
2.9 PIN ASSIGNMENT	12
2.10 MECHANICAL DIMENSIONS.....	12
2.11 ASSEMBLY WEIGHT	13
2.12 SEEK TIME	13
2.13 HOT PLUG.....	13
2.14 NAND FLASH MEMORY.....	13
3. THEORY OF OPERATION.....	14
3.1 OVERVIEW.....	14
3.2 SATA III CONTROLLER	14
3.3 ERROR DETECTION AND CORRECTION.....	15
3.4 WEAR-LEVELING	15
3.5 BAD BLOCKS MANAGEMENT	15
3.6 POWER CYCLING	15
3.7 GARBAGE COLLECTION.....	15
4. INSTALLATION REQUIREMENTS	16
4.1 SATADOM-SV 3ME3 V2 PIN DIRECTIONS	16

4.2 ELECTRICAL CONNECTIONS FOR SATADOM-SV 3ME3 V2	16
4.3 DEVICE DRIVE	16
4.4 PIN8 VCC	16
4.5 POWER CABLE	17
5. PART NUMBER RULE	18

REVISION HISTORY

Revision	Description	Date
Preliminary	First Released	May, 2015
Rev 1.0	Official Released	October, 2015
Rev 1.1	Add Toshiba 15nm flash	January, 2016
Rev 1.2	Update Product Photo & Mechanical Drawing	April, 2024

List of Tables

TABLE 1: DEVICE PARAMETERS	8
TABLE 2: PERFORMANCE	8
TABLE 3: INNODISK SATADOM-SV 3ME3 V2 POWER REQUIREMENT	9
TABLE 4: POWER CONSUMPTION	9
TABLE 5: TEMPERATURE RANGE FOR SATADOM-SV 3ME3 V2	9
TABLE 6: SHOCK/VIBRATION TESTING FOR SATADOM-SV 3ME3 V2	10
TABLE 7: SATADOM-SV 3ME3 V2 MTBF	10
TABLE 8: INNODISK SATADOM-SV 3ME3 V2 PIN ASSIGNMENT	12

List of Figures

FIGURE 1: INNODISK SATADOM-SV 3ME3 V2	7
FIGURE 2: INNODISK SATADOM-SV 3ME3 V2 BLOCK DIAGRAM	14
FIGURE 3: SIGNAL SEGMENT AND POWER SEGMENT	16

1. Product Overview

1.1 Introduction of InnoDisk SATADOM-SV 3ME3 V2

Innodisk Serial ATA Disk on Module (SATADOM) supports SATA III standard (6.0Gb/s) interface with excellent performance, and SATADOM-SV 3ME3 V2 is designed as the smallest form factor size that could enhance compatibility with various design applications. The innovative Pin8 uses the SATA connector itself as a power supply to drive the device without external cables. It could be connected directly to the SATA on-board socket on customers' system without additional power cable. Besides, the booting time for operation and the power consumption is less than hard disk drive (HDD), and can work under harsh environment compile with ATA protocol, no additional drives are required, and the SSD can be configured as a boot device or data storage device.

1.2 Product View and Models

Innodisk SATADOM-SV 3ME3 V2 is available in follow capacities within MLC flash ICs.

[SATADOM-SV 3ME3 V2 8GB](#)

[SATADOM-SV 3ME3 V2 16GB](#)

[SATADOM-SV 3ME3 V2 32GB](#)

[SATADOM-SV 3ME3 V2 64GB](#)

[SATADOM-SV 3ME3 V2 128GB](#)



Figure 1: Innodisk SATADOM-SV 3ME3 V2

1.3 SATA Interface

Innodisk SATADOM-SV 3ME3 V2 supports SATA III interface, and compliant with SATA I and SATA II.

2. Product Specifications

2.1 Capacity and Device Parameters

SATADOM-SV 3ME3 V2 device parameters are shown in Table 1.

Table 1: Device parameters

Capacity	LBA	Cylinders	Heads	Sectors	User Capacity(MB)
8GB	15649200	15525	16	63	7,641
16GB	31277232	16383	16	63	15,272
32GB	62533296	16383	16	63	30,533
64GB	125045424	16383	16	63	61,057
128GB	250069680	16383	16	63	122,104

2.2 Performance

Burst Transfer Rate: 6.0Gbps

Table 2: Performance

Capacity		8GB	16GB	32GB	64GB	128GB
Toshiba A19nm MLC	Sequential* Read (max.)	100 MB/s	100 MB/s	100 MB/s	200 MB/s	200 MB/s
	Sequential* Write (max.)	20 MB/s	35 MB/s	40 MB/s	70 MB/s	80 MB/s
	4KB Random** Read (QD32)	3,800 IOPS	5,500 IOPS	5,500 IOPS	8,000 IOPS	7,300 IOPS
	4KB Random** Write (QD32)	4,800 IOPS	9,300 IOPS	9,300 IOPS	14,000 IOPS	15,400 IOPS

Capacity		8GB	16GB	32GB	64GB	128GB
Toshiba 15nm MLC	Sequential* Read (max.)	100 MB/s	100 MB/s	100 MB/s	210 MB/s	210 MB/s
	Sequential* Write (max.)	20 MB/s	20 MB/s	40 MB/s	75 MB/s	80 MB/s

4KB Random** Read (QD32)	3700 IOPS	3700 IOPS	4800 IOPS	7100 IOPS	7100 IOPS
4KB Random** Write (QD32)	5100 IOPS	5100 IOPS	9800 IOPS	13300 IOPS	133000 IOPS

Note: the information is based on CrystalDiskMark 3.01 with file size 1000MB test patent

2.3 Electrical Specifications

2.3.1 Power Requirement

Table 3: Innodisk SATADOM-SV 3ME3 V2 Power Requirement

Item	Symbol	Rating	Unit
Input voltage	V _{IN}	+5 DC +- 5%	V

2.3.2 Power Consumption

Table 4: Power Consumption

Mode	Power Consumption (mA)
Read	110 (max.)
Write	125 (max.)
Idle	90 (max.)
Pin 7/ Pin8 VCC Initial*	1000(max.)

Target: 32GB SATADOM-SV 3ME3 V2

***To design in Pin7/8 VCC on motherboard, 5V with 1A power supply is requested.**

2.4 Environmental Specifications

2.4.1 Temperature Ranges

Table 5: Temperature range for SATADOM-SV 3ME3 V2

Temperature	Range
Operating	Standard Grade: 0°C to +70°C
	Industrial Grade: -40°C to +85°C
Storage	-55°C to +95°C

2.4.2 Humidity

Relative Humidity: 10-95%, non-condensing

2.4.3 Shock and Vibration

Table 6: Shock/Vibration Testing for SATADOM-SV 3ME3 V2

Reliability	Test Conditions	Reference Standards
Vibration	7 Hz to 2K Hz, 20G, 3 axes	IEC 60068-2-6
Mechanical Shock	Duration: 0.5ms, 1500 G, 3 axes	IEC 60068-2-27

2.4.4 Mean Time between Failures (MTBF)

Table 7 summarizes the MTBF prediction results for various SATADOM-SV 3ME3 V2 configurations. The analysis was performed using a RAM Commander™ failure rate prediction.

- **Failure Rate:** The total number of failures within an item population, divided by the total number of life units expended by that population, during a particular measurement interval under stated condition.
- **Mean Time between Failures (MTBF):** A basic measure of reliability for repairable items: The mean number of life units during which all parts of the item perform within their specified limits, during a particular measurement interval under stated conditions.

Table 7: SATADOM-SV 3ME3 V2 MTBF

Product	Condition	MTBF (Hours)
Innodisk SATADOM-SV 3ME3 V2	Telcordia SR-332 GB, 25°C	>3,000,000

2.5 CE and FCC Compatibility

SATADOM-SV 3ME3 V2 conforms to CE and FCC requirements.

2.6 RoHS Compliance

SATADOM-SV 3ME3 V2 is fully compliant with RoHS directive.

2.7 Reliability

Parameter	Value
Read Cycles	Unlimited Read Cycles
Wear-Leveling Algorithm	Support
Bad Blocks Management	Support
Error Correct Code	Support
iData Guard	Support
Thermal Sensor	WT only
Flash endurance	3,000 P/E cycles
TBW* (Total Bytes Written)	
8GB	2.32
16GB	4.64
32GB	9.28
64GB	18.56
128GB	37.12
* Total bytes written is based on JEDEC 218 (Solid-State Drive Requirements and Endurance Test Method)	
** Lifespan is calculated by device written per day	

2.8 Transfer Mode

SATADOM-SV 3ME3 V2 support following transfer mode:

Serial ATA I 1.5Gbps

Serial ATA II 3.0Gbps

Serial ATA III 6.0Gbps

2.9 Pin Assignment

Innodisk SATADOM-SV 3ME3 V2 uses a standard SATA pin-out. See Table 8 for SATADOM-SV 3ME3 V2 pin assignment.

Table 8: Innodisk SATADOM-SV 3ME3 V2 Pin Assignment

Name	Type	Description
Pin 0	GND	Shielding
Pin 1	GND	Shielding
Pin 2	A+	Differential signal to A
Pin 3	A-	Differential signal to A-
Pin 4	GND	Shielding
Pin 5	B-	Differential signal to B-
Pin 6	B+	Differential signal to B
Pin 7	GND/	Shielding/ +5V Power*
Pin 8	VCC	+5V Power

* SATADOM-SV 3ME3 V2 default power supply through pin 8 or extra power cable.

Pin 7 power supply as an optional function with separated PN end of B.

2.10 Mechanical Dimensions

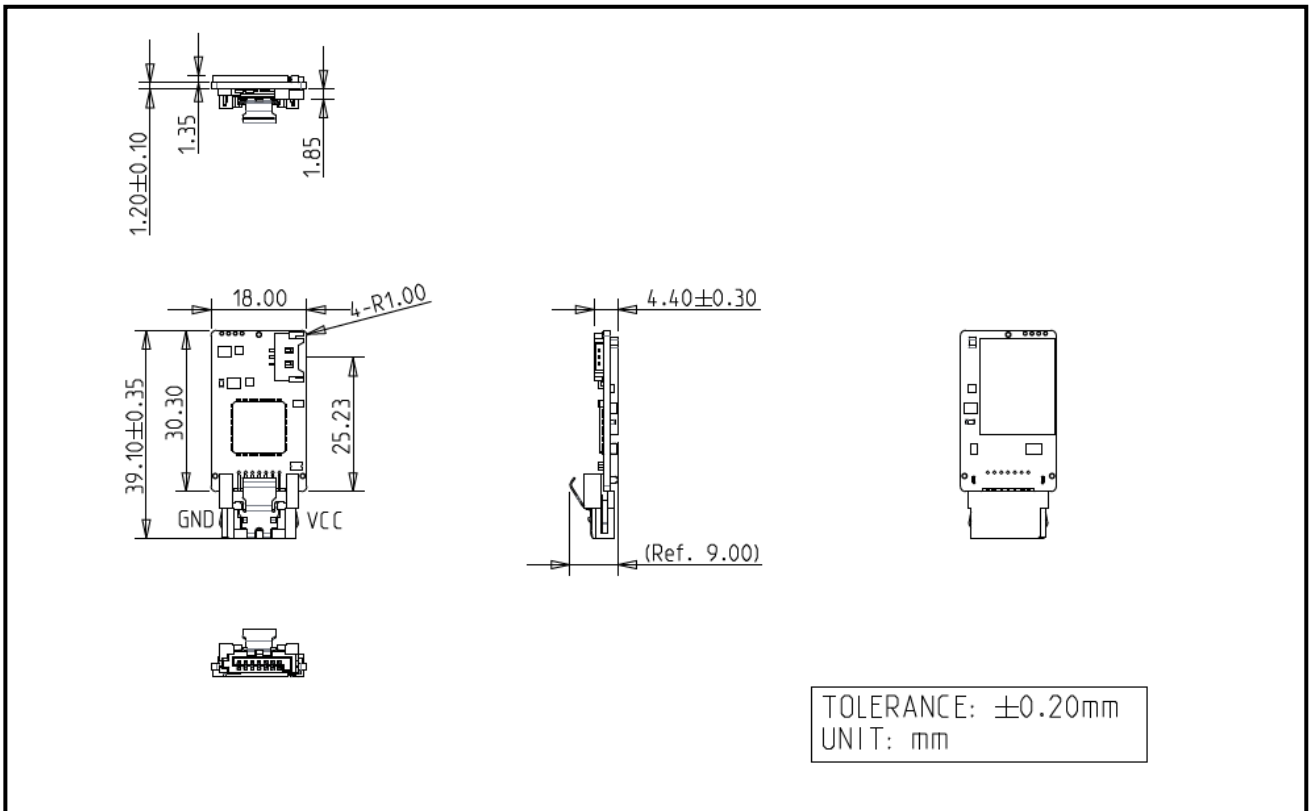

2.11 Assembly Weight

An Innodisk SATADOM-SV 3ME3 V2 within flash ICs, 32GB's weight is 7 grams approximately.

2.12 Seek Time

Innodisk SATADOM-SV 3ME3 V2 is not a magnetic rotating design. There is no seek or rotational latency required.

2.13 Hot Plug

The SSD support hot plug function and can be removed or plugged-in during operation. User has to avoid hot plugging the SSD which is configured as boot device and installed operation system.

Surprise hot plug : The insertion of a SATA device into a backplane (combine signal and power) that has power present. The device powers up and initiates an OOB sequence.

Surprise hot removal: The removal of a SATA device from a powered backplane, without first being placed in a quiescent state.

2.14 NAND Flash Memory

Innodisk SATADOM-SV 3ME3 V2 uses Multi Level Cell (MLC) NAND flash memory, which is non-volatility, high reliability and high speed memory storage. Each cell stores 2 bits or holds four states per cell. Read or Write data to flash memory for SSD is control by microprocessor.

3. Theory of Operation

3.1 Overview

Figure 2 shows the operation of Innodisk SATADOM-SV 3ME3 V2 from the system level, including the major hardware blocks.

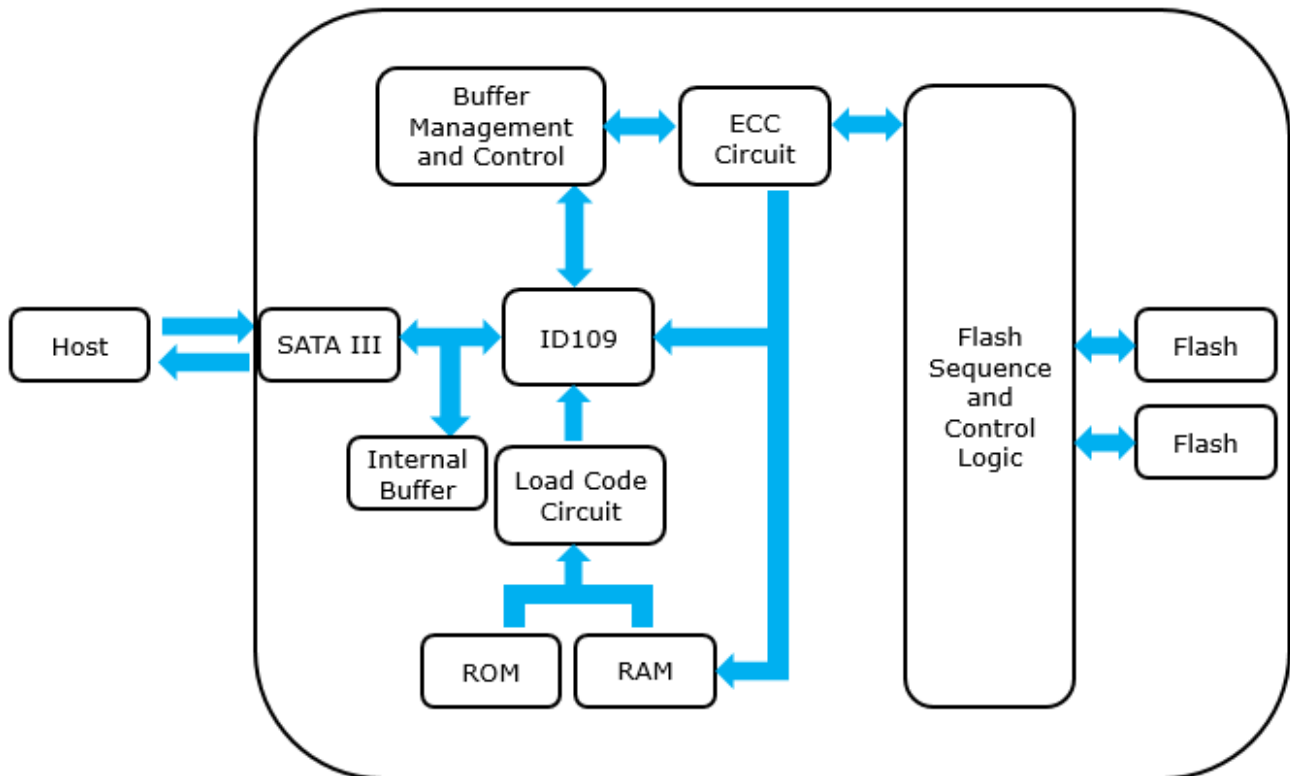

Figure 2: Innodisk SATADOM-SV 3ME3 V2 Block Diagram

Innodisk SATADOM-SV 3ME3 V2 integrates a SATA III controller and NAND flash memories. Communication with the host occurs through the host interface, using the standard ATA protocol. Communication with the flash device(s) occurs through the flash interface.

3.2 SATA III Controller

Innodisk SATADOM-SV 3ME3 V2 is designed with ID 109, a SATA III 6.0Gbps (Gen. 3) controller. The Serial ATA physical, link and transport layers are compliant with Serial ATA Gen 1, Gen 2 and Gen 3 specification (Gen 3 supports 1.5Gbps/3.0Gbps/6.0Gbps data rate). The controller has 2 channels for flash interface.

3.3 Error Detection and Correction

Highly sophisticated Error Correction Code algorithms are implemented. The ECC unit consists of the Parity Unit (parity-byte generation) and the Syndrome Unit (syndrome-byte computation). This unit implements an algorithm that can correct 40 bits per 1024 bytes in an ECC block. Code-byte generation during write operations, as well as error detection during read operation, is implemented on the fly without any speed penalties.

3.4 Wear-Leveling

Flash memory can be erased within a limited number of times. This number is called the **erase cycle limit** or **write endurance limit** and is defined by the flash array vendor. The erase cycle limit applies to each individual erase block in the flash device.

Innodisk SATADOM-SV 3ME3 V2 uses a static wear-leveling algorithm to ensure that consecutive writes of a specific sector are not written physically to the same page/block in the flash. This spreads flash media usage evenly across all pages, thereby extending flash lifetime.

3.5 Bad Blocks Management

Bad Blocks are blocks that contain one or more invalid bits whose reliability are not guaranteed. The Bad Blocks may be presented while the SSD is shipped, or may develop during the life time of the SSD. When the Bad Blocks is detected, it will be flagged, and not be used anymore. The SSD implement Bad Blocks management, Bad Blocks replacement, Error Correct Code to avoid data error occurred. The functions will be enabled automatically to transfer data from Bad Blocks to spare blocks, and correct error bit.

3.6 Power Cycling

Innodisk's power cycling management is a comprehensive data protection mechanism that functions before and after a sudden power outage to SSD. Low-power detection terminates data writing before an abnormal power-off, while table-remapping after power-on deletes corrupt data and maintains data integrity. Innodisk's power cycling provides effective power cycling management, preventing data stored in flash from degrading with use.

3.7 Garbage Collection

Garbage collection is used to maintain data consistency and perform continual data cleansing on SSDs. It runs as a background process, freeing up valuable controller resources while sorting good

data into available blocks, and deleting bad blocks. It also significantly reduces write operations to the drive, thereby increasing the SSD's speed and lifespan.

4. Installation Requirements

4.1 SATADOM-SV 3ME3 V2 Pin Directions

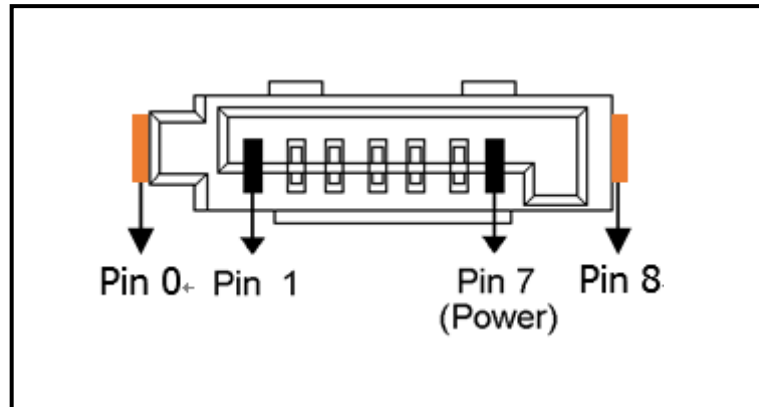

* SATADOM-SV 3ME3 V2 default power supply through pin 8 or extra power cable.

Pin 7 power supply as an optional function with separate PN end of B.

Figure 3: Signal Segment and Power Segment

4.2 Electrical Connections for SATADOM-SV 3ME3 V2

A Serial ATA device may be either directly connected to a host or connected to a host through a cable. For connection via cable, the cable should be no longer than 1meter. The SATA interface has a separate connector for the power supply. Please refer to the pin description for further details.

4.3 Device Drive

No additional device drives are required. The Innodisk SATADOM-SV 3ME3 V2 can be configured as a boot device.

4.4 Pin8 VCC

SATADOM-SV 3ME3 V2 series with Pin8 VCC, it is defined Pin8 as VCC on the SATA connector. Thus the power would come from SATA connector Pin8 VCC. Customers DO NOT have to use the power cable for power supply. Such a wireless design of SATADOM-SV 3ME3 V2 series with Pin8 VCC brings more convenience to customers' system. The followings are the points customers have to be careful of while designing in SATADOM-SV 3ME3 V2 series with Pin8 VCC.

When customers use SATADOM with Pin8 VCC and the host SATA socket does not have power on Pin8, external power must be provided to the SATADOM from the 3pin connector on the side.

To have the advantages of SATADOM-SV 3ME3 V2 series with Pin8 VCC, and to avoid any potential damage to customers' board designed with VCC power supply, Innodisk suggests that customers MUST design their board with a fuse which should be designed before the SATA socket Pin8 VCC. In other words, customers are suggested NOT TO layout 5V VCC to SATA socket on board directly. A circuit diagram example to explain this is shown as below.

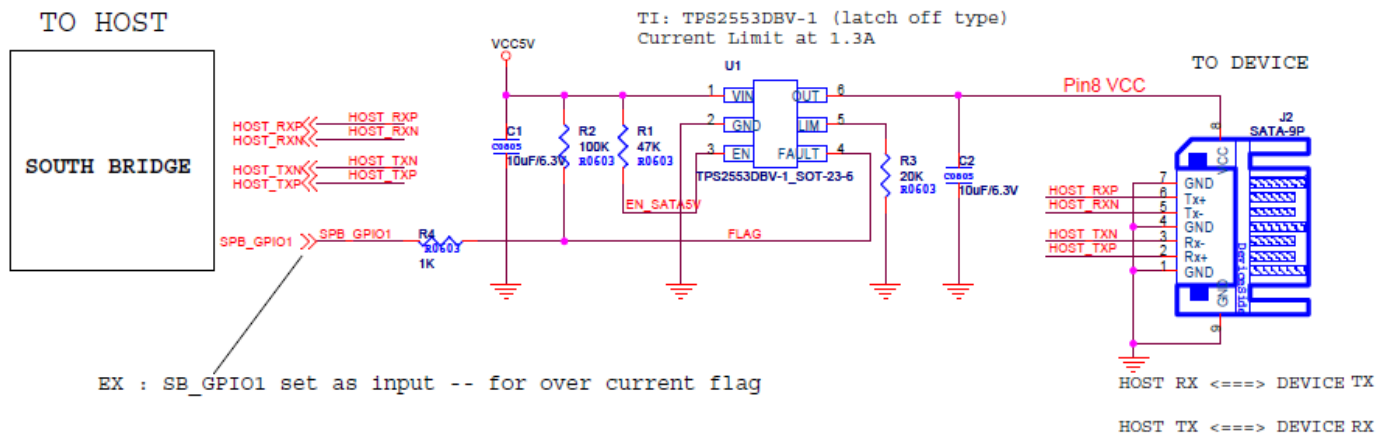

4.5 Power cable

A power cable is shipped with each SATADOM product, which has standard 4pins power connector and special 3 pins power connector for SATADOM. The male and female power connector of SATADOM have foolproof design to avoid misconnection, please check it before power on.

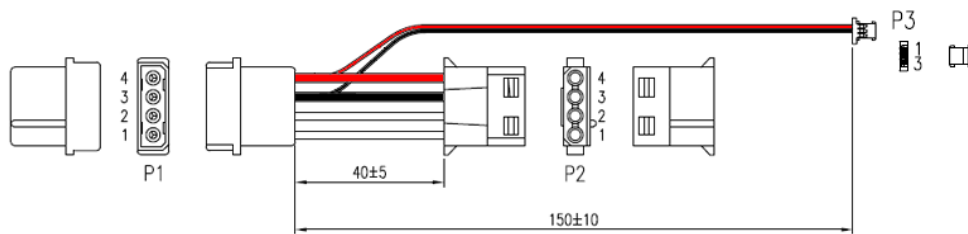

5. Part Number Rule

CODE	1	2	3	4	5	6	7	8	9	10	11	12	13	14	15	16	17	18	19	20	21
	D	E	S	S	V	-	3	2	G	D	0	9	S	C	1	S	C	A	X	X	X
Definition																					
Code 1st (Disk)											Code 14th (Operation Temperature)										
D : Disk											C: Standard Grade (0°C~ +70°C)										
Code 2nd (Feature set)											W: Industrial Grade (-40°C~ +85°C)										
E : Embedded series											Code 15th (Internal control)										
Code 3rd ~5th (Form factor)											1~9: TSOP PCB version.										
SSV: SATADOM-SV											A~Z: BGA PCB version (64GB and 128GB)										
Code 7th ~9th (Capacity)											Code 16th (Channel of data transfer)										
08G:8GB 16G:16GB 32G: 32GB 64G:64GB											S: Single Channel										
A28: 128GB											D: Dual Channels										
Code 10th ~12th (Controller)											Code 17th (Flash Type)										
D09: ID109											C: Toshiba MLC										
Code 13th (Flash mode)											Code 18th (pin7 type)										
S: Synchronous flash (Toshiba A19nm)											A: Pin8 version / Standard version										
B: Synchronous flash (Toshiba 15nm)											B: Pin8 & Pin7 version										
Code 19th~21st (Customize code)																					

Appendix

CE/FCC

International Standards Laboratory http://www.isl.com.tw

International Standards Laboratory http://www.isl.com.tw

International Standards Laboratory http://www.isl.com.tw

Certificate

Issue Date: August 6, 2015
Ref. Report No. ISL-15LE349CE

Product Name : SATADOM-SV
Model(s) : SATADOM-SV 3\$*#-&
(\$:Flash type: (S:SLC,I:iSLC,M:MLC);
*:Product line: (E:Embedded, G:EverGreen, R:InnoRobust);
#:Controller: (empty:106/107/167/170, 2:201/ 202, 3:108/109);
&:Product feature: (P:with DRAM, empty:without DRAM))
Responsible Party : Innodisk Corporation
Address : 5F.No.237, Sec. 1, Datong Rd., Xizhi Dist., New Taipei City 221,
Taiwan (R.O.C.)

We, **International Standards Laboratory**, hereby certify that:

The device bearing the trade name and model specified above has been shown to comply with the applicable technical standards as indicated in the measurement report and was tested in accordance with the measurement procedures specified in European Council Directive- EMC Directive 2004/108/EC. The device was passed the test performed according to :



Standards:

EN 55022: 2010+AC2011 and CISPR 22: 2008 (modified)
EN 61000-3-2: 2006+A1:2009 +A2:2009 and IEC 61000-3-2: 2005+A1:2008 +A2:2009
EN 61000-3-3: 2013 and IEC 61000-3-3: 2013
EN 55024: 2010 and CISPR 24: 2010
EN 61000-4-2: 2009 and IEC 61000-4-2: 2008
EN 61000-4-3: 2006+A1: 2008 +A2: 2010 and
IEC 61000-4-3:2006+A1: 2007+A2: 2010
EN 61000-4-4:2012 and IEC 61000-4-4:2012

I attest to the accuracy of data and all measurements reported herein were performed by me or were made under my supervision and are correct to the best of my knowledge and belief. I assume full responsibility for the completeness of these measurements and vouch for the qualifications of all persons taking them.

International Standards Laboratory

Jim Chu

Jim Chu / Director

Hsi-Chih LAB:
No. 65, Gu Dai Keng Street, Hsi-Chih Dist.,
New Taipei City 221, Taiwan
Tel: 886-2-2646-2550; Fax: 886-2-2646-4641

Lung-Tan LAB:
No. 120, Lane 180, Hsin Ho Rd., Lung-Tan Dist.,
Tao Yuan City 325, Taiwan
Tel: 886-3-407-1718; Fax: 886-3-407-1738



Certificate

Issue Date: August 6, 2015
 Ref. Report No. ISL-15LE349FB

Product Name : SATADOM-SV
 Model(s) : SATADOM-SV 3\$*#-&
 (\$.Flash type: (S:SLC,I:iSLC,M:MLC);
 *:Product line: (E:Embedded, G:EverGreen, R:InnoRobust);
 #:Controller: (empty:106/107/167/170, 2:201/ 202, 3:108/109);
 &:Product feature: (P:with DRAM, empty:without DRAM))

Applicant : Innodisk Corporation
 Address : 5F.No.237, Sec. 1, Datong Rd., Xizhi Dist., New Taipei City 221,
 Taiwan (R.O.C.)

We, **International Standards Laboratory**, hereby certify that:

The device bearing the trade name and model specified above has been shown to comply with the applicable technical standards as indicated in the measurement report and was tested in accordance with the measurement procedures specified. (refer to Test Report if any modifications were made for compliance).



Standards:

FCC CFR Title 47 Part 15 Subpart B: 2014- Section 15.107 and 15.109
 ANSI C63.4-2009
 Industry Canada Interference-Causing Equipment Standard ICES-003 Issue 5: 2012

Class B

I attest to the accuracy of data and all measurements reported herein were performed by me or were made under my supervision and are correct to the best of my knowledge and belief. I assume full responsibility for the completeness of these measurements and vouch for the qualifications of all persons taking them.

International Standards Laboratory

Jim Chu
 Jim Chu / Director

Hsi-Chih LAB:

No. 65, Gu Dai Keng Street, Hsi-Chih Dist.,
 New Taipei City 221, Taiwan
 Tel: 886-2-2646-2550; Fax: 886-2-2646-4641



Lung-Tan LAB:

No. 120, Lane 180, Hsin Ho Rd., Lung-Tan Dist.,
 Tao Yuan City 325, Taiwan
 Tel: 886-3-407-1718; Fax: 886-3407-1738



innodisk

宜鼎國際股份有限公司 Innodisk Corporation

Tel:(02)2696-3000 Fax:(02)2696-2000 Internet: <http://www.innodisk.com/>

REACH Declaration of Conformity

Manufacturer Products: All Innodisk EM Flash and Dram products

1. 宜鼎國際股份有限公司（以下稱本公司）特此保證此售予貴公司之產品，皆符合歐盟化學品法案(Registration, Evaluation and Authorization of Chemicals; REACH)之規定 (<http://www.echa.europa.eu/de/candidate-list-table> **last updated: 16/12/2013**)。所提供之產品包含：(1) 產品或產品所使用到的所有原物料；(2) 包裝材料；(3) 設計、生產及重工過程中所使用到的所有原物料。

We Innodisk Corporation hereby declare that our products are in compliance with the requirements according to the REACH Regulation

(<http://www.echa.europa.eu/de/candidate-list-table> **last updated: 16/12/2013**).

Products include : 1) Product and raw material used by the product ; 2) Packaging material ; 3) Raw material used in the process of design, production and rework

2. 本公司同意因本保證書或與本保證書相關事宜有所爭議時，雙方宜友好協商，達成協議。

InnoDisk Corporation agrees that both parties shall settle any dispute arising from or in connection with this Declaration of Conformity by friendly negotiations.

立 保 證 書 人 (Guarantor)

Company name 公司名稱：InnoDisk Corporation 宜鼎國際股份有限公司

Address：9F, No. 100, Sec.1 Xintai 5th Rd., Xizhi Dist., New Taipei City 221, Taiwan

Company Representative 公司代表人：Richard Lee 李鐘亮

Company Representative Title 公司代表人職稱：CEO 執行長

Date 日期：2014 / 03 / 18



RoHS 自我宣告書(RoHS Declaration of Conformity)**Manufacturer Product: All Innodisk EM Flash and Dram products**

宜鼎國際股份有限公司（以下稱本公司）特此保證售予貴公司之所有產品，皆符合歐盟 2011/65/EU 關於 RoHS 之規範要求。

InnoDisk Corporation declares that all products sold to the company, are complied with European Union RoHS Directive (2011/65/EU) requirement

一、本公司同意因本保證書或與本保證書相關事宜有所爭議時，雙方宜友好協商，達成協議。

InnoDisk Corporation agrees that both parties shall settle any dispute arising from or in connection with this Declaration of Conformity by friendly negotiations.

Name of hazardous substance	Limited of RoHS ppm (mg/kg)
Cd	< 100 ppm
Pb	< 1000 ppm
Hg	< 1000 ppm
Chromium VI (Cr+6)	< 1000 ppm
Polybromodiphenyl ether (PBDE)	< 1000 ppm
Polybrominated Biphenyls (PBB)	< 1000 ppm

立 保 證 書 人

Company name 公司名稱：InnoDisk Corporation 宜鼎國際股份有限公司

Company Representative 公司代表人：Richard Lee 李鐘亮

Company Representative Title 公司代表人職稱：CEO 執行長

Date 日期：2013 / 09 / 25

