



2023 – 2024 Edition

INTELLIGENT TRANSPORTATION SOLUTIONS

iBASE
www.ibase.com.tw



Table of Contents

About IBASE

■ About IBASE	3-5
■ IBASE Intelligent Transportation Solutions	6-7

Railway Computer System

MPT-500R	EN50155/EN45545 Certified Intel® Atom® Processor X Series Railway Computer System with M12 Connection and Dual WWAN	8
MPT-1000R	EN50155/EN45545 Certified Intel® Atom® x7-E3950 Processor Railway Computer System with M12 Connection and Dual WWAN	9
MPT-3000RP	EN50155/EN45545 Certified Intel® Atom® Processor E3845 IP67 Waterproof Railway Computer System with M12 Connection and WWAN Redundancy	10
MPT-3000R	EN50155/EN45545 Certified Intel® Atom® Processor E3845 Railway Computer System with M12 Connection and WWAN Redundancy	11
NEW MPT-3100R	EN50155/EN45545 Certified Intel® Atom® x6000E Series Processor Railway Computer System with M12 Connection and WWAN Redundancy	12
MPT-7000R	EN50155/EN45545 Certified 7th/6th Gen Intel® Core™ Processor Railway Computer System with M12 Connection and WWAN Redundancy	13
NEW MPT-7100R	EN50155/EN45545 Certified 13th Gen Intel® Core™ Processor Railway Computer System with M12 Connection and WWAN Redundancy	14
MPT-8000R	EN50155/EN45545 Certified 10th Gen Intel® Core™ Processor Railway Computer System with M12 Connection and Dual WWAN	15

In-Vehicle Computer System

MPT-1000V	E-mark Certified Intel® Atom® x7-E3950 Processor In-Vehicle Computer System with Dual WWAN	16
MPT-3000V	E-mark Certified Intel® Atom® Processor E3845 In-Vehicle Computer System with WWAN Redundancy	17
NEW MPT-3100V	E-Mark Certified Intel® Atom® x6000E Series Processor In-Vehicle Computer System with WWAN Redundancy	18
MPT-7000V	E-mark Certified 7th/6th Gen Intel® Core™ Processor In-Vehicle Computer System with WWAN Redundancy	19
NEW MPT-7100V	E-Mark Certified 13th Gen Intel® Core™ Processor In-Vehicle Computer System with WWAN Redundancy	20

All-in-One Bar-Type Panel PC

MRD286	Intel® Atom® x7-E3950 / Pentium® N4200 Processor All-in-One 28.6" Bar-Type Panel PC	21
--------	---	----

Railway Panel PC

MPPC1501PC	EN50155 Certified 15" Intel® Atom® x7-E3950 Processor Fanless Railway Panel PC	22
MPPC1201PC	EN50155 Certified 12.1" Intel® Atom® x6425E Series Processor Fanless Railway Panel PC	23
MPPC1001PC	EN50155 Certified 10.4" Intel® Atom® x7-E3950 Processor Fanless Railway Panel PC	24
BYTEM-123-PC	EN50155 Certified 12.1" Intel® Atom® Processor E3845 Fanless Railway Panel PC	25
BYTEM-103-PC	EN50155 Certified 10.4" Intel® Atom® Processor E3845 Fanless Railway Panel PC	26

Accessories

IDT-7104	4-Channel PCI Express® Power-over-Ethernet Interface Card	27
----------	---	----

About IBASE

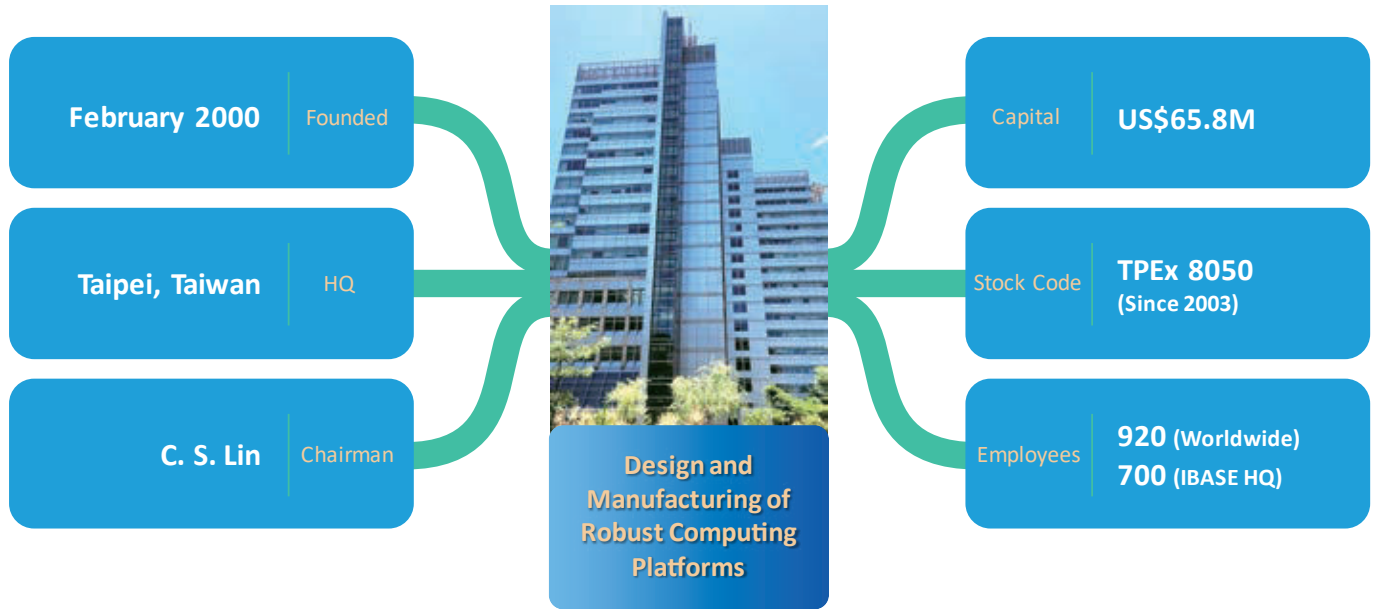

Company Profile

IBASE Technology specializes in the design and manufacture of robust industrial PC, products since its establishment in 2000. IBASE carries out manufacturing and quality control at its own facilities in Taiwan that are certified with ISO 9001, ISO 13485, ISO 14001 and ISO 27001 standards. Current offerings comprise x86 and RISC-based industrial motherboards, embedded systems, panel PCs, network appliances and digital signage players. The company is publicly listed in the Taipei Exchange (TPEX: 8050) and is now a leading global provider of innovative industrial and embedded computing solutions.



Core Competence

IBASE has three manufacturing sites in Taiwan, with two in New Taipei City and another one in Taoyuan City. We manufacture and implement strict quality control to supply excellent industrial computer products that are 100% made in Taiwan. In addition to off-the-shelf products, IBASE also specializes in OEM/ODM/JDM services, tailoring products to fully meet customers' expectations and the needs of various applications. With manufacturing and quality control capabilities recognized by major international companies, IBASE boasts of strong innovative R&D teams and flexible and timely products delivery.



Design⁺, Manufacture⁺, Service⁺

Set up to become a global leading provider of embedded board and system solutions, IBASE manufacturers and supplies cutting-edge products based on the latest technologies to match market demands. Our R&D and product management teams have the expertise to design and develop innovative products that meet customers' requirements and design specifications. We attach great importance to research and development, investing heavily in manpower and resources to continuously provide high-quality innovative products. IBASE is also committed to compliance with environmental policies by working to prevent pollution with non-use of banned or restricted substances in our production process and products, helping our customers respond to their environmental challenges.

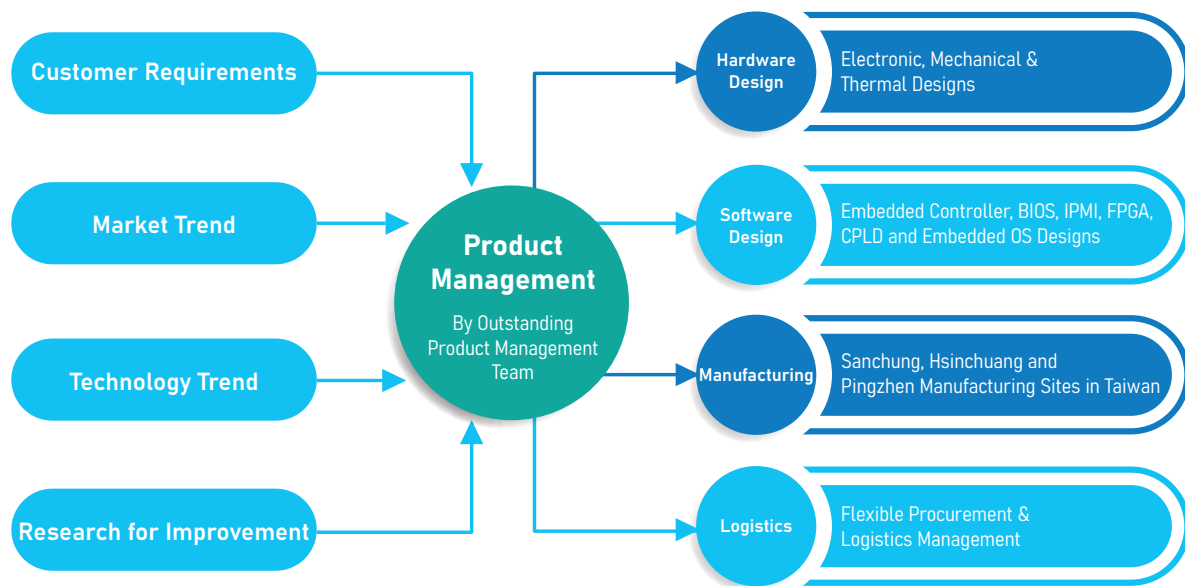

IBASE Manufacturing Sites

Design & Manufacturing in Taiwan

SANCHUNG

- Board Production
- Validation

3,124 m² / 945 Ping

HSINCHUANG

- System Assembly
- Validation

6,070 m² / 1,840 Ping

NEW

PINGZHEN

- Board Production
- System Assembly
- Validation

18,481 m² / 5,591 Ping

Total Size

297,891 Square-feet
(27,675 m² / 8,376 Ping)

Capacity

- SMT Line x 5
- DIP Assembly Line x 4
- System Assembly Line x 10
- Cleanroom x 2
- Burn-in Room x 13

PCBA
80K/month (In-house Production)
+ Outsourcing

System Assembly
50K/month (In-house Production)
+ Outsourcing

Certifications

ISO 9001 ISO 14001 ISO 13485 IAS ACCREDITED ISO 27001

CE FCC UL CCC RoHS REACH WEEE

Your Best Partner

IBASE is a worldwide leader in the manufacture of reliable and multi-functional computer system and industrial panel PC products. We offer a comprehensive range of intelligent transportation PC solutions, including EN50155/EN45545 and E-mark certified computers and panel PCs design for railway and in-vehicle applications. Featuring innovative technology, such as self-debug and self-protection control systems and high-definition passenger information systems, the products meet all transportation market demands. Deployed worldwide, IBASE's secure and energy-saving intelligent transportation solutions enable safe, comfortable and efficient travel for commuters.

Aside from developing standard products, IBASE provides ODM (Original Design Manufacturer) and JDM (Joint Design Manufacturer) services and customized product solutions. With our highly-qualified expert engineers, IBASE can tailor products that meet customers' application-specific needs, ensuring high quality, reliability and longevity and provide one-stop shopping services to our valued clients.

IBASE has partnered with Intel in product development to create embedded computing solutions with unprecedented levels of performance. We have built our reputation through dedication and commitment to deliver well-designed products and an outstanding level of customer service. To this day, IBASE continue to foster an unbreakable relationship with both customers and technology vendors, working hand-in-hand to form a lasting win-win partnership.



IBASE Intelligent Transportation Solutions



Intelligent transportation solutions offer effective traffic management and mobility management through continuous monitoring of traffic conditions, traffic flow control, and timely delivery of accurate road and traffic-related information to drivers and commuters. These solutions contribute to resolving road safety issues by empowering users with better information, enabling them to make safer and smarter use of transportation networks.

IBASE is a global leader in the manufacture of reliable and multi-functional computer systems and panel PC products. Our intelligent transportation solutions are designed with robust industrial-grade electronics to ensure road safety and are well-suited for harsh environments, providing uninterrupted operation with high reliability. We offer a comprehensive range of intelligent transportation PC solutions, including EN50155:2017 and E-mark certified computers and panel PCs designed for railway and in-vehicle applications. We also have a wide range of motherboards, embedded systems, and touch panel PCs from 4" to 21.5" for deployment in various intelligent transportation applications such as traffic information management, automatic fare collection, real-time parking management, passenger information system, and driver's console HMI.

Global Deployment of Secure and Energy-Saving Intelligent Transportation Solutions

IBASE's intelligent transportation solutions are deployed worldwide, providing safe, comfortable, and efficient travel for commuters. Our secure and energy-saving solutions are designed to meet the challenges of the transportation industry, ensuring reliable performance in harsh environments. With certifications such as EN50155/EN45545 and E-mark, our products are compliant with industry standards and regulations, ensuring high quality and reliability.

Customized Solutions to Meet Application-Specific Needs

In addition to our standard products, IBASE provides ODM (Original Design Manufacturer) and JDM (Joint Design Manufacturer) services, as well as customized product solutions. With a team of highly qualified expert engineers, we can tailor products to meet the specific needs of our customers' applications, delivering high quality, reliability, and longevity. Our one-stop shopping services provide convenience and efficiency to our valued clients, allowing them to find comprehensive solutions for their transportation needs.

Strategic Partnership with Intel for Unprecedented Performance

IBASE has established a strategic partnership with Intel in product development, leveraging their cutting-edge technology to create embedded computing solutions with unprecedented levels of performance. This partnership allows us to deliver products that are at the forefront of technological advancements, ensuring our customers stay ahead in the competitive transportation market.

Commitment to Customer Service and Lasting Win-Win Partnerships

IBASE has built its reputation through dedication and commitment to delivering well-designed products and outstanding customer service. We value our relationships with both customers and technology vendors and work hand-in-hand to form lasting win-win partnerships. Our customer-centric approach ensures that we understand our customers' needs and provide timely and efficient support, establishing IBASE as a trusted partner in the intelligent transportation industry.

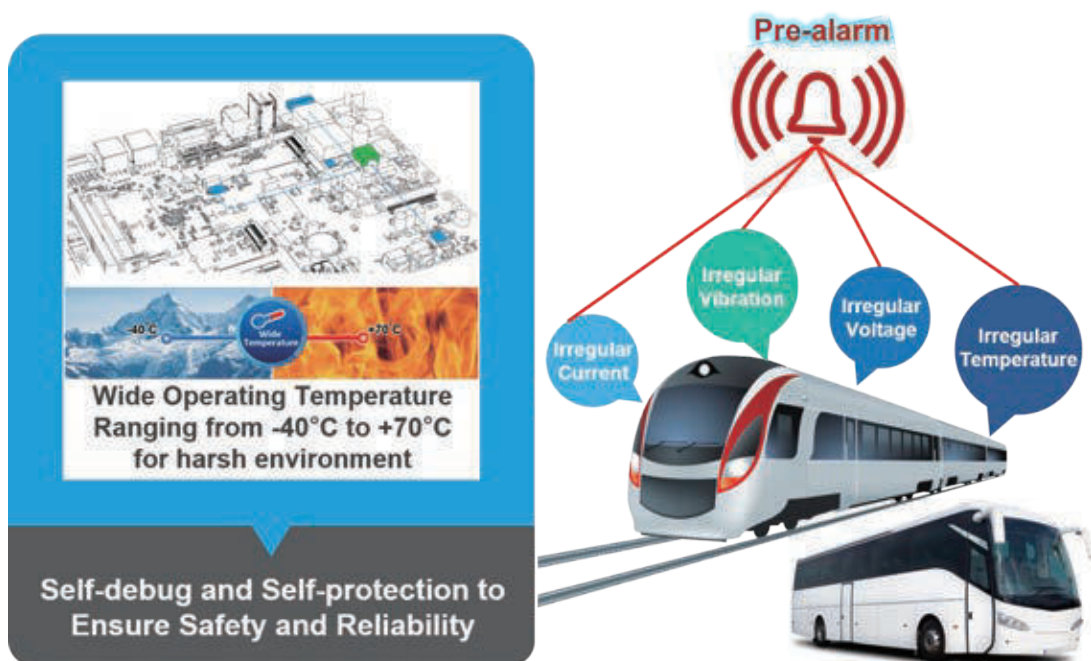



Features

- Intel® Atom® x6425RE/x6212RE processors
- EN50155 (2021) / EN45545-2 certified
- Fanless and ruggedized design
- Robust M12 connection for one 2.5G LAN, dual GbE LAN with PoE, dual USB
- Isolated USB, RS485 ports
- SIM socket with dual WWAN support
- Optional isolated CANbus thru Mini PCI-E card
- Wide-range operating temperature from -30°C to +70°C

Specifications

System Mainboard	MBT-501R
CPU Type	Intel® Atom® x6212RE/ x6425RE Processor
Processor Speed	Intel® Atom® x6212RE: 1.2GHz Intel® Atom® x6425RE: 1.90GHz
Memory	4GB/8GB LPDDR4 3200 on board
Front panel I/O	1x Recessed access fact-switch for system power 4x light-pipe for four status LED 1x USB type-C with DP 6x LED with each port for network status 2x USB3.2 Gen.1 type-A 2x external accessible SIM socket 3x M12 8-pin X-code for LAN (Two GbE LAN come with PoE and one 2.5G LAN) 1x M12 4-pin A-code for USB 1.1 1x M12 4-pin A-code for USB 2.0 1x 3.5mm audio connector for line output 1x 3.5mm audio connector for MIC input
Rear Panel External I/O	1x HDMI type-A 1x USB3.2 Gen.2 type-A 2x SMA antenna holes with cap 1x M3 screw hole for grounding connection 1x DSUB15 for 4x DO/4x DI and ground 1x DSUB9 for RS-232/485 1x DSUB9 for 2x RS485 isolated 1x M12 4-pin A-code for power input
Storage	1x 2280 M.2 M-key (PCI-E M.2 SSD) 1x 2.5" device bay for SSD or HDD. Default 2.5" 64G SSD
Expansion slots	1x mPCI-E full/half socket (PCI-E, USB 2.0) (supports SIM2) 1x 3042/52 M.2 B-key (4G/5G) (supports SIM1)
Power Supply	24V DC or 72V DC/110V DC
Construction	Aluminum
Chassis Color	Black
Mounting	Side mounting
Dimensions	240 (W) x 138 (D) x 93 (H) mm 9.4" (W) x 5.4" (D) x 3.7" (H)
Operating Temperature	SSD w/o PCI-E Card: -40°C ~70°C, up to 85°C for 10 minutes SSD w/ PCI-E Card: -40°C ~55°C, up to 70°C for 10 minutes HDD: -25°C ~55°C, up to 70°C for 10 minutes
Storage Temperature	-40°C ~ 85°C (-40°F~185°F)
Relative Humidity	10 ~ 95% @ 45°C, (non-condensing)
Vibration	Function: 1m/S ² , 5Hz~150Hz (EN 61373) Lifetime: 7.9m/S ² , 5Hz~150Hz (EN 61373)
Shock	50 m/S ² , 30 msec (EN61373)

Certified	EN50155: 2021 CE (EN62368/ EN55032/ EN55035)/ FCC Class-A EN45545-2
-----------	---

Ordering Information

MPT-500R	MPT-500R with MBT-501RX25, Intel® Atom® x6425RE processor, w/ 4GB RAM, 64G MLC SSD, 24V DC input
MPT-500RH	MPT-500RH with MBT-501RX25, Intel® Atom® x6425RE processor, w/ 4GB RAM, 64G MLC SSD, 72/110V DC input
MPT-500RHA	MPT-500RHA with MBT-501RX25A, Intel® Atom® x6425RE processor, w/ 8GB RAM, 64G MLC SSD, 72/110V DC input
MPT-500RE	MPT-500RE with MBT-501RX12, Intel® Atom® X6212RE processor, w/ 4GB RAM, 64G MLC SSD, 24V DC input

Dimensions

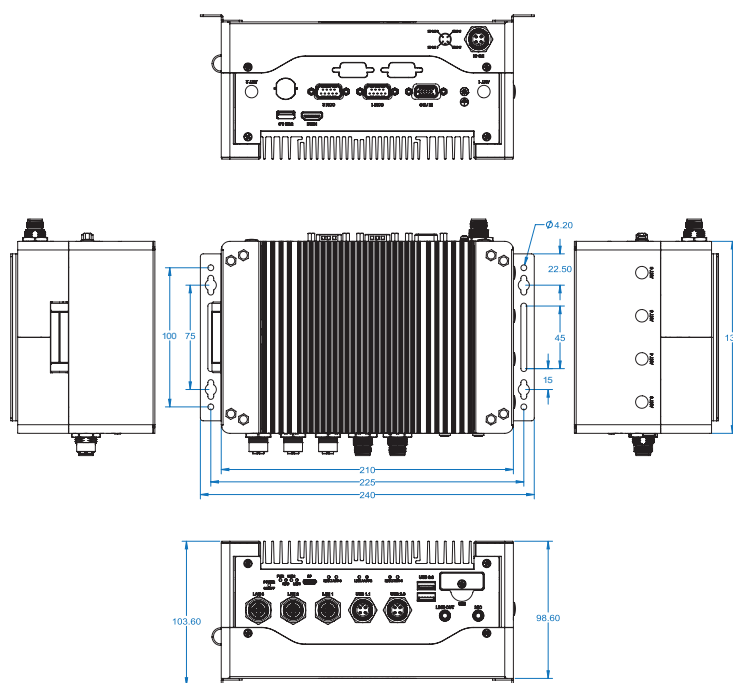

MPT-1000R

Railway Computer System

EN50155/EN45545 Certified Intel® Atom® x7-E3950 Processor Railway Computer System with M12 Connection and Dual WWAN



MPT-1000R VIDEO



Specifications

System Mainboard	MBT-1001R
CPU Type	Intel® Atom® x7-E3950 Processor
Processor Speed	1.6GHz , up to 2.0GHz
Memory	1x DDR3L SO-DIMM socket (horizontal type) with ECC support, default 4GB ECC
Front panel I/O	1x power reset button 1x DVI-D 2x M12 X-code GbE LAN, isolated 1x USB 2.0 type-A, isolated 1x M12 A-code USB 2.0 isolated 2x Audio jack for Line-in/out 5x LED indications, one is programmable 1x SIM card slot for dual micro SIM card 1x Expansion slots reset button
Rear Panel External I/O	1x 10-pin terminal block connector for - 2x insulated DO • Output type: Darlington transistor • Sink current: 500 mA for one channel @100% duty - Source current: 500 mA for one channel @100% duty cycle - Supply voltage: 5V~35V DC - Isolation voltage: 2500 VRMS - 6x insulated DI • Maximum input range: 24V, non-polarity • Digital logic levels: 0V~24V, non-polarity • Input high voltage: 5V~24V • Input low voltage: 0V~1.5V • Input resistance: 1.2k @ 0.5W Isolation voltage: 2500 VRMS - 1x DSUB9 for RS232/485, isolated - 1x DSUB9 for RS485, isolated 1x M12 4-pin D-code for 2 master CANbus, isolated 2x USB 2.0 type-A, isolated 1x M12 3-pin A-code for power input 1x Blade fuse
Storage	2x 2.5" device bay for SSD/HDD 1x mSATA via miniPCI-E slot (shared with one 2.5" device)
Expansion slots	1x miniPCI-E full/Half-size, supports mSATA 1x miniPCI-E full/Half-size, supports second SIM card shared with M.2 slot 1x M.2 B-key 30x42 with USB 2.0 and USB 3.0 signal only, supports 2x SIM cards
Power Supply	9V~32VDC, 1.5KV galvanic isolation protection
Construction	Matel
Chassis Color	Black
Mounting	Side mounting, rack mounting with optional bracket
Dimensions	340 (W) x 183.4 (D) x 67.6 (H) mm 13.3" (W) x 7.22" (D) x 2.66" (H)

Features

- EN50155 (2017) certified
- Fanless and ruggedized design
- Robust M12 connection for dual GbE, USB
- Onboard isolated CANbus
- SIM socket supports Dual WWAN
- Add on card slots reset function
- Quick accessible RTC battery

Operating Temperature	-40°C ~70°C, with SSD, not including add-on cards
Storage Temperature	-40°C ~ 85°C (-40°F~185°F)
Relative Humidity	10 ~ 95% @ 45°C, (non-condensing)
Vibration	Function: 1m/S2, 5Hz~150Hz (EN 61373) Lifetime: 7.9m/S2, 5Hz~150Hz (EN 61373)
Shock	50 m/S2, 30 msec (EN61373)
Certified	EN50155: 2017 CE (EN62368/ EN55032/ EN55025)/ FCC Class-A EN45545-2

Ordering Information

MPT-1000RM	MPT-1000R with MBT-1001R, Intel® Atom® x7-E3950 Processor, 4G DDR3L ECC RAM, 2x M12 GbE LAN, 24VDC(-25%~+30%), No OS, adaptor and storage
------------	---

Dimensions

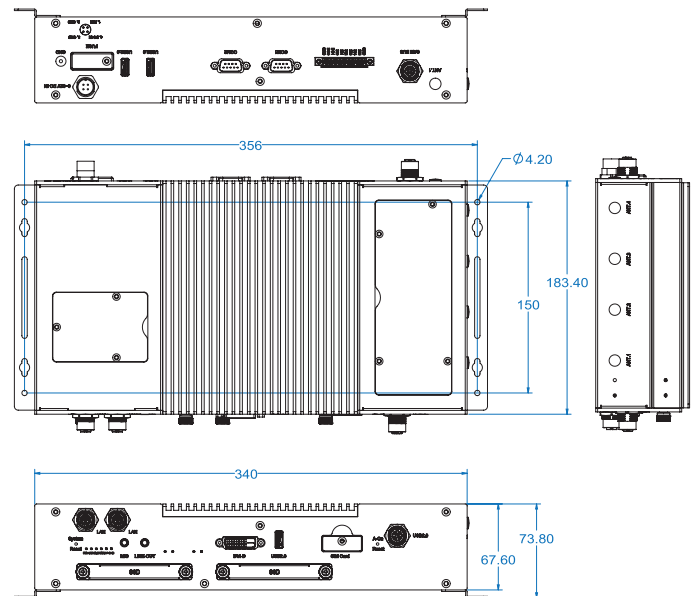



Features

- EN50155 (2017) certified and IP67 rated
- Fanless and ruggedized design
- Robust M12 connectors for dual GbE, USB and power input
- Dual SIM sockets support WWAN redundancy
- Rich I/O interfaces for wireless, SSD, GPS, WWAN
- Ignition power control
- Wide-range voltage GPIO interface



Ordering Information

MPT-3000RP	Intel® Atom® Processor E3845, 128G M.2 SSD, 4G DDR3LRAM, 9V~36VDC, totally IP67, No adaptor
------------	---

Dimensions

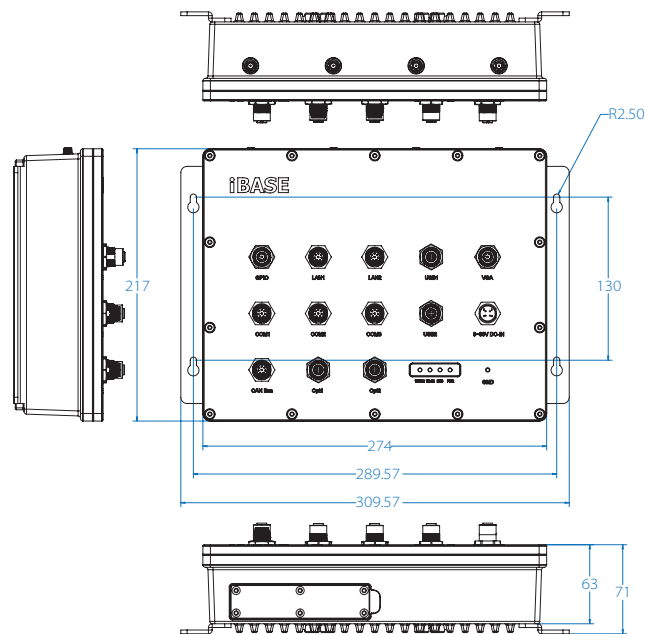

Specifications

System Mainboard	MBT-3001R
CPU Type	Intel® Atom® Processor E3845
Processor Speed	1.91GHz
Memory	2x 2GB DDR3L-1333 SO-DIMM (Dual Channel)
Front panel I/O	CFAST, 2.5" drive bay, 2x SIM sockets 2x M12 USB 2.0 4x antenna connectors 1x M12 VGA, 3x M12 COMs, 2x M12 GbE, 1x M12 power connection 1x M12 GPIO, 1x M12 CAN Bus Status LEDs
Rear Panel External I/O	N/A
Storage	2.5" drive bay for SSD & HDD M.2 SSD Storage
Expansion slots	1x Half-size Mini PCI-E socket (USB 2.0) 1x Full-size Mini PCI-E socket (USB 2.0 + PCI-E) 1x 2230 M.2 E-Key socket (USB 2.0 + PCI-E) 1x 3042 M.2 B-Key WWAN socket (USB 2.0) 1x 2280 M.2 M-Key SSD socket (SATA)
Power Supply	DC 9V~36V / 72V / 110V
Construction	Aluminum
Chassis Color	Black
Mounting	Wall Mount
Dimensions	270.0 (W) x 63.0 (D) x 210.0 (H) mm 10.62" (W) x 2.48" (D) x 8.26" (H)
Operating Temperature	SSD: -40°C ~ 70°C (-40°F~158°F)
Storage Temperature	-40°C ~ 85°C (-40°F~185°F)
Relative Humidity	10 ~ 95% RH @ 45°C (non-condensing)
Vibration	Function: 1 m/s ² , 5Hz ~ 150 Hz (EN 61373) Lifetime: 5.72 m/s ² , 5Hz ~ 150 Hz (EN 61373)
Shock	50 m/s ² , 30 msec (EN 61373)
Certified	EN50155: 2017, EN50153:2014 EN50121-3-2:2015, CE Class-A, FCC Class-A, EN45545



Features

- EN50155 (2021) certified
- Fanless and ruggedized design
- Robust M12 connection for dual GbE, USB and power input
- Dual SIM sockets support WWAN redundancy
- Removable 2.5" device bay and CFast socket
- Rich I/O interfaces for wireless, SSD, GPS, WWAN and add-on card expansion
- Ignition power control
- Wide-range voltage GPIO interface

Specifications

System Mainboard	MBT-3001R
CPU Type	Intel® Atom® Processor E3845
Processor Speed	1.91GHz
Memory	2x 2GB DDR3L-1333 SO-DIMM (Dual Channel)
Front Panel External I/O	CFast, 2.5" device bay, 2nd Mic-In & Line-Out 2x SIM sockets, 1x USB 3.0, 1x USB 2.0, Reset button Status LEDs, 4x antenna connectors
Rear Panel External I/O	DVI-D, VGA, 3x COMs (one with RS422/485 options) 2x M12 GbE, 2x M12 USB 2.0, M12 power connection 1st Mic-In & Line-Out, GPIO, GbE status LEDs
Storage	2.5" device bay for SSD & HDD
Expansion slots	1x Half-size Mini PCI-E socket (USB 2.0) 1x Full-size Mini PCI-E socket (USB 2.0 + PCI-E) 1x 2230 M.2 E-Key socket (USB 2.0 + PCI-E) 1x 3042 M.2 B-Key WWAN socket (USB 2.0) 1x 2280 M.2 M-Key SSD socket (SATA)
Power Supply	DC 9V~36V / 72V / 110V
Construction	Aluminum
Chassis Color	Black
Mounting	Custom mounting rail
Dimensions	256.0 (W) x 182.0 (D) x 68.0 (H) mm 10.08" (W) x 7.17" (D) x 2.68" (H)
Operating Temperature	SSD: -40°C ~ 70°C (-40°F~158°F) HDD: -20°C ~ 50°C (-4°F~122°F)
Storage Temperature	-40°C ~ 85°C (-40°F~185°F)
Relative Humidity	10 ~ 95% RH @ 45°C (non-condensing)
Vibration	Function: 1 m/s ² , 5Hz~150 Hz (EN 61373) Lifetime: 5.72 m/s ² , 5Hz~150 Hz (EN 61373)
Shock	50 m/s ² , 30 msec (EN 61373)
Certified	EN50155:2021, EN50153:2014 EN50121-3-2:2015, CE Class-A, FCC Class-A, EN45545

Ordering Information

MPT-3000RSM	MPT-3000R with MBT-3001R, Intel® Atom® Processor E3845 w/ 2x 2GB DDR3L-1333, SSD bay, No PSU, No storage (RoHS)
MPT-3000RHVSM	MPT-3000R with MBT-3001R, Intel® Atom® Processor E3845 w/ 2x 2GB DDR3L-1333, SSD bay, No PSU, No storage (RoHS) 72V/110V DC
M12-PWR-Cable-1	120cm M12 power cable for MPT series / Lead Only
M12-USB-Cable-1	300cm M12 to one USB receptacle cable for MPT series
M12-RJ45-Cable-1	300cm M12 to one RJ45 jack cable
Fuse-HV	Fuse for HV version

Dimensions

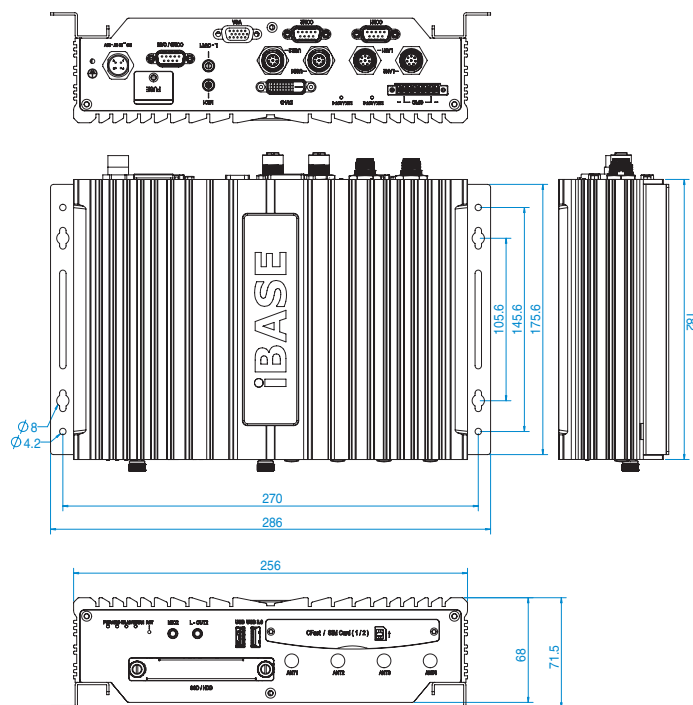



Features

- Fanless and ruggedized design
- Robust M12 connectors for dual GbE, USB and power input
- Dual SIM sockets support WWAN redundancy
- Onboard isolated CAN 2.0A / 2.0B / CAN-FD
- Removable 2.5" device bay for SSD storage
- Rich I/O interfaces for wireless, SSD, GPS, WWAN and add-on card expansion
- Ignition power control
- Wide-range voltage GPIO interface
- 1x USB Type-C with graphics output for quick setting and diagnostics

Specifications

System Mainboard	MBT-3101R
CPU Type	Intel® Atom® x6425RE Processor
Processor Speed	Up to 1.9GHz
Memory	2x 4GB DDR4-3200 SO-DIMM (Dual Channel)
Front Panel External I/O	2x USB3.2 Gen2 stack Type-A connector 1x DisplayPort with lockable hole design 2x External accessible SIM socket 2x Removable 2.5" SSD device bay 1x 3.5mm Line-out / MIC-in 1x Reset button 1x 8-pin terminal block for digital I/O with 24V input and output 6x SMA antenna holes 4x Light-pipe for status LED indicators
Rear Panel External I/O	2x M12 X-code 8P female for GbE LAN1/LAN2 1x M12 A-code 4P male for DC-input 1x DVI-D connector, 1 x VGA connector 1x USB Type-C connector with DP 1x 4-pin terminal block for 2 x CAN bus master 1x DB9M for COM#1 / COM#2 1x Removable blade fuse holder 2x Light-pipe for LAN status LED indicators
Storage	1x M.2 2280 M-Key socket for NVMe SSD (PCI-E x4 [Gen.4]) 1x 2.5" removable device bay for SSD
Expansion slots	1x M.2 2230 E-Key socket for WLAN & BT connection (PCI-E + USB2.0 + SMBus). 1x M.2 3042/52 B-Key socket for WWAN (4G/5G) connection (PCI-E + USB3.2 + SMBus). 1x M.2 2280 M-Key socket for NVMe SSD / Hailo AI module (PCI-E x4 [Gen.4]) 1x Mini PCI-E full-size socket for MVB/CAN FD module (PCI-E + USB2.0 + SMBus)
Power Supply	DC-input for 24V/72V/110V
Construction	Aluminum
Chassis Color	Black
Mounting	Wall mount
Dimensions	256.0 (W) x 182.0 (D) x 83.0 (H) mm 10.08" (W) x 7.17" (D) x 3.27" (H)
Operating Temperature	-40°C ~70°C (-40°F~158°F) (w/o FAN & SSD), up to 85°C for 10 minutes according to EN 50155 OT4 -20°C ~55°C (-4°F~131°F) (w/ PCI-E card)
Storage Temperature	-40°C ~ 85°C (-40°F~185°F)
Relative Humidity	10 ~ 95% RH @45°C (non-condensing)

Vibration	Function: 1 m/s ² , 5Hz~150 Hz (EN 61373) Lifetime: 7.9 m/s ² , 5Hz~150 Hz (EN 61373)
Shock	50 m/s ² , 30 msec (EN 61373)
Certified	EN 50155:2021, EN 45545 -2 HL1/2/3 2020 CE (EN 62368-1 / EN55032 / EN55035), FCC Class A UKCA (BS EN 62368-1 / BS EN55032 / BS EN55035)

Ordering Information

MPT-3100R	MPT-3100R with MBT-3101R, Intel® Atom® x6425RE Processor w/ 2x 4GB DDR4-3200, 1x SSD bay, No PSU, No storage (RoHS) 24V DC-in
MPT-3100RH	MPT-3100R with MBT-3101R, Intel® Atom® x6425RE Processor w/ 2x 4GB DDR4-3200, 1x SSD bay, No PSU, No storage (RoHS) 72/110V DC-in



Specifications

System Mainboard	MBT-7001R
CPU Type	7th/6th Gen Intel® Core Processor
Processor Speed	2.6GHz
Memory	2x 4GB DDR4-2133 SO-DIMM (Dual Channel)
Front Panel External I/O	CFlash, 2.5" device bay, 2nd Mic-In & Line-Out 2x SIM sockets, 2x USB 3.0, Reset button Status LEDs, 4x antenna connectors
Rear Panel External I/O	DVI-D, VGA, 3x COMs (2x COMs for HV model, one with RS422/485 options), 2x M12 GbE, 2x M12 USB 2.0, M12 power connection, 1st Mic-In & Line-Out, GPIO, GbE status LEDs, 1x PCI-E (x4) slot
Storage	2x 2.5" device bay for SSD & HDD
Expansion slots	1x Half-size Mini PCI-E socket (USB 2.0) 1x Full-size Mini PCI-E socket (USB 2.0 + PCI-E) 1x 2230 M.2 E-Key socket (USB 2.0 + PCI-E) 1x 3042 M.2 B-Key WWAN socket (USB 2.0) 1x 2280 M.2 M-Key SSD socket (SATA)
Power Supply	DC 9V~36V / 72V / 110V
Construction	Aluminum
Chassis Color	Black
Mounting	Custom mounting rail
Dimensions	256.0 (W) x 182.0 (D) x 83.0 (H) mm 10.08" (W) x 7.17" (D) x 3.27" (H)
Operating Temperature	SSD: -30°C ~ 55°C (-22°F~131°F) HDD: -20°C ~ 45°C (-4°F~113°F) SSD: -40°C ~ 70°C (-40F ~ 158F) system only
Storage Temperature	-35°C ~ 85°C (-31°F~185°F)
Relative Humidity	10 ~ 95% RH @45°C (non-condensing)
Vibration	Function: 1 m/s ² , 5Hz~150 Hz (EN 61373) Lifetime: 5.72 m/s ² , 5Hz~150 Hz (EN 61373)
Shock	50 m/s ² , 30 msec (EN 61373)
Certified	EN50155:2021, EN50153:2014 EN50121-3-2:2015, CE Class-A, FCC Class-A, EN45545

Features

- EN50155 (2021) certified
- Fanless and ruggedized design
- Robust M12 connectors for dual GbE, USB and power input
- Dual SIM sockets support WWAN redundancy
- Two removable 2.5" device bay and CFlash socket
- Rich I/O interfaces for wireless, SSD, GPS, WWAN and add-on card expansion
- Ignition power control
- Wide-range voltage GPIO interface
- One PCI-E (x4) expansion

Ordering Information

MPT-7000RSM	MPT-7000R with MBT-7001R, 6th Gen Intel® Core™ i7-6600U Processor w/ 2x 4GB DDR4-2133, 2x SSD bay, No PSU, No storage (RoHS) 24V DC
MPT-7000RHVSM	MPT-7000R with MBT-7001R, 6th Gen Intel® Core™ i7-6600U Processor w/ 2x 4GB DDR4-2133, 2x SSD bay, No PSU, No storage (RoHS) 72V/110V DC
M12-PWR-Cable-1	120cm M12 power cable For MPT Series / Lead Only
M12-USB-Cable-1	300cm M12 to one USB receptacle cable for MPT series
M12-RJ45-Cable-1	300cm M12 to one RJ45 jack cable
Fuse-HV	Fuse for HV version

Dimensions

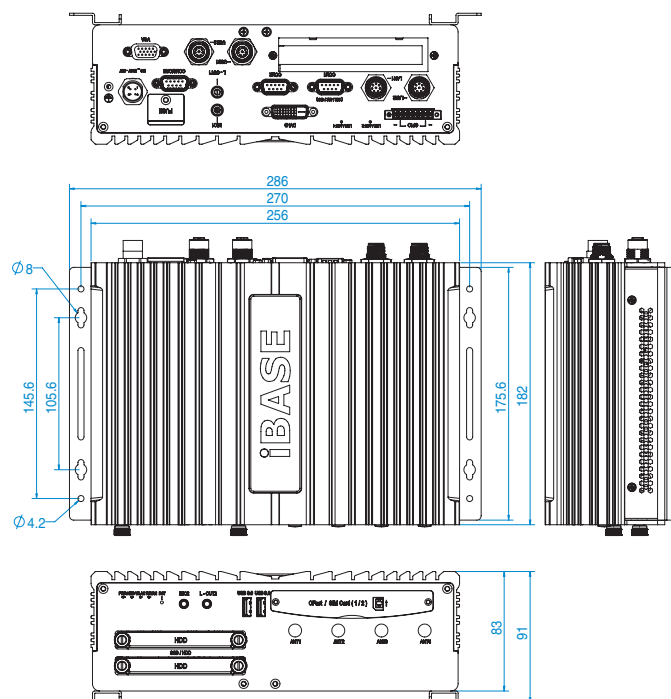

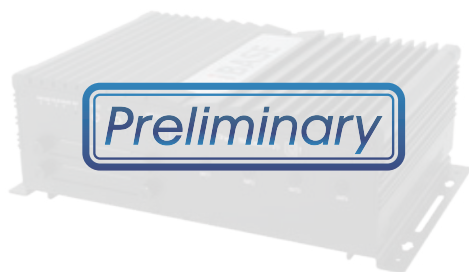

Features

- Fanless and ruggedized design
- Robust M12 connectors for dual GbE, USB and power input
- Dual SIM sockets support WWAN redundancy
- Onboard isolated CAN 2.0A / 2.0B / CAN-FD
- Two removable 2.5" device bay for SSD storage
- Rich I/O interfaces for wireless, SSD, GPS, WWAN and add-on card expansion
- Ignition power control
- Wide-range voltage GPIO interface
- 1x USB Type-C with graphics output for quick setting and diagnostics

Specifications

System Mainboard	MBT-7100R
CPU Type	13th Gen Intel® Core U-Series Processor
Processor Speed	Up to 3.0GHz
Memory	2x 8GB DDR5-4800 SO-DIMM (Dual Channel)
Front Panel External I/O	2x USB3.2 Gen2 stack Type-A connector 2x External accessible SIM socket 1x USB Type-C connector with DP 2x Removable 2.5" SSD device bay 1x 3.5mm green color audio for Line-out 1x 3.5mm pink color audio for MIC-in 1x Reset button 1x 10-pin terminal block for digital I/O 8x SMA antenna holes 6x Light-pipe for status LED indicators (2x programmable)
Rear Panel External I/O	2x M12 X-code 8P female for GbE LAN1/LAN2 1x M12 A-code 4P male for DC-input 2x M12 D-code 4P female for USB 2.0 1x DisplayPort with lockable hole design 1x DVI-D connector, 1x VGA connector 1x 6-pin terminal block for 2 x CAN bus master 2x DB9M for COM#1 / COM#2 1x Removable blade fuse holder 4x Light-pipe for LAN status LED indicators 1x M3 with washer screw hole for grounding connection
Storage	1x M.2 2280 M-Key socket for NVMe SSD (PCI-E x4 [Gen.4]) 2x 2.5" removable device bay for SSD
Expansion slots	1x M.2 2230 E-Key socket for WLAN & BT connection (PCI-E + USB2.0 + SMBus). 1x M.2 3042/52 B-Key socket for WWAN (4G/5G) connection (PCI-E + USB3.2 + SMBus). 1x M.2 2280 M-Key socket for NVMe SSD / Hailo AI module (PCI-E x4 [Gen.4]) 1x Mini PCI-E full-size socket for MVB/CAN FD module 1x Mini PCI-E half-size socket (USB 2.0) (PCI-E + USB2.0 + SMBus)
Power Supply	DC-input for 24V/72V/110V
Construction	Aluminum
Chassis Color	Black
Mounting	Wall mount
Dimensions	256.0 (W) x 182.0 (D) x 83.0 (H) mm 10.08" (W) x 7.17" (D) x 3.27" (H)
Operating Temperature	-40°C ~ 70°C (-40°F ~ 158°F) (w/o FAN & SSD), up to 85°C for 10 minutes according to EN 50155 OT4 -20°C ~ 55°C (-4°F ~ 131°F) (w/ PCI-E card)

Storage Temperature	-40°C ~ 85°C (-40°F ~ 185°F)
Relative Humidity	10 ~ 95% RH @45°C (non-condensing)
Vibration	Function: 1 m/s ² , 5Hz~150 Hz (EN 61373) Lifetime: 7.9 m/s ² , 5Hz~150 Hz (EN 61373)
Shock	50 m/s ² , 30 msec (EN 61373)
Certified	EN 50155:2021, EN 45545 -2 HL1/2/3 2020 CE (EN 62368-1 / EN55032 / EN55035), FCC Class A UKCA (BS EN 62368-1 / BS EN55032 / BS EN55035)

Ordering Information

MPT-7100R	MPT-7100R with MBT-7101R, 13th Gen Intel® Core™ i7-1365URE Processor w/ 2x 8GB DDR5-4800, 2x SSD bay, No PSU, No storage (RoHS) 24V DC-in
MPT-7100RH	MPT-7100R with MBT-7101R, 13th Gen Intel® Core™ i7-1365URE Processor w/ 2x 8GB DDR5-4800, 2x SSD bay, No PSU, No storage (RoHS) 72/110V DC-in

MPT-8000R

Railway Computer System

EN50155/EN45545 Certified 10th Gen Intel® Core™ Processor
Railway Computer System with M12 Connection and Dual WWAN



Features

- EN50155 (2021) / EN45545-2 certified
- AI solution for Transportation application
- Supports 10th Gen Intel® Core™ Desktop processors
- Up to 10x GbE ports (8x with PoE capability)
- Optional 10G LAN
- Supports Intel® Movidus Vision Acceleration M.2 modules
- Supports Wi-Fi 6 CNVi, dual WWAN channels, RAID 0/1/5
- 1x USB Type-C with graphics output for quick setting and diagnostics

Specifications

System Mainboard	MBT-8001RW
CPU Type	10th Gen Intel® Core™ Desktop processors
Processor Speed	4.5GHz
Memory	2x DDR4-2666 SO-DIMM, 2x 8GB (default) Maximum size supported: 128GB
Front Panel External I/O	2x Accessible 2.5" device bay (SSD/HDD) 2x M12 X-code 8-pin for GbE LAN, isolated 1x M12 4-pin A-code for USB 2.0, isolated 1x M12 4-pin A-code for USB 1.1, isolated 1x 3.5mm pink audio connector for MIC-Input 1x 3.5mm blue audio connector for Line in 4x SMA Antenna holes with cap 2x PCI-Ex4 card slots for IDT8102/IDT 7204 (with cover when empty) - IDT8102: 2x 10G LAN card - IDT7204: 4x 1G PoE card 2x External accessible SIM socket 1x Micro SD card socket 1x Recessed Access Tach-switch for System Reset 1x USB type-C with graphics (No PD function) 1x USB3.2 Gen.2 type-A Indicators: Four light-pipe for four status LED - 1x 0402 SMT green LED for power status - 1x 0402 SMT white LED for storage activity status - 1x 0402 SMT blue LED for WLAN activity status - 1x 0402 SMT amber LED for WWAN activity - 2x 0402 SMT green LED, programmable
Rear Panel External I/O	1x Main power input, Staubli connector 2x Removable with screw lock FUSE holder 1x Backup power source, 24VDC only 1x DVI-D output 1x HDMI output 1x USB3.2 Gen.1 type-A 1x 3.5mm green audio connector for Line-out 1x Male DSUB9 for RS-485, isolated 1x Male DSUB9 connector for RS-232/485, isolated 1x Female DSUB9 for 8x DO and ground by cable, isolated 1x Female DSUB9 for 8x DI and ground by cable, isolated 1x M4 with washer screw hole for grounding connection 4x SMA Antenna holes with cap
Storage	2x 2.5" Removable device bay for SSD devices 2x M.2 M-key SSD devices RAID 0/1/5 supported, Max. 4x SATA devices
Expansion slots	1x mPCI-E full/half-size socket 1x 3042/52 M.2 B-Key socket for WWAN (supports SIM1) - This M.2 socket comes with USB2.0/3.0/PCI-Ex1 interface only 1x 3042/52 M.2 B-Key socket for WWAN (supports SIM2) - This M.2 socket comes with USB2.0/PCI-Ex1 interface 1x 2242/80 M.2 M-key socket for SSD/VPD/WLAN card 1x 2242/80 M.2 M-key socket for SSD/VPD/WLAN card (NVMe support) 1x 2230 M.2 E-Key socket for WLAN (CNVi support)

Power Supply	Main: 72V/110VDC Second: 24V DC only, once the main power loses, switch to second power automatically
Construction	Metal
Chassis Color	Black
Mounting	19" Rack mount
Dimensions	482 (W) x 308 (D) x 132 (H) mm 18.97" (W) x 12.13" (D) x 5.2" (H)
Operating Temperature	-10°C ~ 60°C (14°F ~ 140°F)
Storage Temperature	-40°C ~ 85°C (-40°F ~ 185°F)
Relative Humidity	10 ~ 95% @ 45°C, (non-condensing)
Vibration	EN61373
Shock	EN61373
Certified	EN50155: 2021, EN45545-2 CE/FCC class-A

Ordering Information

MPT-8000RH	MPT-8000R with MBT-8001R, 10th Gen Intel® Core Xeon W-1250TE with W480E PCH, w/ 2x 8GB DDR4-2666, 2x SSD bay, No PSU, No storage (RoHS2) 72/110V DC-input
------------	---

Dimensions

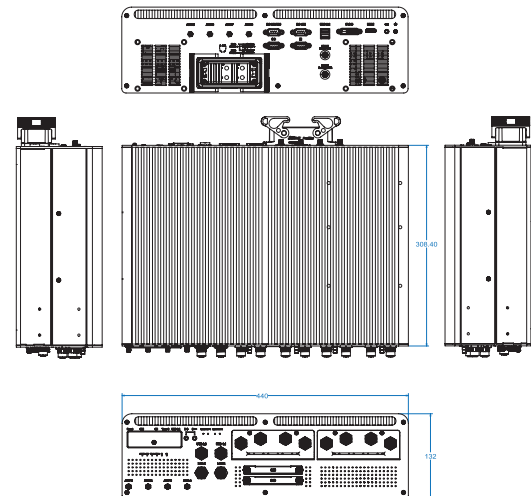



MPT-1000V VIDEO



Features

- SIM socket supports Dual WWAN
- Removable 2.5" device bay
- Ignition power-on signal control
- Onboard CANbus
- Rich I/O interfaces for wireless, SSD, GPS, WWAN and add-on card expansion
- Add on card slots reset function
- Quick accessible RTC battery

Specifications

System Mainboard	MBT-1002V
CPU Type	Intel® Atom® x7-E3950 Processor Intel® Celeron® N3350 Processor
Processor Speed	1.6GHz , up to 2.0GHz
Memory	Onboard 4GB LPDDR4 memory (Intel® N3350 SKU) Onboard 8GB LPDDR4 memory (Intel® E3950 SKU)
Front panel I/O	<p>1x DVI-D connector for display connection 1x VGA DSUB15 2x RJ45 for GbE LAN 1x 3.5mm blue color audio connector for line input 1x 3.5mm pink color audio connector for MIC-Input 2x external accessible SIM socket (Coved) 1x external micro SD card slot (Coved together with SIM card holder) 1x Stack USB connector for 2x USB3.1 (#1/#2) 1x DUSB 9 for COM1 RS-232/485 1x DUB9 for COM2 RS-485 isolated 1x DSUB15 for DIDO 6in/6out isolated</p> <p>6x insulated DO:</p> <ul style="list-style-type: none"> - Output type: Darlingtion transistor - Sink current •500 mA for one channel @100% duty - Source current •500 mA for one channel @100% duty cycle - Supply voltage: 5V-35V DC - Isolation voltage: 2500V RMS <p>6x insulated DI:</p> <ul style="list-style-type: none"> - Maximum input range •24V, non-polarity - Digital logic levels •0~24 V, non-polarity - Input high voltage: 5V~24V - Input low voltage: 0~1.5V - Input resistance: 1.2 k @ 0.5W - Isolation voltage •2500V RMS <p>1x tack switch for system reset 1x tack switch for Add-on cards reset 1x tack switch for power firmware load default</p> <p>Indicators:</p> <ul style="list-style-type: none"> - 1x Green color LED for power status - 1x White color LED for storage activity status - 1x Blue color LED for WLAN activity status (option) - 1x Orange color LED for WWAN activity status (option) - 1x Green color LED, programmable - 1x Red color LED for warning of wrong power voltage connected - 1x Blue color LED for external battery connected
Rear Panel External I/O	<p>2x DSUB9 for COM3/4 RS232 1x 4 pins terminal block for 2 masters CANbus 1x USB3.0 flag type-A 1x Audio jack for line out 1x Tack switch for clear CMOS 1x Open window for accessing RTC battery 1x 6-pins ATX connector for external battery, and 19V DC(Max:1A) output 1x Blade fuse socket with cover 1x DIP switch for selecting power mode: CAR/DC 1x 3-pin thermanil block connector for power input and IGN</p>
Storage	1x 2.5" device bay for SSD/HDD 1x mSATA via miniPCI-E slot

Expansion slots	1x miniPCI-E full/Half-size, supports mSATA 1x miniPCI-E full/Half-size, supports second SIM card 1x M.2 B-key 30x42 with USB 2.0 and USB 3.0 signal only, supports first SIM card
Power Supply	9V~32V DC input(10%) without backup battery power 12V~32V DC input with backup battery Ignition detection: enable (Car mode)/ disable (DC mode) Reverse protection
Construction	Matel
Chassis Color	Black
Mounting	Side mounting, rack mounting with optional bracket
Dimensions	300 (W) x 158.4 (D) x 66 (H) mm 11.8" (W) x 6.23" (D) x 2.6" (H)
Operating Temperature	-40°C~70°C, with SSD, not including add-on cards (Intel® E3950 SKU) -5°C~50°C, with SSD, not including add-on cards (Intel® N3350 SKU)
Storage Temperature	-40°C~85°C (-40°F~185°F)
Relative Humidity	10 ~ 95% @ 45°C, (non-condensing)
Vibration	Operating/Non-operating: 2,26 Grms (5~500 Hz) / MIL-STD-810G composite wheeled condition (Z-axis only)
Shock	Non-operating: Sawtooth: 40G, 11 msec (Z-axis) Operating: Sawtooth: 20G, 11 msec (Z-axis)
Certified	E-Mark, CE (EN 62368 / EN55032 / EN55025)/ FCC Class-A

Ordering Information

MPT-1000V8GM	Intel® E3950 processor, 8G LPDDR4 RAM onboard, 9V~32V DC input (12V~32VDC if connected with backup power), ignition detection, no OS, adaptor and storage
MPT-1000VNM	Intel® N3350 processor, 4G LPDDR4 RAM onboard, 9V~32V DC input (12V~32VDC if connected with backup power), ignition detection, no OS, adaptor and storage

Dimensions

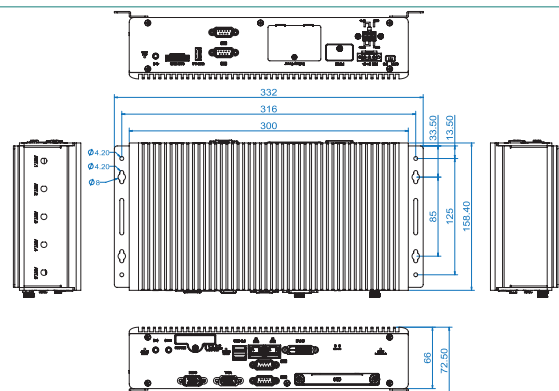



Features

- Fanless and ruggedized design
- Dual SIM sockets support WWAN redundancy
- Removable 2.5" device bay and CFAST socket
- Rich I/O interfaces for wireless, SSD, GPS, WWAN and add-on card expansion
- Fully car battery power control
- Wide-range voltage GPIO interface
- Optional CAN 2.0B/ OBD-II function (SAE J1939)

Specifications

System Mainboard	MBT-3001V
CPU Type	Intel® Atom® Processor E3845
Processor Speed	1.91GHz
Memory	2x 2GB DDR3L-1333 SO-DIMM (Dual Channel)
Front Panel External I/O	CFAST, 2.5" device bay, 2nd Mic-In & Line-Out 2x SIM sockets, 1x USB 3.0, 1x USB 2.0, Reset button, Status LEDs, 4x antenna connectors
Rear Panel External I/O	DVI-D, VGA, 3x COMs (one with RS422/485 options) 2x GbE, 2x USB 2.0, power connection 1st Mic-In & Line-Out, GPIO, GbE status LEDs
Storage	2.5" device bay for SSD & HDD
Expansion slots	1x Half-size Mini PCI-E socket (USB 2.0) 1x Full-size Mini PCI-E socket (USB 2.0 + PCI-E) 1x 2230 M.2 E-Key socket (USB 2.0 + PCI-E) 1x 3042 M.2 B-Key WWAN socket (USB 2.0) 1x 2280 M.2 M-Key SSD socket (SATA)
Power Supply	DC 9V~36V
Construction	Aluminum
Chassis Color	Black
Mounting	Custom mounting rail
Dimensions	256.0 (W) x 182.0 (D) x 55.0 (H) mm 10.08" (W) x 7.17" (D) x 2.16" (H)
Operating Temperature	SSD: -40°C ~ 70°C (-40°F~158°F) HDD: -20°C ~ 50°C (-4°F~122°F)
Storage Temperature	-40°C ~ 85°C (-40°F~185°F)
Relative Humidity	-40°C ~ 85°C (-40°F~185°F)
Vibration	Operating/Non-operating (SSD): 2.26 Grms (5~500 Hz) / MIL-STD-810G composite wheeled condition (Z-axis only) Operating/Non-operating (HDD): 1.04 Grms (5~500 Hz) / MIL-STD-810G highway truck condition (Z-axis only)
Shock	Non-operating: Sawtooth: 40G, 11 msec (Z-axis) Operating: Sawtooth: 20G, 11msec (Z-axis)
Certified	E-mark, CE class B, FCC class B

Ordering Information

MPT-3000VSM	MPT-3000V with MBT-3001V, Intel® Atom® Processor E3845 w/ 2x 2GB DDR3L-1333, SSD bay, No PSU, No storage (RoHS)
LTE-ANT-INT-1	20cm 4G/3G WWAN antenna cable from M.2 to SMA Jack
LTE-ANT-INT-2	20cm 4G/3G WWAN antenna cable from mPCI-E to SMA Jack
WLAN-ANT-INT-1	20cm WLAN antenna cable from M.2 to SMA Jack

Dimensions

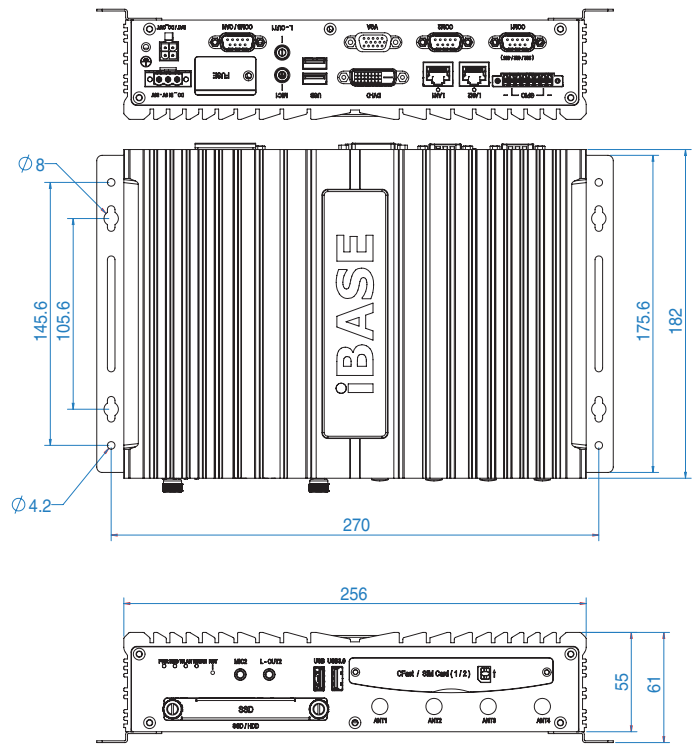



Features

- Fanless and ruggedized design
- Robust M12 connectors for dual GbE
- Dual SIM sockets support WWAN redundancy
- Onboard isolated CAN 2.0A / 2.0B / CAN-FD
- Removable 2.5" device bay for SSD storage
- Rich I/O interfaces for wireless, SSD, GPS, WWAN and add-on card expansion
- Ignition power control
- Wide-range voltage GPIO interface
- 1x USB Type-C with graphics output for quick setting and diagnostics

Specifications

System Mainboard	MBT-3101V
CPU Type	Intel® Atom® x6425RE Processor
Processor Speed	Up to 1.9GHz
Memory	2x 4GB DDR4-3200 SO-DIMM (Dual Channel)
Front Panel External I/O	2x USB 3.2 Gen2 stack Type-A connector 1x DisplayPort with lockable hole design 2x External accessible SIM socket 2x Removable 2.5" SSD device bay 1x 3.5mm Line-out / MIC-in 1x Reset button 1x 8-pin terminal block digital I/O with 24V input and output 6x SMA antenna holes 4x Light-pipe for status LED indicators
Rear Panel External I/O	2x M12 X-code 8P female for GbE LAN1/LAN2 1x M12 A-code 4P male for DC-input 1x DVI-D connector, 1 x VGA connector 1x USB Type-C connector with DP 1x Terminal block DIP 4 pins for 2 x CAN bus master 1x DB9M for COM#1 / COM#2 1x Removable blade fuse holder 2x Light-pipe for LAN status LED indicators
Storage	1x M.2 2280 M-Key socket for NVMe SSD (PCI-E x4 [Gen.4]) 1x 2.5" removable device bay for SSD
Expansion slots	1x M.2 2230 E-Key socket for WLAN & BT connection (PCI-E + USB2.0 + SMBus). 1x M.2 3042/52 B-Key socket for WWAN (4G/5G) connection (PCI-E + USB3.2 + SMBus). 1x M.2 2280 M-Key socket for NVMe SSD / Hailo AI module (PCI-E x4 [Gen.4]) 1x Mini PCI-E full-size socket for MVB/CAN FD module (PCI-E + USB2.0 + SMBus)
Power Supply	DC-input 9V ~ 36V
Construction	Aluminum
Chassis Color	Black
Mounting	Wall mount
Dimensions	256.0 (W) x 182.0 (D) x 83.0 (H) mm 10.08" (W) x 7.17" (D) x 3.27" (H)
Operating Temperature	-40°C ~ 70°C (-40°F ~ 158°F) (w/o FAN & SSD) -20°C ~ 55°C (-4°F ~ 131°F) (w/ PCI-E card)
Storage Temperature	-40°C ~ 85°C (-40°F ~ 185°F)
Relative Humidity	10 ~ 95% RH @45°C (non-condensing)

Vibration	Operating/Non-operating (SSD): 2,26 Grms (5~500 Hz) / MIL-STD-810G composite wheeled condition (Z-axis only)
Shock	Operating: Sawtooth: 20G, 11 msec (Z-axis) / MIL-STD-810G Non-operating: Sawtooth: 40G, 11 msec (Z-axis) / MIL-STD-810G
Certified	E-Mark-24 CE (EN 62368-1 / EN55032 / EN55035), FCC Class B UKCA (BS EN 62368-1 / BS EN55032 / BS EN55035)

Ordering Information

MPT-3100V	MPT-3100V with MBT-3101V, Intel® Atom® x6425RE Processor w/ 2x 4GB DDR4-3200, 1x SSD bay, No PSU, No storage (RoHS)
-----------	---

MPT-7000V

In-Vehicle Computer System

E-mark Certified 7th/6th Gen Intel® Core™ Processor In-Vehicle Computer System with WWAN Redundancy



Features

- Fanless and ruggedized design
- Dual SIM sockets support WWAN redundancy
- Two removable 2.5" device bay and CFast socket
- Rich I/O interfaces for wireless, SSD, GPS, WWAN and add-on card expansion
- Full car battery power control
- Wide-range voltage GPIO interface
- One PCI-E (x4) expansion

Specifications

System Mainboard	MPT-7001V
CPU Type	7th/6th Gen Intel® Core Processor
Processor Speed	2.6GHz
Memory	2x 4GB DDR4-2133 SO-DIMM (Dual Channel)
Front Panel External I/O	CFast, 2.5" device bay, 2nd Mic-In & Line-Out 2x SIM sockets, 2x USB 3.0, Reset button Status LEDs, 4x antenna connectors
Rear Panel External I/O	DVI-D, VGA, 3x COMs (one with RS422/485 options) 2x GbE, 2x USB 2.0, power connection, 1st Mic-In & Line-Out, GPIO, GbE status LEDs, 1x PCI-E (x4) slot
Storage	2x 2.5" device bay for SSD & HDD
Expansion slots	1x Half-size Mini PCI-E socket (USB 2.0) 1x Full-size Mini PCI-E socket (USB 2.0 + PCI-E) 1x 2230 M.2 E-Key socket (USB 2.0 + PCI-E) 1x 3042 M.2 B-Key WWAN socket (USB 2.0) 1x 2280 M.2 M-Key SSD socket (SATA)
Power Supply	DC 9V~36V
Construction	Aluminum
Chassis Color	Black
Mounting	Custom mounting rail
Dimensions	256.0 (W) x 182.0 (D) x 83.0 (H) mm 10.08" (W) x 7.17" (D) x 3.27" (H)
Operating Temperature	SSD: -30°C ~ 55°C (-22°F~131°F) HDD: -20°C ~ 45°C (-4°F~113°F) SSD: -40°C ~ 70°C (-40F ~ 158°F) system only
Storage Temperature	-35°C ~ 85°C (-31°F~185°F)
Relative Humidity	10 ~ 95% RH @ 45°C (non-condensing)
Vibration	Operating/Non-operating (SSD): 2,26 Grms (5~500 Hz) / MIL-STD-810G composite wheeled condition (Z-axis only) Operating/Non-operating (HDD): 1,04 Grms (5~500 Hz) / MIL-STD-810G highway truck condition (Z-axis only)
Shock	Non-operating: Sawtooth: 40G, 11 msec (Z-axis) Operating: Sawtooth: 20G, 11msec (Z-axis)
Certified	E-mark, CE class B, FCC class B

Ordering Information

MPT-7000VSM	MPT-7000V with MBT-7001V, 6th Gen Intel® Core™ i7-6600U Processor w/ 2x 4GB DDR4-2133, 2xSSD bay, No PSU, No storage (RoHS)
LTE-ANT-INT-1	20cm 4G/3G WWAN antenna cable from M.2 to SMA Jack
LTE-ANT-INT-2	20cm 4G/3G WWAN antenna cable from mPCI-E to SMA Jack
WLAN-ANT-INT-1	20cm WLAN antenna cable from M.2 to SMA Jack

Dimensions

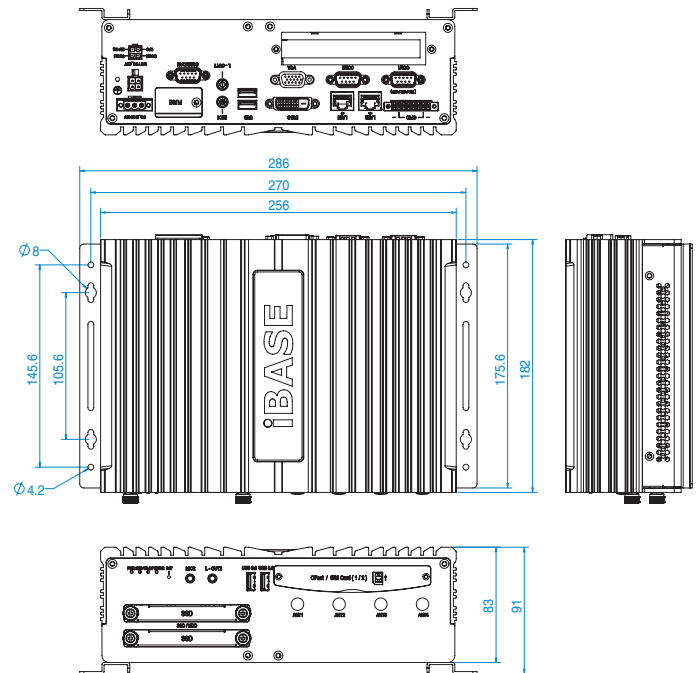

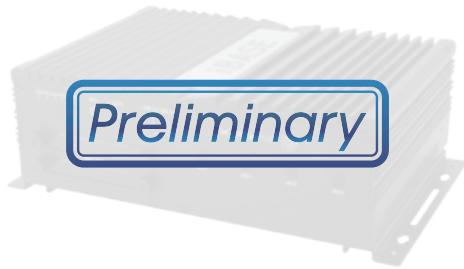

Features

- Fanless and ruggedized design
- Robust M12 connectors for dual GbE
- Dual SIM sockets support WWAN redundancy
- Onboard isolated CAN 2.0A / 2.0B / CAN-FD
- Full car battery ignition power control
- Two removable 2.5" device bay for SSD storage
- Rich I/O interfaces for wireless, SSD, GPS, WWAN and add-on card expansion
- Wide-range voltage GPIO interface
- 1x USB Type-C with graphics output for quick setting and diagnostics

Specifications

System Mainboard	MBT-7100V
CPU Type	13th Gen Intel® Core U-Series Processor
Processor Speed	Up to 3.0GHz
Memory	2x 8GB DDR5-4800 SO-DIMM (Dual Channel)
Front Panel External I/O	2x USB3.2 Gen2 stack Type-A connector 2x External accessible SIM socket 1x USB Type-C connector with DP 2x Removable 2.5" SSD device bay 1x 3.5mm green color audio for Line-out 1x 3.5mm pink color audio for MIC-in 1x Reset button 1x 10-pin terminal block for digital I/O 8x SMA antenna holes 6x Light-pipe for status LED indicators (2x programmable)
Rear Panel External I/O	2x M12 X-code 8P female for GbE LAN1/LAN2 2x M12 D-code 4P female for USB 2.0 1x 3-pin terminal block for DC-input 1x DisplayPort with lockable hole design 1x DVI-D connector, 1 x VGA connector 1x 6-pin terminal block for 2 x CAN bus master 2x DB9M for COM#1 / COM#2 1x Removable blade fuse holder 4x Light-pipe for LAN status LED indicators 1x M3 with washer screw hole for grounding connection
Storage	1 x M.2 2280 M-Key socket for NVMe SSD (PCI-E x4 [Gen.4]) 2 x 2.5" removable device bay for SSD
Expansion slots	1x M.2 2230 E-Key socket for WLAN & BT connection (PCI-E + USB2.0 + SMBus). 1x M.2 3042/52 B-Key socket for WWAN (4G/5G) connection (PCI-E + USB3.2 + SMBus). 1x M.2 2280 M-Key socket for NVMe SSD / Hailo AI module (PCI-E x4 [Gen.4]) 1x Mini PCI-E full-size socket for MVB/CAN FD module 1x Mini PCI-E half-size socket (USB 2.0)(PCI-E + USB2.0 + SMBus)
Power Supply	DC-input 9V ~ 36V
Construction	Aluminum
Chassis Color	Black
Mounting	Wall mount
Dimensions	256.0 (W) x 182.0 (D) x 83.0 (H) mm 10.08" (W) x 7.17" (D) x 3.27" (H)
Operating Temperature	-40°C ~ 70°C (-40°F~158°F) (w/o FAN & SSD) -20°C ~ 55°C (-4°F~131°F) (w/ PCI-E card)

Storage Temperature	-40°C ~ 85°C (-40°F~185°F)
Relative Humidity	10 ~ 95% RH @45°C (non-condensing)
Vibration	Operating/Non-operating (SSD): 2.26 Grms (5~500 Hz) / MIL-STD-810G, composite wheeled condition (Z-axis only)
Shock	Operating: Sawtooth: 20G, 11msec (Z-axis) / MIL-STD-810G, Non-operating: Sawtooth: 40G, 11 msec (Z-axis) / MIL-STD-810G
Certified	E-Mark-24 CE (EN 62368-1 / EN55032 / EN55035), FCC Class B UKCA (BS EN 62368-1 / BS EN55032 / BS EN55035)

Ordering Information

MPT-7100V	MPT-7100V with MBT-7101V, 13th Gen Intel® Core™ i7-1365URE Processor w/ 2x 8GB DDR5-4800, 2x SSD bay, No PSU, No storage (RoHS)
-----------	---



Specifications

CPU Type	MRD286-N42: Intel® Pentium® Processor N4200 (1.1GHz~2.5GHz) MRD286-I50: Intel® Atom™ x7-E3950 Processor (1.6GHz~2.0GHz)
Memory	2x DDR3L SO-DIMM, Max. 8GB, 1x Default 4GB
Display Size	28.6"
Max. Resolution	1920 x 540
Luminance (cd/m ²)	1,000
Contrast	1000:1
Max. Color	16.7M
View Angle (H°/V°)	178/178
Backlight Lifetime(hrs)	50,000
Touch Type	None, enhanced glass, anti-scattering, IK07 rating
Touch Interface	None
Light Transmission (%)	90
Point of touch	None
I/O Interface	1x 8-pin M12 A-code for 2x USB 2.0 1x 8-pin M12 A-code for RS-232/422/485 1x 8-pin M12 X-code GbE LAN 1x 3-pin M12 A-code Power Connector
Power Button	IP65 membrane key
Power Input Range	24V DC or 110V DC
Membrane Control	Dimming control, power on/off
Audio	2x IP65 2W speaker
Internal Expansion	None
Wireless	Optional
Storage	1x 2.5" HDD space, default 64GB SSD, easy accessible
IP Rating	IP65 for other sides IP43
Thermal Design	Fanless
Construction	Metal
Chassis Color (Front/Back)	Black/Black
Mounting	Side mount, VESA 100x100
Dimensions	780 (W) x 278 (D) x 77 (H) mm 30.7"(W) x 10.9"(D) x 3.03"(H)
Net Weight	15 kgs
Operating Temperature	-25°C ~ 55°C (-13°F ~ 131°F)
Storage Temperature	-25°C~70°C (-13°F ~ 158°F)
Storage Humidity	0~90% @40°C
Certified	CE/FCC Class-A +LVD EN50155, EN45545-2 Compliance
Operating Systems	Windows 10, Linux Kernel 4.X

Features

- Intel® Atom® x7-E3950 / Pentium® N4200 Processor
- Sunlight readable 1000nits bar type panel
- Auto-dimming function
- IP65 front-panel waterproof protection
- Anti-scattering front side glass



Ordering Information

MRD286-N42	28.6" 1920 x 540 Bar Type-AIO, Intel® Pentium® Processor N4200, 4GB memory,64GB SSD, 24VDC power input, without adaptor
MRD286-N42H	28.6" 1920 x 540 Bar Type-AIO, Intel® Pentium® Processor N4200, 4GB memory,64GB SSD, 110VDC power input, without adaptor
MRD286-I50	28.6" 1920 x 540 Bar Type-AIO, Intel® Atom® x7-E3950 Processor, 4GB memory,64GB SSD, 24VDC power input, without adaptor
MRD286-I50H	28.6" 1920 x 540 Bar Type-AIO, Intel® Atom® x7-E3950 Processor, 4GB memory,64GB SSD, 110VDC power input, without adaptor

Dimensions

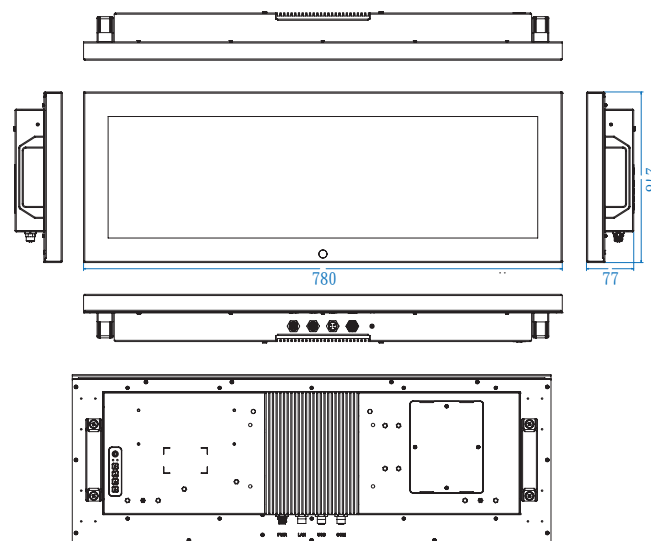



Features

- Intel® Atom® x7-E3950 Processor
- EN50155 (2017) & EN45545-2 certified
- Fully IP65 waterproof protection
- Supports ultra-long-life LCD panel, M12 connectors
- Flat bezel design, projected capacitive 15" touch screen
- Optional wireless communication
- Supports 24V DC or 72/110V DC power input



Specifications

CPU Type	Intel® Atom® x7-E3950 Processor 1.6GHz, up to 2.0GHz
Memory	Max DDR3L 8GB, Default 4GB
Display Size	15"
Max. Resolution	1024x768
Luminance (cd/m ²)	500
Contrast	1800:1
Max. Color	16.7M
View Angle (H°/V°)	178/178
Backlight Lifetime(hrs)	70,000
Touch Type	Projected capacitive
Touch Interface	USB
Light Transmission (%)	89
Point of touch	10
I/O Interface	2x M12 A-code 8P GbE 3x M12 D-code 4P USB 2.0 1x M12 A-code 8P for RS-232/422/485 1x M12 A-code 4P DC-input
Power Button	Membrane key
Power Input Range	DC24V or DC 72V/110V
Membrane Control	Brightness up/down, volume up/down, power on/off
Audio	2x speakers
Internal Expansion	1x miniPCI-E (Full size) 1x miniPCI-E (Half size)
Wireless	Optional, Via miniPCI-E device
Storage	1x 2.5" HDD space, default 128G SSD
Thermal Design	Fanless
Construction	Aluminums
Chassis Color (Front/Back)	Black/Black
IP Rating	IP65
Mounting	VESA 100x100/Rack mount
Dimensions	382.1mm (W) x 304.8mm (D) x 54.4mm (H) 15.04"(W) x 12"(D) x 2.14"(H)
Net Weight	6.36 kg
Operating Temperature	-30°C ~70°C (-22°F ~ 158°F) with SSD, not including add-on cards
Storage Temperature	-40°C ~ 85°C (-40°F ~ 185°F)
Storage Humidity	10%~90% @40°C (non-condensing)
Certified	EN50155:2017, EN45545-2 CE/FCC class-A

Operating Systems	Windows 10 64bit/ Linux Kernel 4.X
-------------------	------------------------------------

Ordering Information

MPPC1501PC	15" EN50155 Certified Panel PC, Intel® Atom® x7-E3950 Processor, 4GB DDR3L memory, 128G SSD Storage, M12 connectors, DC 24V power input, no adaptor
MPPC1501PCH	15" EN50155 Certified Panel PC, Intel® Atom® x7-E3950 Processor, 4GB DDR3L memory, 128G SSD Storage, M12 connectors, DC 72/110V power input, no adaptor

Dimensions

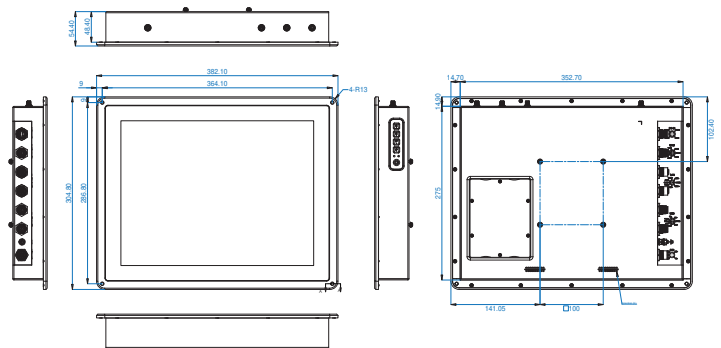



Features

- Intel® Atom® x6425E processor
- EN50155 (2017) & EN45545-2 certified
- Fully IP65 waterproof protection
- Supports ultra-long-life LCD panel, M12 connectors
- Flat bezel design, projected capacitive 12.1" touch screen
- Optional Auto dimming adjustable
- Supports 24V DC or 72/110V DC power input



Specifications

CPU Type	Intel® Atom® QC x6425E Processor, 2.0GHz , up to 3.0GHz
Memory	2x DDR4-3200 4GB, Max 32GB
Display Size	12.1" TFT-LCD
Max. Resolution	1024x768
Luminance (cd/m2)	500
Contrast	1000:1
Max. Color	16.2M
View Angle (H°/V°)	176/176
Backlight Lifetime(hrs)	30,000
Touch Type	Projected capacitive
Touch Interface	USB
Light Transmission (%)	86
Point of touch	10
I/O Interface	2x M12 X-code 8P GbE 2x M12 D-code 4P USB 2.0 1x M12 A-code 8P RS232/422/485 1x M12 A-code 8P DIO (4in/2out) 1x M12 A-code 4P DC-input 1x M12 A-code 2P remote control 1x M4 size earth grounding
Power Button	Membrane key
Power Input Range	DC24V or DC 72V/110V
Membrane Control	Brightness up/down, volume up/down, power on/off
Audio	2x speakers for optional
Internal Expansion	1x Full sized Mini-PCI-E slot (USB2.0 + SATA +PCI-E(x1)) 1x M.2 E-Key 2230 socket (USB 2.0)
Wireless	Optional 4G and WiFi modules
Storage	1x 2.5" device bay for SSD
Thermal Design	Fanless
Construction	Aluminum
Chassis Color (Front/Back)	Black/Black
IP Rating	IP65
Mounting	VESA 100x100 Panel mount (IP65 front panel only)
Dimensions	335mm (W) x274mm (D) x69mm (H) 13.19"(W) x 10.79"(D) x 2.7"(H)
Net Weight	3.1 kg
Operating Temperature	-40°C ~70°C, with industrial-grade SSD, not included add-on cards

Storage Temperature	-40°C~85°C (-40°F~185°F)
Storage Humidity	5%~90% @40°C (non-condensing)
Certified	EN50155:2017 EN45545-2 CE/FCC class-A
Operating Systems	Windows 10 64bit Linux Kernel 4.X

Ordering Information

MPPC1201PC	12.1" EN50155 Certified Panel PC, Intel® Atom™ Processor x6425E, 4GB DDR4 memory, industrial-grade 64GB SSD, M12 connectors, DC 24V power input, no adaptor
MPPC1201PCH	12.1" EN50155 Certified Panel PC, Intel® Atom™ Processor x6425E, 4GB DDR4 memory, industrial-grade 64GB SSD, M12 connectors, DC 72/110V power input, no adaptor

Dimensions

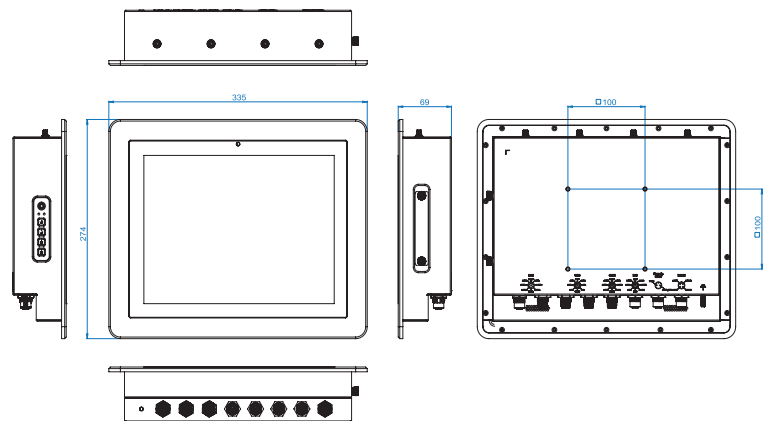



Features

- Intel® Atom® x7-E3950 Processor
- EN50155 (2017) & EN45545-2 certified
- Fully IP65 waterproof protection
- Supports ultra-long-life LCD panel, M12 connectors
- Flat bezel design, projected capacitive 10.4" touch screen
- Optional wireless communication
- Supports 24V DC or 72/110V DC power input
- Optional Auto dimming adjustable



Specifications

CPU Type	Intel® Atom® x7-E3950 Processor 1.6GHz, up to 2.0GHz
Memory	Max DDR3L 8GB, Default 4GB
Display Size	10.4"
Max. Resolution	1024x768
Luminance (cd/m ²)	500
Contrast	1000:1
Max. Color	16.2M
View Angle (H°/V°)	176/176
Backlight Lifetime(hrs)	50,000
Touch Type	Projected capacitive
Touch Interface	USB
Light Transmission (%)	89
Point of touch	10
I/O Interface	2x M12 A-code 8P GbE 2x M12 D-code 4P USB 2.0 1x M12 A-code 8P for RS-232/422/485 1x M12 A-code 4P DC-input
Power Button	Membrane key
Power Input Range	DC24V or DC 72V/ 110V
Membrane Control	Brightness up/down, volume up/down, power on/off
Audio	2x speakers
Internal Expansion	1x miniPCI-E (Full size) 1x miniPCI-E (Half size)
Wireless	Optional, Via miniPCI-E device
Storage	1x 2.5" HDD space, default 64GB SSD
Thermal Design	Fanless
Construction	Aluminums
Chassis Color (Front/Back)	Black/Black
IP Rating	IP65
Mounting	VESA 100x100/Rack mount
Dimensions	275mm(W) x 256mm(D) x 63mm(H) 10.8"(W) x 6.14"(D) x 2.48"(H)
Net Weight	4.3 kgs
Operating Temperature	-30°C ~ 70°C (-22°F ~ 158°F) with SSD, not including add-on cards
Storage Temperature	-40°C ~ 85°C (-40°F ~ 185°F)
Storage Humidity	10%~90% @40°C (non-condensing)
Certified	EN50155:2017, EN45545-2 CE/FCC class-A

Operating Systems	Windows 10 64bit/ Linux Kernel 4.X
-------------------	------------------------------------

Ordering Information

MPPC1001PC	10.4" EN50155 Certified Panel PC, Intel® Atom® x7-E3950 Processor, 4GB DDR3L memory, 64G SSD Storage, M12 connectors, DC 24V power input, no adaptor
MPPC1001PCH	10.4" EN50155 Certified Panel PC, Intel® Atom® x7-E3950 Processor, 4GB DDR3L memory, 64G SSD Storage, M12 connectors, DC 72/110V power input, no adaptor

Dimensions

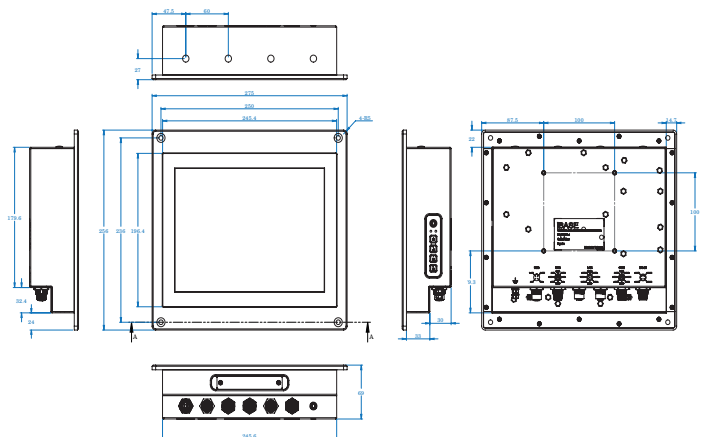



Features

- EN50155 certified
- Optical bonding
- Front bezel IP65 and full IP54 protection
- Movable and programmable membrane keypad
- 24V DC power input with M12 connector, 48V DC, 72V DC or 110V DC as options
- Two M12 LAN ports and one M12 USB port
- Additional rack mount kit



Specifications

CPU Type	Intel® Atom® Processor E3845 (Quad-Core 1.91GHz)
Memory	2x DDR3L SO-DIMM, up to 8GB, default DDR3L 4GB (4GBx1)
Display Size	12.1" TFT-LCD
Max. Resolution	1024 x 768
Luminance (cd/m ²)	500
Contrast	1000:1
Max. Color	16.7M
View Angle (H°/V°)	178/178
Backlight Lifetime(hrs)	30000
Touch Type	Projected capacitive
Touch Interface	USB
Light Transmission (%)	86
Point of touch	10
I/O Interface	1x USB 3.0 2x USB 2.0 (1x Type A and 1x M12 A-code 4P connector) 1x COM port for RS-232/422/485 2x GbE LAN ports, 2x 10/100 LAN with M12 connector 1x Display port 1x M12 A-code 4P DC-input
Power Button	Reset button
Power Input Range	24V DC (default) power input, Optional 72V DC & 110V DC
Membrane Control	Brightness up/down and Volume up/down/power button
Audio	2x Speakers
Internal Expansion	1x mPCI-E(x1) w/ USB signal [half-size] 1x mSATA/mPCI-E(x1) w/ USB signal and mSATA supports [full-size]
Wireless	Optional Wi-Fi/BT
Storage	1x 2.5" SATA
Thermal Design	Fanless
Construction	Aluminum front bezel and back cover
Chassis Color (Front/Back)	Silver/Silver
IP Rating	IP65 front bezel/ IP54 for whole unit with I/O cover
Mounting	Wall mount and VESA 75x75 mm

Dimensions	335 (W) x 267 (D) x 72.1 (H) mm 13.18" (W) x 10.5" (D) x 2.83" (H)
Net Weight	3.6 kgs
Operating Temperature	-30°C~70°C (-22 ~158 °F) (EN50155-TX)
Storage Temperature	-40°C ~ 85°C (-40 ~185 °F)
Storage Humidity	10%~90% (non-condensing)
Certified	EN50155: 2017, EN45545-2 CE/FCC Class-B
Operating Systems	Windows 10 32/64-bit, Windows 7 32/64-bit, Linux 3.x/4.x

Ordering Information

BYTEM-123-PC	12.1" (1024 x 768) Panel PC with IB897, Intel® Atom® Processor E3845 1.91GHz, 4GB DDR3L SO-DIMM, 64G SSD, projected capacitive touch, w/o power adaptor
Power adaptor (optional)	AC 100V~240V input, 24V DC output 90W power adaptor, IBASE P/N: A005PS090W0100600P

Dimensions

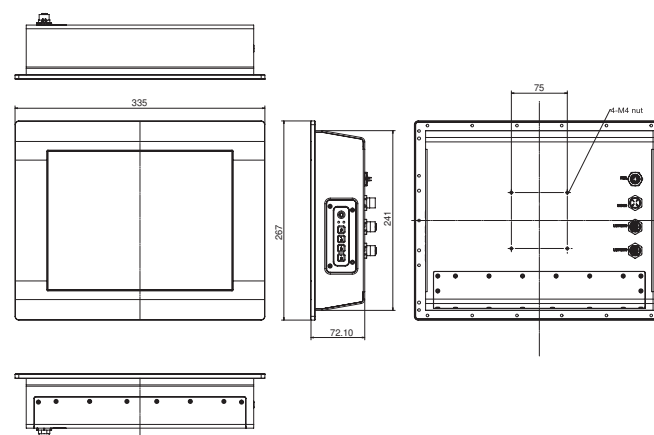



Features

- EN50155 certified
- Front bezel IP65 and full IP54 protection
- Full flat bezel design
- One M12 LAN port
- 24V DC power input with M12 connector, 48V DC, 72V DC or 110V DC as options
- Programmable membrane keypad
- Additional rack mount kit



Specifications

CPU Type	Intel® Atom® Processor E3845 (Quad-Core @ 1.91GHz)
Memory	2x DDR3L SO-DIMM, up to 8GB, default DDR3L 4GB (4GBx1)
Display Size	10.4" TFT-LCD
Max. Resolution	1024 x 768
Luminance (cd/m ²)	500
Contrast	1000:1
Max. Color	16.2M
View Angle (H°/V°)	176/176
Backlight Lifetime(hrs)	50000
Touch Type	Projected capacitive
Touch Interface	USB
Light Transmission (%)	85
Point of touch	2
I/O Interface	1x USB 3.0 1x USB 2.0 2x GbE LAN ports 1 x Display port 1x COM port for RS-232/422/485 1x M12 A-code 4P DC-input 1x 10/100 LAN with M12 connector
Power Button	Membrane key
Power Input Range	Default 24V DC input (EN50155 S2/C2), Optional 72V DC & 110V DC
Membrane Control	Brightness up/down and screen on/off/, power button
Audio	None
Internal Expansion	1x mPCI-E(x1) w/ USB signal [half-size] 1x mSATA/mPCI-E(x1) w/ USB signal and mSATA supports [full-size]
Wireless	None
Storage	1x 2.5" SATA
Thermal Design	Fanless
Construction	Aluminum front bezel and back cover
Chassis Color (Front/Back)	Silver/Silver
IP Rating	IP65 front bezel/ Others IP40 not including I/O cover/ IP54 for all with I/O cover
Mounting	Wall mount and VESA 75x75, 100x100 mm
Dimensions	275 (W) x 238.5 (D) x 78.5 (H) mm 10.82" (W) x 9.38" (D) x 3.09" (H)
Net Weight	4.3 kg

Operating Temperature	-30°C~70°C (-22 ~158 °F) (EN50155-TX)
Storage Temperature	-40°C ~ 85°C (-40 ~185 °F)
Storage Humidity	10%~90% (non-condensing)
Certified	EN50155, EN45545-2 CE/FCC Class-B
Operating Systems	Windows 10 32/64-bit, Windows 7 32/64-bit, Linux 3.x/4.x

Ordering Information

BYTEM-103-PC	10.4" (1024 x 768) Flat Panel Design Panel PC with IB897, Intel® Atom® Processor E3845 1.91GHz, 4GB DDR3L SO-DIMM, 64G SSD, projected capacitive touch, w/o power adaptor
Power adaptor (optional)	AC 100V~240V input, 24V DC output 90W power adaptor, IBASE P/N: A005PS090W0100600P

Dimensions

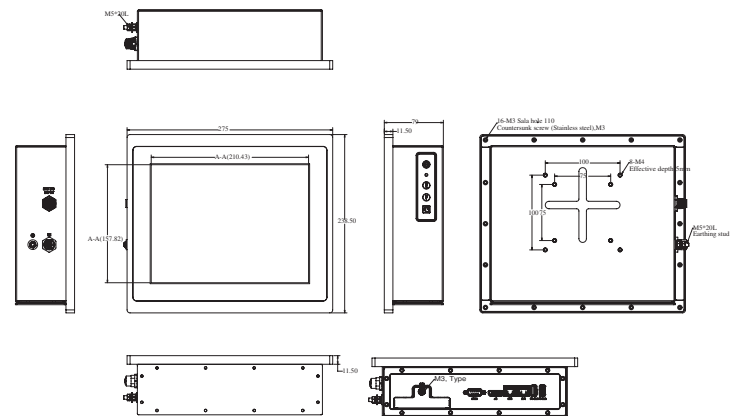

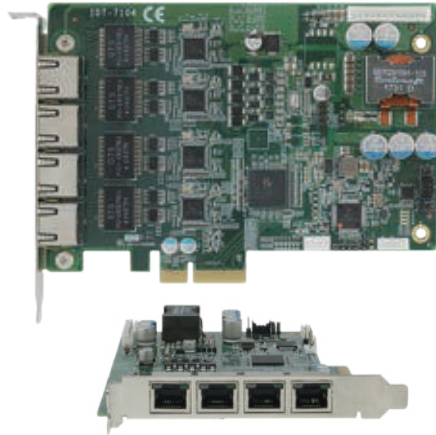

Features

- 4x PCI Express® compliant
- 4x independent Gigabit Ethernet ports supported
- IEEE 802.3af/at for Power over Ethernet supported
- IEEE 1588, PTP technology supported
- Link aggregation/jumbo frames (9 K-Byte) supported
- Operating temperature: -40°C ~ 70°C (-40°F ~ 158°F)

Specifications

Form Factor	4x PCI Express® compliant
Power Input	Maximal 10A @12VDC, directly from onboard power connector
LAN Chipset	Four Intel® i210IT Ethernet controllers
Cable Requirement	CAT-5e or CAT-6 cable, maximum 100 meters
Hipot	1.5 KV
Surge	±2KV surge protection
PoE Power Output	802.3af/at compliant (802.3AT type 1,2) Powered Device (PD) auto detection Power Level Classification: Class 1, 2, 3, 4 25.5W@48VDC power output (per powered-device)
Conformity	CE, FCC Class-A, RoHS
Operating Temperature	-40°C ~ 70°C (-40°F ~ 158°F)
Storage Temperature	-35°C ~ 85°C (-31°F ~ 185°F)
Operating Humidity	10%~95% @ 45°C (non-condensing)
Dimensions	155 x 111 mm (6.10" x 4.37")
Power Consumption	Max. 120W w/ 4x PoE power load
Construction	Aluminum
Operating System	XPe / W7 Pro/ WE8 STD / Ubuntu 11.10 above / Linux distributions with kernel 3.0 above

Ordering Information

IDT-7104	4-channel PoE card with power cable
----------	-------------------------------------

Dimensions

