

AL053

Atom

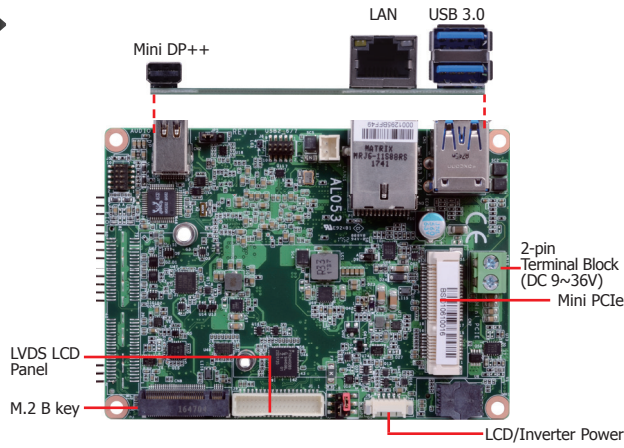

Top View

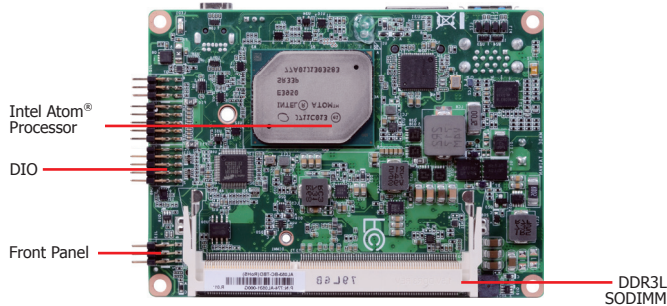

Bottom View

Features

- Small form factor 2.5" Pico-ITX for space-limited applications
- 1 DDR3L SODIMM up to 8GB
- Two independent displays: LVDS + Mini DP++
- Expansion and Storage: 1 Mini PCIe, 1 M.2, 1 SMBus
- Rich I/O: 1 Intel GbE, 1 COM, 2 USB 3.0, 2 USB 2.0

* Populated by default



Mechanical Drawing



Block Diagram

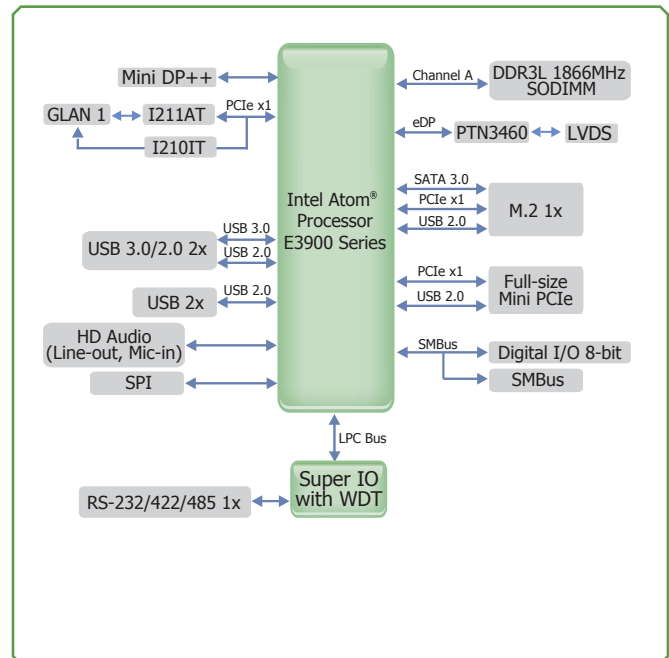

Specifications

SYSTEM	Processor	Intel Atom® Processor E3900 Series, BGA 1296 Intel Atom® x7-E3950 Processor, Quad Core, 2M Cache, 1.6GHz (2.0GHz), 12W Intel Atom® x5-E3940 Processor, Quad Core, 2M Cache, 1.6GHz (1.8GHz), 9.5W Intel Atom® x5-E3930 Processor, Dual Core, 2M Cache, 1.3GHz (1.8GHz), 6.5W Intel® Pentium® Processor N4200, Quad Core, 2M Cache, 1.1GHz (2.5GHz), 6W Intel® Celeron® Processor N3350, Dual Core, 2M Cache, 1.1GHz (2.4GHz), 6W
	Memory	One 204-pin SODIMM up to 8GB Single Channel DDR3L 1866MHz
	BIOS	Insyde SPI 64Mbit
GRAPHICS	Controller	Intel® HD Graphics
	Feature	OpenGL 4.2, Direct X 11.1, OpenCL 1.2, OGL ES 3.0 HW Decode: H.264, MPEG2, VC1, VP8, H.265, MPEG4 HW Encode: H.264, MPEG2, MPEG4
	Display	1 x Mini DP++ 1 x LVDS Mini DP++: resolution up to 4096x2160 @ 60Hz LVDS: dual channel 18/24-bit, resolution up to 1920x1200 @ 60Hz
	Dual Displays	LVDS + Mini DP++
EXPANSION	Interface	1 x Full-size Mini PCIe (PCIe/USB 2.0)
Storage	Storage	1 x M.2 B key 2242 (PCIe/USB 2.0/SATA 3.0)
AUDIO	Audio Codec	Realtek ALC262-VC2-GR
ETHERNET	Controller	1 x Intel® I211AT PCIe (10/100/1000Mbps) or 1 x Intel® I210IT PCIe (10/100/1000Mbps)
REAR I/O	Ethernet	1 x GbE (RJ-45)
	USB	2 x USB 3.0
	Display	1 x Mini DP++
INTERNAL I/O	Serial	1 x RS-232/422/485 (1.27mm pitch, right angle type)
	USB	2 x USB 2.0 (1.27mm pitch)
	Display	1 x LVDS LCD Panel Connector 1 x LCD/Inverter Power
	Audio	1 x Audio (Line-out/Mic-in)
	DIO	1 x 8-bit DIO
	SMBus	1 x SMBus
WATCHDOG TIMER	Output & Interval	System Reset, Programmable via Software from 1 to 255 Seconds
SECURITY	TPM	fTPM 2.0
POWER	Type	9~36V DC
	Connector	2-pin Terminal Block
	RTC Battery	CR2032 Coin Cell
OS SUPPORT	Microsoft/Linux	Windows 10 IoT Enterprise 64-bit Ubuntu 16.04
ENVIRONMENT	Temperature	Operating: 0 to 60°C, -20 to 70°C, -40 to 85°C Storage: -40 to 85°C
	Humidity	Operating: 5 to 90% RH Storage: 5 to 90% RH
MECHANICAL	Dimensions	2.5" Pico-ITX Form Factor 100mm (3.94") x 72mm (2.83")
	Height	PCB: 1.6mm Top Side: 15mm, Bottom Side: 8mm