



Features

- Fanless Design
- Intel® Atom D2550 1.8G Processor
- Onboard DDR3 2GB, option 4G
- 11~32V DC wide-ranging power input
- 5 sides IP65
- 5-Wire Resistive Touch Screen



Specifications

System

| | |
|----------------|--------------------------------------|
| Processor | Intel Atom D2550 1.8G Processor |
| System Chipset | Intel NM10 Express |
| System Memory | Onboard DDR3 2GB(Default), option 4G |

IO Port

| | |
|------------------|--|
| USB | 2 x USB 2.0 type A |
| Serial/Paralle | 1 x RS-232/422/485 selectable default RS-485 DB9 (COM 1) 1 x RS-232 DB9 (COM 2) |
| Audio | 1 x Line out, phone jack |
| Graph | None |
| LAN | 2 x GbE RJ-45 |
| Digital I/O | None |
| KB/MS | None |
| Membrane control | None |
| Power | 1 x 3 pins terminal block connector 1 x Power switch |
| TB-528C1U2PS1 | 2 x USB 1 x RS-232 (COM 5) |

Storage Space

| | |
|----------------|-------------------------------|
| HDD | 1 x 2.5" HDD space |
| Movable device | 1 x Internal SD slot on board |

Expansion

| | |
|------------------------|--|
| On board expansion bus | 1 x Mini PCIe half size Option wifi/BT with Antenna |
|------------------------|--|

Display

| | |
|--------------------------------|-------------|
| Display Type | 15" TFT-LCD |
| Max. Resolution | 1024x768 |
| Max. Color | 16M |
| Luminance (cd/m ²) | 400 |
| View Angle | 160/145 |
| Contrast | 800:1 |
| Backlight Lifetime | 50,000 |

Dimensions

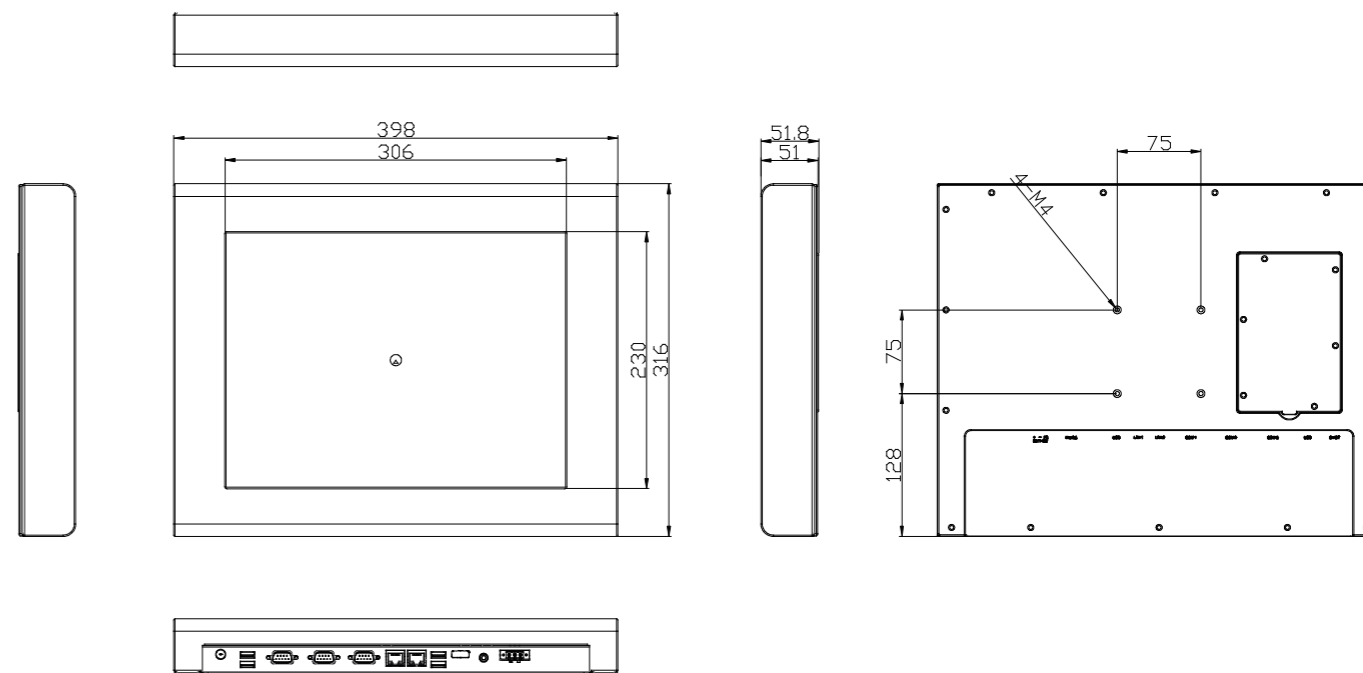

Touch Screen

| | |
|------------------------|-----------------|
| Type | Resistive Touch |
| Interface | Default RS-232 |
| Light transmission (%) | 80% |

Power

| | |
|-------------------|------------|
| Power input | 11~32V DC |
| Power Consumption | Max: 21.7W |

Mechanical

| | |
|------------------|------------------|
| Construction | Stainless Steel |
| IP Rating | 5 sides IP65 |
| Mounting | VESA 75 x 75 |
| Dimension (mm) | 398 x 316 x 51.8 |
| Net Weight (Kgs) | 6.9 |

Environmental

| | |
|---------------------------|--|
| Operating temperature(°C) | 0~50°C (with HDD) -20~60°C (with Industrial SSD) Optional |
| Storage temperature(°C) | -30~70°C |
| Storage humidity | 10 to 90% @ 40°C, non-condensing |
| Certification | CE/FCC class A |

Operating System Support

Microsoft Windows 7 pro for embedded, Windows embedded standard 7

Ordering information

| | |
|---------------|---|
| APC-3584AT-01 | 15" XGA 5 sides IP65 Intel Atom D2550 fanless panel PC, 2GB DDR3 memory 2.5" SATA2 320GB HDD, DC 11~32V power input with adaptor, black steel enclosure |
|---------------|---|