

**Features**

- 15" New Generation Stainless Steel Panel PC
- 4th Generation Intel Core i3-4010U/i5-4300U Onboard Processor
- True Flat Front Bezel Design and Grade 304 Stainless Steel Enclosure (Grade 316 for Option)
- IP66/IP69K Rated with M12 Connectors
- Support Resistive Touch, Projected Capacitive Touch, and Glass
- Touch on/off Button on the Side Edge for Hygienic Cleaning
- Support Ergonomic Versatile Mounting: Yoke Mounting / Space-saving VESA 75 mm Mounting

**Specifications**

System		
CPU	Onboard 4th Gen Intel Core i3/i5 Processor	
System Chipset	SoC	
Memory	Onboard 4GB DDR3L SDRAM , up to 8GB(option)	
IO Port		
USB	1 x M12 8-pin for USB 2.0 with waterproof cover and chain	
Serial / Parallel	1 x M12 8-pin COM1, RS-232/422/485, default RS-232, with waterproof cover and chain	
LAN	1 x M12 8-pin for LAN with waterproof cover and chain	
Audio	1 x Touch on/off button on the side	
Power Connector	1 x M12 3-pin for DC power with waterproof cover and chain 1 x Power switch on the side	
Option	2 x optional blank M12 connector with waterproof cover and chain for selecting two from the following options: 2 x USB 2.0 1 x USB 3.0 1 x LAN (POE for option) 1 x COM 1 x CAN	
Storage Space		
HDD	1 x 2.5" SATA3 HDD	
Expansion		
Expansion Slot	1 x miniPCIe slot for WIFI/BT(optional), 4G/LTE(optional)	
RFID module	RFID module design on the front side(optional)	
Display		
	Standard	High Brightness Optional
Display Type	15" TFT-LCD	15" TFT-LCD
Max. Resolution	1024 x 768	1024 x 768
Max. Color	262K / 16.2M (optional)	262K / 16.2M (optional)
Luminance (cd/m <sup>2</sup> )	420	1000
View Angle	160(H) /160(V)	160(H) /150(V)
Contrast	800:1	800:1
Backlight Lifetime	30,000 hrs	30,000 hrs
Touch Screen		
Type	Resistive Touch (For R model) Projected Capacitive Touch (For P model) Glass (For G model)	
Interface	USB	
Light Transmission(%)	Resistive Touch : 80% Projected Capacitive : 90%	
Power		
Power Input	DC 9~36V	
Power Consumption	ViTAM-915P:29W	

**Dimensions**

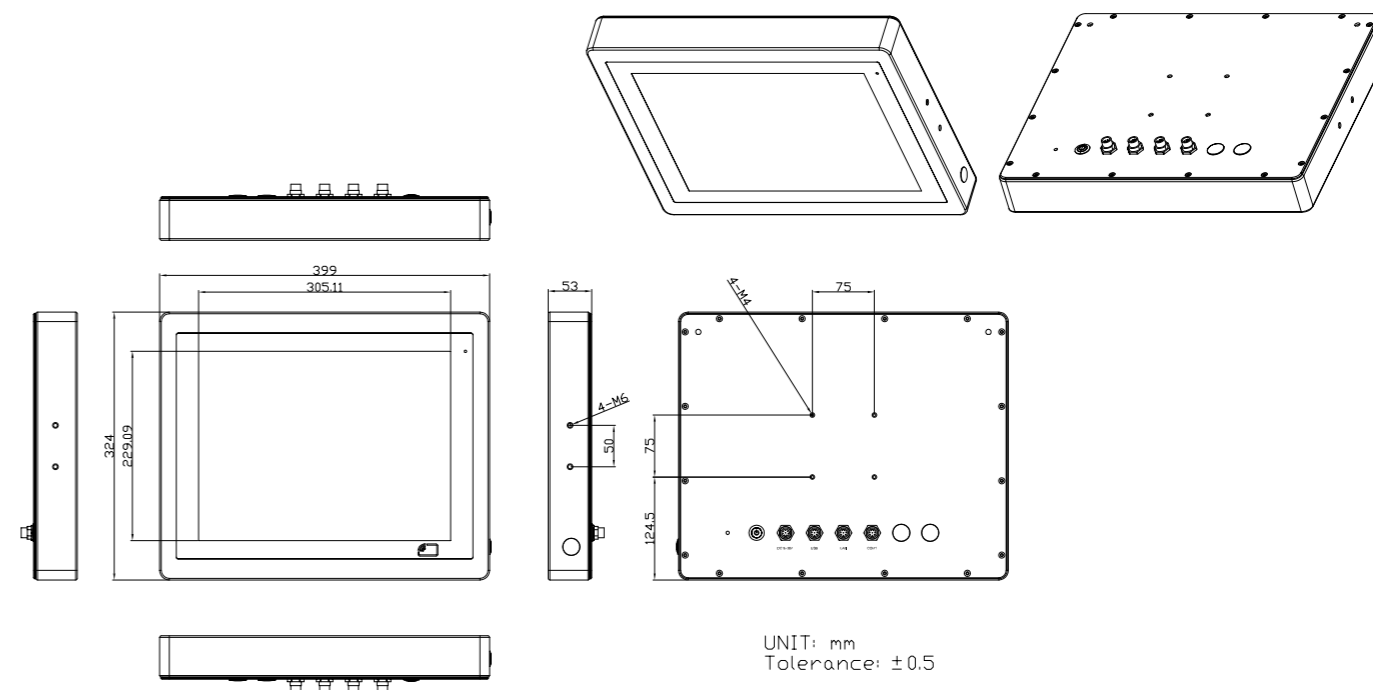

Mechanical	
Construction	304 Stainless steel chassis(default), 316 Stainless steel chassis(optional)
Mounting	VESA mount 75 x 75, Yoke mount for optional
IP Rating	Total IP66/IP69K
Dimensions	399 x 324 x 53 mm
Net Weight	7.1 kg
Environmental	
Operating Temperature	0 ~ 50°C
Storage Temperature	-30~70°C
Storage Humidity	10 to 90% @ 40°C, non- condensing
Certificate	CE/FCC Class A
Operating System Support	
WEC 7, Windows Embedded 7, Windows Embedded 8.1, Windows 10 IoT ENT LTSC	
Ordering Information	
ViTAM-915P	15" XGA IP66/IP69K stainless steel panel pc, Intel 4th Gen. Core i Processor, 4GB DDR3L RAM, 32G MLC SSD, projected capacitive touch, 9~36V DC power input with Adapter
ViTAM-915R	15" XGA IP66/IP69K stainless steel panel pc, Intel 4th Gen. Core i Processor, 4GB DDR3L RAM, 32G MLC SSD, 5 wire resistive touch window, 9~36V DC power input with Adapter
ViTAM-915G	15" XGA IP66/IP69K stainless steel panel pc, Intel 4th Gen. Core i Processor, 4GB DDR3L RAM, 32G MLC SSD, protection glass, 9~36V DC power input with Adapter
ViTAM-915PH	15" XGA IP66/IP69K stainless steel panel pc, Intel 4th Gen. Core i Processor, 4GB DDR3L RAM, 32G MLC SSD, projected capacitive touch, 9~36V DC power input with Adapter, 1,000 nits LCD
ViTAM-915RH	15" XGA IP66/IP69K stainless steel panel pc, Intel 4th Gen. Core i Processor, 4GB DDR3L RAM, 32G MLC SSD, 5 wire resistive touch window, 9~36V DC power input with Adapter, 1,000 nits LCD
ViTAM-915GH	15" XGA IP66/IP69K stainless steel panel pc, Intel 4th Gen. Core i Processor, 4GB DDR3L RAM, 32G MLC SSD, protection glass, 9~36V DC power input with Adapter, 1,000 nits LCD