

SI-60E

User Manual

Revision	Release Date
V1.0	2015/06/23
V1.1	2015/09/08
V1.2	2015/10/20
V1.3	2016/04/26
V1.4	2017/08/04

Copyright © 2013 IBASE Technology Inc. All Rights Reserved.

No part of this manual, including the products and software described in it, may be reproduced, transmitted, transcribed, stored in a retrieval system, or translated into any language in any form or by any means, except documentation kept by the purchaser for backup purposes, without the express written permission of IBASE Technology INC. ("IBASE ").

Products and corporate names mentioned in this manual may or may not be registered trademarks or copyrights of their respective companies, and are used for identification purposes only. All trademarks are the property of their respective owners.

Every effort has been made to ensure that the contents of this manual are correct and up to date. However, the manufacturer makes no guarantee regarding the accuracy of its contents, and reserves the right to make changes without prior notice.

Table of Contents

Setting up your system	5
Care during use	6
Acknowledgments	7
CHAPTER 1 INTRODUCTION.....	8
1.1 General Description	8
1.2 System Specifications	9
1.2.1 Hardware Specifications.....	9
1.2.2 Dimensions	10
1.2.3 I/O View	11
1.3 Exploded View of the SI-60E Assembly	12
1.3.1 Parts Description	13
1.4 Packing List.....	14
1.4.1 Optional Items module.....	14
1.5 HARDWARE INSTALLATION	15
1.5.1 Mounting Installation.....	15
1.5.2 Installing the storage.....	16
1.5.3 Installing the Rackmount.....	167
CHAPTER 2 MOTHERBOARD INTRODUCTION	18
2.1 Introduction.....	18
2.2 Installations.....	20
2.2.1 Installing the Memory.....	20
2.3 Setting the Jumpers	21
2.4 Connectors on MBD60E.....	23
CHAPTER 3 BIOS SETUP	29
3.1 BIOS Introduction	29
3.2 BIOS Setup	29
CHAPTER 4 DRIVERS INSTALLATION	53
4.1 Intel Chipset Software Installation Utility	53
4.2 AMD Radeon E8860 Graphics Driver	56
4.3 Realtek High Definition Audio Driver	60
4.4 Intel® I21x Gigabit Network Driver	62
4.5 Intel® Management Engine(ME) Driver	66
4.6 Intel® USB 3.0 eXtensible Host Controller Driver	69
4.7 Realtek RTL8111G LAN Driver.....	72
4.8 IDD100 Driver and Utility.....	74
Appendix	79
A. IBASE Display Matrix.....	79
B. IBASE Multiple-Display Matrix Technology Utility for Video Wall Display configuration setting.....	82
C. IDD100 LED Indicator Description.....	103
D. I/O Port Address Map.....	104
E. Interrupt Request Lines (IRQ)	105
F. Watchdog Timer Configuration	106

Safety Information

Your SI-60E is designed and tested to meet the latest standards of safety for information technology equipment. However, to ensure your safety, it is important that you read the following safety instructions

Setting up your system

- Read and follow all instructions in the documentation before you operate your system.
- Do not use this product near water.
- Set up the system on a stable surface. Do not secure the system on any unstable plane.
- Do not place this product on an unstable cart, stand, or table. The product may fall, causing serious damage to the product.
- Slots and openings on the chassis are for ventilation. Do not block or cover these openings. Make sure you leave plenty of space around the system for ventilation. ***Never insert objects of any kind into the ventilation openings.***
- This system should be operated from the type of power indicated on the marking label. If you are not sure of the type of power available, consult your dealer or local power company.
- Use this product in environments with ambient temperatures between 0°C and 45°C.
- If you use an extension cord, make sure that the total ampere rating of the devices plugged into the extension cord does not exceed its ampere rating.
- DO NOT LEAVE THIS EQUIPMENT IN AN ENVIRONMENT WHERE THE STORAGE TEMPERATURE MAY GO BELOW -20° C (-4° F) OR ABOVE 80° C (176° F). THIS COULD DAMAGE THE EQUIPMENT. THE EQUIPMENT SHOULD BE IN A CONTROLLED ENVIRONMENT.

Care during use

- Do not walk on the power cord or allow anything to rest on it.
- Do not spill water or any other liquids on your system.
- When the system is turned off, a small amount of electrical current still flows. Always unplug all power, and network cables from the power outlets before cleaning the system.
- If you encounter the following technical problems with the product, unplug the power cord and contact a qualified service technician or your retailer.
 - The power cord or plug is damaged.
 - Liquid has been spilled into the system.
 - The system does not function properly even if you follow the operating instructions.
 - The system was dropped or the cabinet is damaged.

Lithium-Ion Battery Warning

CAUTION: Danger of explosion if battery is incorrectly replaced. Replace only with the same or equivalent type recommended by the manufacturer. Dispose of used batteries according to the manufacturer's instructions.

NO DISASSEMBLY

The warranty does not apply to the products that have been disassembled by users

WARNING

HAZARDOUS MOVING PARTS

KEEP FINGERS AND OTHER BODY PARTS AWAY

Acknowledgments

- AMI is a registered trademark of AMI Software International, Inc.
- AMD and ATI are registered trademarks of AMD Corporation.
- Intel, Pentium, and Intel Core are registered trademarks or trademarks of Intel Corporation.
- Microsoft Windows is a registered trademark of Microsoft Corporation.
- FINTEK is a registered trademark of FINTEK Electronics Corporation.
- REALTEK is a registered trademark of REALTEK Electronics Corporation.
- All other product names or trademarks are properties of their respective owners.

-

CHAPTER 1 INTRODUCTION

1.1 General Description

The “Signature Book™” SI-60E is a professional digital signage system powered by 4th Gen. Intel® Core™ I Desktop Processors with AMD Radeon™ E8860 graphics. The SI-60E integrates 12 HDMI ports with EDID emulation function and one DVI-I for console use. Additionally, SI-60E has two quad-channel DDR3L-1600 sockets to provide up to 32GB of memory. It also has dual Gigabit Ethernet, dual extended SSD drive, Intel AMT for remote control and IBASE’s iSMART green technology for power on/off scheduling and power resume functions. The ruggedized design player’s chassis that provides passive cooling for better system reliability and quiet operation.



SI-60E overview

1.2 System Specifications

1.2.1 Hardware Specifications

Model Name	SI-60E
System Mainboard	MBD60E
CPU	4th Generation Intel® Core™ i7/i5/i3 and Pentium® QC/DC processors; Up to 3.5GHz
Memory	4x DDR3 1600 MHz, Max. 32GB
I/O Interface	12x HDMI with EDID emulation function 1x DVI-I for console 4x USB 3.0 ports 2x RJ45 for Gigabit LAN 1x DSUB 9 pin for RS-232/422/485 3x Microjack audio connectors for Line-in / Line-out/MIC-in Power LED for power on/off & HDD 1x power button 1x AC power inlet
Storage	1x mSATA 2x SATA 3.0 2.5" HDD Dock (support Raid 1)
Expansion Slots	Dual mPCI-E(x1) slots for WiFi, 3G/LTE, capture card and TV tuner options
Construction	SGCC
Mounting	Standard system bracket
Dimensions	412mm(W) x 310mm(D) x 47mm(H) 16.22"(W) x 12.2"(D) x 1.85"(H)
Operating Temperature	0°C~ 45°C (32°F~113°F)
Storage Temperature	-20°C ~ 80°C (-4°F~176°F)
Relative Humidity	5~90% @ 45°C, (non-condensing)
Vibration	mSATA: 5 grms / 5~500Hz / random operation
RoHS	Available
Certification	CE, FCC, CCC, UL

•This specification is subject to change without prior notice.

1.2.2 Dimensions

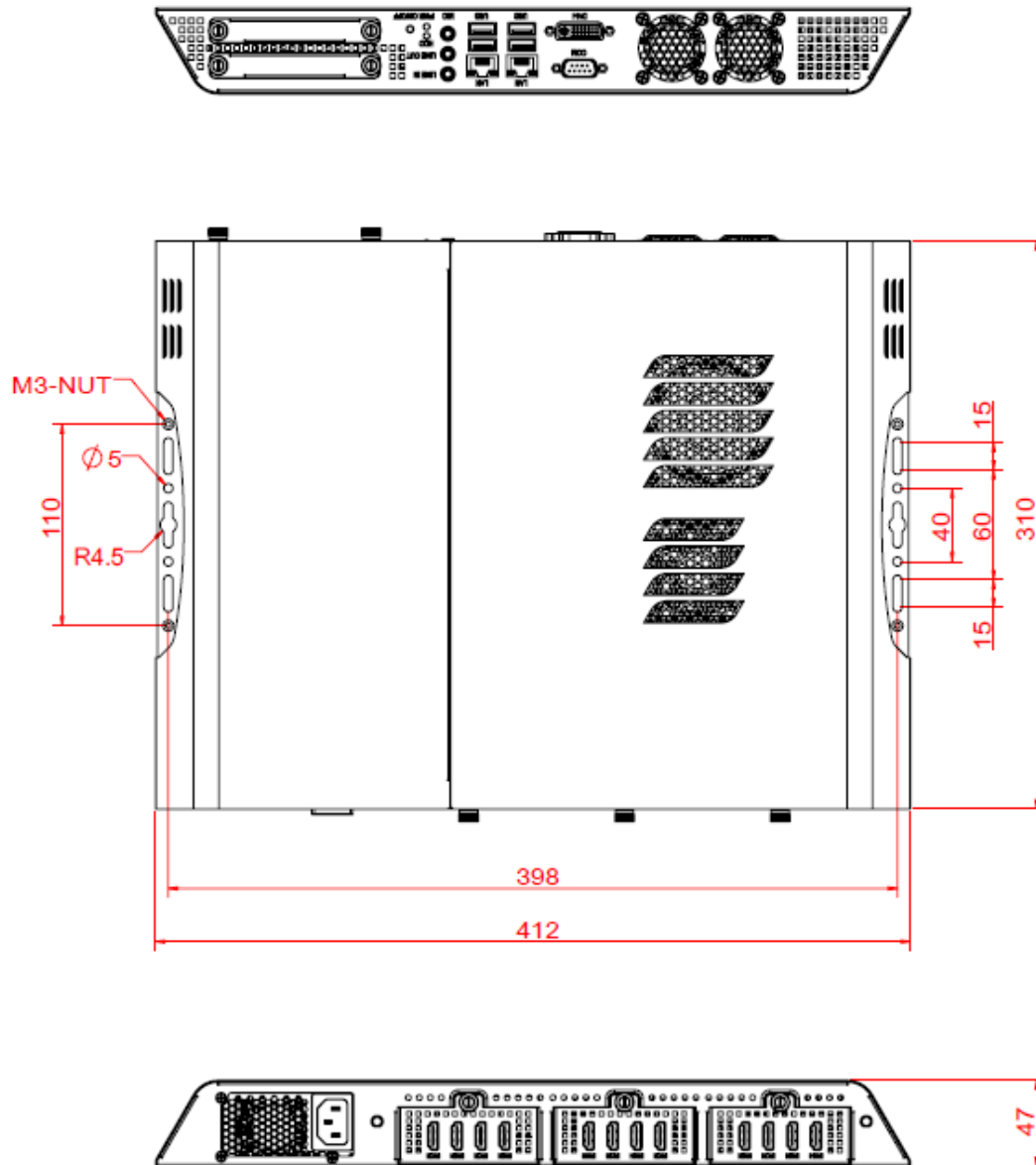

1.2.3 I/O View

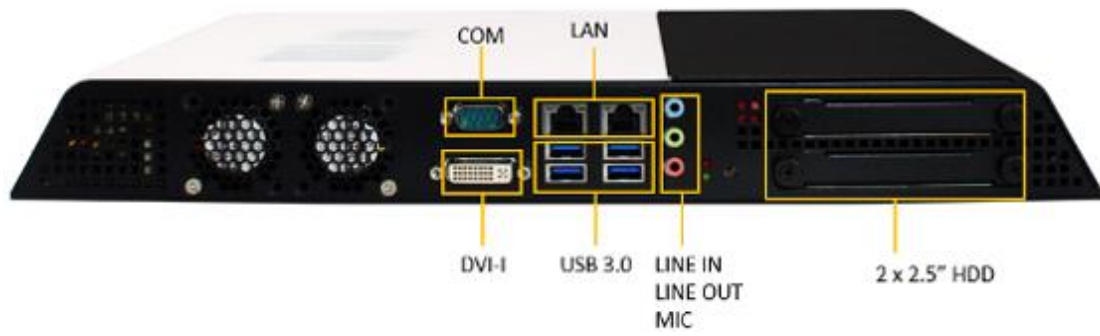

SI-60E front side



SI-60E rear side

1.3 Exploded View of the SI-60E Assembly

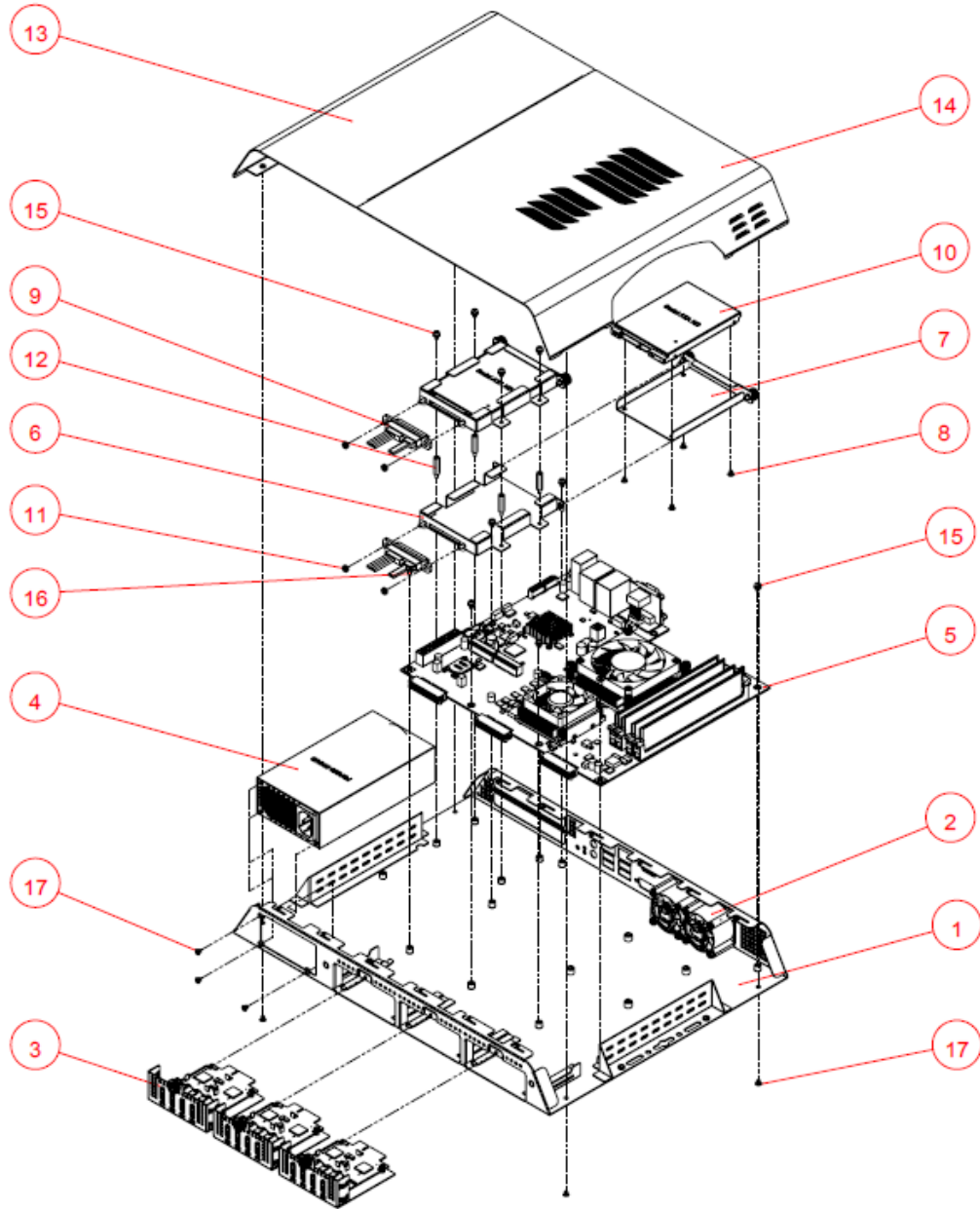





1.3.1 Parts Description

Part No.	Description	Part No.	Description
1	SI-60E_BASE	2	4028_fan
3	HDMI Board Module	4	Power module
5	SI-60E Main Board	6	SI-60E_HDD-TRAY
7	SI-60E_HDD-BRK	8	Screw F Type M3*0.5
9	SATA Cable	10	2.5" SATA HDD
11	M3 nut	12	M3 double screw bolt
13	SI-60E_top-cover_L	14	SI-60E_top-cover_r
15	Screw PW Type M3*0.5	16	M3 screw
17	Screw F Type M3*0.5 BK		

1.4 Packing List

Description	Qty
Driver CD	1
Power cord	1

1.4.1 Optional Items module

WiFi Solution	Description	
WiFi module	Wireless; PCI-E Mini Card 802.11B/G/N [AW-NE238H] (A008WLAWNE238H000P)	
External Antenna 2pcs	WiFi Antenna (A055RFA02C2M20800P)	
Internal cable 1pcs	Internal Antenna 300mm [BTC130-1-70B-300] RoHS (A055RFA0000020100P)	
Internal cable 1pcs	Internal Antenna 200mm [BTC130-1-70B-200-1] RoHS (A055RFA0000020000P)	
Screw, 2pcs	Screw; A44-N NI 3.4 NYLOK M2*L3.8 P0.4mm [LHS] RoHS (H02203A0442200N00P)	
Bracket, -1set	MPCI-E-EXT V-B2 Bracket (SC2MPCI-E-EXT0B2100P)	
3G Solution	Description	
3G	Wireless; 3.75G UMTS/HSPA [ZU202] RoHS (A008WIRELESS00520P)	
3G+GPS	Wireless; 3.75G UMTS/HSPA & GPS Module [ZU200] RoHS (A008WIRELESS00510P)	
WW-350U	Wireless; 3.75G UMTS/HSPA [NAVISYS WW-350U] RoHS (A008WIRELESS00530P)	
Cable	Cable; SMA IPX Cable For 3G 30CM [RF11030A] RoHS (A012INTENAL010000P)	
Antenna	3G [ANT0921Q2P] RoHS (A055ANT0921Q2P000P)	

1.5 HARDWARE INSTALLATION

1.5.1 Mounting Installation

1. Please install SI-60E to its intended location using 4x M4*0.7*6L screws, as shown in the picture.

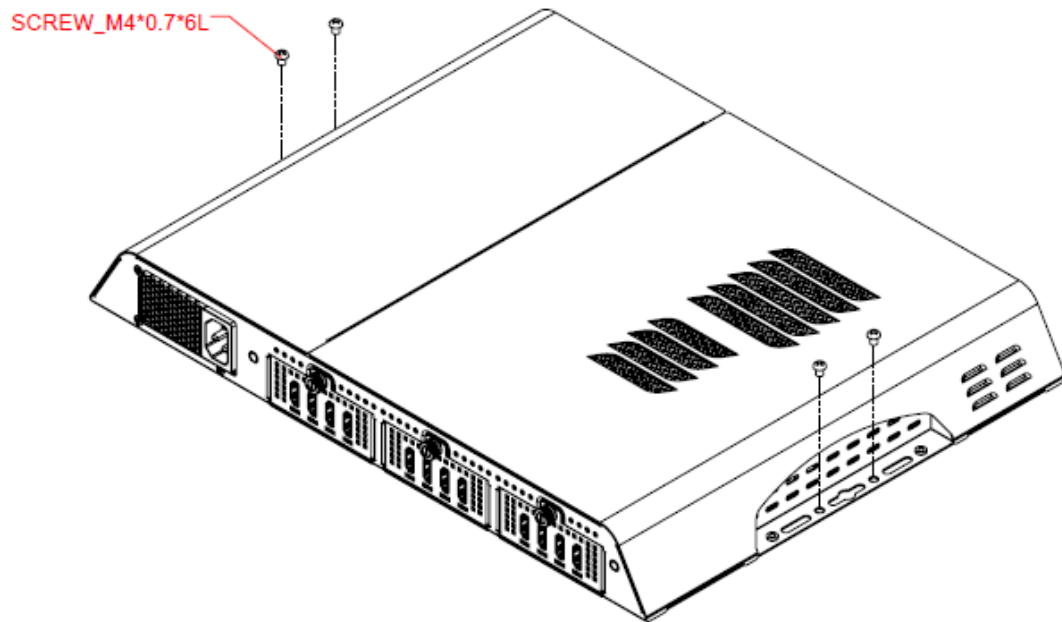

1.5.2 Installing the storage

1. Remove the two screws on the HDD cover and draw the HDD out.



2. Install the HDD/SSD to the HDD bracket with 4 screws.



1.5.3 Installing the Rackmount

1. Please install SI-60E to its intended location using 12x M3 screws, as shown in the picture

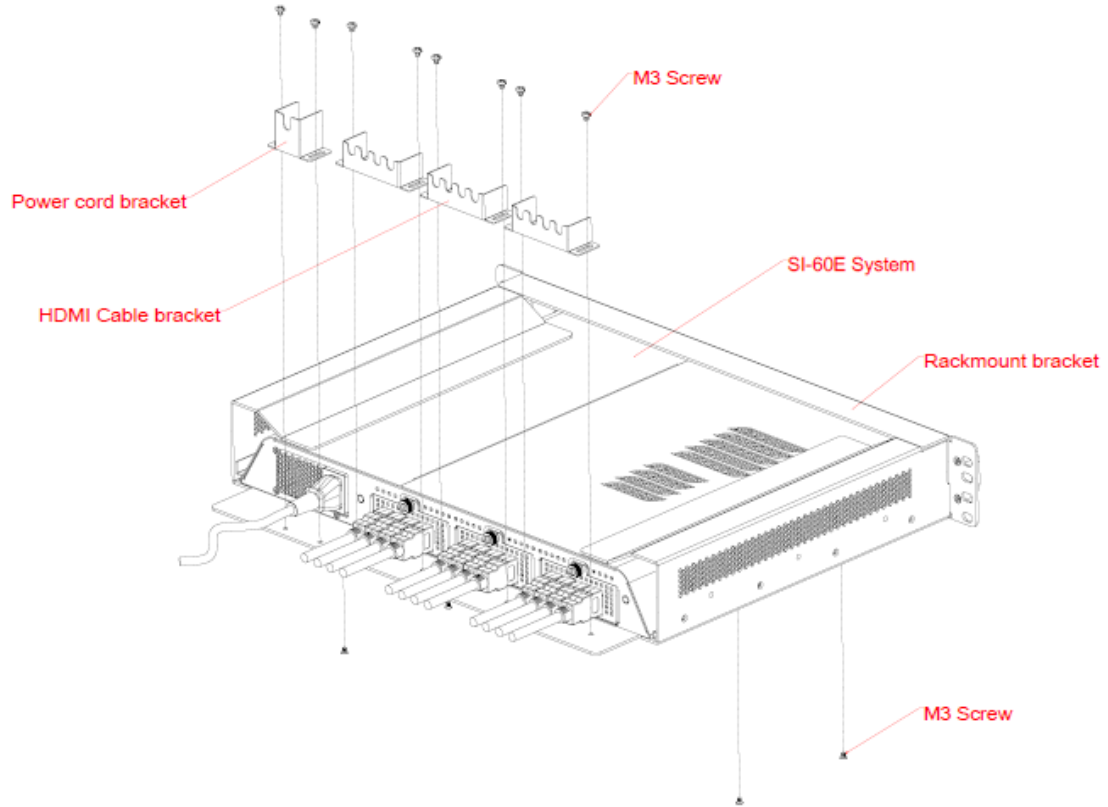

CHAPTER 2 MOTHERBOARD INTRODUCTION

2.1 Introduction

MBD60E Jumpers and Connectors

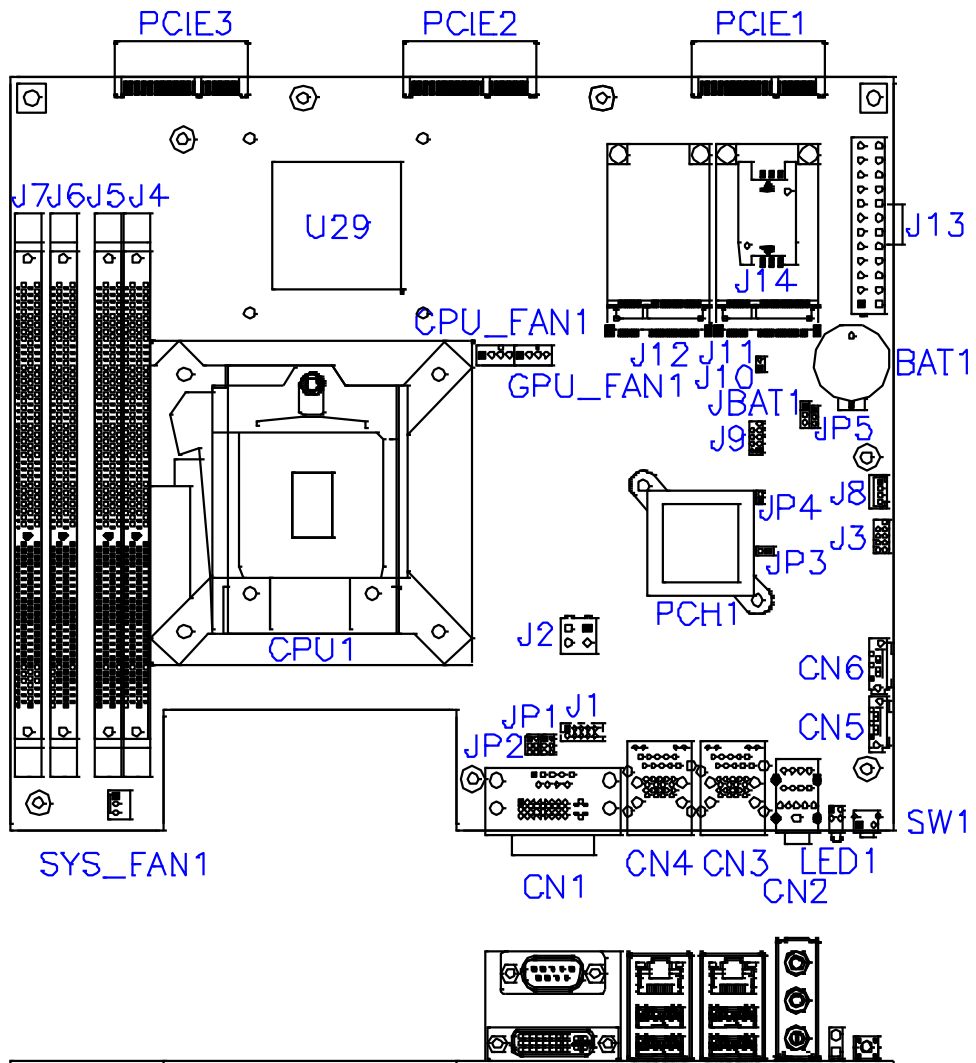

MBD60E Board Dimensions

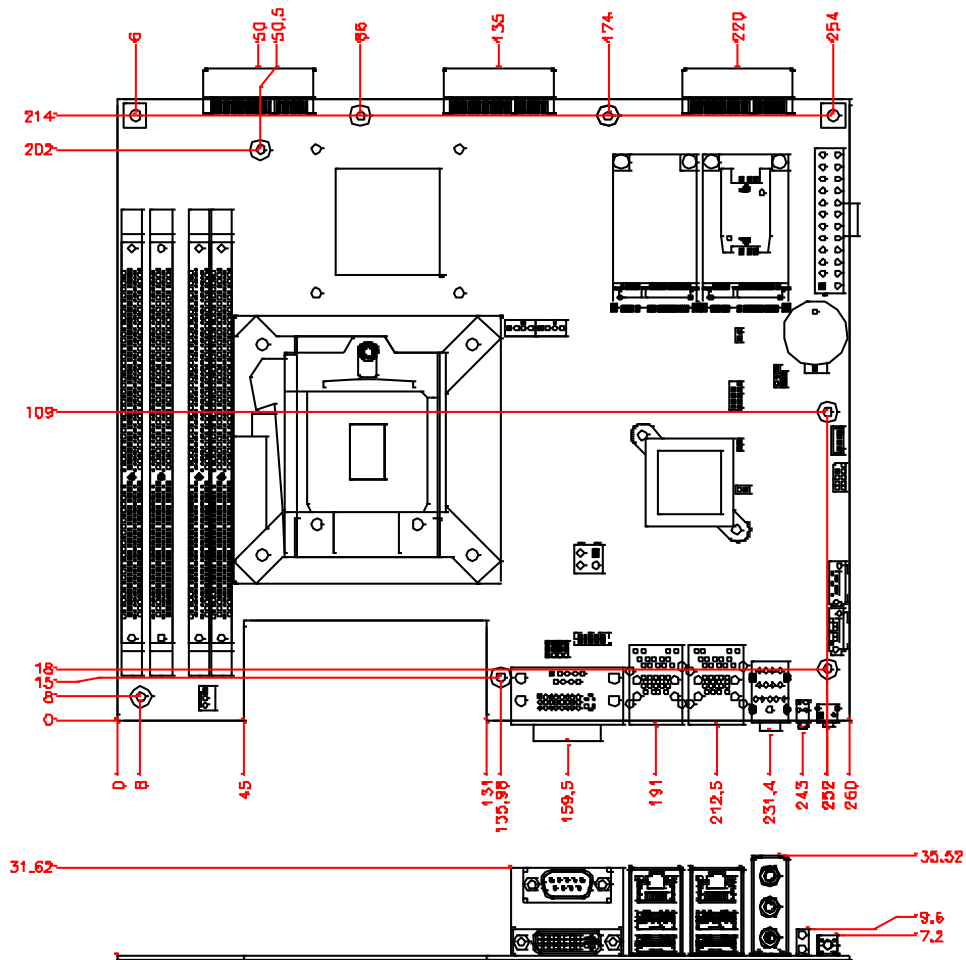

2.2 Installations

2.2.1 Installing the Memory

The MBD60E board supports four DDR3 memory modules for a maximum total of 32GB in DDR3 SODIMM memory type.

Installing and Removing Memory Modules

To install the DDR3 modules, locate the memory slot on the board and perform the following steps:

1. Hold the DDR3 module so that the key of the DDR3 module aligned with that on the memory slot.
2. Gently push the DDR3 module in an upright position until the clips of the slot close to hold the DDR3 module in place when the DDR3 module touches the bottom of the slot.
3. To remove the DDR3 module, press the clips with both hands.

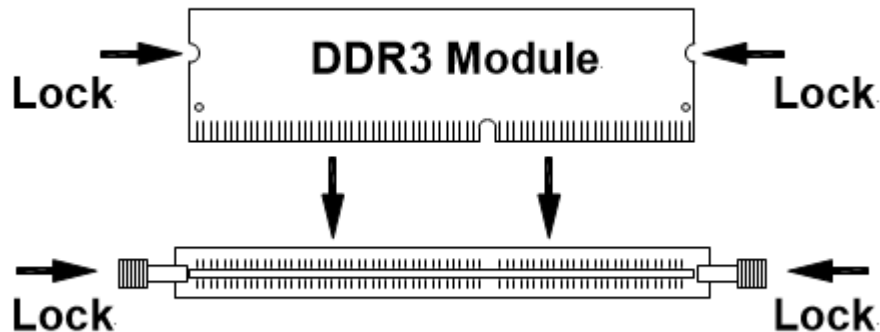



2.3 Setting the Jumpers

Jumpers are used on MBD60E to select various settings and features according to your needs and applications. Contact your supplier if you have doubts about the best configuration for your needs. The following lists the jumpers and connectors on MBD60E and their respective functions.

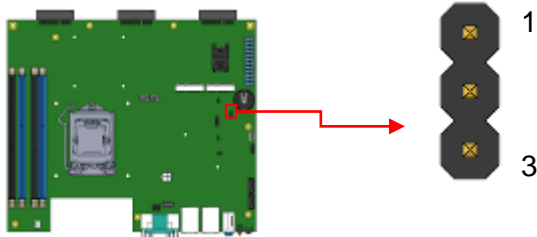
JBAT1: Clear CMOS Contents



JBAT1	Setting	Function
	Pin 1-2 Short/Closed	Normal
	Pin 2-3 Short/Closed	Clear CMOS

JP1: COM2 RS232 RI/+5V/+12V Power Setting

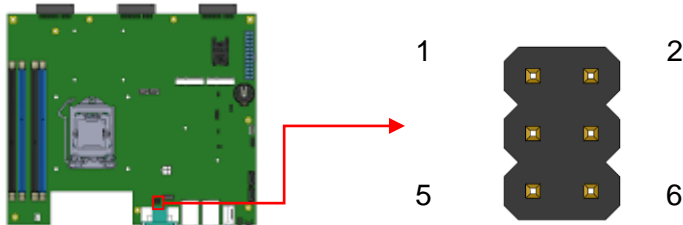

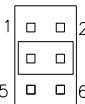
JP1	Setting	Function
	Pin 1-3 Short/Closed	+12V
	Pin 3-4 Short/Closed	RI
	Pin 5-3 Short/Closed	+5V

JP2: COM1 RS232 RI/+5V/+12V Power Setting

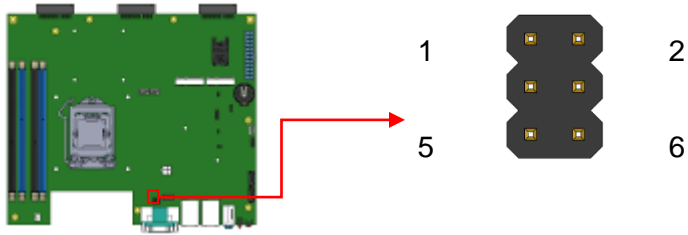

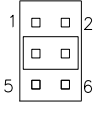
JP2	Setting	Function
	Pin 1-3 Short/Closed	+12V
	Pin 3-4 Short/Closed	RI
	Pin 5-3 Short/Closed	+5V

JP3: Flash Descriptor Security Override (Factory use only)

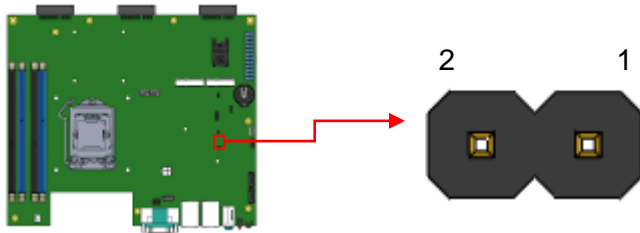

2.4 Connectors on MBD60E

J1: COM2 Connector [HRS DF11-10DP-2DSA(08)]

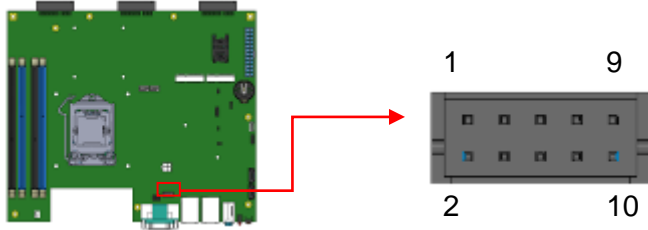

Signal Name	Pin #	Pin #	Signal Name
Data carrier detect	1	2	Receive data
Transmit data	3	4	Data terminal ready
Ground	5	6	Data set ready
Request to send	7	8	Clear to send
Ring indicator	9	10	Not Used

J2: ATX +12V Jack [HAOGUO ATX4PT-NY46]

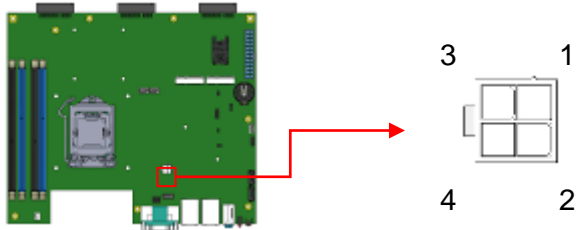

Pin #	Signal Name
1	Ground
2	Ground
3	DC_IN
4	DC_IN

J3: For SPI Debug tools Pin Header

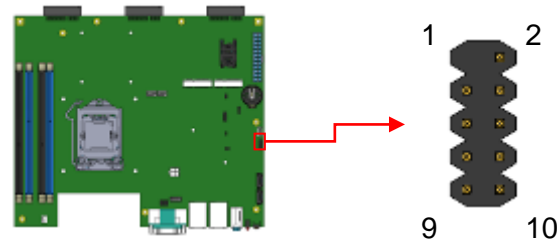

J4, J5, J6, J7 DDR III Socket

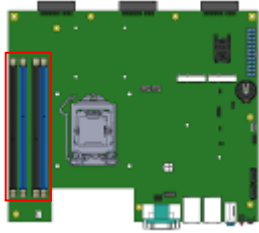

J8: MCU Flash Connector (Factory use only)

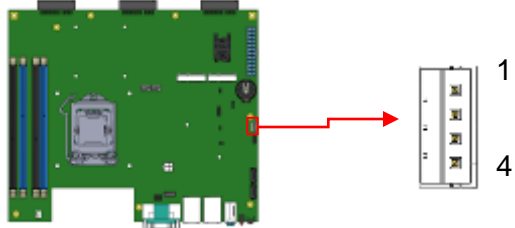

J9: Debug Port Connector (Factory use only)

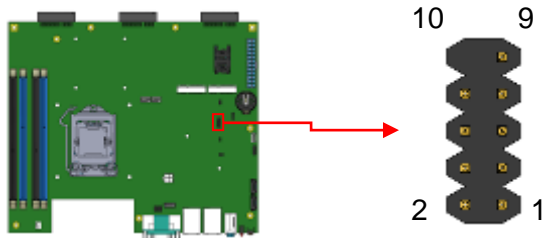

J10: Reset Pin Header

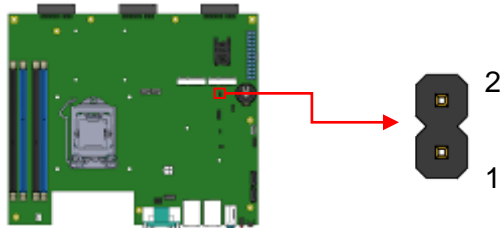

J11: Mini PCIe Slot (Full size with SIM Card)

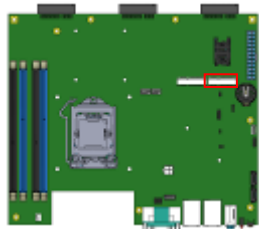

J12: Mini PCIe Slot (Full size with mSATA)

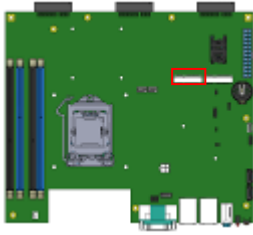

J13: ATX Power Supply Connector

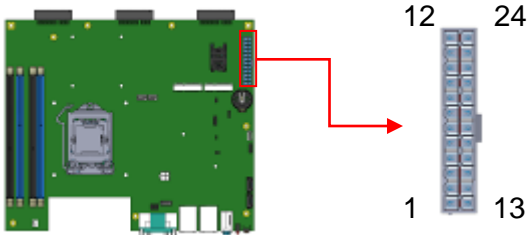

Signal Name	Pin #	Pin #	Signal Name
3.3V	13	1	3.3V
-12V	14	2	3.3V
Ground	15	3	Ground
PS-ON	16	4	+5V
Ground	17	5	Ground
Ground	18	6	+5V
Ground	19	7	Ground
-5V	20	8	Power good
+5V	21	9	5VSB
+5V	22	10	+12V
+5V	23	11	+12V
Ground	24	12	+3.3V

J14: SIM Card Slot

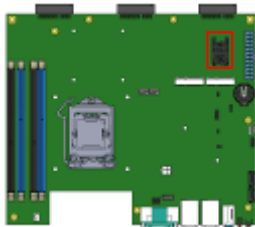

CN1: COM1 / DVI-I Connector

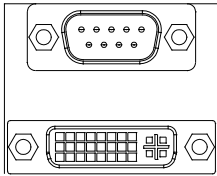

Signals of COM1 Connector:

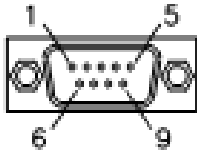

Pin #	Signal Name		
	RS-232	R2-422	RS-485
1	DCD	TX-	DATA-
2	RX	TX+	DATA+
3	TX	RX+	NC
4	DTR	RX-	NC
5	Ground	Ground	Ground
6	DSR	NC	NC
7	RTS	NC	NC
8	CTS	NC	NC
9	RI	NC	NC
10	NC	NC	NC

CN2: Audio Jack

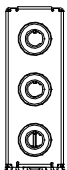

CN3: RTL8111G-CG /USB3.0 Connector

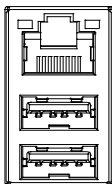

CN4: I218LM / USB3.0 Connector

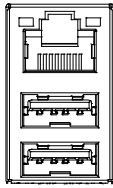

CN5/6: SATA 3 Connector

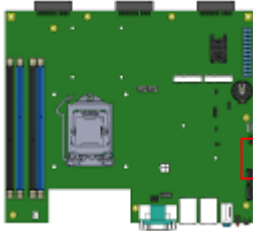

CPU_FAN1: CPU Fan Power Connector

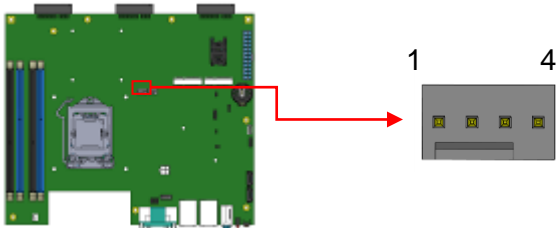

Pin #	Signal Name
1	Ground
2	+12V
3	Rotation detection
4	Control

GPU_FAN1: GPU Fan Power Connector

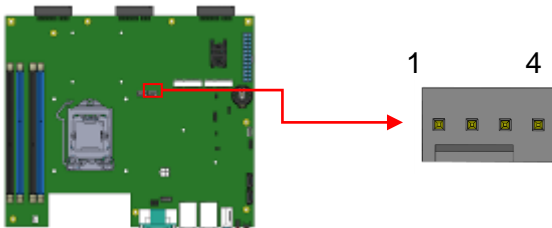

Pin #	Signal Name
1	Ground
2	+12V
3	Rotation detection
4	Control

SYS_FAN1: System Fan1 Power Connector

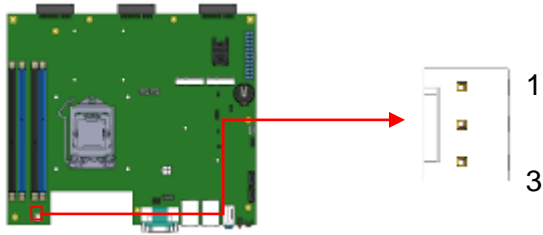

Pin #	Signal Name
1	Ground
2	+12V
3	Rotation detection

SW1: Power On Button

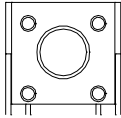

LED1: PWR (Green)/ HDD LED (Red)



PCIE1, PCIE2, PCIE3: DP Signal from AMD E8860 to IDD100

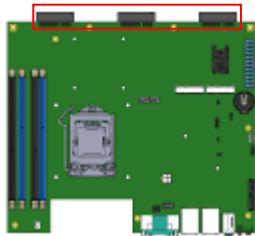

CHAPTER 3 BIOS SETUP

This chapter describes the different settings available in the AMI BIOS that comes with the board. The topics covered in this chapter are as follows:

3.1 BIOS Introduction

The BIOS (Basic Input/Output System) installed in your computer system's ROM supports Intel processors. The BIOS provides critical low-level support for a standard device such as disk drives, serial ports and parallel ports. It also password protection as well as special support for detailed fine-tuning of the chipset controlling the entire system.

3.2 BIOS Setup

The BIOS provides a Setup utility program for specifying the system configurations and settings. The BIOS ROM of the system stores the Setup utility. When you turn on the computer, the BIOS is immediately activated. Pressing the key immediately allows you to enter the Setup utility. If you are a little bit late pressing the key, POST (Power On Self Test) will continue with its test routines, thus preventing you from invoking the Setup. If you still wish to enter Setup, restart the system by pressing the "Reset" button or simultaneously pressing the <Ctrl>, <Alt> and <Delete> keys. You can also restart by turning the system Off and back On again. The following message will appear on the screen:

```
Press <DEL> to Enter Setup
```

In general, you press the arrow keys to highlight items, <Enter> to select, the <PgUp> and <PgDn> keys to change entries, <F1> for help and <Esc> to quit.

When you enter the Setup utility, the Main Menu screen will appear on the screen. The Main Menu allows you to select from various setup functions and exit choices.

Warning: *It is strongly recommended that you avoid making any changes to the chipset defaults. These defaults have been carefully chosen by both AMI and your system manufacturer to provide the absolute maximum performance and reliability. Changing the defaults could cause the system to become unstable and crash in some cases.*

Main Settings

Aptio Setup Utility – Copyright © 2012 American Megatrends, Inc.

Main	Advanced	Chipset	Boot	Security	Save & Exit
System Language		[English]			
System Date		[Tue			
System Time		01/20/2009]			
Access Level		[21:52:06]			
		Administrator			

→ ←Select Screen
↑ ↓Select Item
Enter: Select
+- Change Opt.
F1: General Help
F2: Previous Values
F3: Optimized Defaults
F4: Save & Exit
ESC: Exit

System Language

Choose the system default language.

System Date

Set the Date. Use Tab to switch between Data elements.

System Time

Set the Time. Use Tab to switch between Data elements.

Advanced Settings

This section allows you to configure and improve your system and allows you to set up some system features according to your preference.

Aptio Setup Utility – Copyright © 2012 American Megatrends, Inc.

Main	Advanced	Chipset	Boot	Security	Save & Exit
▶ ACPI Settings					
▶ Trusted Computing					
▶ Wake up event setting					
▶ CPU Configuration					
▶ SATA Configuration					
▶ Shutdown Temperature Configuration					
▶ iSmart Controller 3.1					
▶ AMT Configuration					
▶ USB Configuration					
▶ F81846 Super IO Configuration					
▶ F81846 H/W Monitor					
					← Select Screen ↑ ↓ Select Item Enter: Select +- Change Opt. F1: General Help F2: Previous Values F3: Optimized Defaults F4: Save & Exit ESC: Exit

ACPI Settings

Aptio Setup Utility - Copyright © 2012 American Megatrends, Inc.

Main	Advanced	Chipset	Boot	Security	Save & Exit
ACPI Settings					→ ←Select Screen ↑ ↓ Select Item Enter: Select +- Change Opt. F1: General Help F2: Previous Values F3: Optimized Defaults F4: Save & Exit ESC: Exit
ACPI Sleep State		S3 only (Suspend to ...)			
Lock Legacy Resources		Disabled			
S3 Video Repost		Disabled			

ACPI Sleep State

Select ACPI sleep state the system will enter when the SUSPEND button is pressed.

Lock Legacy Resources

Enables or Disables Lock of Legacy Resources

S3 Video Repost

Enable or Disable S3 Video Repost

Trusted Computing

Aptio Setup Utility - Copyright © 2012 American Megatrends, Inc.

Main	Advanced	Chipset	Boot	Security	Save & Exit
Configuration					
Security Device Support			Disabled		
Current Status Information					
SUPPORT TURNED OFF					

→ ←Select Screen
↑ ↓Select Item
Enter: Select
+- Change Opt.
F1: General Help
F2: Previous Values
F3: Optimized Defaults
F4: Save & Exit
ESC: Exit

Security Device Support

Enables or disables BIOS support for security device. O.S. will not show Security Device. TCG EFI protocol and INT1A interface will not be available.

TPM State

Enable/Disable Security Device. NOTE: Your Computer will reboot during restart in order to change State of the Device.

Pending operation

Schedule an Operation for the Security Device. NOTE: Your Computer will reboot during restart in order to change State of Security Device.

Wake up event settings

Aptio Setup Utility - Copyright © 2012 American Megatrends, Inc.

Main	Advanced	Chipset	Boot	Security	Save & Exit
Wake on PCIE Wake Event			Disabled	→ ←Select Screen ↑↓Select Item Enter: Select +- Change Opt. F1: General Help F2: Previous Values F3: Optimized Defaults F4: Save & Exit ESC: Exit	

Wake on PCIE Wake Event

The options are Disabled and Enabled.

CPU Configuration

This section shows the CPU configuration parameters.

Aptio Setup Utility - Copyright © 2012 American Megatrends, Inc.

Main	Advanced	Chipset	Boot	Security	Save & Exit
CPU Configuration					
Intel(R) Core(TM) i7-4770S CPU @ 3.10GHz					
CPU Signature		306c3			
Processor Family		6			
Microcode Patch		17			
FSB Speed		100 MHz			
Max CPU Speed		3100 MHz			
Min CPU Speed		800 MHz			
CPU Speed		3500 MHz			
Processor Cores		4			
Intel HT Technology		Supported			
Intel VT-x Technology		Supported			
Intel SMX Technology		Supported			
64-bit		Supported			
EIST Technology		Supported			
Hyper-threading		Enabled			
Active Processor Cores		All			
Overclocking lock		Disabled			
Limit CPUID Maximum		Disabled			
Execute Disable Bit		Disabled			
Intel Virtualization Technology		Disabled			
Hardware Prefetcher		Disabled			
Adjacent Cache Line Prefetch		Disabled			
EIST		Enabled			
Turbo Mode		Enabled			

→ ←Select Screen
 ↑ ↓Select Item
 Enter: Select
 +- Change Opt.
 F1: General Help
 F2: Previous Values
 F3: Optimized Defaults
 F4: Save & Exit
 ESC: Exit

Hyper-threading

Enabled for Windows XP and Linux (OS optimized for Hyper-Threading Technology) and Disabled for other OS (OS not optimized for Hyper-Threading Technology). When Disabled only one thread per enabled core is enabled.

Active Processor Cores

Number of cores to enable in each processor package.

Overclocking lock

FLEX_RATIO(194) MSR

Limit CUID Maximum

Disabled for Windows XP

Execute Disable Bit

XD can prevent certain classes of malicious buffer overflow attacks when combined with a supporting OS (Windows Server 2003 SP1, Windows XP SP2, SuSE Linux 9.2, RedHat Enterprise 3 Update 3.)

Intel Virtualization Technology

When enabled, a VMM can utilize the additional hardware capabilities provided by Vanderpool Technology

Hardware Prefetcher

Enable the Mid Level Cache (L2) streamer prefetcher.

Adjacent Cache Line Prefetch

Enable the Mid Level Cache (L2) prefetching of adjacent cache lines.

EIST

Enable/Disable Intel Speedstep

Turbo Mode

Turbo Mode.

SATA Configuration

Aptio Setup Utility - Copyright © 2012 American Megatrends, Inc.

Main	Advanced	Chipset	Boot	Security	Save & Exit
SATA Controller(s)		Enabled			
SATA Mode Selection		AHCI			
SATA Controller Speed		Default			
Serial ATA Port 0		Empty			
Software Preserve		Unknown			
Port 0		Enabled			
Hot Plug		Disabled			
Serial ATA Port 1		Empty			
Software Preserve		Unknown			
Port 1		Enabled			
Hot Plug		Disabled			
Serial ATA Port 2		Empty			
Software Preserve		Unknown			
Port 2		Enabled			
Hot Plug		Disabled			
Serial ATA Port 3		Empty			
Software Preserve		Unknown			
Port 3		Enabled			
Hot Plug		Disabled			
Serial ATA Port 4		Empty		→ ←Select Screen	
Software Preserve		Unknown		↑ ↓Select Item	
Port 4		Enabled		Enter: Select	
Hot Plug		Disabled		+- Change Opt.	
Serial ATA Port 5		Empty		F1: General Help	
Software Preserve		Unknown		F2: Previous Values	
Port 5		Enabled		F3: Optimized Defaults	
Hot Plug		Disabled		F4: Save & Exit	
				ESC: Exit	

SATA Controller(s)

Enable or disable SATA Device.

SATA Mode Selection

Determines how SATA controller(s) operate.

- (1) IDE Mode.
- (2) AHCI Mode.
- (3) RAID Mode.

SATA Controller Speed

Indicates the maximum speed the SATA controller can support.

Port 0

Enable or Disable SATA Port

Hot Plug

Designates this port as Hot Pluggable.

Shutdown Temperature Configuration

Aptio Setup Utility - Copyright © 2012 American Megatrends, Inc.

Main	Advanced	Chipset	Boot	Security	Save & Exit
ACPI Shutdown Temperature			Disabled		→ ←Select Screen ↑ ↓Select Item Enter: Select +- Change Opt. F1: General Help F2: Previous Values F3: Optimized Defaults F4: Save & Exit ESC: Exit

ACPI Shutdown Temperature

The default setting is Disabled.

iSmart Controller 3.1

Aptio Setup Utility - Copyright © 2012 American Megatrends, Inc.

Main	Advanced	Chipset	Boot	Security	Save & Exit
iSmart Controller 3.1					
Power-On after Power failure			Enable		→ ←Select Screen ↑ ↓Select Item Enter: Select +- Change Opt. F1: General Help F2: Previous Values F3: Optimized Defaults F4: Save & Exit ESC: Exit
PWR Resume Delay			Enable		
PWR Resume Delay Value(Seconds)			5		
Temperature Guardian			Disable		
Schedule Slot 1			None		
Schedule Slot 2			None		

Power-On after Power failure

This field sets the system power status whether Disable or Enable when power returns to the system from a power failure situation.

Temperature Guardian

Generate the reset signal when system hangs up on POST.

Schedule Slot 1 / 2

Setup the hour/minute for system power on.

AMT Configuration

Aptio Setup Utility - Copyright © 2012 American Megatrends, Inc.

Main	Advanced	Chipset	Boot	Security	Save & Exit
			Intel AMT	Enabled	
			BIOS Hotkey Pressed	Disabled	
			MEBx Selection Screen	Disabled	
			Hide Un-Configure ME Confirmation	Disabled	
			Un-Configure ME	Disabled	
			Amt Wait Timer	0	
			Activate Remote Assistance Process	Disabled	
			USB Configure	Enabled	
			PET Progress	Enabled	→ ←Select Screen
			AMT CIRA Timeout	0	↑ ↓Select Item
			Watchdog	Disabled	Enter: Select
			OS Timer	0	+ - Change Opt.
			BIOS Timer	0	F1: General Help
					F2: Previous Values
					F3: Optimized Defaults
					F4: Save & Exit
					ESC: Exit

Intel AMT

Enable/Disable Intel (R) Active Management Technology BIOS Extension.

Note: iAMT H/W is always enabled. This option just controls the BIOS extension execution.

If enabled, this requires additional firmware in the SPI device.

BIOS Hotkey Pressed

OEMFLag Bit 1:

Enable/Disable BIOS hotkey press.

AMT Configuration

OEMFLag Bit 2:

Enable/Disable MEBx selection screen.

Hide Un-Configure ME Configuration

OEMFlag Bit 6:

Hide Un-Configure ME without password Confirmation Prompt

Un-Configure ME

OEMFlag Bit 15:

Un-Configure ME without password.

Amt Wait Timer

Set timer to wait before sending ASF_GET_BOOT_OPTIONS.

Activate Remote Assistance Process

Trigger CIRA boot.

USB Configure

Enable/Disable USB Configure function.

PET Progress

User can Enable/Disable PET Events progress to receive PET events or not.

Watchdog Timer

Enable/Disable Watchdog Timer.

USB Configuration

Aptio Setup Utility - Copyright © 2012 American Megatrends, Inc.

Main	Advanced	Chipset	Boot	Security	Save & Exit
USB Configuration					
USB Module Version		8.10.28			
USB Devices:					
Legacy USB Support		Enabled			
USB3.0 Support		Enabled			
XHCI Hand-off		Enabled			
EHCI Hand-off		Enabled			
USB Mass Storage Driver Support		Enabled			
USB hardware delays and time-outs:				→ ←Select Screen	
USB Transfer time-out		20 sec		↑ ↓ Select Item	
Device reset time-out		20 sec		Enter: Select	
Device power-up delay		Auto		+- Change Opt.	
				F1: General Help	
				F2: Previous Values	
				F3: Optimized Defaults	
				F4: Save & Exit	
				ESC: Exit	

Legacy USB Support

Enables Legacy USB support.

AUTO option disables legacy support if no USB devices are connected.

DISABLE option will keep USB devices available only for EFI applications.

USB3.0 Support

Enable/Disable USB3.0 (XHCI) Controller support.

XHCI Hand-off

This is a workaround for OSes without XHCI hand-off support. The XHCI ownership change should be claimed by XHCI driver.

EHCI Hand-off

This is a workaround for OSes without EHCI hand-off support. The XHCI ownership change should be claimed by EHCI driver.

USB Mass Storage Driver Support

Enable/Disable USB Mass Storage Driver Support.

USB Transfer time-out

The time-out value for Control, Bulk, and Interrupt transfers.

Device reset time-out

USB mass Storage device start Unit command time-out.

Device power-up delay

Maximum time the device will take before it properly reports itself to the Host Controller.

'Auto' uses default value: for a Root port it is 100ms, for a Hub port the delay is taken from Hub descriptor.

F81846 Super IO Configuration

Aptio Setup Utility - Copyright © 2012 American Megatrends, Inc.

Main	Advanced	Chipset	Boot	Security	Save & Exit
F81846 Super IO Configuration					
F81846 Super IO Chip			F81846	→ ←Select Screen ↑ ↓Select Item Enter: Select +- Change Opt. F1: General Help F2: Previous Values F3: Optimized Defaults F4: Save & Exit ESC: Exit	
▶ Serial Port 0 Configuration					
▶ Serial Port 1 Configuration					

Serial Port Configuration

Set Parameters of Serial Ports. User can Enable/Disable the serial port and Select an optimal settings for the Super IO Device.

F81846 H/W Monitor

Aptio Setup Utility - Copyright © 2012 American Megatrends, Inc.

Main	Advanced	Chipset	Boot	Security	Save & Exit
PC Health Status					
CPU temperature			+34 C		
SYS temperature			+29 C		
FAN1 Speed			2170 RPM		
FAN2 Speed			2170 RPM		
FAN3 Speed			2170 RPM		
+5V			+5.087 V		→ ←Select Screen
+12V			+12.056 V		↑ ↓Select Item
Fan 1 smart fan control			50 C		Enter: Select
Fan 1 smart fan control			50 C		+ - Change Opt.
Fan 1 smart fan control			50 C		F1: General Help
					F2: Previous Values
					F3: Optimized Defaults
					F4: Save & Exit
					ESC: Exit

Temperatures/Voltages

These fields are the parameters of the hardware monitoring function feature of the motherboard. The values are read-only values as monitored by the system and show the PC health status.

Smart SYS_FAN1/CPU_FAN1 Function

This field enables or disables the smart fan feature.

Disabled (default)

50 °C

60 °C

70 °C

80 °C

Chipset Settings

This section allows you to configure and improve your system and allows you to set up some system features according to your preference.

Aptio Setup Utility - Copyright © 2012 American Megatrends, Inc.

Main	Advanced	Chipset	Boot	Security	Save & Exit
<ul style="list-style-type: none"> ▶ PCH-IO Configuration ▶ System Agent (SA) Configuration 					

PCH-IO Configuration

This section allows you to configure the North Bridge Chipset.

Aptio Setup Utility - Copyright © 2012 American Megatrends, Inc.

Main	Advanced	Chipset	Boot	Security	Save & Exit
Intel PCH RC Version 1.8.0.0					
Intel PCH SKU Name		Q87			
Intel PCH Rev ID		05/C2			
<ul style="list-style-type: none"> ▶ PCI Express Configuration ▶ USB Configuration ▶ PCH Azalia Configuration 					
PCH LAN Controller		Enabled			
Wake on LAN		Enabled			
					→ ←Select Screen ↑ ↓Select Item Enter: Select +- Change Opt. F1: General Help F2: Previous Values F3: Optimized Defaults F4: Save & Exit ESC: Exit

PCH LAN Controller

Enable or disable onboard NIC.

Wake on LAN

Enable or disable integrated LAN to wake the system. (The Wake On LAN cannot be disabled if ME is on at Sx state.)

PCI Express Configuration

Aptio Setup Utility - Copyright © 2012 American Megatrends, Inc.

Main	Advanced	Chipset	Boot	Security	Save & Exit
PCI Express Configuration					
DMI Link ASPM Control			Enabled		
DMI Link Extended Synch Control			Disabled		
PCIe-USB Glitch W/A			Disabled		
Subtractive Decode			Disabled		
<ul style="list-style-type: none"> ▶ PCI Express Root Port 1 ▶ PCI Express Root Port 2 ▶ PCI Express Root Port 3 ▶ PCI Express Root Port 4 ▶ PCI Express Root Port 5 <li style="padding-left: 20px;">PCI-E Port 6 is assigned to LAN ▶ PCI Express Root Port 7 ▶ PCI Express Root Port 8 					
→ ←Select Screen ↑ ↓Select Item Enter: Select +- Change Opt. F1: General Help F2: Previous Values F3: Optimized Defaults F4: Save & Exit ESC: Exit					

DMI Link ASPM Control

The control of Active State Power Management on both NB side and SB side of the DMI Link.

DMI Link Extended Synch Control

The control of Extended Synch on SB side of the DMI Link.

PCIe-USB Glitch W/A

PCIe-USB Glitch W/A for bad USB device(s) connected behind PCIE/PEG port.

Subtractive Decode

Enable or disable PCI Express Subtractive Decode.

USB Configuration

Main	Advanced	Chipset	Boot	Security	Save & Exit
USB Configuration					→ ← Select Screen ↑ ↓ Select Item Enter: Select +- Change Opt. F1: General Help F2: Previous Values F3: Optimized Defaults F4: Save & Exit ESC: Exit
USB Precondition			Disabled		
xHCI Mode			Auto		
USB Ports Per-Port Disable Control			Disabled		

USB Precondition

Precondition work on USB host controller and root ports for faster enumeration.

xHCI Mode

Mode of operation of xHCI controller.

USB Ports Per-Port Disable Control

Control each of the USB ports (0~13) disabling.

PCH Azalia Configuration

Aptio Setup Utility - Copyright © 2012 American Megatrends, Inc.

Main	Advanced	Chipset	Boot	Security	Save & Exit
PCH Azalia Configuration					
Azalia			Auto		

Azalia

Control Detection of the Azalia device.

Disabled = Azalia will be unconditionally disabled.

Enabled Azalia will be unconditionally Enabled.

Auto = Azalia will be enabled if present, disabled otherwise.

System Agent (SA) Configuration

Aptio Setup Utility - Copyright © 2012 American Megatrends, Inc.

Main	Advanced	Chipset	Boot	Security	Save & Exit
				Haswell	
			1.8.0.0		
			Supported		
			Enabled		→ ←Select Screen ↑ ↓Select Item Enter: Select +- Change Opt. F1: General Help F2: Previous Values F3: Optimized Defaults F4: Save & Exit ESC: Exit
▶	Graphics Configuration				
▶	Memory Configuration				

VT-d

Check to enable VT-d function on MCH.

Graphics Configuration

Aptio Setup Utility - Copyright © 2012 American Megatrends, Inc.

Main	Advanced	Chipset	Boot	Security	Save & Exit
					→ ←Select Screen ↑ ↓Select Item Enter: Select +- Change Opt. F1: General Help F2: Previous Values F3: Optimized Defaults F4: Save & Exit ESC: Exit
		PEG			
		Auto			
		Auto			
		Disabled			

Primary Display

Select which of IGFX/PEG/PCI graphics device should be Primary Display or select SG for switchable Gfx.

Primary PEG

Select PEG0/PEG1/PEG2/PEG3 Graphics device should be Primary PEG.

Primary PCIE

Select PCIE0/PCIE1/PCIE2/PCIE3/PCIE4/PCIE5/PCIE6/PCIE7 Graphics device should be Primary PCIE.

Internal Graphics

Keep IGD enabled based on the setup options.

Memory Configuration

Aptio Setup Utility

Main	Advanced	Chipset	Boot	Security	Save & Exit
Memory Information					
Memory RC Version			1.8.0.0		
Memory Frequency			1600 MHz		
Total Memory			32768MB (DDR3)		
Memory Voltage			1.50V		→ ←Select Screen
DIMM#0			8192 MB (DDR3)		↑ ↓Select Item
DIMM#1			8192 MB (DDR3)		Enter: Select
DIMM#2			8192 MB (DDR3)		+ - Change Opt.
DIMM#3			8192 MB (DDR3)		F1: General Help
					F2: Previous Values
					F3: Optimized Defaults
					F4: Save & Exit
					ESC: Exit

CSM parameters

This section allows you to configure the boot settings.

Aptio Setup Utility - Copyright © 2012 American Megatrends, Inc.

Main	Advanced	Chipset	Boot	Security	Save & Exit
Launch CSM			Enabled		
Boot option filter			UEFI and Legacy		
Launch PXE OpROM policy			Do not launch		→ ← Select Screen
Launch Storage OpROM policy			Legacy only		↑ ↓ Select Item
Launch Video OpROM policy			Legacy only		Enter: Select
Other PCI device ROM priority			Legacy OpROM		+ - Change Opt.
					F1: General Help
					F2: Previous Values
					F3: Optimized Defaults
					F4: Save & Exit
					ESC: Exit

Launch CSM

This option controls if CSM will be launched

Boot option filter

This option controls what devices system can boot to

Launch PXE OpROM policy

Controls the execution of UEFI and Legacy PXE OpROM

Launch Storage OpROM policy

Controls the execution of UEFI and Legacy Storage OpROM

Launch Video OpROM policy

Controls the execution of UEFI and Legacy Video OpROM

Other PCI device ROM priority

For PCI devices other than Network, Mass storage or Video defines which OpROM to launch

Security Settings

This section allows you to configure and improve your system and allows you to set up some system features according to your preference.

Aptio Setup Utility - Copyright © 2012 American Megatrends, Inc.

Main	Advanced	Chipset	Boot	Security	Save & Exit
Password Description If ONLY the Administrator's password is set, then this only limit access to Setup and is only asked for when entering Setup. If ONLY the User's password is set, then this is a power on password and must be entered to boot or enter Setup. In Setup the User will have Administrator rights. The password length must be in the following range:					
Minimum length			3		→ ←Select Screen ↑ ↓Select Item Enter: Select +- Change Opt. F1:General Help F2:Previous Values F3: Optimized Defaults F4: Save & Exit ESC: Exit
Maximum length			20		
Administrator Password					
User Password					

Administrator Password

Set Administrator Password

User Password

Set User Password

Save & Exit Settings

Aptio Setup Utility - Copyright © 2012 American Megatrends, Inc.

Main	Advanced	Chipset	Boot	Security	Save & Exit
Save Changes and Exit					
Discard Changes and Exit					
Save Changes and Reset					
Discard Changes and Reset					
Save Options					→ ←Select Screen
Save Changes					↑ ↓ Select Item
Discard Changes					Enter: Select
Restore Defaults					+ - Change Opt.
Save as User Defaults					F1:General Help
Restore User Defaults					F2:Previous Values
					F3: Optimized Defaults
					F4: Save & Exit
					ESC: Exit

Save Changes and Exit

Exit system setup after saving the changes.

Discard Changes and Exit

Exit system setup without saving any changes.

Save Changes and Reset

Reset the system after saving the changes.

Discard Changes and Reset

Reset system setup without saving any changes.

Save Changes

Save Changes done so far to any of the setup options.

Discard Changes

Discard Changes done so far to any of the setup options.

Restore Defaults

Restore/Load Defaults values for all the setup options.

Save as User Defaults

Save the changes done so far as User Defaults.

Restore User Defaults

Restore the User Defaults to all the setup options.

CHAPTER 4 DRIVERS INSTALLATION

The Intel Chipset Drivers should be installed first before the software drivers to enable Plug & Play INF support for Intel chipset components. Follow the instructions below to complete the installation.

IMPORTANT NOTE:

After installing your Windows operating system, you must install first the Intel Chipset Software Installation Utility before proceeding with the drivers installation.

4.1 Intel Chipset Software Installation Utility

1. Insert the DVD that comes with the board. Click **System** and then **SI-60E Series Products**.



- . Click **Intel(R) Chipset Software Installation Utility**.



3. When the Welcome screen to the Intel® Chipset Device Software appears, click **Next** to continue.



4. Click **Accept** to accept the software license agreement and proceed with the installation process.



5. On the Readme File Information screen, click **Install** to continue the installation.

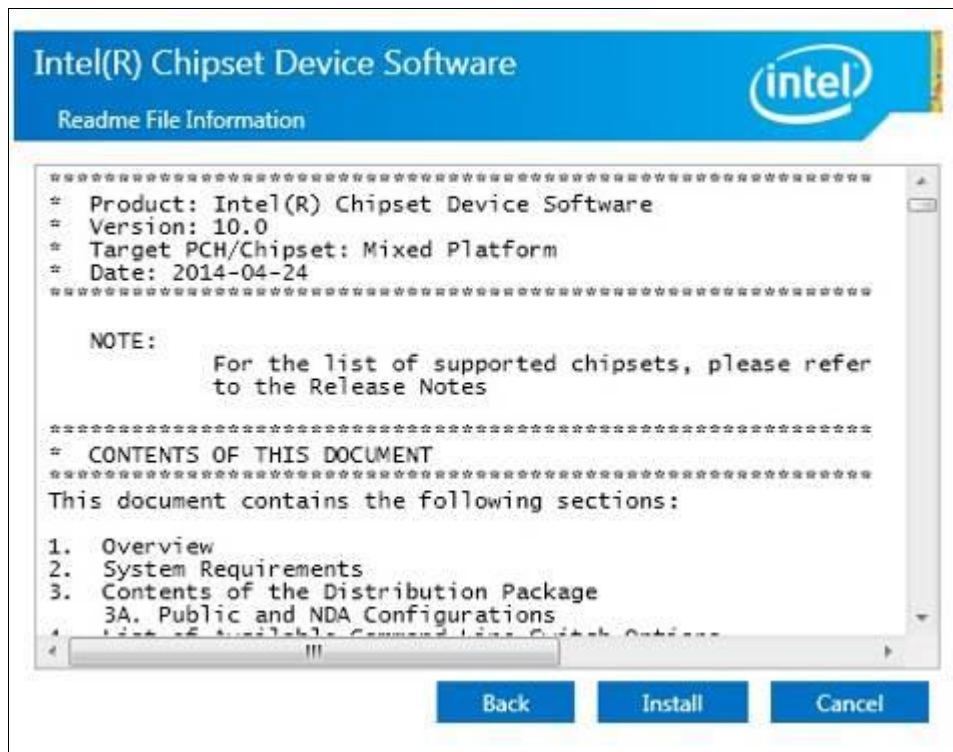

6. The Setup process is now complete. Click **Finish** to restart the computer and for changes to take effect.



4.2 AMD Radeon E8860 Graphics Driver

1. Insert the DVD that comes with the board. Click **System** and then **SI-60E Series Products**. Click **AMD Radeon E8860 Graphics Driver**.



2. When the Welcome screen appears, click **Next** to continue.

3. Select the language you would like to be displayed and click **Next**.



4. Click **Install** to continue the installation process.



5. Select Express and the installation location and click Next.



6. Click **Accept** to accept the End User License Agreement.



7. Setup complete. Click **Finish** to restart the computer and for changes to take effect.



8. To reboot the system, click **Yes**.

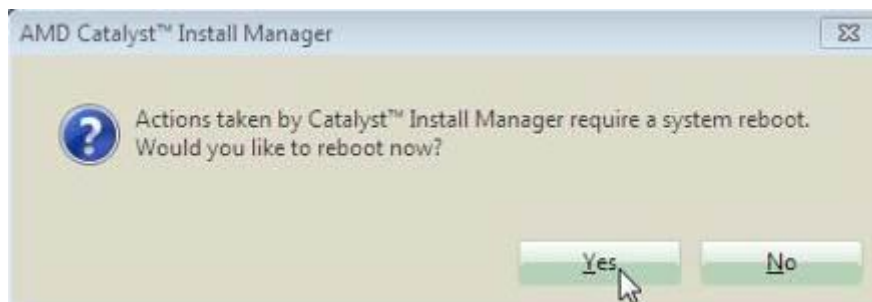

4.3 Realtek High Definition Audio Driver

1. Insert the DVD that comes with the board. Click **System** and then **SI-60E Series Products**.

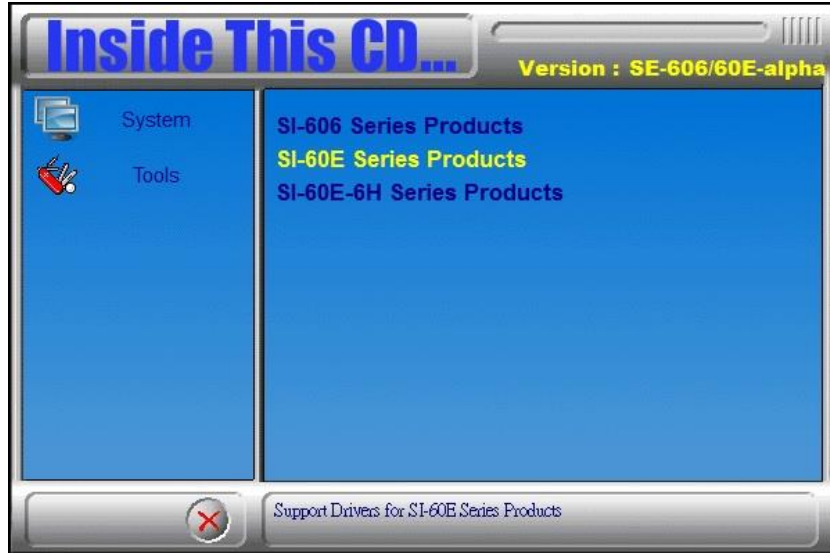

2. Click **Realtek High Definition Audio Driver**.



3. On the Welcome to the InstallShield Wizard screen, click **Yes** to proceed with and complete the installation process.



4. The InstallShield Wizard Complete. Click **Finish** to restart the computer and for changes to take effect.



4.4 Intel® I21x Gigabit Network Driver

1. Insert the DVD that comes with the board. Click **System** and then **SI-60E Series Products**.

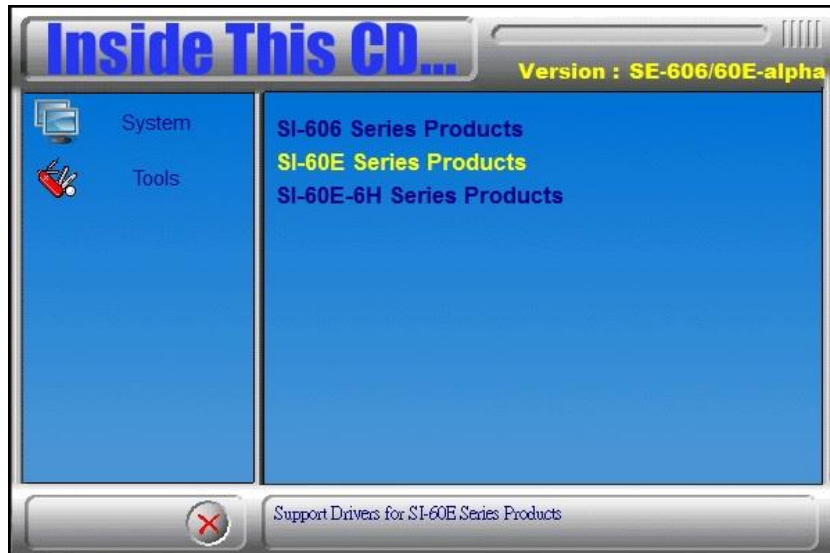

2. Click **Intel® I21x Gigabit Network Driver**.



3. When the Welcome screen appears, click **Next**.



4. Click **Next** to to agree with the license agreement.



5. Click the checkbox for **Drivers** in the Setup Options screen to select it and click **Next** to continue.

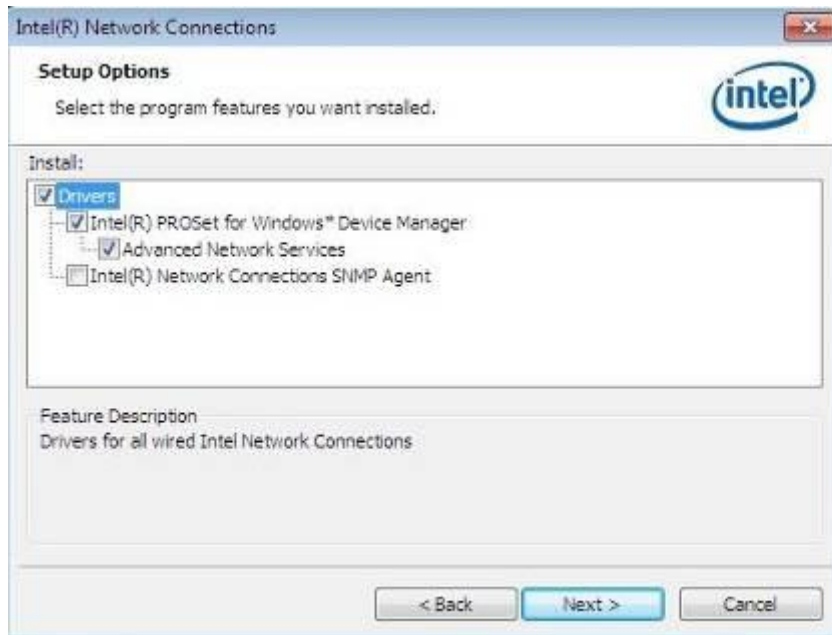

6. The wizard is ready to begin installation. Click **Install** to begin the installation.

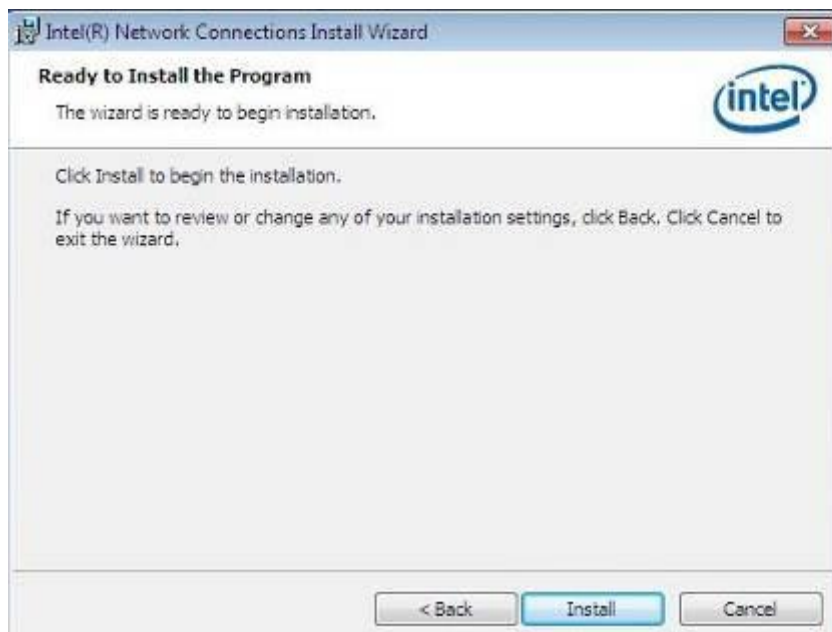

7. When InstallShield Wizard is complete, click **Finish**.

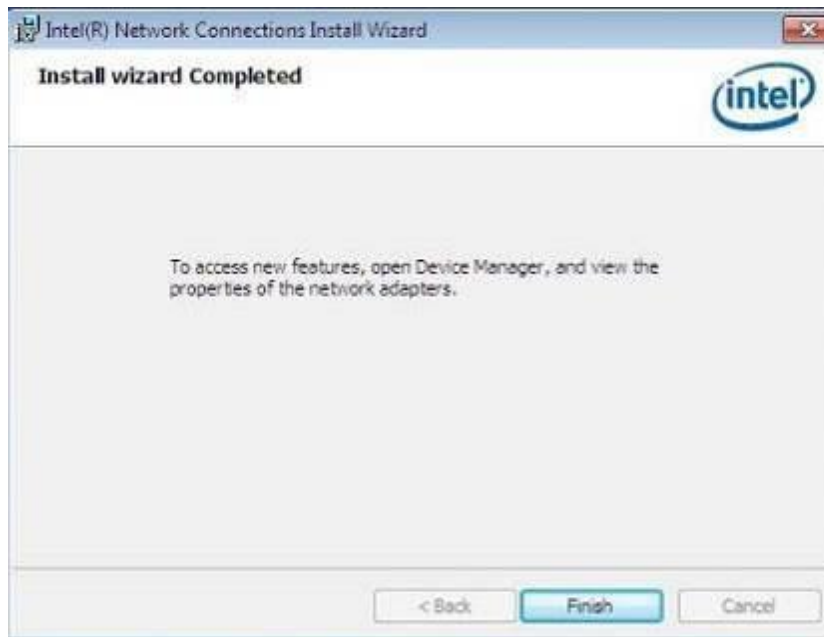

4.5 Intel® Management Engine(ME) Driver

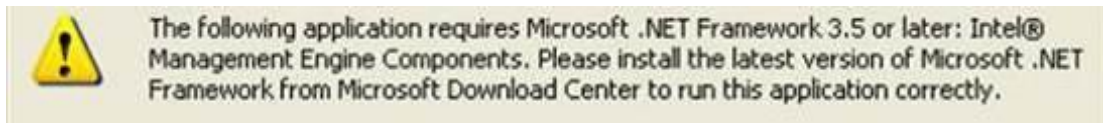

Follow the steps below to install the Intel Management Engine.

1. Insert the DVD that comes with the board. Click **System** and then **SI-60E Series Products** and then **Intel® Management Engine(ME) Driver**.



2. When the Welcome screen for Intel® Management Engine Components, click the checkbox for **Install Intel® Control Center** & click **Next**.

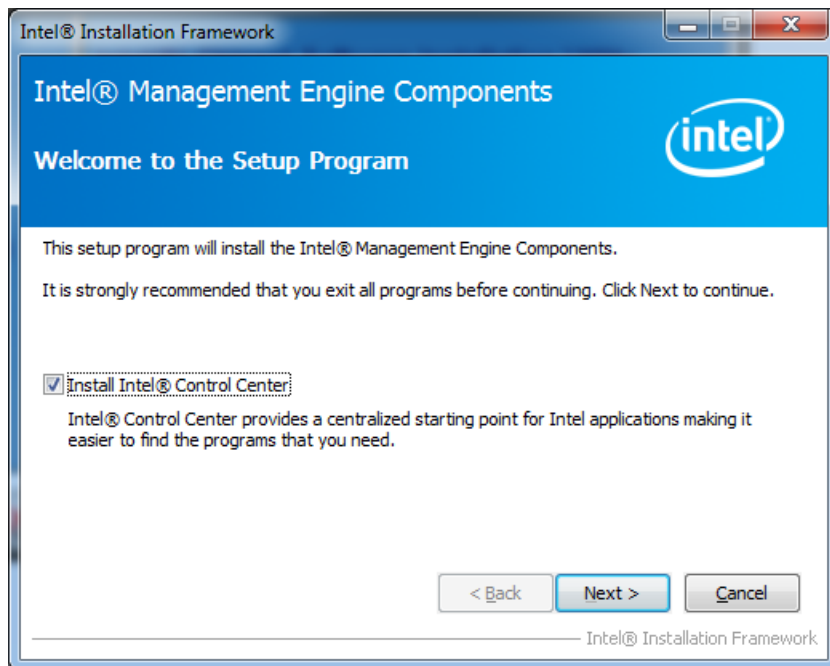

3. Click **Yes** to agree with the license agreement.

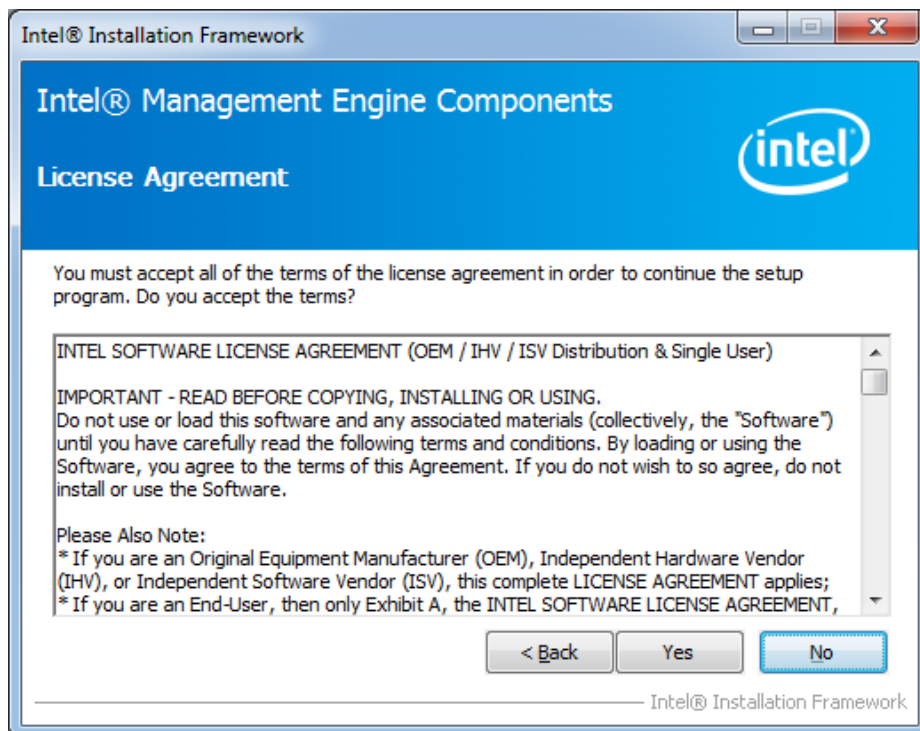

4. When the Setup Progress screen appears, click **Next**. Then, click **Finish** when the setup progress has been successfully installed.

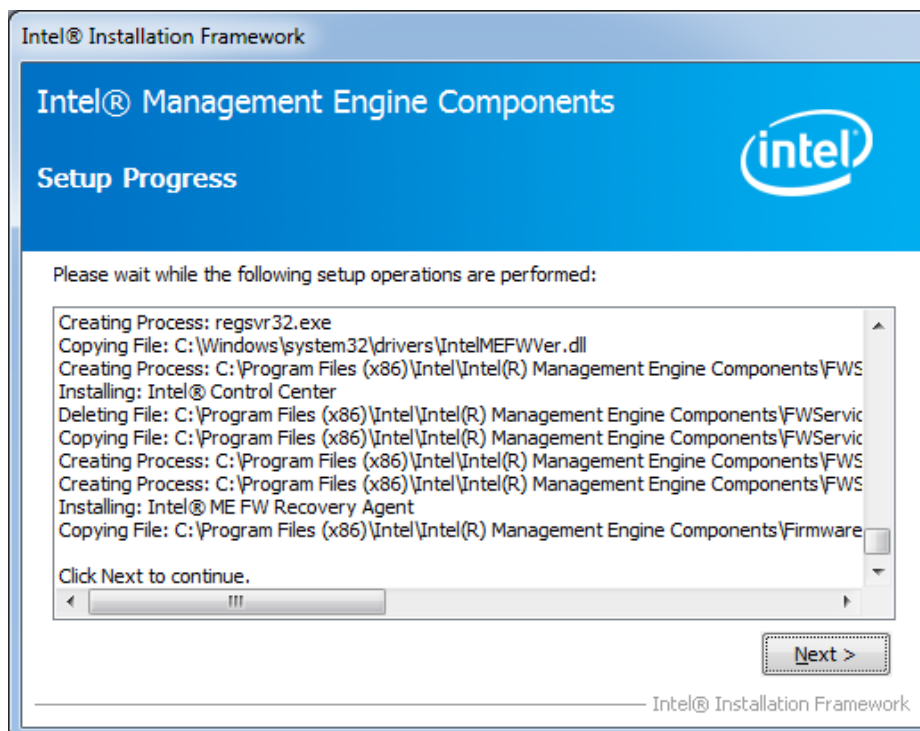



4.6 Intel® USB 3.0 eXtensible Host Controller Driver

1. Insert the DVD that comes with the board. Click **System** and then **SI-60E Series Products**. Click **Intel® USB 3.0 eXtensible Host Controller Driver**.



2. When the Welcome screen to the InstallShield Wizard for Intel® USB 3.0 eXtensible Host Controller Driver, click **Next**.



3. Click **Yes** to to agree with the license agreement and continue the installation.



4. On the Readme File Information screen, click **Next** to continue the installation of the Intel® USB 3.0 eXtensible Host Controller Driver.



5. Setup complete. Click **Finish** to restart the computer and for changes to take effect.



4.7 Realtek RTL8111G LAN Driver

1. Insert the DVD that comes with the board. Click **System** and then **SI-60E Series Products**. Click **Realtek RTL8111G LAN Driver**.



2. In the Welcome screen, click **Next**.

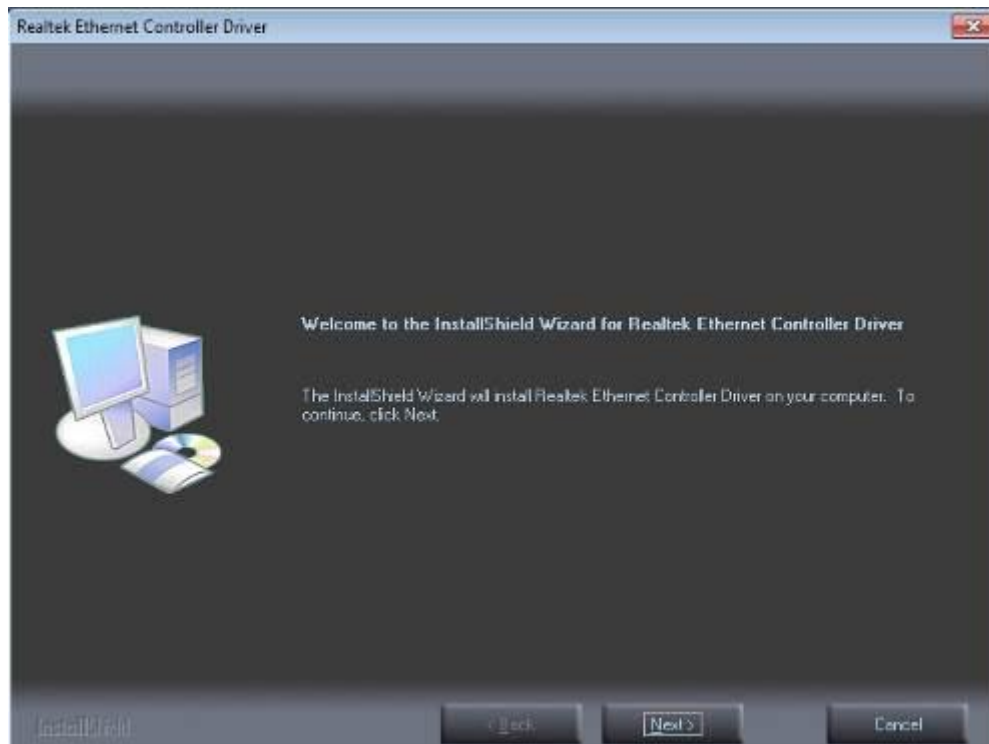

3. When the Ready to Install the Program screen appears, click **Install** to continue.

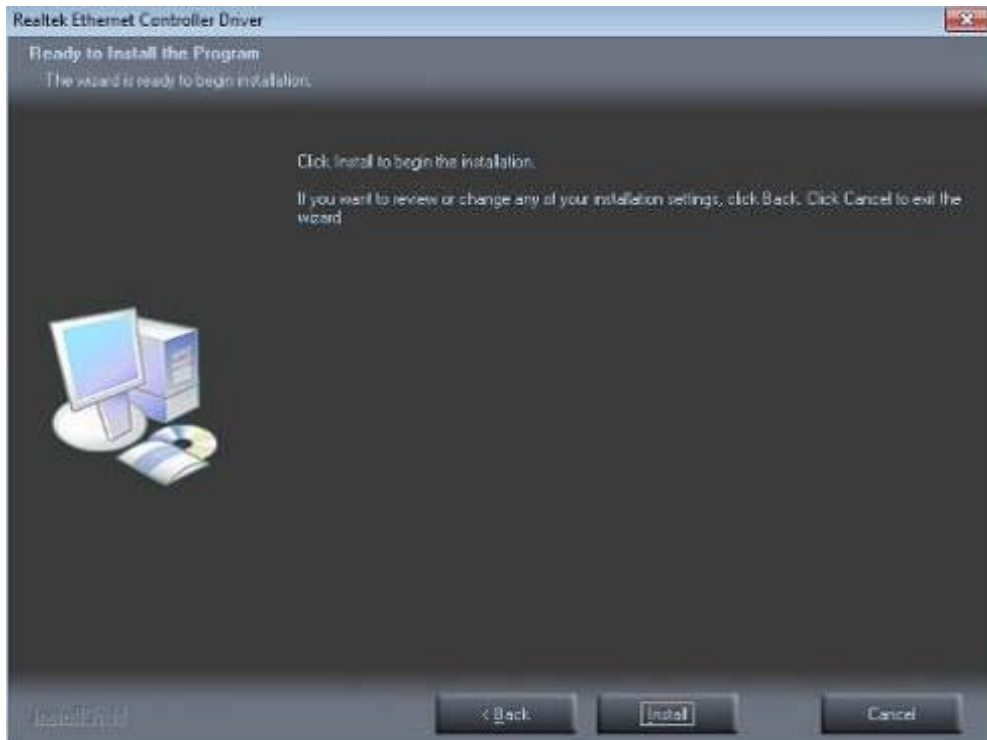

4. When InstallShield Wizard is complete, click **Finish**.

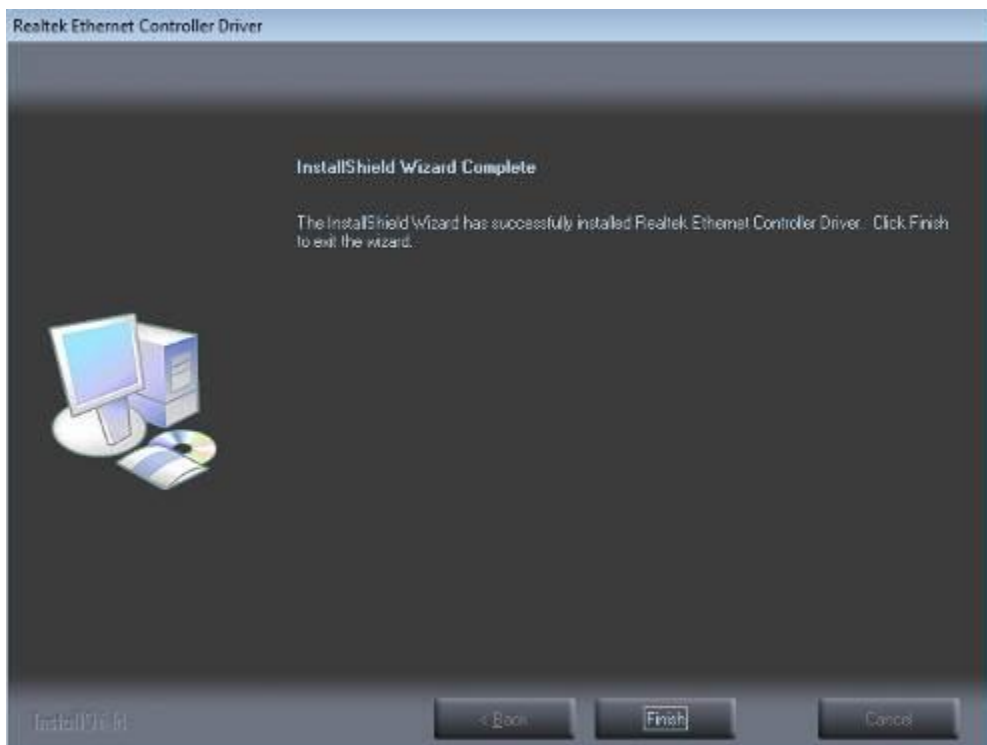

4.8 IDD100 Driver and Utility

1. Insert the DVD that comes with the board. Click **System** and then **SI-60E Series Products**. Click **IDD100 Driver and Utility**.



2. Click **CP210x Installer**



3. In the Welcome screen, click **Next**.



4. When the License Agreement the Program screen appears, click **I accept this agreement and Next**.



5. When complete the Installation of the CP210x USB to UART Bridge Driver, click **Finish**.



6. Click **SI-60E Installer**.



7. In the Welcome screen, click **Next**.



8. When the Destination Folder screen appears, click **Next**.



9. When the Ready to Install the Program screen appears, click **Install**.

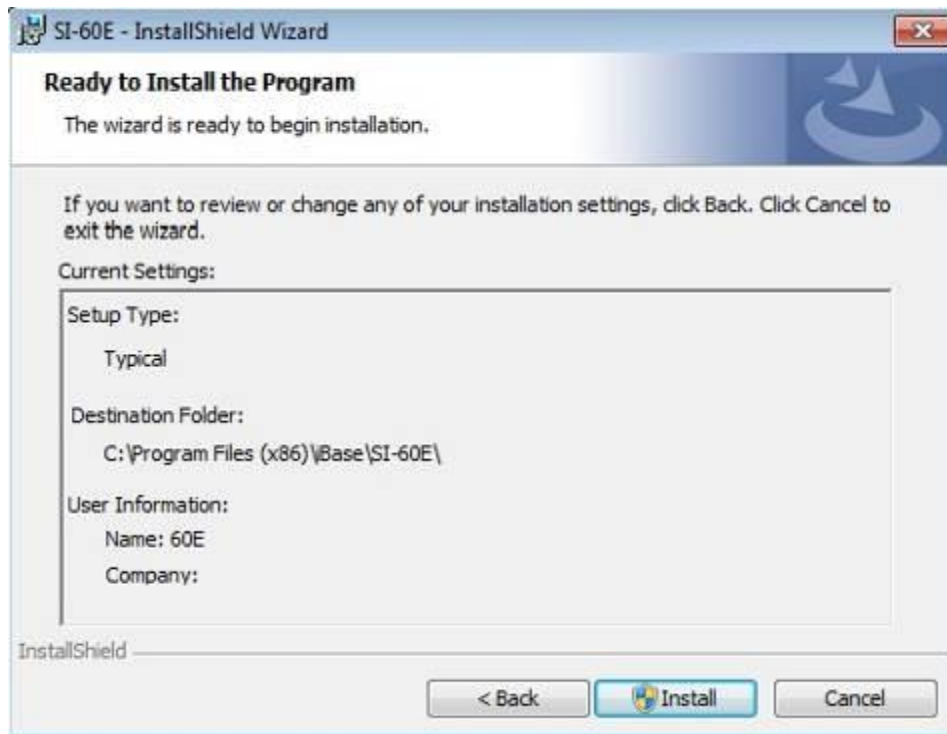

10. When InstallShield Wizard Complete, click Finish.

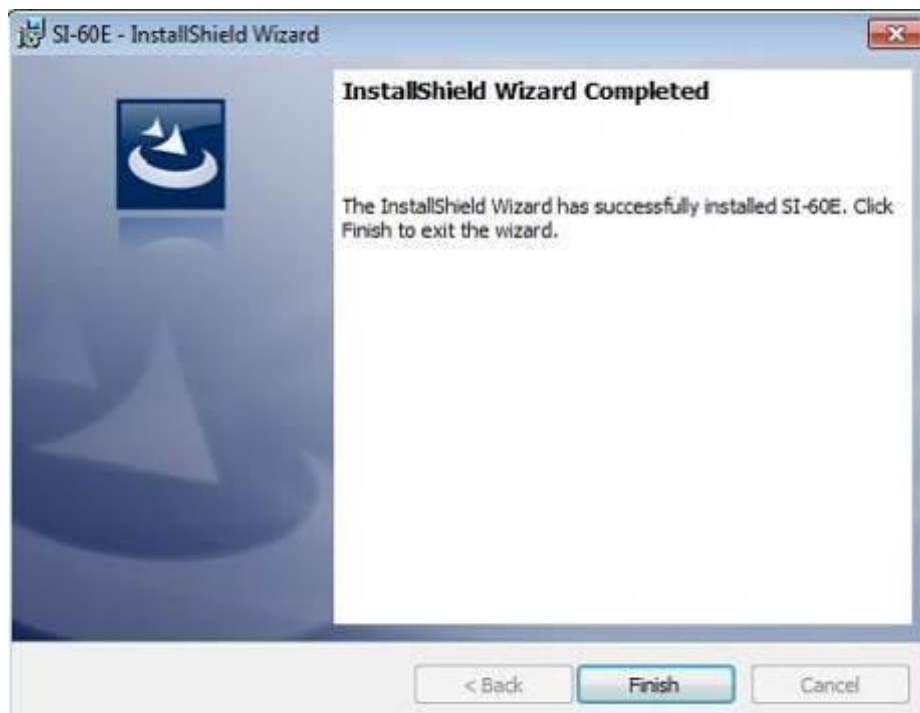

Appendix

A. IBASE Display Matrix User Manual

Software UART Control Application interface

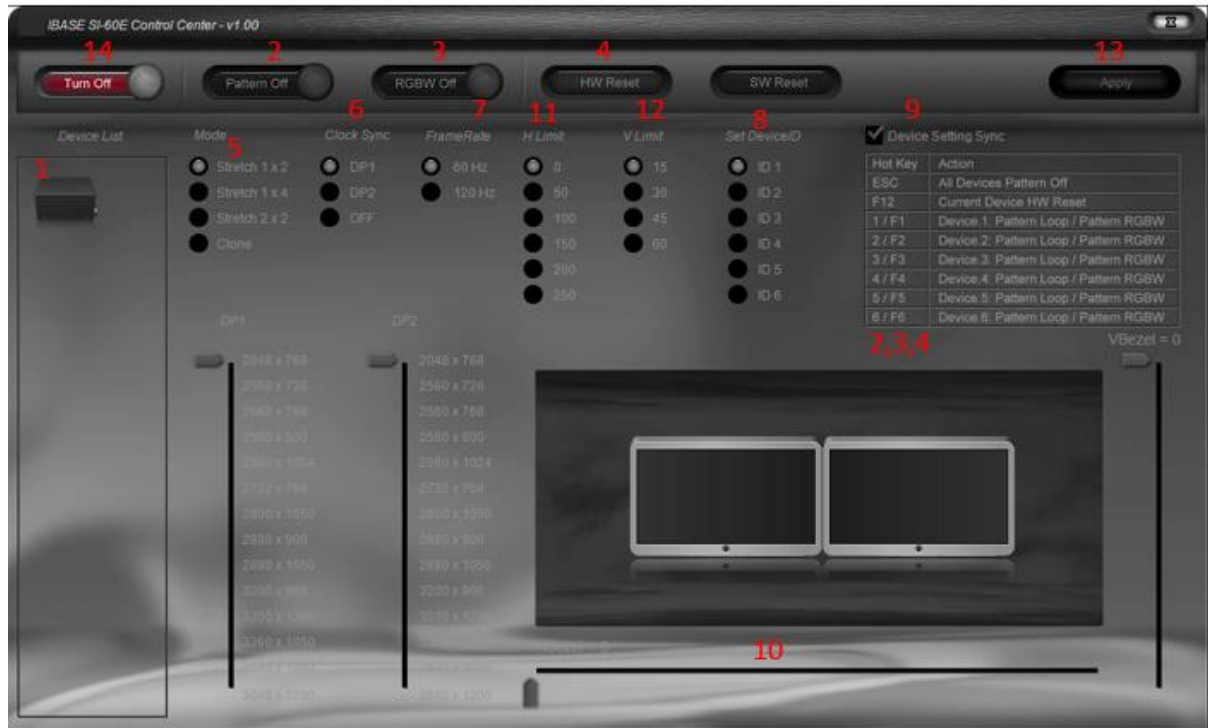

Function Description

1. Device List: Max support up to 6 Box
2. Auto Loop Pattern (Button/Hot Key)
3. RGBW Pattern (Button/Hot Key)
4. HW RESET (Button/Hot Key)
5. MODE Clone/1x2/1x4/2x2
6. Support CLK SYNC
7. Support 60Hz/120Hz Modes
8. Support Multi-Box ID
9. Support Multi-Box Device Setting
10. Support H and V Bezel Adjustment
11. H Blanking Setting
12. V Blanking Setting
13. Apply Key
14. Program On/Off

Display Mode Table

Stretch (1x2)	Stretch (1x4)	Stretch (2x2)	Clone
3840x1200	7680x1200	3840x2400	1920x1200
3840x1080	7680x1080	3840x2160	1920x1080
3360x1050	6720x1050	3360x2100	1680x1050
3200x1200	6400x1200	3200x2400	1600x1200
3200x0900	6400x0900	3200x1800	1600x0900
2880x1050	5760x1050	2880x2160	1440x1050
2880x0900	5760x0900	2880x1800	1440x0900
2800x1050	5600x1050	2800x2100	1400x1050
2732x0768	5464x0768	2732x1536	1366x0768
2560x1024	5120x1024	2560x2048	1280x1024
2560x0800	5120x0800	2560x1600	1280x0800
2560x0768	5120x0768	2560x1536	1280x0768
2560x0720	5120x0720	2560x1440	1280x0720
2048x0768	4096x0768	2048x1536	1024x0768

Bezel Limit with Blanking Parameter Table

H Limit	V Limit
50	15
100	30
150	45
200	60
250	TBD

How to Set Clone Display

- Step 1: Enter to Display Control Page
- Step 2: Go to Mode Status Press Enter
- Step 3: Press Up / Down Key Select to Clone
- Step 4: Go to UP PORT to select a Display Mode
- Step 5: Go to Display Driver Control Page
- Step 6: Setting the two Monitor to Duplicate Mode

How to Setting 1x4 Display

- Step 1: Enter to Display Control Page
- Step 2: Go to Mode Status Press Enter
- Step 3: Press Up / Down Key Select to Stretch
- Step 4: Go to Display Layout to Select 1x4
- Step 5: Go to UP or DOWN Port select a Display Resolution
- Step 6: Go to Display Driver Control Page**
- Step 7: Setting the two Monitor to H Combine Condition**
- Step 8: Adjustment H Bezel

How to Setting 2x2 Display

- Step 1: Enter to Display Control Page
- Step 2: Go to Mode Status Press Enter
- Step 3: Press Up / Down Key Select to Stretch
- Step 4: Go to Display Layout to Select 2x2
- Step 5: Go to UP or DOWN Port select a Display Resolution
- Step 6: Go to Display Driver Control Page**
- Step 7: Setting the two Monitor to V Combine Condition**
- Step 8: Adjustment H Bezel Value
- Step 9: Adjustment V Bezel Value

B. IBASE Multiple-Display Matrix Technology Utility for 4 x 3 Video Wall

Display configuration setting

1.1 What is ATI Eyefinity Technology?

ATI Eyefinity Technology from AMD provides advanced multiple monitor technology delivering an incredibly immersive graphic and computing experience with innovative display capabilities, supporting massive desktop workspaces and super-high resolution signage applications. ATI Eyefinity technology with SI-60E 12 X HDMI connectivity enables a single GPU to support up to 12 display outputs simultaneously. For the purposes of this document an “ATI Eyefinity system” means a computer system employing ATI Eyefinity technology and an “ATI Eyefinity resolution” means a resolution achievable using ATI Eyefinity technology.

1.2 Product Description

IBASE offers user-friendly and powerful video solution in the form of SI-60E (Signature Book) with IBASE Multiple-Display Matrix Technology Utility & AMD Eyefinity function. Each IBASE SI-60E (Signature Book) with IBASE Multiple-Display Matrix Technology Utility & Eyefinity function can drive up to 12 displays with different display configuration.

SI-60E	Version
BIOS	MBD60E-D1B-D1A-150317
Utility	SI-60E V 1.0
VGA driver	14.301.1001-140915a-177267C-AES

1.3 SI-60E HDMI output and Display distribution

Before you would like to set up the VW display configuration, please plug display HDMI cable with SI-60E as following photo.



1.4 Driver Installation

Before using SI-60E (Signature Book)'s IBASE Multiple-Display Matrix Technology Utility & AMD Eyefinity function, the user must install both SI-60E Installer V 1.0 for (CP210xVCPIInstaller/ SI-60E ControlCenter) and AMD VGA driver completely.

1.4.1 IBASE Multiple-Display Matrix Technology Utility



Click SI-60E Icon on the Desktop, to have Software UART Control Application interface as shown:



“Turn on” Device List

IBASE SI-60E Control Center - v1.00

Turn On Pattern Off RGBW Off HW Reset SW Reset Apply

Device List	Mode	Clock Sync	FrameRate	H Limit	V Limit	Set DeviceID	Device Setting Sync																		
FW: 30 COM: 4 ID010 / ID: 3	<input type="radio"/> Stretch 1 x 2 <input checked="" type="radio"/> Stretch 1 x 4 <input type="radio"/> Stretch 2 x 2 <input type="radio"/> Clone	<input checked="" type="radio"/> DP1 <input type="radio"/> DP2 <input type="radio"/> OFF	<input checked="" type="radio"/> 60 Hz <input type="radio"/> 120 Hz	<input type="radio"/> 0 <input type="radio"/> 50 <input checked="" type="radio"/> 100 <input type="radio"/> 150 <input type="radio"/> 200 <input type="radio"/> 250	<input type="radio"/> 15 <input checked="" type="radio"/> 30 <input type="radio"/> 45 <input type="radio"/> 60	<input checked="" type="radio"/> ID 1 <input type="radio"/> ID 2 <input type="radio"/> ID 3 <input type="radio"/> ID 4 <input type="radio"/> ID 5 <input type="radio"/> ID 6	<table border="1"> <thead> <tr> <th>Hot Key</th> <th>Action</th> </tr> </thead> <tbody> <tr> <td>ESC</td> <td>All Devices Pattern Off</td> </tr> <tr> <td>F12</td> <td>Current Device HW Reset</td> </tr> <tr> <td>1 / F1</td> <td>Device 1: Pattern Loop / Pattern RGBW</td> </tr> <tr> <td>2 / F2</td> <td>Device 2: Pattern Loop / Pattern RGBW</td> </tr> <tr> <td>3 / F3</td> <td>Device 3: Pattern Loop / Pattern RGBW</td> </tr> <tr> <td>4 / F4</td> <td>Device 4: Pattern Loop / Pattern RGBW</td> </tr> <tr> <td>5 / F5</td> <td>Device 5: Pattern Loop / Pattern RGBW</td> </tr> <tr> <td>6 / F6</td> <td>Device 6: Pattern Loop / Pattern RGBW</td> </tr> </tbody> </table>	Hot Key	Action	ESC	All Devices Pattern Off	F12	Current Device HW Reset	1 / F1	Device 1: Pattern Loop / Pattern RGBW	2 / F2	Device 2: Pattern Loop / Pattern RGBW	3 / F3	Device 3: Pattern Loop / Pattern RGBW	4 / F4	Device 4: Pattern Loop / Pattern RGBW	5 / F5	Device 5: Pattern Loop / Pattern RGBW	6 / F6	Device 6: Pattern Loop / Pattern RGBW
Hot Key	Action																								
ESC	All Devices Pattern Off																								
F12	Current Device HW Reset																								
1 / F1	Device 1: Pattern Loop / Pattern RGBW																								
2 / F2	Device 2: Pattern Loop / Pattern RGBW																								
3 / F3	Device 3: Pattern Loop / Pattern RGBW																								
4 / F4	Device 4: Pattern Loop / Pattern RGBW																								
5 / F5	Device 5: Pattern Loop / Pattern RGBW																								
6 / F6	Device 6: Pattern Loop / Pattern RGBW																								

DP1: 4096 x 768, 5120 x 720, 5120 x 768, 5120 x 800, 5120 x 1024, 5464 x 768, 5600 x 1050, 5760 x 900, 5760 x 1050, 6400 x 900, 6400 x 1200, 6720 x 1050, 7680 x 1080, 7680 x 1200

DP2: 4096 x 768, 5120 x 720, 5120 x 768, 5120 x 800, 5120 x 1024, 5464 x 768, 5600 x 1050, 5760 x 900, 5760 x 1050, 6400 x 900, 6400 x 1200, 6720 x 1050, 7680 x 1080, 7680 x 1200

HBezel = 0 VBezel = 0

On the above Device List item, please confirm and check each IDD 100 Device with the different ID. If the Device has the same ID (the above two Device with the same ID 2), please **Disable** “Device Setting Sync” function, then select and click one of the same ID device, then select “Set DeviceID” function to change its ID number, and click “Apply” to finish the setting.

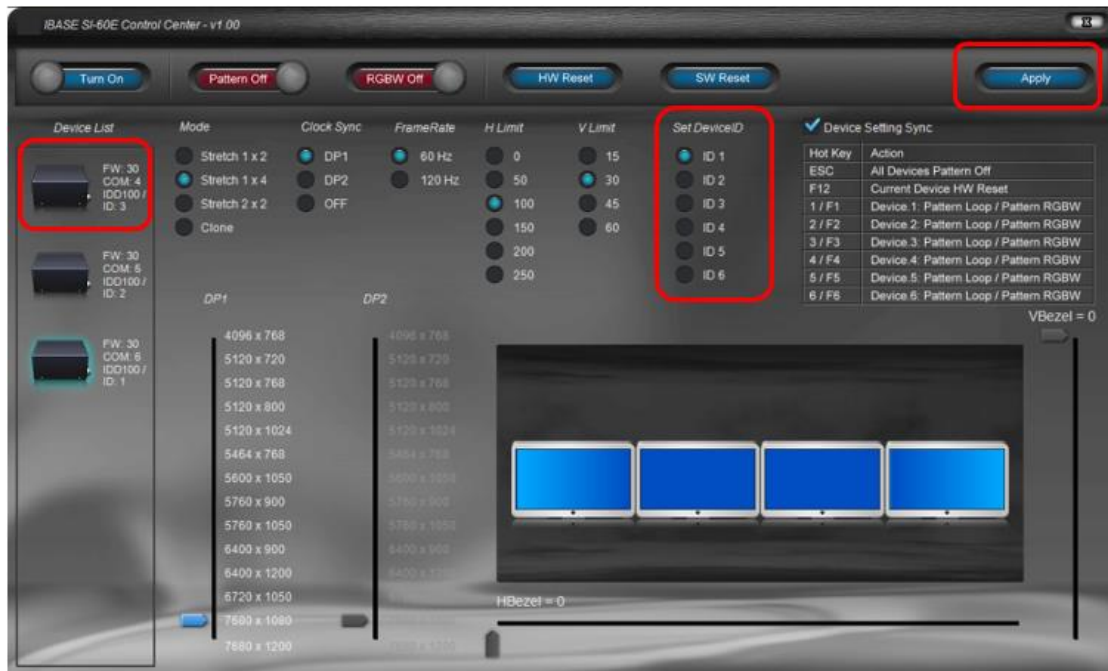

Each IDD100 Device supports 4x HDMI output, and maximum resolution of 1920 X 1200 per HDMI. You have to check the display resolution first, then choose the suitable resolution accordingly.

The following is an example for FHD displays. Choose “**Mode**” as Stretch **1x4** (IDD100 Device with 4 x HDMI output as **1 x 4** combination mode).

Please choose “**Clock Sync**” as DP1 and enable “**Device Setting Sync**”, then click “**Apply**”.

3 x IDD100 Device (Each with 4 x HDMI) will have the same setting at the same time.

It is necessary to make DP1 & DP2/DP3 & DP4 / DP5 & DP6 as Stretch **1x4** for 4x3 or 3x3 VW display configuration setting, especially if you want to have the bezel adjustment function.

Remarks: Setting **Clock Sync** as DP1 or DP2 can avoid the tearing issue, but you will not be able to use H&V Bezel adjustment. That means if you would like to have H & V Bezel adjustment, then it is necessary to disable DP1 or 2 Clock Sync as “OFF”.

The following picture shows how to disable Clock Sync:

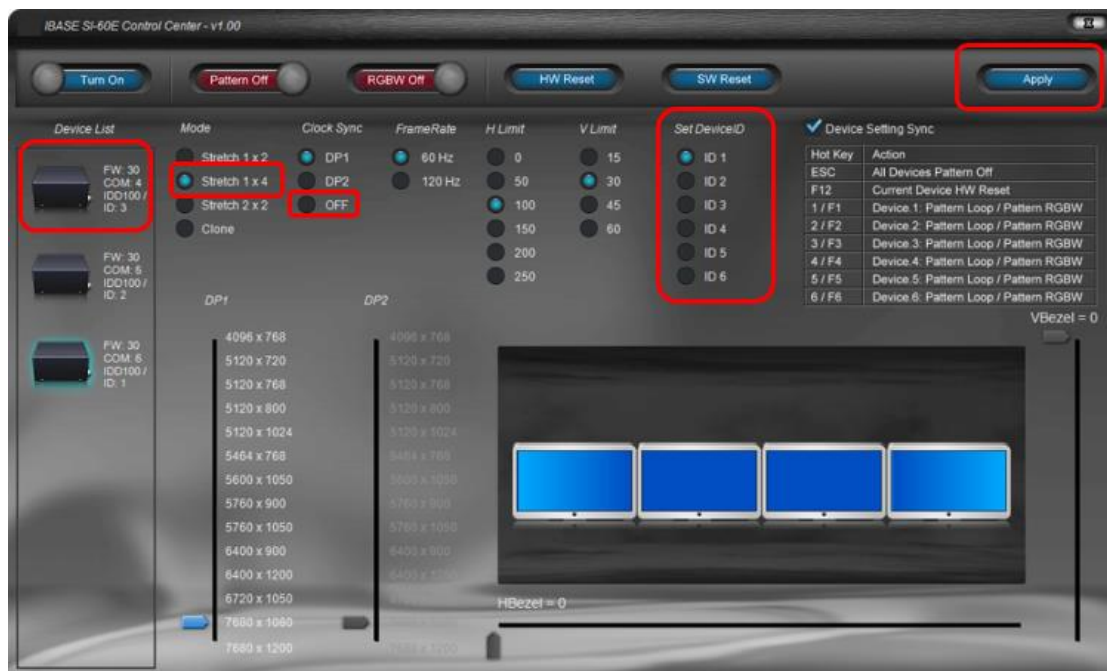

Now you can leave IBASE SI-60E control center V1.0 utility, and start using “**AMD Catalyst Control Center**”

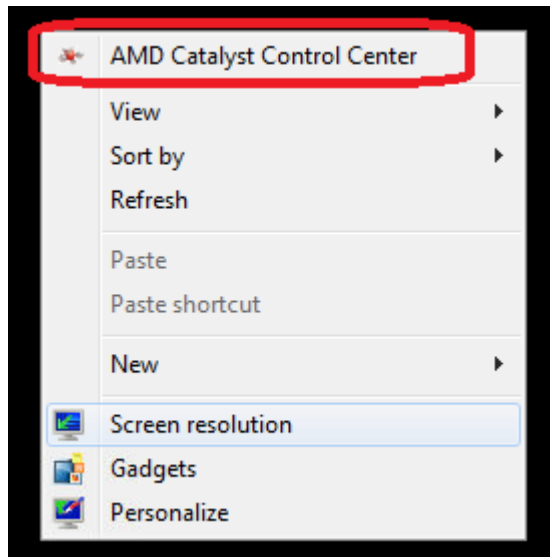

Choose “AMD Eyefinity Multi-Display” for Video wall display configuration setting.



Select **“Create Eyefinity Display Group”**

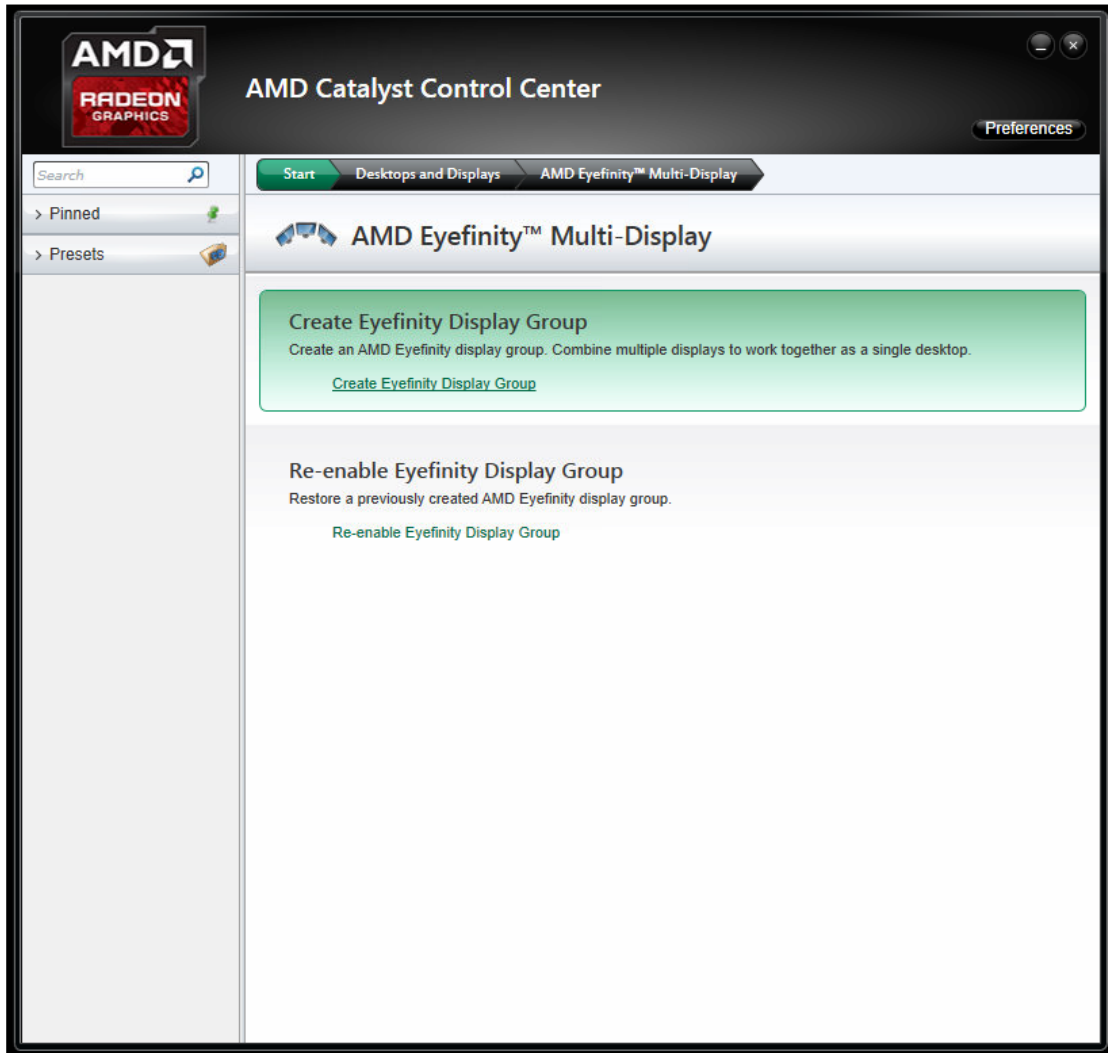

Select "2 x 3" for 4 x 3 Display configuration

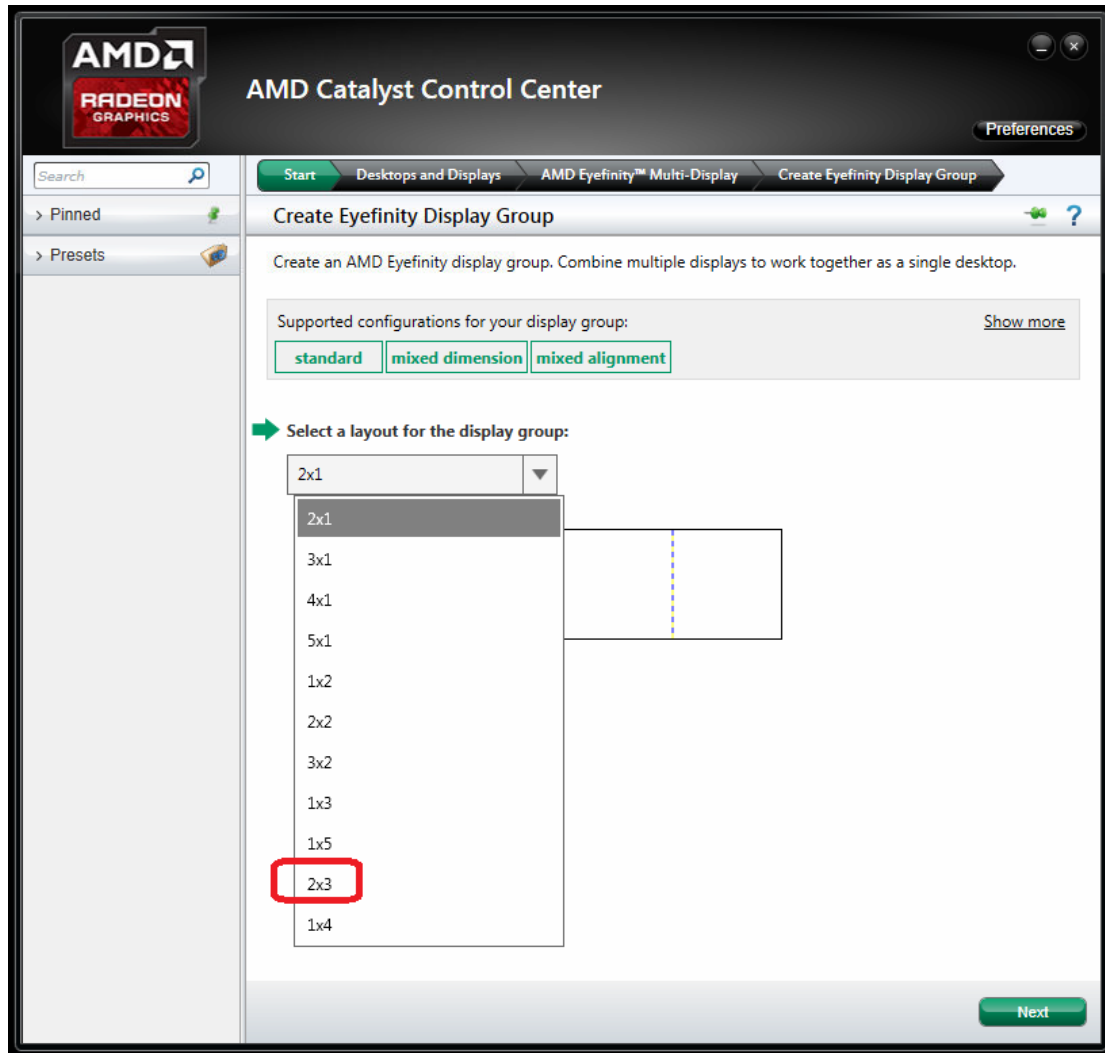

Make the displays arrangement

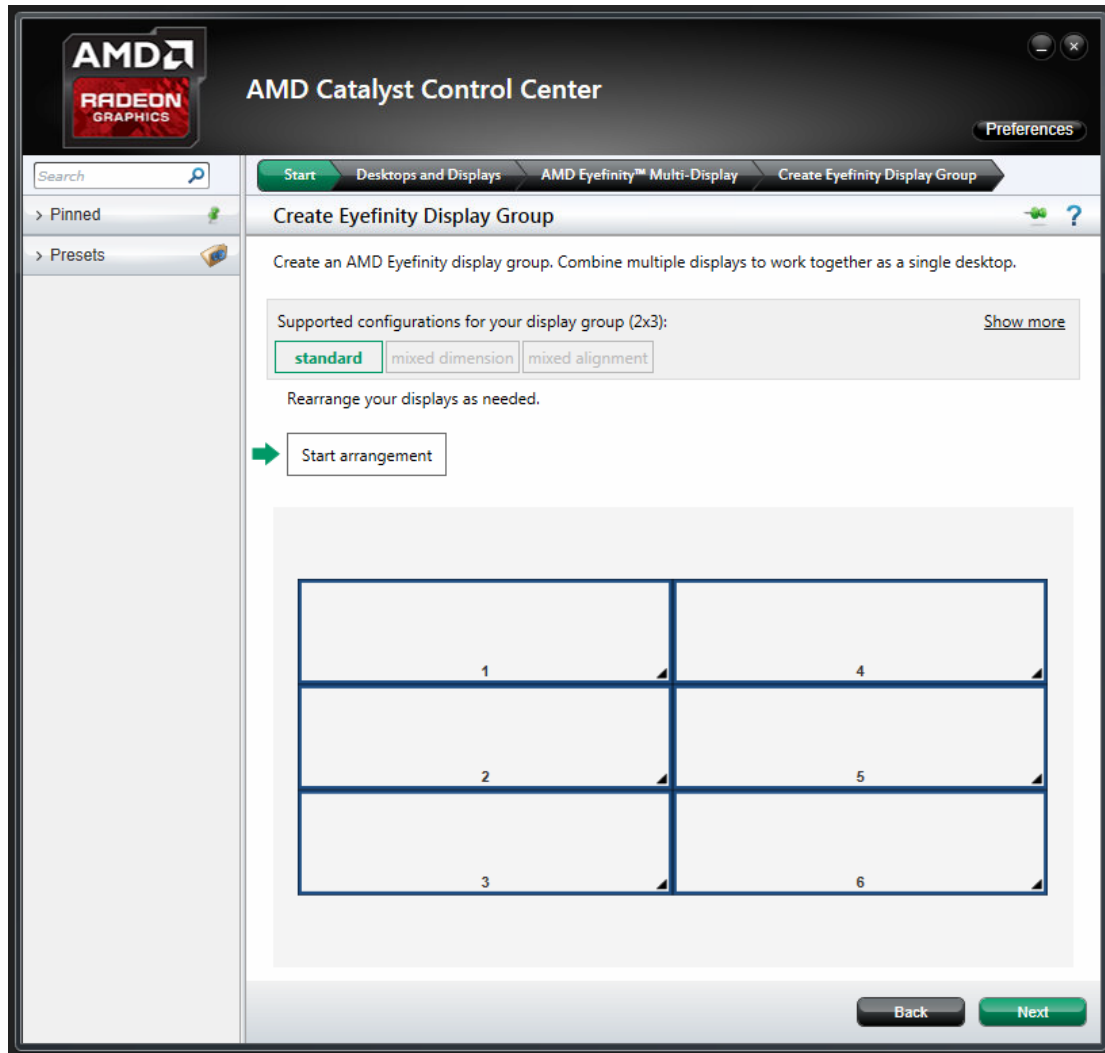

Complete the settings.

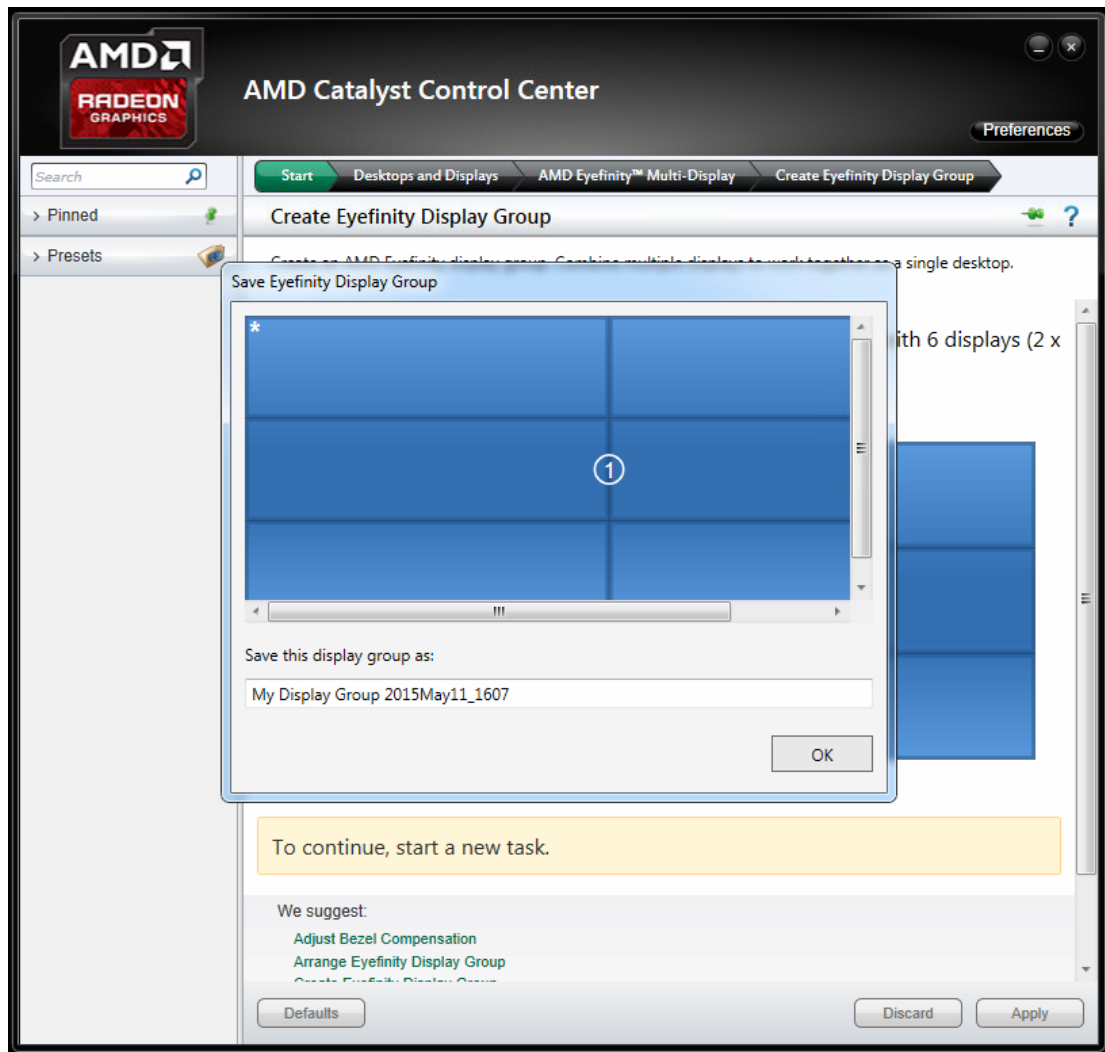

Now, you can use Screen resolution to check your setting.

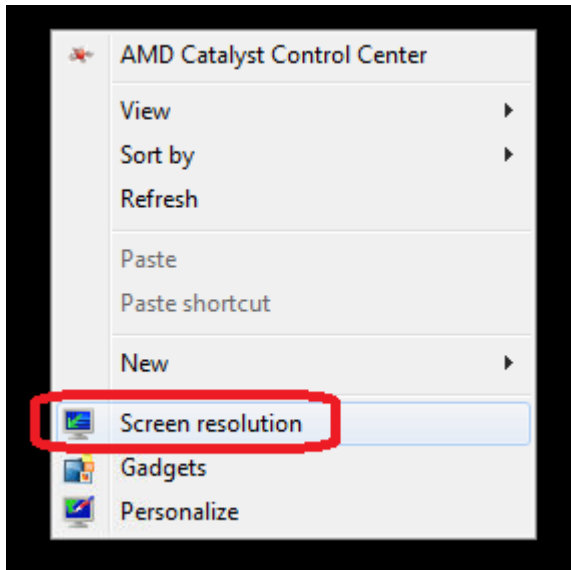

A screen with 7680 X 3240 is the correct setting for 4 x 3 Display configuration with FHD (1920 X 1080) resolution supported displays.

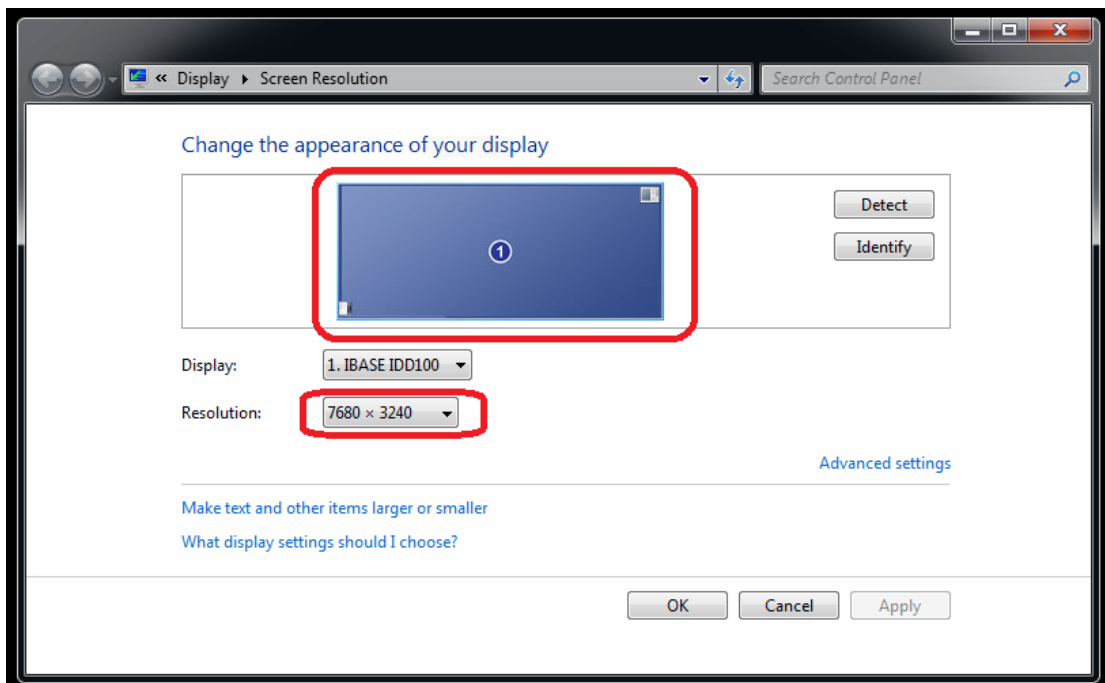

1.4.2 8 and 12 display configuration setting

A. 8 x 1 Display configuration

(1) Select “1 x 4 Stretch” by control center utility



(2) Create Eyefinity Display Group p"4 x 1" with AMD Eyefinity

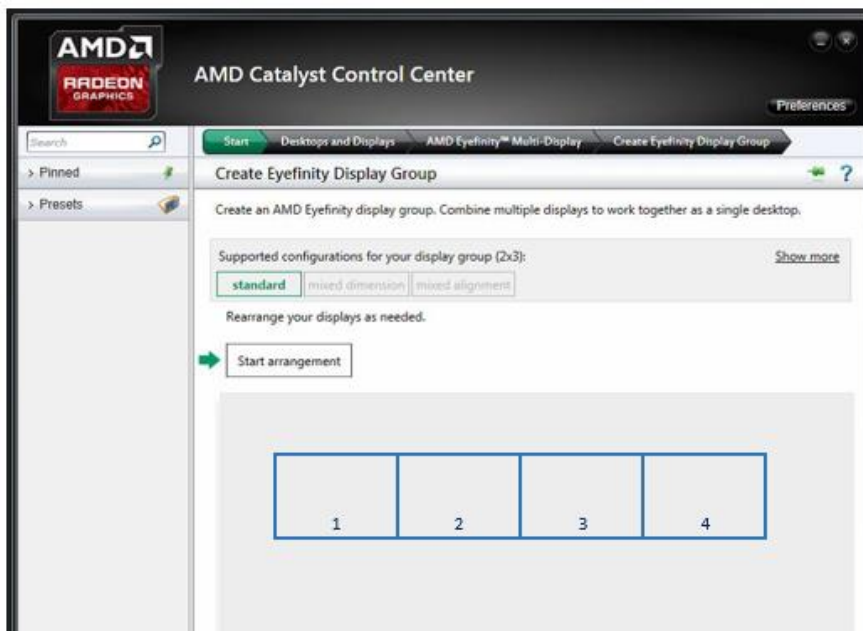

“4 x1” (Landscape) for 8 x 1 Display configuration with 15360 x 1200 resolution



B. 4 x 2 Display configuration

(1) Select “1 x 4 Stretch” by control center utility



(2) Create Eyefinity Display Group "2 x 2" with AMD Eyefinity

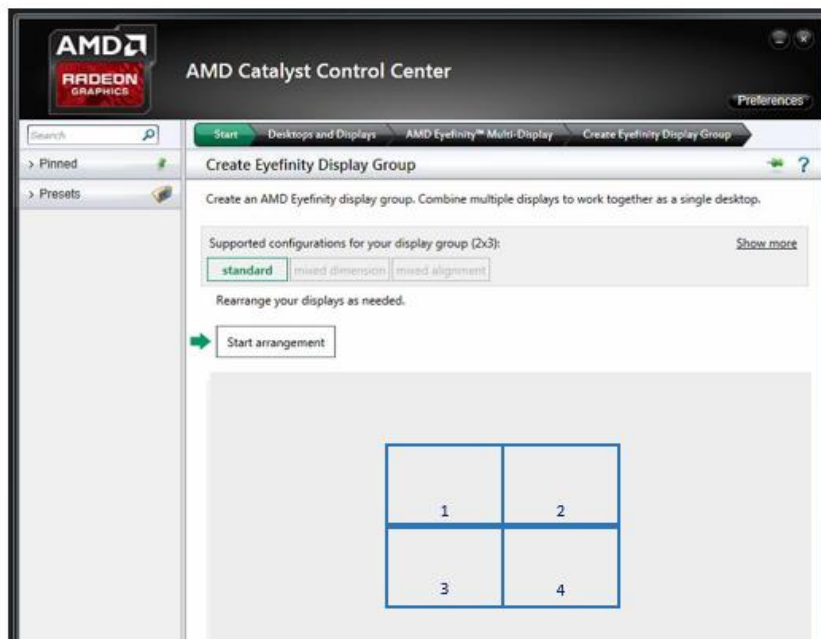

"2 x 2" (Landscape) for 4 x 2 Display configuration with 7680 x 2400 resolution



4 x 2 Landscape

C. 6 x 2 Display configuration

(1) Select “2 x 2 Stretch” by control center utility



(2) Create Eyefinity Display Group p"3 x 2" with AMD Eyefinity

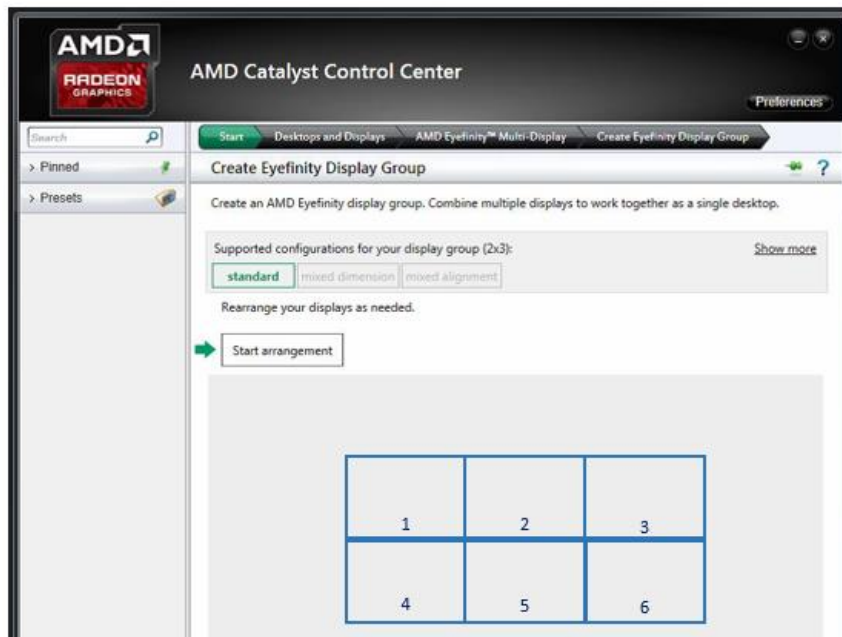

“3 x 2” (Landscape) for 6 x 2 Display configuration with 11520 x 2400 resolution



6 x 2 Landscape

D. 2 x 4 Display configuration

(1) Select “2 x 2 Stretch” by control center utility



(2) Create Eyefinity Display Group p"1 x 4" with AMD Eyefinity

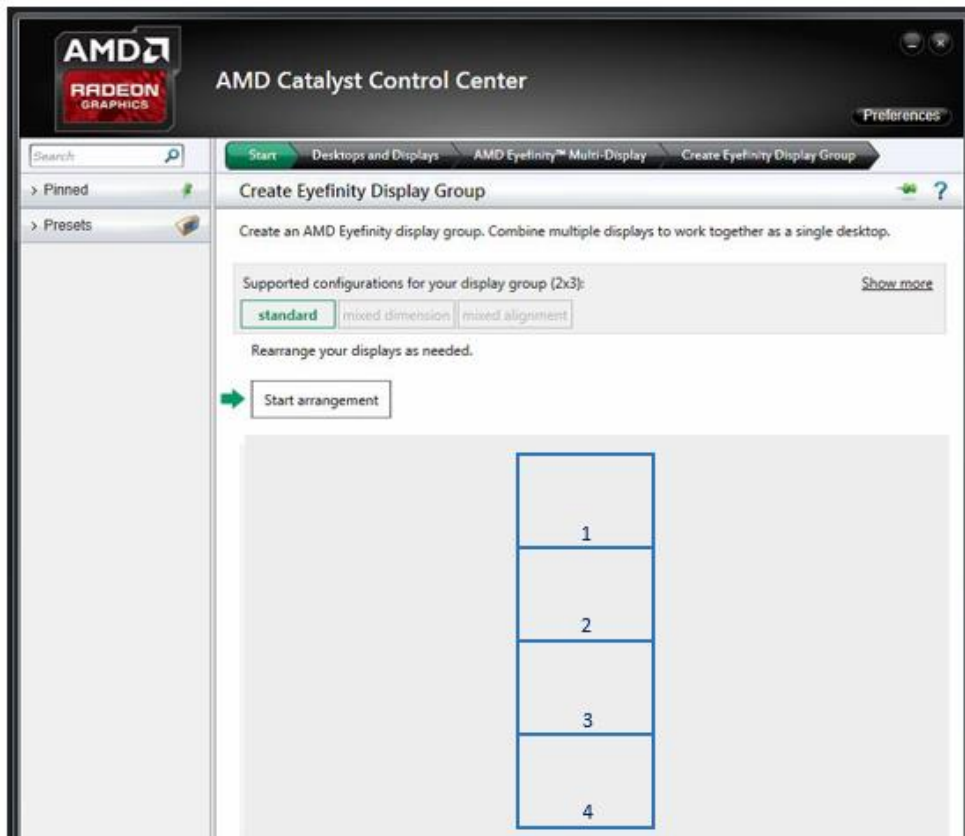

"1 x 4" (Landscape) for 2 x 4 Display configuration with 3840 x 4800 resolution

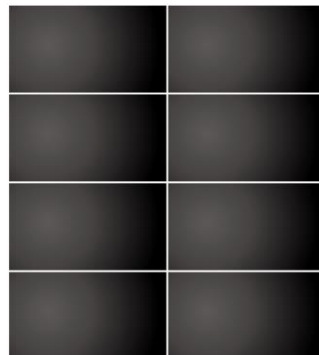

2 x 4 Landscape

1.5 SI-60E Bezel adjustment for 4 x 3 Display configuration

First, please do check and confirm your DP output is correct; also set SI-60E control center "**Clock Sync**" as "**off**".

Then you can start to use Bezel adjustment function.

Please use AMD Eyefinity Arrangement to re-arrange the DP output, then start to do the Bezel adjustment in each DP first. (Red line area)



After you have finished the red line area bezel adjustment, you can start to use SI-60E Control panel to do the Bezel Adjustment with “H bezel” (Yellow Line) as shown below.

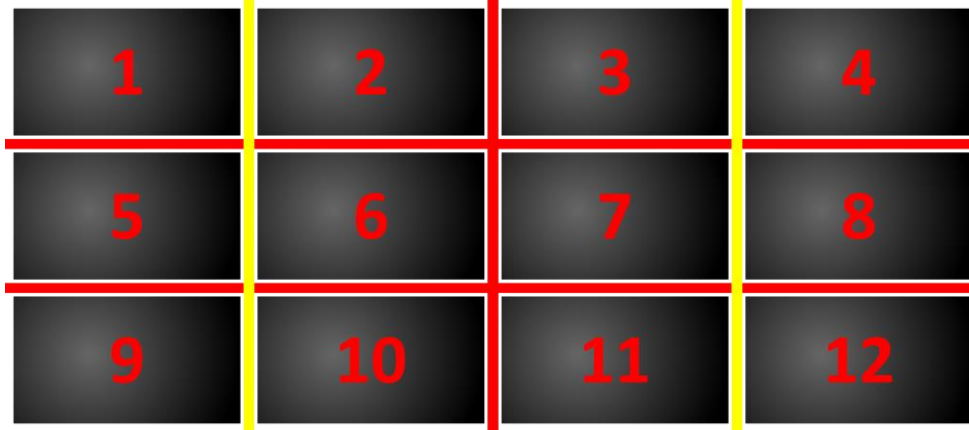

C. IDD100 LED Indicator Description

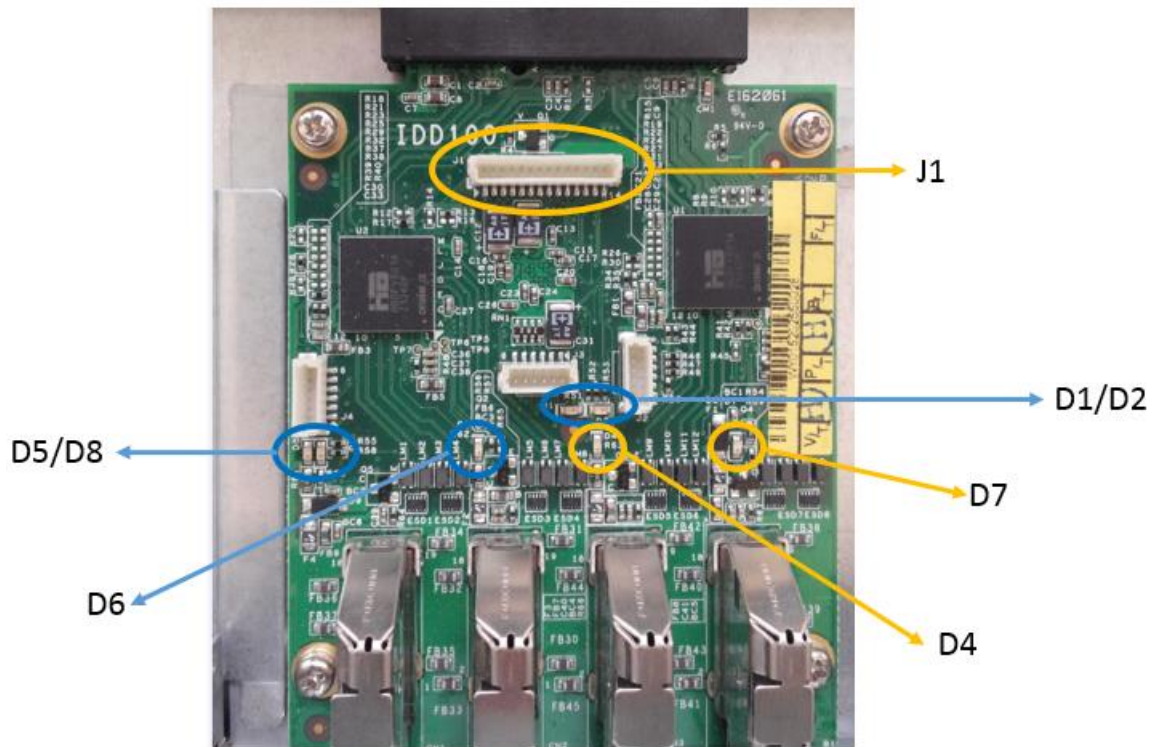

D1: Power Done

D7/D6: Video ASIC FW Ready

D4/D5: HDMI Port Program Ready

D2/D8: DP Port 1/2 Ready, LED Flash: DP handshake fail.

J1 OLED Display: FPGA Code Ready

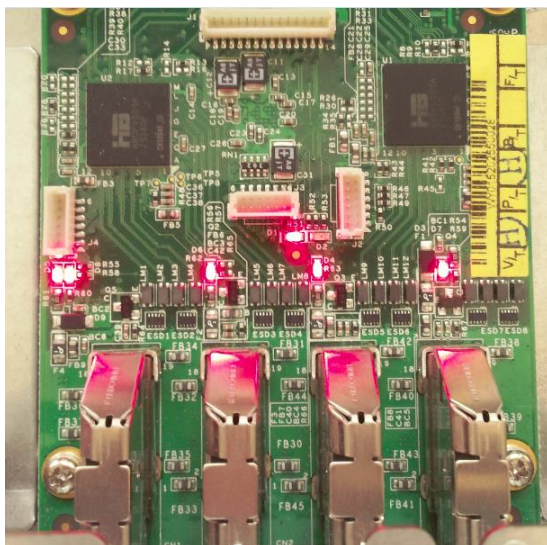

D. I/O Port Address Map

Each peripheral device in the system is assigned a set of I/O port addresses which also becomes the identity of the device. The following table lists the I/O port addresses used.

Address	Device Description
0000h-001Fh	Direct memory access controller
0000h-0CF7h	PCI bus
0040h-0043h	System timer
0050h-0053h	System timer
0070h-0077h	System CMOS/real time clock
0081h-0091h	Direct memory access controller
0093h-009Fh	Direct memory access controller
00C0h-00DFh	Direct memory access controller
00F0h-00F0h	Numeric data processor
02F8h-02FFh	Communications Port (COM2)
03B0h-03BBh	AMD Radeon E8860
03C0h-03DFh	AMD Radeon E8860
03F8h-03FFh	Communications Port (COM1)
0D00h-FFFFh	PCI bus
D000h-DFFFh	Intel(R) 8 Series/C220 Series PCI Express Root Port #7 - 8C1C
E000h-E0FFh	AMD Radeon E8860
F040h-F05Fh	Intel(R) 8 Series/C220 Series SMBus Controller - 8C22
F060h-F07Fh	Intel(R) 8 Series/C220 Series SATA AHCI Controller - 8C02
F0A0h-F0A3h	Intel(R) 8 Series/C220 Series SATA AHCI Controller - 8C02
F0B0h-F0B7h	Intel(R) 8 Series/C220 Series SATA AHCI Controller - 8C02
F0C0h-F0C3h	Intel(R) 8 Series/C220 Series SATA AHCI Controller - 8C02
F0D0h-F0D7h	Intel(R) 8 Series/C220 Series SATA AHCI Controller - 8C02
F0E0h-F0E7h	Intel(R) Active Management Technology - SOL (COM3)

E. Interrupt Request Lines (IRQ)

Peripheral devices use interrupt request lines to notify CPU for the service required. The following table shows the IRQ used by the devices on board.

Level	Function
IRQ0	System Timer
IRQ3	Serial Port #2
IRQ4	Serial Port #1
IRQ 5	Intel(R) 8 Series/C220 Series SMBus Controller - 8C22
IRQ 13	Numeric data processor
IRQ 16	High Definition Audio Controller
IRQ 16	Intel(R) 8 Series/C220 Series USB EHCI #2 - 8C2D
IRQ 19	Intel(R) 8 Series/C220 Series SATA AHCI Controller - 8C02
IRQ 19	Intel(R) Active Management Technology - SOL (COM3)
IRQ 22	High Definition Audio Controller
IRQ 23	Intel(R) 8 Series/C220 Series USB EHCI #1 - 8C26

F. Watchdog Timer Configuration

The WDT is used to generate a variety of output signals after a user programmable count. The WDT is suitable for use in the prevention of system lock-up, such as when software becomes trapped in a deadlock. Under these sorts of circumstances, the timer will count to zero and the selected outputs will be driven. Under normal circumstance, the user will restart the WDT at regular intervals before the timer counts to zero.

SAMPLE CODE:

```
//-----  
//  
// THIS CODE AND INFORMATION IS PROVIDED "AS IS" WITHOUT WARRANTY OF ANY  
// KIND, EITHER EXPRESSED OR IMPLIED, INCLUDING BUT NOT LIMITED TO THE  
// IMPLIED WARRANTIES OF MERCHANTABILITY AND/OR FITNESS FOR A PARTICULAR  
// PURPOSE.  
//  
//-----  
#include <dos.h>  
#include <conio.h>  
#include <stdio.h>  
#include <stdlib.h>  
#include "F81846.H"  
//-----  
int main (int argc, char *argv[]);  
void EnableWDT(int);  
void DisableWDT(void);  
//-----  
int main (int argc, char *argv[])  
{  
    unsigned char bBuf;  
    unsigned char bTime;  
    char **endptr;  
  
    char SIO;  
  
    printf("Fintek 81866 watch dog program\n");  
  
    SIO = Init_F81846();  
    if (SIO == 0)  
    {  
        printf("Can not detect Fintek 81866, program abort.\n");  
        return(1);  
    }  
    }  
}
```

```
if (argc != 2)
{
printf(" Parameter incorrect!!\n");
return (1);
}

bTime = strtol (argv[1], endptr, 10);
printf("System will reset after %d seconds\n", bTime);

if (bTime)
{
EnableWDT(bTime);
}
else
{
DisableWDT();
}

return 0;
```

```

}
//-----
void EnableWDT(int interval)
{
unsigned char bBuf;

bBuf = Get_F81846_Reg(0x2B);
bBuf &= (~0x20);
Set_F81846_Reg(0x2B, bBuf);

//Enable WDTO

Set_F81846_LD(0x07);

//switch to logic device 7

Set_F81846_Reg(0x30, 0x01);

//enable timer

bBuf = Get_F81846_Reg(0xF5);
bBuf &= (~0x0F);
bBuf |= 0x52;
Set_F81846_Reg(0xF5, bBuf);

//count mode is second

Set_F81846_Reg(0xF6, interval);

//set timer

bBuf = Get_F81846_Reg(0xFA);
bBuf |= 0x01;

```

```
Set_F81846_Reg(0xFA, bBuf);
```

```
//enable WDTO output
```

```
bBuf = Get_F81846_Reg(0xF5);  
bBuf |= 0x20;  
Set_F81846_Reg(0xF5, bBuf);
```

```
//start counting
```

```
}
```

```
//-----
```

```
void DisableWDT(void)
```

```
{
```

```
unsigned char bBuf;
```

```
Set_F81846_LD(0x07);
```

```
//switch to logic device 7
```

```
bBuf = Get_F81846_Reg(0xFA);  
bBuf &= ~0x01;  
Set_F81846_Reg(0xFA, bBuf);
```

```
//disable WDTO output
```

```
bBuf = Get_F81846_Reg(0xF5);  
bBuf &= ~0x20;  
bBuf |= 0x40;  
Set_F81846_Reg(0xF5, bBuf);
```

```
//disable WDT
```

```
}
```

```
//-----
```

```

//-----
//
// THIS CODE AND INFORMATION IS PROVIDED "AS IS" WITHOUT WARRANTY OF ANY
// KIND, EITHER EXPRESSED OR IMPLIED, INCLUDING BUT NOT LIMITED TO THE
// IMPLIED WARRANTIES OF MERCHANTABILITY AND/OR FITNESS FOR A PARTICULAR
// PURPOSE.
//
//-----
#include "F81846.H"
#include <dos.h>
//-----
unsigned int F81846_BASE;
void Unlock_F81846 (void);
void Lock_F81846 (void);
//-----
unsigned int Init_F81846(void)
{
    unsigned int result;
    unsigned char ucDid;

    F81846_BASE = 0x4E;
    result = F81846_BASE;

    ucDid = Get_F81846_Reg(0x20);
    if (ucDid == 0x07)

        {
            //Fintek 81866
            goto Init_Finish;
        }

    F81846_BASE = 0x2E;
    result = F81846_BASE;

    ucDid = Get_F81846_Reg(0x20);
    if (ucDid == 0x07)

        {
            //Fintek 81866
            goto Init_Finish;
        }

    F81846_BASE = 0x00;
    result = F81846_BASE;

    Init_Finish:
    return (result);
}
//-----
void Unlock_F81846 (void)
{
    outportb(F81846_INDEX_PORT, F81846_UNLOCK);
    outportb(F81846_INDEX_PORT, F81846_UNLOCK);
}
//-----
void Lock_F81846 (void)
{
    outportb(F81846_INDEX_PORT, F81846_LOCK);
}

```

```

//-----
void Set_F81846_LD( unsigned char LD)
{
Unlock_F81846();
outportb(F81846_INDEX_PORT, F81846_REG_LD);
outportb(F81846_DATA_PORT, LD);
Lock_F81846();
}
//-----
void Set_F81846_Reg( unsigned char REG, unsigned char DATA)
{
Unlock_F81846();
outportb(F81846_INDEX_PORT, REG);
outportb(F81846_DATA_PORT, DATA);
Lock_F81846();
}
//-----

unsigned char Get_F81846_Reg(unsigned char REG)
{
unsigned char Result;
Unlock_F81846();
outportb(F81846_INDEX_PORT, REG);
Result = inportb(F81846_DATA_PORT);
Lock_F81846();
return Result;
}
//-----

```

```

//-----
//
// THIS CODE AND INFORMATION IS PROVIDED "AS IS" WITHOUT WARRANTY OF ANY
// KIND, EITHER EXPRESSED OR IMPLIED, INCLUDING BUT NOT LIMITED TO THE
// IMPLIED WARRANTIES OF MERCHANTABILITY AND/OR FITNESS FOR A PARTICULAR
// PURPOSE.
//
//-----
#ifndef __F81846_H
#define __F81846_H

//-----
#define F81846_INDEX_PORT 1

#define (F81846_BASE)
F81846_DATA_PORT

(F81846_BASE+1)

//-----
#define F81846_REG_LD 0x07

//-----
#define F81846_UNLOCK 0x87

#define F81846_LOCK 0xAA

//-----
unsigned int Init_F81846(void);
void Set_F81846_LD( unsigned char);
void Set_F81846_Reg( unsigned char, unsigned char);
unsigned char Get_F81846_Reg( unsigned char);
//-----
#endif
__F81846_H

```