



DYNATRON

The Thermal Solution Architect

WWW.DYNATRON.CO

Product Spec Sheet

B12

Table of Contents

1. Product Description	3
2. Thermal Performance Curve	3
3. DM Drawing	4
4. EP Drawing	5
5. RoHS Certificate.....	6

Application :

- Recommend for Intel® Xeon® Platinum / Gold Family Processor (Products formerly Skylake), Socket FCLGA3647
- **For Square ILM Only**
- Passive Cooler for 2U Server and up

Overall Specification :

- Dimension: 90 x 90 x 64 mm
- Weight: 590 g
- Material : Aluminum Heatsink, Copper Base with Heatpipes Embedded
- Convenient Heat Sink Screw captive mounting
- Thermal Grease Shin-Etsu 7762 Pre-printed
- Support CPU power up to 205 Watts heat dissipation
- Includes Package Carrier for Processor Installation

Active Cooler B12 Thermal Performance Curve :

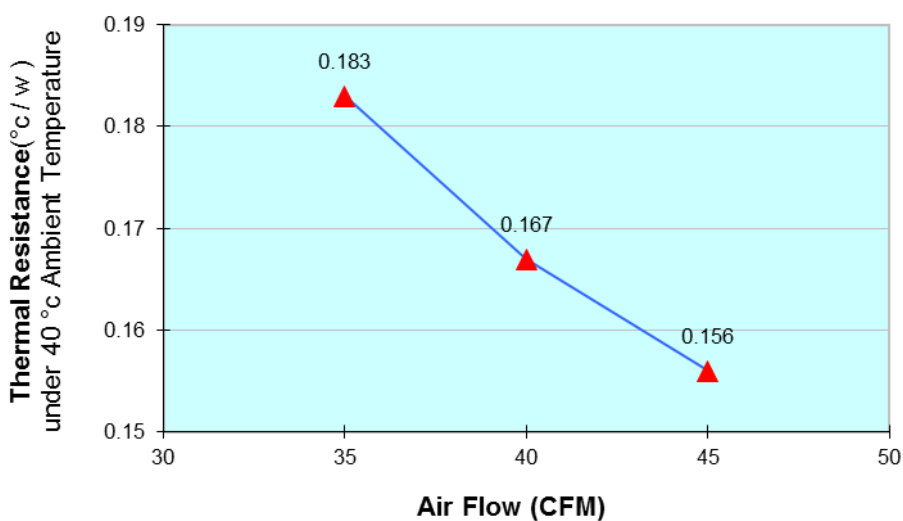

REV#	DESCRIPTION	CHECKER	DATE
0.0	INITIAL RELEASE	LANG	03/14/17

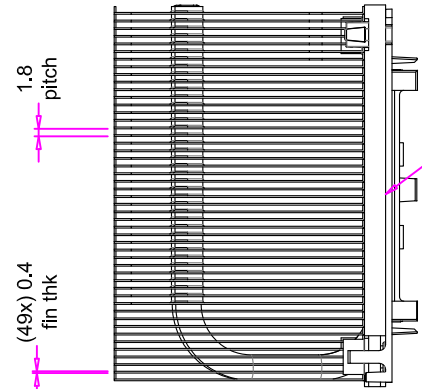
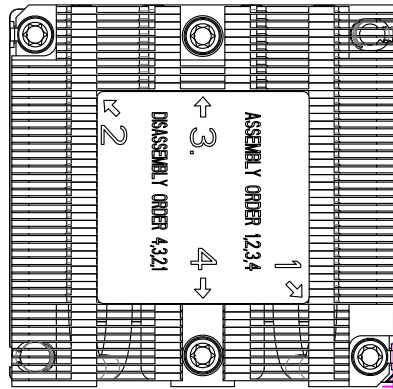
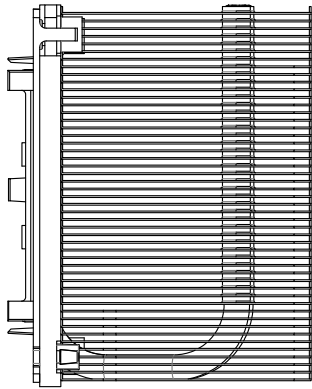
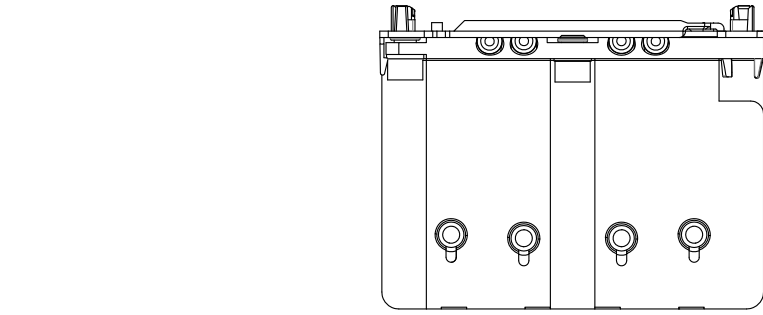

90 ±0.3
 90 ±0.3
 64 ±0.3
 Heatsink Overall Height
 1.8 pitch
 (49x) 0.4 fin thk

0.10
 Ra < 1.2
 MILL

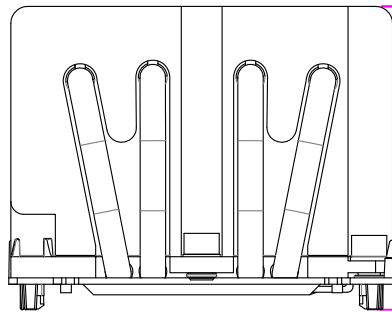

(71.5)

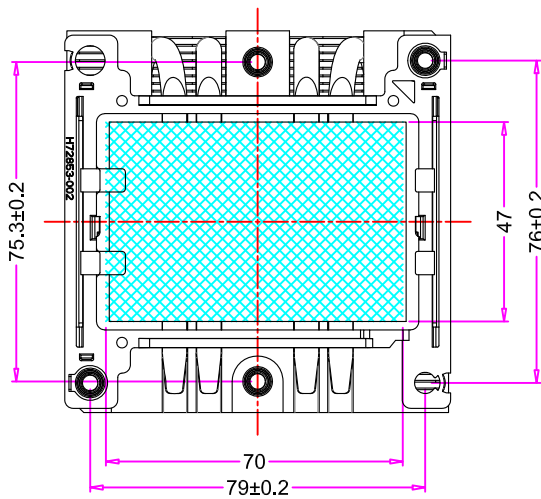

	NAME	DATE
DRAWN BY	ENGR	03/14/2017
CHECKED BY	LANG	03/14/2017
ENG. APPROVED		
MFG. APPROVED	-	-



DYNATRON CORPORATION

TOP MOTOR

TITLE: 2U Passive Cooler **B12**
 Overall Dimension Drawing

CONFIDENTIAL DOCUMENT
 THIS DRAWING CONTAINS INFORMATION PROPRIETARY TO DYNATRON CORPORATION AND DYNAEON INDUSTRIAL CO., LTD. ANY REPRODUCTION, DISCLOSURE, OR USE OF THIS DRAWING IS EXPRESSLY PROHIBITED EXCEPT AS DYNATRON CORPORATION AND DYNAEON INDUSTRIAL CO., LTD. MAY OTHERWISE AGREE TO IN WRITING.

VIEW	
UNITS	MM

DWG. No: **DYN-DM-B12**

REV. **0.0**

CONFIDENTIAL DOCUMENT

THIS DRAWING CONTAINS INFORMATION PROPRIETARY TO DYNATRON CORPORATION AND DYNAEON INDUSTRIAL CO., LTD. ANY REPRODUCTION, DISCLOSURE, OR USE OF THIS DRAWING IS EXPRESSLY PROHIBITED EXCEPT AS DYNATRON CORPORATION AND DYNAEON INDUSTRIAL CO., LTD. MAY OTHERWISE AGREE TO IN WRITING.

ASSEMBLY PARTS

WHOLE SET OF HEATSINK

REV#	DESCRIPTION	CHECKER	DATE
0.0	INITIAL RELEASE	LANG	03/14/2017

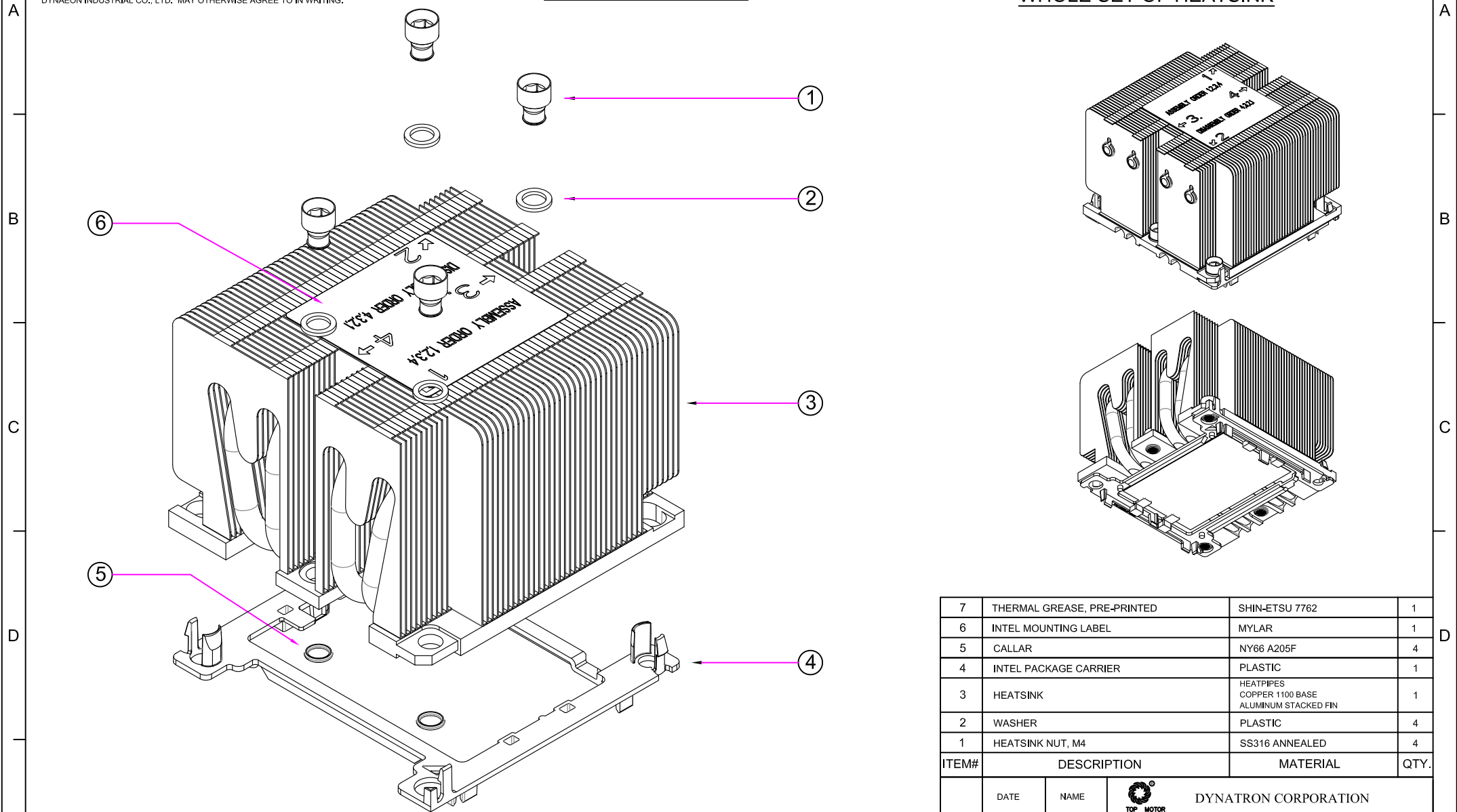

NOTES:

1. THE FIGURE IS FOR REFERENCE ONLY, AND NOT FOR SCALE
2. OVERALL DIMENSION : 90 x 90 x 64mm
3. OVERALL WEIGHT : 590g

7	THERMAL GREASE, PRE-PRINTED	SHIN-ETSU 7762	1
6	INTEL MOUNTING LABEL	MYLAR	1
5	CALLAR	NY66 A205F	4
4	INTEL PACKAGE CARRIER	PLASTIC	1
3	HEATSINK	HEATPIPES COPPER 1100 BASE ALUMINUM STACKED FIN	1
2	WASHER	PLASTIC	4
1	HEATSINK NUT, M4	SS316 ANNEALED	4
ITEM#	DESCRIPTION	MATERIAL	QTY.

	DATE	NAME	 DYNATRON CORPORATION			
DRAWN	03/14/2017	Engr				
CHECKED	03/14/2017	LANG	TITLE: 2U Passive Cooler B12 BOM & Exploded Assembly Drawing			
ENG. APPR.						
MFG. APPR.						
G.A.						
COMMENTS:			DWG. No:	DYN-EP-B12	REV	0.0



Certificate of Environment Protection

環保證明書

Document Number: RH-B12-R0

Customer: 客戶名稱:	Company: _____ Address: _____ Phone Number: _____ - _____ - _____
Issue Date:	06/02/2016
Product Model Number:	B12
<p> Dynatron Corporation hereby declares and certifies that all components manufactured are RoHS compliant according to the definitions and restrictions given by the European Union's Restriction (Directive 2002/95/EC) (Decision2011/65/EU)RoHS 2, on the restriction of the use of certain Hazardous Substances in the electrical and electronic equipment. Also, compliance to the most recent list of substances on the REACH candidate list. </p> <p> Number of substances on the Candidate List: 168 (last updated: 17/12/2015) </p> <p> No exemptions are claimed in order for the part to be compliant with the RoHS directive. </p> <p> Dynatron Corporation / 政久興業股份有限公司證明所有產品,零件 (包括附屬品, 包裝類) 之環境管理物質完全符合 RoHS, WEEE, 及該環保標準之規定, 並承諾遵 循以上之證明。 </p> <div style="text-align: right; margin-top: 20px;"> <p> Dynatron Corporation. 33200 Western Ave, Union City, CA 94587 www.Dynatron-corp.com </p> </div> <p style="margin-top: 20px;"> Title (職務): _____ ASSISTANT-MANAGER _____ </p> <p style="margin-top: 10px;"> Signature (簽字): _____  _____ </p> <p style="text-align: right; margin-top: 5px;"> Date: 06 / 02 / 2016 </p>	