



DYNATRON

The Thermal Solution Architect

WWW.DYNATRON.CO

Product Spec Sheet

B9

Table of Contents

1. Product Description	3
2. Thermal Performance Curve	4
3. DM Drawing	5
4. EP Drawing	6
5. RoHS Certificate.....	7

Application :

- Recommend for Intel® Xeon® Platinum / Gold Family Processor (Products formerly Skylake), Socket FCLGA3647
- **For Square ILM Only**
- Active Cooler for 1U Server and up

Overall Specification :

- Dimension: 93 x 90.5 x 28 mm
- Weight: 470 g
- Material : Copper1100 Heatsink with Vapor Chamber Base
- 9015 Aluminum Frame PWM Blower for Heat Exhausting
- Convenient Heat Sink Screw captive mounting
- Thermal Grease Shin-Etsu 7762 Pre-printed
- Support CPU power up to 205 Watts heat dissipation
- Includes Package Carrier for Processor Installation

Blower Specification:

- Model Number: DF129015BH-PWM
- Dimension: Ø90 x 15 mm
- Bearing: Ball Type, Double
- Rated Voltage: 12V
- Rated Speed:
 - At Duty Cycle 0~20%: 1000 ± 200 RPM
 - At Duty Cycle 50%: 2500 ± 10% RPM
 - At Duty Cycle 100%: 5000 ± 10% RPM
- Rated Input Power:
 - At Duty Cycle 0~20%: 1.2 W
 - At Duty Cycle 50%: 2.6 W
 - At Duty Cycle 100%: 12 W
- Rated Airflow:
 - At Duty Cycle 0~20%: 6.8 CFM
 - At Duty Cycle 50%: 11.0 CFM
 - At Duty Cycle 100%: 19.0 CFM

- Rated Static Pressure:
 - At Duty Cycle 0~20%: 2.8 mm-H₂O
 - At Duty Cycle 50%: 18 mm-H₂O
 - At Duty Cycle 100%: 46 mm-H₂O

- Rated Acoustical Noise:
 - At Duty Cycle 0~20%: 16 dBA
 - At Duty Cycle 50%: 31.5 dBA
 - At Duty Cycle 100%: 46.4 dBA

- Lead Wire Pin Out:
 - Pin#1-Black(-)
 - Pin#2- Yellow(+)
 - Pin#3- Green(Tachometer/ Signal Output)
 - Pin#4- Blue (PWM)

- Lead Wire Pin Out Diagram :

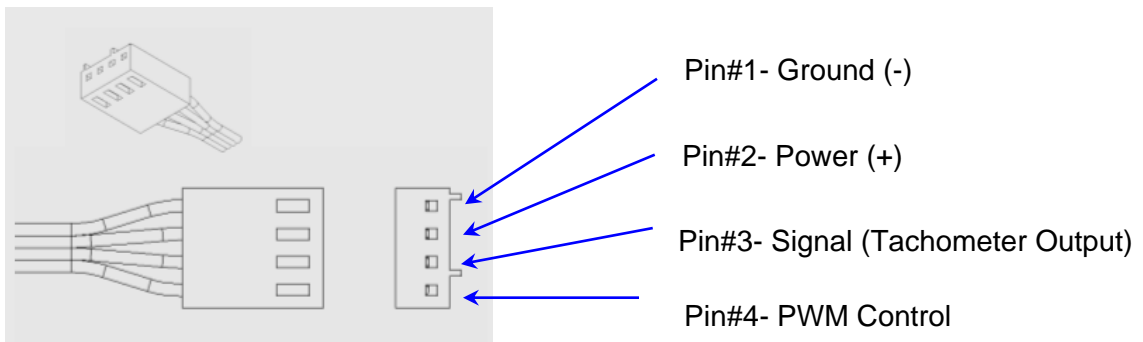

Active Cooler B9 Thermal Performance Curve :

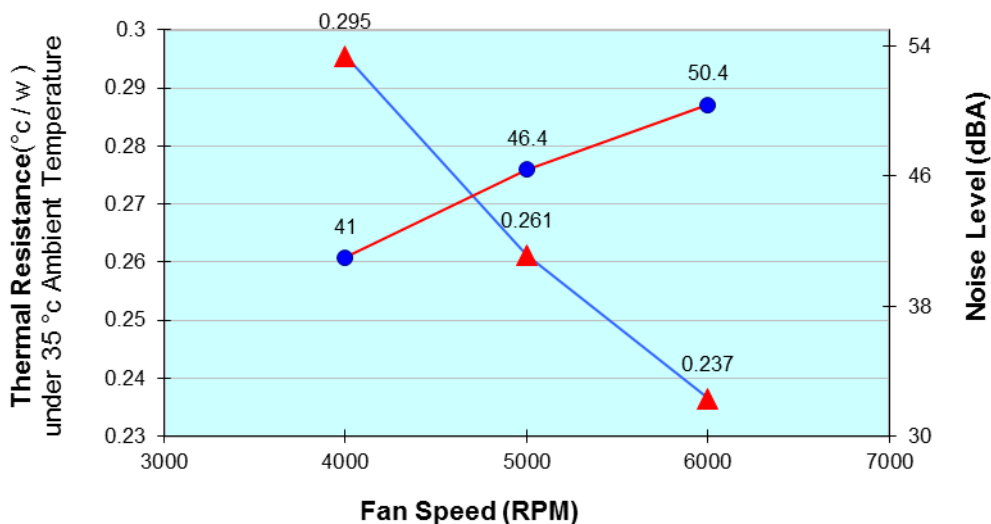

REV#	DESCRIPTION	CHECKER	DATE
0.0	INITIAL RELEASE	LANG	03/14/17

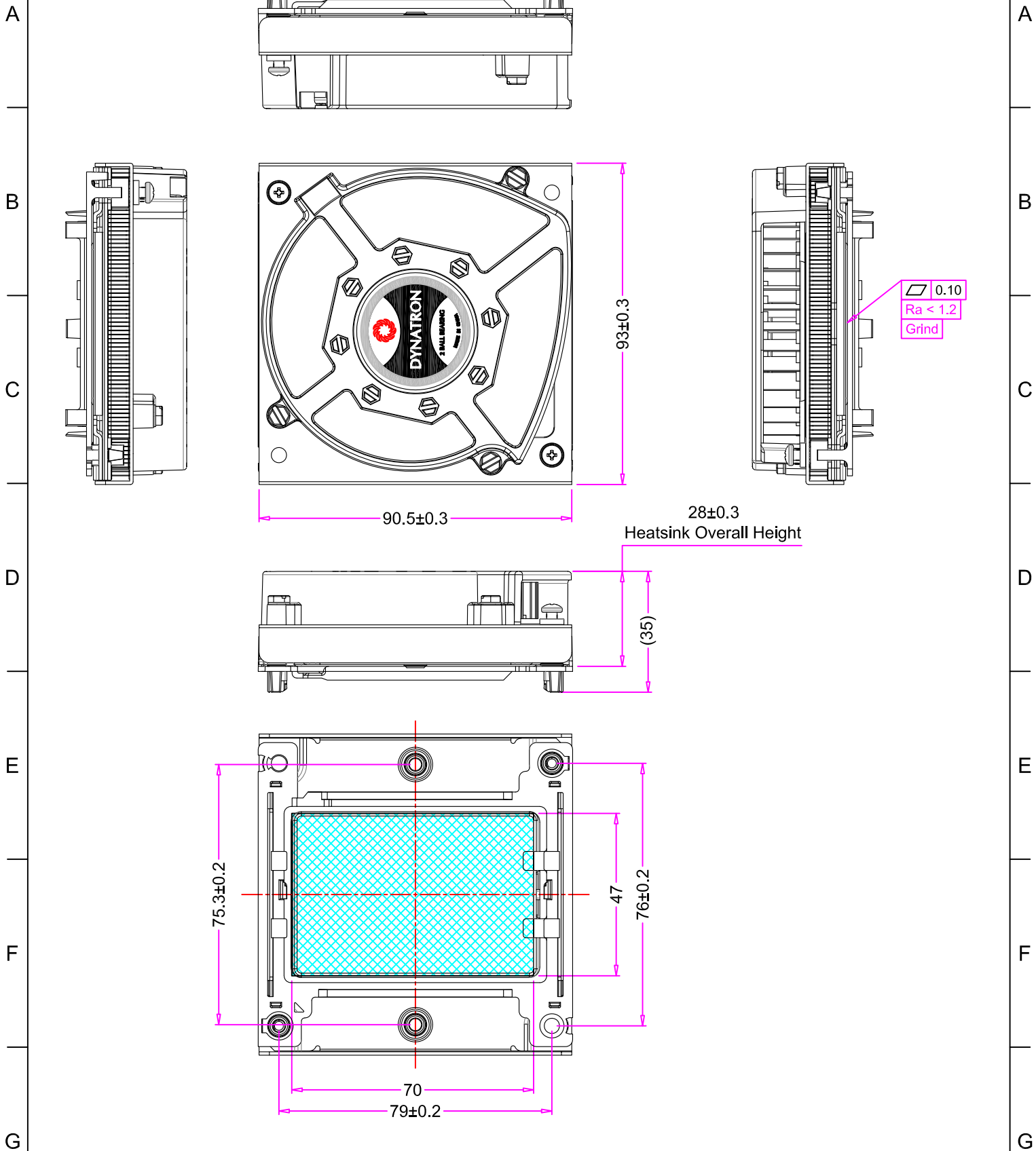

	NAME	DATE
DRAWN BY	ENGR	03/14/2017
CHECKED BY	LANG	03/14/2017
ENG. APPROVED		
MFG. APPROVED	-	-



DYNATRON CORPORATION

TITLE: 1U Active Cooler **B9**
Overall Dimension Drawing

CONFIDENTIAL DOCUMENT
THIS DRAWING CONTAINS INFORMATION PROPRIETARY TO DYNATRON CORPORATION AND DYNAEON INDUSTRIAL CO., LTD. ANY REPRODUCTION, DISCLOSURE, OR USE OF THIS DRAWING IS EXPRESSLY PROHIBITED EXCEPT AS DYNATRON CORPORATION AND DYNAEON INDUSTRIAL CO., LTD. MAY OTHERWISE AGREE TO IN WRITING.

VIEW	
UNITS	MM

DWG. No:	DYN-DM-B9
----------	-----------

REV.	0.0
------	-----

CONFIDENTIAL DOCUMENT

THIS DRAWING CONTAINS INFORMATION PROPRIETARY TO DYNATRON CORPORATION AND DYNAEON INDUSTRIAL CO., LTD. ANY REPRODUCTION, DISCLOSURE, OR USE OF THIS DRAWING IS EXPRESSLY PROHIBITED EXCEPT AS DYNATRON CORPORATION AND DYNAEON INDUSTRIAL CO., LTD. MAY OTHERWISE AGREE TO IN WRITING.

ASSEMBLY PARTS

REV#	DESCRIPTION	CHECKER	DATE
0.0	INITIAL RELEASE	LANG	03/14/2017

WHOLE SET OF HEATSINK

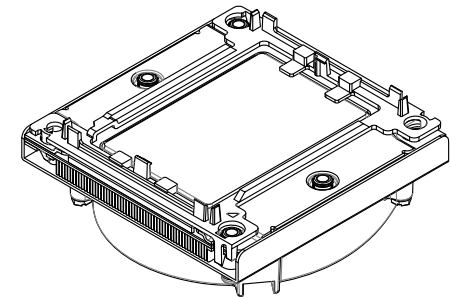
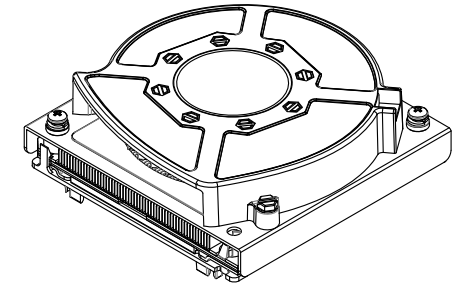
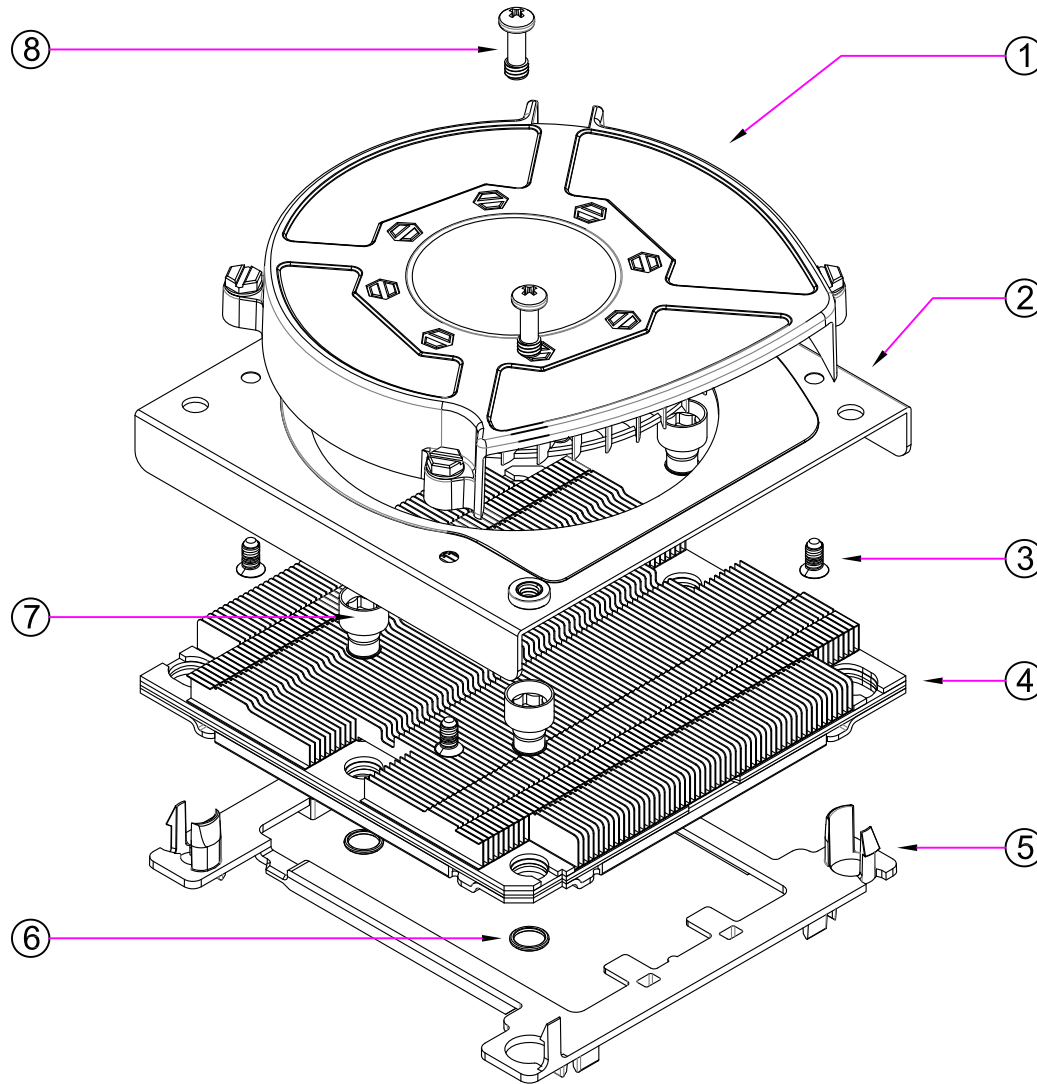

9	THERMAL GREASE, PRE-PRINT	SHIN-ETSU 7762	1
8	SCREW, BLOWER COVER MOUNTING	STEEL	2
7	HEATSINK NUT, M4	SUS 316 ANNEALED	4
6	CALLAR	NY66 A205F	4
5	INTEL PACKAGE CARRIER	PLASTIC	1
4	HEATSINK, STACKED FIN	COPPER 1100, VC BASE SK7 STIFFENER COPPER 1100 FIN	1
3	SCREW, BLOWER MOUNTING	STEEL	4
2	BLOWER COVER	ALUMINUM	1
1	BLOWER, DB129015BU-PWM (6000RPM)	ALUMINUM FRAME	1
ITEM#	DESCRIPTION	MATERIAL	QTY.

NOTES:

1. THE FIGURE IS FOR REFERENCE ONLY, AND NOT FOR SCALE
2. OVERALL DIMENSION : 93 x 90.5 x 28 mm
3. OVERALL WEIGHT : 470g

	DATE	NAME	DYNATRON CORPORATION
DRAWN	03/14/2017	Engr	TITLE: 1U Active Cooler B9 BOM & Exploded Assembly Drawing
CHECKED	03/14/2017	LANG	
ENG. APPR.			
MFG. APPR.			
O.A.			
COMMENTS:	DWG. No:		REV
	DYN-EP-B9		0.0



Certificate of Environment Protection

環保證明書

Document Number: RH-B9-R0

Customer: 客戶名稱:	Company: _____ Address: _____ Phone Number: ____ - ____ - _____
Issue Date:	06/02/2016
Product Model Number:	B9
<p>Dynatron Corporation hereby declares and certifies that all components manufactured are RoHS compliant according to the definitions and restrictions given by the European Union's Restriction (Directive 2002/95/EC) (Decision2011/65/EU)RoHS 2, on the restriction of the use of certain Hazardous Substances in the electrical and electronic equipment. Also, compliance to the most recent list of substances on the REACH candidate list.</p> <p>Number of substances on the Candidate List: 168 (last updated: 17/12/2015)</p> <p>No exemptions are claimed in order for the part to be compliant with the RoHS directive.</p> <p>Dynatron Corporation / 政久興業股份有限公司證明所有產品,零件 (包括附屬品, 包裝類) 之環境管理物質完全符合 RoHS, WEEE, 及該環保標準之規定, 並承諾遵循以上之證明.</p> <div style="text-align: right; margin-top: 20px;"> <p>Dynatron Corporation. 33200 Western Ave, Union City, CA 94587 www.Dynatron-corp.com</p> </div> <p style="margin-top: 20px;"> Title (職務): _____ ASSISTANT-MANAGER </p> <p style="margin-top: 10px;"> Signature (簽字): _____ <i>Van Lee</i> </p> <p style="text-align: right; margin-top: 10px;">Date: 06 / 02 / 2016</p>	