

SATADOM D150QV-L



Features

- Zero mechanical interference
- S.M.A.R.T. & i-S.M.A.R.T. Supported
- Intelligent system for error recovery
- Excellent data transfer speed
- Built-in Pin7 VCC
- Mechanical design for anti-vibration

R: 130MB
W: 120MB

SATA II
3Gb/s

ECC &
Wear leveling

Thermal
sensor

S.M.A.R.T

Pin 7 VCC
Write Protect

Specifications

Connector Type	Standard 7 Pin SATA Connector
Flash Type	SLC (Single Level Cell)
Density	2GB, 4GB, 8GB, 16GB, 32GB, 64GB
Transfer Mode	SATA II, SATA I, PIO 0~4, MDMA 0~2, UDMA 0~6
Sustained R/W Performance	Read : 130 MB/sec (max.) Write : 120 MB/sec (max.)

Environmental

DC Input	+5V DC \pm 5%
Power consumption (Max.)	Read: 260 mA Write: 340 mA Idle: 170 mA
Operating Temperature	0°C~+70°C (Standard Grade) -40°C~+85°C (Industrial Grade)
Storage Temperature	-55°C~+95°C
Humidity	Relative Humidity: 10-95%, non-condensing
Flash Endurance	100,000 program/erase cycles
MTBF	> 3,000,000 hours
Certification	CE, FCC, RoHS
Warranty	5 years

Special Features

Security	Write Protection
Pin7 VCC	Supported (Refer to the following page)

Mechanicals

Dimension (W x L x H)	35.5mm x 30mm x 9.5mm
Weight	9g \pm 1g
Vibration	7 Hz to 2K Hz, 3 axes
Shock	Duration: 0.5ms, 1500G, 3 axes

Health monitoring Tool

S.M.A.R.T.	Supported
i-S.M.A.R.T.	Supported (Utility for Windows, Linux)

Ordering Information

Capacity	Standard Grade	Industrial Grade
2GB	DESIL-02GJ30A C 2DBF	DESIL-02GJ30A W 2DBF
4GB	DESIL-04GJ30A C 2QBF	DESIL-04GJ30A W 2QBF
8GB	DESIL-08GJ30A C 2QBF	DESIL-08GJ30A W 2QBF
16GB	DESIL-16GJ30A C 2QBF	DESIL-16GJ30A W 2QBF
32GB	DESIL-32GJ30A C 2QBF	DESIL-32GJ30A W 2QBF
64GB	DESIL-64GJ30A C 2QBF	DESIL-64GJ30A W 2QBF

Mechanical Dimension

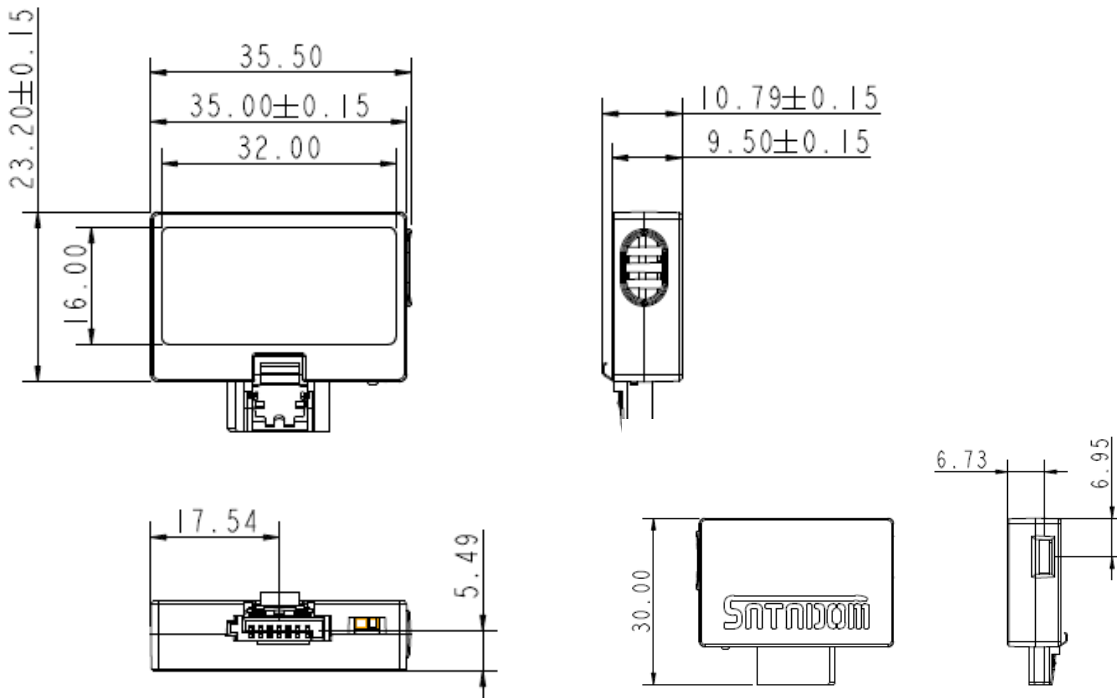

SATADOM D150QV-L mechanical dimensions
(* Tolerance is ±0.15mm)

Pin7 VCC Advantages

1. Customers DO NOT have to use the power cable for the severe condition.
2. Pin7 VCC can cost down the manufactured charge.
3. Followed by our suggested circuit, you can increase the options for SATA device, no matter for InnoDisk SATADOM or other DOM

*SATADOM D150QH with Pin7 VCC is designed with fuse (polyswitch500mA, 6V) on Pin7's circuit

Pin7VCC MB Reference Circuit Design

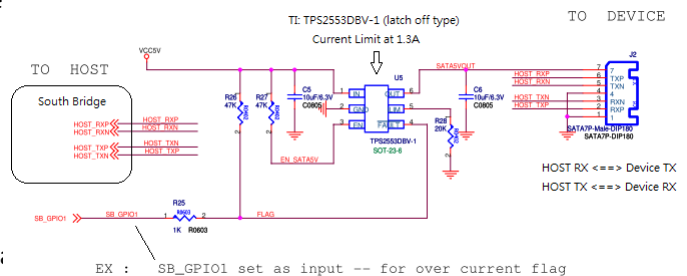

Recommendation for Pin7 VCC

InnoDisk suggests that customers MUST design their board with a fuse to prevent over current. In other words, customers are suggested NOT "directly" layout 5V VCC to SATA socket on board. Therefore, we strongly suggest our below circuit to protect MB or device, either by using "POWER SWITCH" or "JUMPER+FUSE".

DESIGN • SERVICE • QUALITY • DELIVERY

