

CFexpress

3ME2 Series

Customer: _____

Customer

Part

Number: _____

Innodisk

Part

Number: _____

Innodisk

Model Name: _____

Date: _____

Innodisk Approver	Customer Approver

**Total Solution For
Industrial Flash Storage**

Table of contents

LIST OF FIGURES	6
1. PRODUCT OVERVIEW	7
1.1 INTRODUCTION OF INNODISK CFEXPRESS 3ME2	7
1.2 PRODUCT VIEW AND MODELS	7
1.3 PCIe INTERFACE	7
2. PRODUCT SPECIFICATIONS	8
2.1 CAPACITY AND DEVICE PARAMETERS	8
2.2 PERFORMANCE	8
2.3 ELECTRICAL SPECIFICATIONS	8
2.3.1 Power Requirement	8
2.3.2 Power Consumption	8
2.4 ENVIRONMENTAL SPECIFICATIONS	9
2.4.1 Temperature Ranges	9
2.4.2 Humidity	9
2.4.3 Shock and Vibration	9
2.4.4 Mean Time between Failures (MTBF)	9
2.5 CE AND FCC COMPATIBILITY	9
2.6 RoHS COMPLIANCE	10
2.7 RELIABILITY	10
2.8 TRANSFER MODE	10
2.9 PIN ASSIGNMENT	11
2.10 MECHANICAL DIMENSIONS	11
TYPE 2242-D2-B-M	11
2.11 ASSEMBLY WEIGHT	12
2.12 SEEK TIME	12
2.13 NAND FLASH MEMORY	12
3. THEORY OF OPERATION	13
3.1 OVERVIEW	13
3.2 PCIe GEN III X2 CONTROLLER	13
3.3 ERROR DETECTION AND CORRECTION	13
3.4 WEAR-LEVELING	14
3.5 BAD BLOCKS MANAGEMENT	14
3.6 POWER CYCLING	14
3.7 GARBAGE COLLECTION	14
3.8 END TO END DATA PATH PROTECTION	14
3.9 THERMAL MANAGEMENT	14
4. INSTALLATION REQUIREMENTS	15

- 4.1 CFEXPRESS 3ME2 PIN DIRECTIONS 15**
- 4.2 ELECTRICAL CONNECTIONS FOR CFEXPRESS 3ME2..... 15**
- 4.3 DEVICE DRIVE 15**
- 5. SMART / HEALTH INFORMATION.....17**
 - 5.1 GET LOG PAGE(LOG IDENTIFIER 02H) 17**
- 6. PART NUMBER RULE21**
- 7. APPENDIX22**

REVISION HISTORY

Revision	Description	Date
Preliminary 1.0	First release	July, 2018

List of Tables

TABLE 1: DEVICE PARAMETERS.....8

TABLE 2: PERFORMANCE8

TABLE 3: INNODISK CFEXPRESS 3ME2 POWER REQUIREMENT.....8

TABLE 4: POWER CONSUMPTION9

TABLE 5: TEMPERATURE RANGE FOR CFEXPRESS 3ME29

TABLE 6: SHOCK/VIBRATION TESTING FOR CFEXPRESS 3ME29

TABLE 7: CFEXPRESS 3ME2 MTBF9

TABLE 8: CFEXPRESS 3ME2 TBW10

TABLE 9: INNODISK CFEXPRESS 3ME2 PIN ASSIGNMENT11

TABLE 10: GET LOG PAGE – SMART / HEALTH INFORMATION LOG17

List of Figures

FIGURE 1: INNODISK CFEXPRESS 3ME2 (TYPE 2242)7
FIGURE 2: INNODISK CFEXPRESS 3ME2 DIAGRAM..... 11
FIGURE 3: INNODISK CFEXPRESS 3ME2 BLOCK DIAGRAM.....13
FIGURE 4: SIGNAL SEGMENT AND POWER SEGMENT.....15

1. Product Overview

1.1 Introduction of Innodisk CFexpress 3ME2

Innodisk CFexpress 3ME2 is followed by CFexpress 1.0 type B, with PCIe interface and MLC NAND Flash. CFexpress 3ME2 supports PCIe Gen III x2, and it is compliant with NVMe 1.2 providing excellent performance. Moreover, it adopts MLC NAND Flash providing high endurance and reliability. With sophisticated error detection and correction (ECC) functions, the module can ensure full End-to-end Data Path Protection that secures the data transmission between host system and NAND Flash.

Innodisk CFexpress 3ME2 is a small and removable memory card providing low latency and extreme speed but with low power consumption. It is ideal for gaming, edge computing and professional digital recording.

CAUTION *TRIM must be enabled.*

TRIM enables SSD's controller to skip invalid data instead of moving. It can free up significant amount of resources, extends the lifespan of SSD by reducing erase, and write cycles on the SSD. Innodisk's handling of garbage collection along with TRIM command improves write performance on SSDs.

1.2 Product View and Models

Innodisk CFexpress 3ME2 is available in follow capacities within MLC flash ICs.

CFexpress 3ME2 32GB

CFexpress 3ME2 64GB

CFexpress 3ME2 128GB

CFexpress 3ME2 256GB



Figure 1: Innodisk CFexpress 3ME2 (type B)

1.3 PCIe Interface

Innodisk CFexpress 3ME2 supports PCIe Gen III interface and compliant with NVMe 1.2. CFexpress 3ME2 can work under PCIe Gen 1, Gen 2 and Gen 3.

Most of operating systems includes NVMe in-box driver now. For more information about the driver support in each OS, please visit <http://nvmexpress.org/resources/drivers>.

2. Product Specifications

2.1 Capacity and Device Parameters

CFexpress 3ME2 device parameters are shown in Table 1.

Table 1: Device parameters

Capacity	LBA	User Capacity(MB)
32GB	62533296	30,533
64GB	125045424	61,057
128GB	250069680	122,104
256GB	500118192	244,198

2.2 Performance

Burst Transfer Rate: 16.0Gbps

Table 2: Performance

Capacity	32GB	64GB	128GB	256GB
Sequential* Read (max.)	440MB/s	870 MB/s	1300 MB/s	1300 MB/s
Sequential* Write (max.)	50 MB/s	100 MB/s	190 MB/s	340MB/s
4KB Random* Read (QD32)	17000	35000	47000	51000
4KB Random* Write (QD32)	12000	22000	30000	46000

Note: * Performance is based on CrystalDiskMark 5.1.2 with file size 1000MB of Queue Depth 32

2.3 Electrical Specifications

2.3.1 Power Requirement

Table 3: Innodisk CFexpress 3ME2 Power Requirement

Item	Symbol	Rating	Unit
Input voltage	V _{IN}	+3.3 DC +- 5%	V

2.3.2 Power Consumption

Table 4: Power Consumption

Mode	Power Consumption (mA)
Read	768 (rms.)
Write	831 (rms.)
Idle	375 (rms.)

* Target: 256GB CFexpress 3ME2

2.4 Environmental Specifications

2.4.1 Temperature Ranges

Table 5: Temperature range for CFexpress 3ME2

Temperature	Range
Operating	Standard Grade: 0°C to +70°C
	Industrial Grade: -40°C to +85°C
Storage	-55°C to +95°C

2.4.2 Humidity

Relative Humidity: 10-95%, non-condensing

2.4.3 Shock and Vibration

Table 6: Shock/Vibration Testing for CFexpress 3ME2

Reliability	Test Conditions	Reference Standards
Vibration	7 Hz to 2K Hz, 20G, 3 axes	IEC 60068-2-6
Mechanical Shock	Duration: 0.5ms, 1500 G, 3 axes	IEC 60068-2-27

2.4.4 Mean Time between Failures (MTBF)

Table 7 summarizes the MTBF prediction results for various CFexpress 3ME2 configurations. The analysis was performed using a RAM Commander™ failure rate prediction.

- **Failure Rate:** The total number of failures within an item population, divided by the total number of life units expended by that population, during a particular measurement interval under stated condition.
- **Mean Time between Failures (MTBF):** A basic measure of reliability for repairable items: The mean number of life units during which all parts of the item perform within their specified limits, during a particular measurement interval under stated conditions.

Table 7: CFexpress 3ME2 MTBF

Product	Condition	MTBF (Hours)
Innodisk CFexpress 3ME2	Telcordia SR-332 GB, 25°C	>3,000,000

2.5 CE and FCC Compatibility

CFexpress 3ME2 conforms to CE and FCC requirements.

2.6 RoHS Compliance

CFexpress 3ME2 is fully compliant with RoHS directive.

2.7 Reliability

Table 8: CFexpress 3ME2 TBW

Parameter		Value
Read Cycles		Unlimited Read Cycles
Flash endurance		3,000 P/E cycles
Wear-Leveling Algorithm		Support
Bad Blocks Management		Support
Error Correct Code		Support(LDPC)
TBW* (Total Bytes Written) Unit: TB		
Capacity	Sequential workload	Client workload
32GB	93.6	39
64GB	187.2	78.1
128GB	374.4	155.6
256GB	748.8	203.8
* Note:		
<ol style="list-style-type: none"> 1. Sequential: Mainly sequential write, tested by Vdbench. 2. Client: Follow JESD218 Test method and JESD219A Workload, tested by ULINK. (The capacity lower than 64GB client workload is not specified in JEDEC219A, the values are estimated.) 3. Based on out-of-box performance. 		

2.8 Transfer Mode

CFexpress 3ME2 support following transfer mode:

PCIe Gen III 8Gbps

PCIe Gen II 4Gbps

PCIe Gen I 2Gbps

2.9 Pin Assignment

Innodisk CFexpress 3ME2 follows CFexpress 1.0 type B pinout define. See Table 9 for CFexpress 3ME2 pin assignment.

Table 9: Innodisk CFexpress 3ME2 Pin Assignment

Pin No.	Signal #	I/O
21	GND	
20	PETp0	I
19	PETn0	I
18	GND	
17	PERp0	O
16	PERn0	O
15	GND	
14	REFCLK+	I
13	REFCLK-	I
12	INS#	O
11	CLKREQ#	O
10	+3.3V	
9	PERST#	I
8	Reserved(Write protect)	I
7	Reserved	
6	PETp1	I
5	PETn1	I
4	GND	
3	PERp1	O
2	PERn1	O
1	GND	

2.10 Mechanical Dimensions

CFexpress Type B

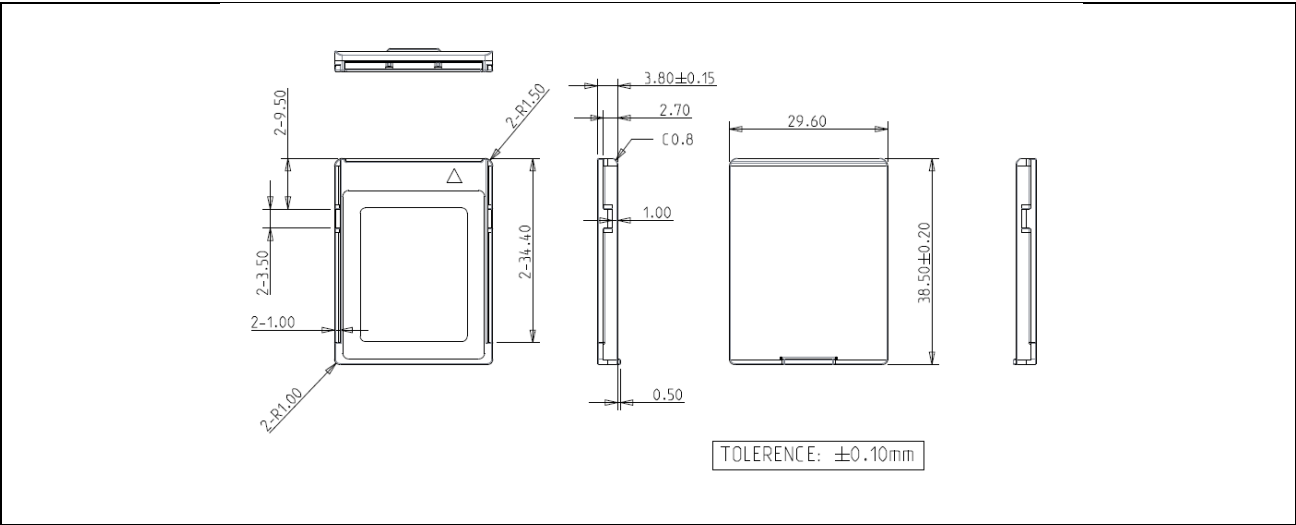

Figure 2: Innodisk CFexpress 3ME2 diagram

2.11 Assembly Weight

An Innodisk CFexpress 3ME2 with NAND flash ICs, 64GB's weight is 7 grams approximately.

2.12 Seek Time

Innodisk CFexpress 3ME2 is not a magnetic rotating design. There is no seek or rotational latency required.

2.13 NAND Flash Memory

Innodisk CFexpress 3ME2 uses Multi Level Cell (MLC) NAND flash memory, which is non-volatility, high reliability and high speed memory storage.

3. Theory of Operation

3.1 Overview

Figure 2 shows the operation of Innodisk CFexpress 3ME2 from the system level, including the major hardware blocks.

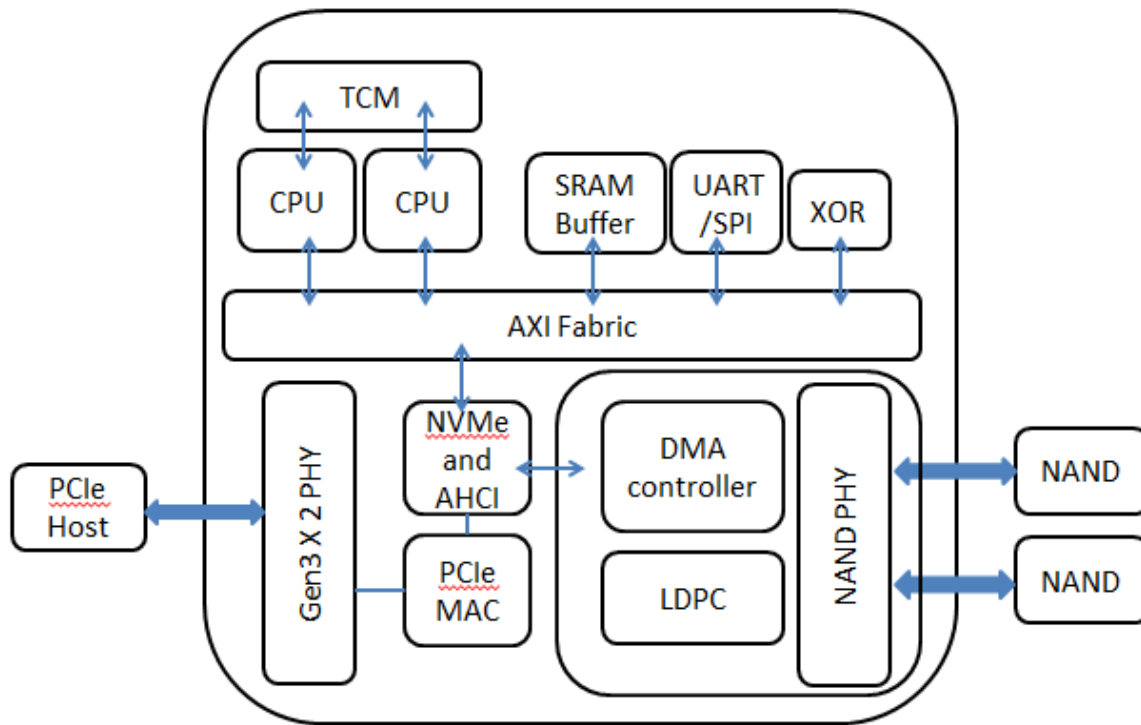

Figure 3: Innodisk CFexpress 3ME2 Block Diagram

Innodisk CFexpress 3ME2 integrates a PCIe Gen III x2 controller and NAND flash memories. Communication with the host occurs through the host interface, using the standard NVM protocol. Communication with the flash device(s) occurs through the flash interface.

3.2 PCIe Gen III x2 Controller

Innodisk CFexpress 3ME2 is designed with 88NV1160, a PCIe Gen IIIx2 controller is compliant with NVMe 1.2, up to 16.0Gbps transfer speed. Also it is compliant with PCIe Gen 1, Gen 2 and Gen 3 specification. The controller supports up to 4 channels for flash interface.

3.3 Error Detection and Correction

Innodisk CFexpress 3ME2 is designed with hardware LDPC ECC engine with hard-decision and soft-decision decoding. Low-density parity-check (LDPC) codes have excellent error correcting performance close to the Shannon limit when decoded with the belief-propagation (BP) algorithm using soft-decision information.

3.4 Wear-Leveling

Flash memory can be erased within a limited number of times. This number is called the **erase cycle limit** or **write endurance limit** and is defined by the flash array vendor. The erase cycle limit applies to each individual erase block in the flash device.

Innodisk CFexpress 3ME2 uses a combination of two types of wear leveling- dynamic and static wear leveling- to distribute write cycling across an SSD and balance erase count of each block, thereby extending flash lifetime.

3.5 Bad Blocks Management

Bad Blocks are blocks that contain one or more invalid bits whose reliability are not guaranteed. The Bad Blocks may be presented while the SSD is shipped, or may develop during the life time of the SSD. When the Bad Blocks is detected, it will be flagged, and not be used anymore. The SSD implement Bad Blocks management, Bad Blocks replacement, Error Correct Code to avoid data error occurred. The functions will be enabled automatically to transfer data from Bad Blocks to spare blocks, and correct error bit.

3.6 Power Cycling

Innodisk's power cycling management is a comprehensive data protection mechanism that functions before and after a sudden power outage to SSD. Low-power detection terminates data writing before an abnormal power-off, while table-remapping after power-on deletes corrupt data and maintains data integrity. Innodisk's power cycling provides effective power cycling management, preventing data stored in flash from degrading with use.

3.7 Garbage Collection

Garbage collection is used to maintain data consistency and perform continual data cleansing on SSDs. It runs as a background process, freeing up valuable controller resources while sorting good data into available blocks, and deleting bad blocks. It also significantly reduces write operations to the drive, thereby increasing the SSD's speed and lifespan.

3.8 End to End Data Path Protection

End-to-End Data Path Protection (ETEP) is a method that ensures the data integrity on every single step from the moment the data enters the SSD from the host until it leaves. ETEP safeguards the data through utilizing error correction code (ECC) at every data transfer point

3.9 Thermal Management

CFexpress 3ME2 has build-in thermal sensor which can detect environment temperature of SSD. In the meantime, firmware will monitor the thermal sensor to prevent any failure of overheating. During extreme temperature, firmware will adjust the data transfer behavior to maintain the SSD's reliable operation.

4. Installation Requirements

4.1 CFexpress 3ME2 Pin Directions

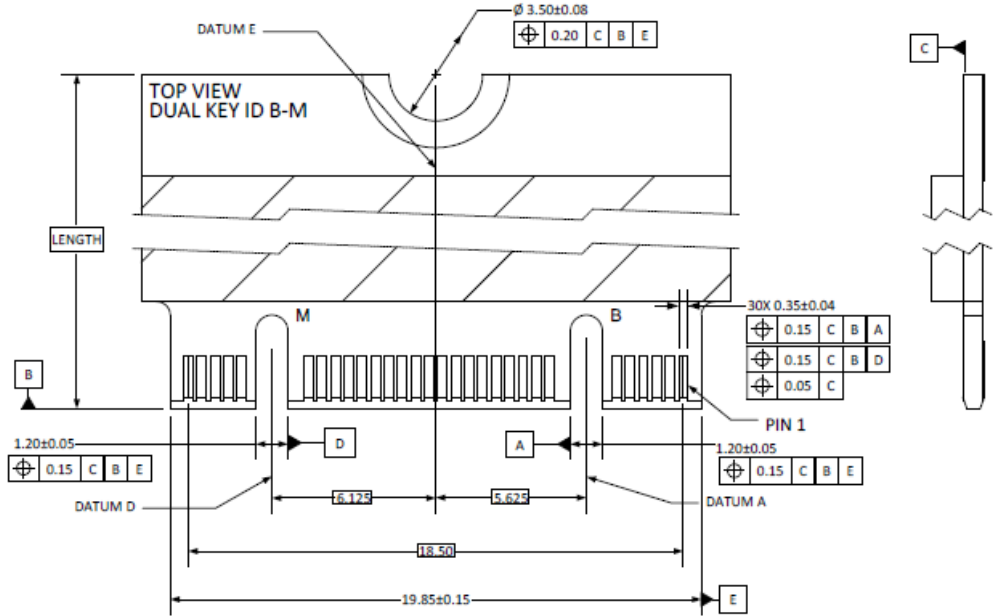

Figure 4: Signal Segment and Power Segment

4.2 Electrical Connections for CFexpress 3ME2

interconnect is based on a 75 position Edge Card connector. The 75 position connector is intended to be keyed so as to distinguish between families of host interfaces and the various Sockets used in general Platforms. CFexpress 3ME2 is compliant with Socket 2 key B-M.

4.3 Device Drive

CFexpress 3ME2 is compliant with NVMe 1.2. To make sure NVMe storage devices can work in your system, both operation system and BIOS can support NVMe. Most of OS includes NVMe in-box driver now. For more information about the NVMe driver support in each OS, please visit the website <http://nvmexpress.org/resources/drivers>. For BIOS NVMe driver support please contact with your motherboard manufacturers.

4.4 Write Protection (Optional)

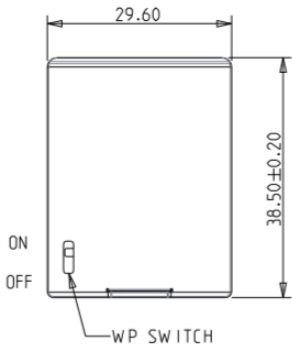

Figure 5: Write Protect Switch

Innodisk CFexpress 3ME2 within the write-protect function could prevent the device from modification and deletion. Write-protected data could only be read, that is, users could not write to it, edit it, append data to it, or delete it. When users would like to make sure that neither themselves nor others could modify or destroy the file, users could switch on write-protection. Thus, CFexpress 3ME2 could process write-protect mechanism and disable flash memory to be written-in any data. Only while the system power-off, users could switch on write-protection. Write-protection could not be switched-on, after OS booting.

5. SMART / Health Information

This log page is used to provide SMART and general health information. The information provided is over the life of the controller and is retained across power cycles. More details about Set Features command, please refer to NVM Express 1.2

5.1 Get Log Page(Log Identifier 02h)

Innodisk 3ME2 series SMART / Health Information Log are listed in following table.

Table 10: Get Log Page – SMART / Health Information Log

Bytes	Description														
0	<p>Critical Warning: This field indicates critical warnings for the state of the controller. Each bit corresponds to a critical warning type; multiple bits may be set. If a bit is cleared to '0', then that critical warning does not apply. Critical warnings may result in an asynchronous event notification to the host. Bits in this field represent the current associated state and are not persistent.</p> <table border="1"> <thead> <tr> <th>Bit</th> <th>Definition</th> </tr> </thead> <tbody> <tr> <td>00</td> <td>If set to '1', then the available spare space has fallen below the threshold.</td> </tr> <tr> <td>01</td> <td>If set to '1', then a temperature is above an over temperature threshold or below an under</td> </tr> <tr> <td>02</td> <td>If set to '1', then the NVM subsystem reliability has been degraded due to significant media related</td> </tr> <tr> <td>03</td> <td>If set to '1', then the media has been placed in read only mode.</td> </tr> <tr> <td>04</td> <td>If set to '1', then the volatile memory backup device has failed. This field is only valid if the</td> </tr> <tr> <td>07:05</td> <td>Reserved</td> </tr> </tbody> </table>	Bit	Definition	00	If set to '1', then the available spare space has fallen below the threshold.	01	If set to '1', then a temperature is above an over temperature threshold or below an under	02	If set to '1', then the NVM subsystem reliability has been degraded due to significant media related	03	If set to '1', then the media has been placed in read only mode.	04	If set to '1', then the volatile memory backup device has failed. This field is only valid if the	07:05	Reserved
Bit	Definition														
00	If set to '1', then the available spare space has fallen below the threshold.														
01	If set to '1', then a temperature is above an over temperature threshold or below an under														
02	If set to '1', then the NVM subsystem reliability has been degraded due to significant media related														
03	If set to '1', then the media has been placed in read only mode.														
04	If set to '1', then the volatile memory backup device has failed. This field is only valid if the														
07:05	Reserved														
2:1	<p>Composite Temperature: Contains a value corresponding to a temperature in degrees Kelvin that represents the current composite temperature of the controller and namespace(s) associated with that controller. The manner in which this value is computed is implementation specific and may not represent the actual temperature of any physical point in the NVM subsystem. The value of this field may be used to trigger an asynchronous event.</p>														

	Warning and critical overheating composite temperature threshold values are reported by the WCTEMP and CCTEMP fields in the Identify Controller data structure.
3	Available Spare: Contains a normalized percentage (0 to 100%) of the remaining spare capacity available.
4	Available Spare Threshold: When the Available Spare falls below the threshold indicated in this field, an asynchronous event completion may occur. The value is indicated as a normalized percentage (0 to 100%).
5	Percentage Used: Contains a vendor specific estimate of the percentage of NVM subsystem life used based on the actual usage and the manufacturer's prediction of NVM life. A value of 100 indicates that the estimated endurance of the NVM in the NVM subsystem has been consumed, but may not indicate an NVM subsystem failure. The value is allowed to exceed 100. Percentages greater than 254 shall be represented as 255. This value shall be updated once per power-on hour (when the controller is not in a sleep state). Refer to the JEDEC JESD218A standard for SSD device life and endurance measurement techniques.
31:6	Reserved
47:32	Data Units Read: Contains the number of 512 byte data units the host has read from the controller; this value does not include metadata. This value is reported in thousands (i.e., a value of 1 corresponds to 1000 units of 512 bytes read) and is rounded up. When the LBA size is a value other than 512 bytes, the controller shall convert the amount of data read to 512 byte units. For the NVM command set, logical blocks read as part of Compare and Read operations shall be included in this value.
63:48	Data Units Written: Contains the number of 512 byte data units the host has written to the controller; this value does not include metadata. This value is reported in thousands (i.e., a value of 1 corresponds to 1000 units of 512 bytes written) and is rounded up. When the LBA size is a value other than 512 bytes, the controller shall convert the amount of data written to 512 byte units. For the NVM command set, logical blocks written as part of Write operations shall be included in this value. Write Uncorrectable commands shall not impact this value.
79:64	Host Read Commands: Contains the number of read commands completed by the controller. For the NVM command set, this is the number of Compare and Read commands.

95:80	<p>Host Write Commands: Contains the number of write commands completed by the controller.</p> <p>For the NVM command set, this is the number of Write commands.</p>
111:96	<p>Controller Busy Time: Contains the amount of time the controller is busy with I/O commands. The controller is busy when there is a command outstanding to an I/O Queue (specifically, a command was issued via an I/O Submission Queue Tail doorbell write and the corresponding completion queue entry has not been posted yet to the associated I/O Completion Queue). This value is reported in minutes.</p>
127:112	<p>Power Cycles: Contains the number of power cycles.</p>
143:128	<p>Power On Hours: Contains the number of power-on hours. This may not include time that the controller was powered and in a non-operational power state.</p>
159:144	<p>Unsafe Shutdowns: Contains the number of unsafe shutdowns. This count is incremented when a shutdown notification (CC.SHN) is not received prior to loss of power.</p>
175:160	<p>Media and Data Integrity Errors: Contains the number of occurrences where the controller detected an unrecovered data integrity error. Errors such as uncorrectable ECC, CRC checksum failure, or LBA tag mismatch are included in this field.</p>
191:176	<p>Number of Error Information Log Entries: Contains the number of Error Information log entries over the life of the controller.</p>
195:192	<p>Warning Composite Temperature Time: Contains the amount of time in minutes that the controller is operational and the Composite Temperature is greater than or equal to the Warning Composite Temperature Threshold (WCTEMP) field and less than the Critical Composite Temperature Threshold (CCTEMP) field in the Identify Controller data structure.</p> <p>If the value of the WCTEMP or CCTEMP field is 0h, then this field is always cleared to 0h regardless of the Composite Temperature value.</p>
199:196	<p>Critical Composite Temperature Time: Contains the amount of time in minutes that the controller is operational and the Composite Temperature is greater than the Critical Composite Temperature Threshold (CCTEMP) field in the Identify Controller data structure.</p> <p>If the value of the CCTEMP field is 0h, then this field is always cleared to 0h regardless of the Composite Temperature value.</p>
201:200	<p>Temperature Sensor 1: Contains the current temperature reported by temperature sensor 1.</p>
203:202	<p>Temperature Sensor 2: Contains the current temperature reported by temperature sensor 2.</p>

205:204	Temperature Sensor 3: Contains the current temperature reported by temperature sensor 3.
207:206	Temperature Sensor 4: Contains the current temperature reported by temperature sensor 4.
209:208	Temperature Sensor 5: Contains the current temperature reported by temperature sensor 5.
211:210	Temperature Sensor 6: Contains the current temperature reported by temperature sensor 6.
213:212	Temperature Sensor 7: Contains the current temperature reported by temperature sensor 7.
215:214	Temperature Sensor 8: Contains the current temperature reported by temperature sensor 8.
511:216	Reserved

6. Part Number Rule

CODE	1	2	3	4	5	6	7	8	9	10	11	12	13	14	15	16	17	18	19	20	21
	D	E	C	F	X	-	6	4	G	M	6	1	B	C	A	Q	C	(W)	-	X	X
Definition																					
Code 1st (Disk)											Code 14th (Operation Temperature)										
D : Disk											C: Standard Grade (0°C ~ +70°C)										
Code 2nd (Feature set)											W: Industrial Grade (-40°C ~ +85°C)										
E : Embedded series																					
Code 3rd ~5th (Form factor)											Code 15th (Internal control)										
CFX: CFexpress(Type B)											A~Z: BGA PCB version.										
Code 7th ~9th (Capacity)											Code 16th (Channel of data transfer)										
32G: 32GB			64G: 64GB			A28: 128GB					D: Dual Channels										
B56:256GB											Q: Quad Channels										
Code 10th ~12th (Controller)											Code 17th (Flash Type)										
M61: Marvell 88NV1160											C: Toshiba MLC										
Code 13th (Flash mode)											Code 18th (Optional function)										
B: Toshiba 15nm											W: HW Write Protect										
											Code 19th ~21st (Customize code)										

7. Appendix

REACH



宜鼎國際股份有限公司
Innodisk Corporation
REACH Declaration

Tel:(02)7703-3000 Fax:(02) 7703-3555 Internet: <http://www.innodisk.com/>

We hereby confirm that the product(s) delivered to

Innodisk P/N	Description
All Innodisk EM FLASH Products	

- contain(s) no hazardous substances or constituents exceeding the defined threshold 0.1 % by weight in homogenous material if not otherwise specified, as described in the candidate list table currently including 201 substances and shown on the ECHA website (<http://echa.europa.eu/de/candidate-list-table>).
- contain(s) one or more hazardous substances or constituents exceeding 0.1 % by weight in homogenous material if not otherwise specified in candidate list table. Where the threshold value is exceeded, the substances in question are to be declared in accompanying Appendix A.
- Comply with REACH Annex XVII.

Guarantor

Company name 公司名稱：Innodisk Corporation 宜鼎國際股份有限公司

Company Representative 公司代表人：Randy Chien 簡川勝

Company Representative Title 公司代表人職稱：Chairman 董事長

Date 日期：2019 / 07 / 24

RoHS



宜鼎國際股份有限公司
Innodisk Corporation

Tel:(02)7703-3000 Fax:(02) 7703-3555 Internet: http://www.innodisk.com/

RoHS 自我宣告書 (RoHS Declaration of Conformity)

Manufacturer Product: All Innodisk EP products

一、宜鼎國際股份有限公司（以下稱本公司）特此保證售予貴公司之所有產品，皆符合歐盟 2011/65/EU 及 (EU) 2015/863 關於 RoHS 之規範要求。

Innodisk Corporation declares that all products sold to the company, are complied with European Union RoHS Directive (2011/65/EU) and (EU) 2015/863 requirement.

二、本公司同意因本保證書或與本保證書相關事宜有所爭議時，雙方宜友好協商，達成協議。

Innodisk Corporation agrees that both parties shall settle any dispute arising from or in connection with this Declaration of Conformity by friendly negotiations.

Name of hazardous substance	Limited of RoHS ppm (mg/kg)
鉛 (Pb)	< 1000 ppm
汞 (Hg)	< 1000 ppm
鎘 (Cd)	< 100 ppm
六價鉻 (Cr 6+)	< 1000 ppm
多溴聯苯 (PBBs)	< 1000 ppm
多溴二苯醚 (PBDEs)	< 1000 ppm
鄰苯二甲酸二(2-乙基己基)酯 (DEHP)	< 1000 ppm
鄰苯二甲酸丁酯苯甲酯 (BBP)	< 1000 ppm
鄰苯二甲酸二丁酯 (DBP)	< 1000 ppm
鄰苯二甲酸二異丁酯 (DIBP)	< 1000 ppm

立保證書人 (Guarantor)

Company name 公司名稱: Innodisk Corporation 宜鼎國際股份有限公司

Company Representative 公司代表人: Randy Chien 簡川勝

Company Representative Title 公司代表人職稱: Chairman 董事長

Date 日期: 2018 / 07 / 01



CE

