



Features

- mPCIe to 1 Movidius Myriad X
- Low Power Design
- Support Intel OpenVINO Toolkit
- Supported Framework: TensorFlow, Caffe, MXNET
- Complies with CE/FCC Class A
- 30μ" golden finger, 3-year warranty

Mechanical Drawing

With Heatsink

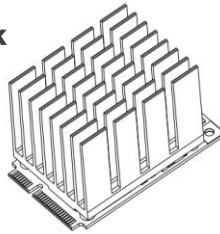

Without Heatsink

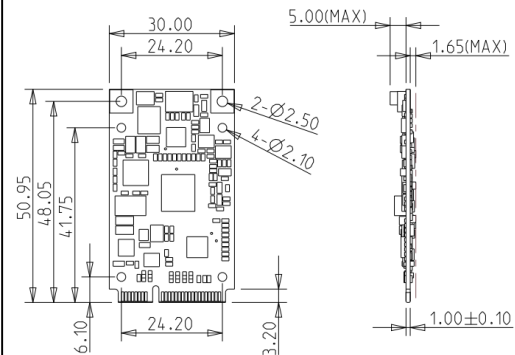
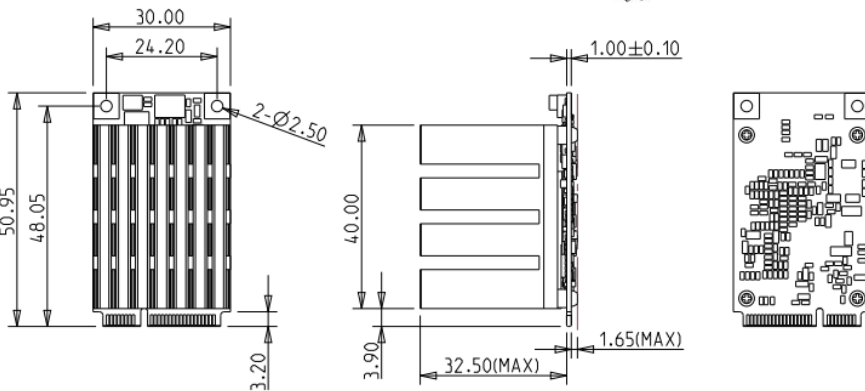
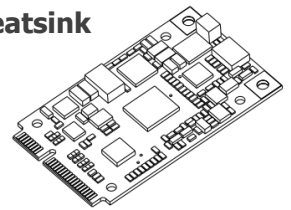

Headquarters (Taiwan)

5F., No. 237, Sec. 1, Datong Rd.,
Xizhi Dist., New Taipei City 221,
Taiwan
Tel: +886-2-7703-3000
Email: sales@innodisk.com

Branch Offices:

USA
usasales@innodisk.com
+1-510-770-9421

Europe
eusales@innodisk.com
+31-40-3045-400

Japan
jpsales@innodisk.com
+81-3-6667-0162

China
sales_cn@innodisk.com
+86-755-2167-3689

www.innodisk.com

© 2019 Innodisk Corporation.
All right reserved. Specifications
are subject to change without
prior notice.

December 12, 2019

Specifications

Form-Factor	mPCIe
Input I/F	PCI Express 2.0 x 1
TDP	4W
Dimension (WxLxH)	With Heatsink: 30 x 50.9 x 35.15 mm, Weight: 29.47g Without Heatsink: 30 x 50.9 x 7.65 mm, Weight: 6.25g
Temperature	Operation: 0°C ~ +60°C
Support Framework	TensorFlow, Caffe, MXNET
OS Support	Windows 10 64-bit Ubuntu 18.04, 64-bit
Notes	Please download OpenVINO Toolkit from Intel website: https://docs.openvino toolkit.org/latest/index.html