

# M.2 (P80)

## 3IE2 Series

**Customer:** \_\_\_\_\_

**Customer**

**Part**

**Number:** \_\_\_\_\_

**Innodisk**

**Part**

**Number:** \_\_\_\_\_

**Innodisk**

**Model Name:** \_\_\_\_\_

**Date:** \_\_\_\_\_

<b>Innodisk Approver</b>	<b>Customer Approver</b>

**Total Solution For  
Industrial Flash Storage**

## Table of contents

<b>LIST OF FIGURES .....</b>	<b>6</b>
<b>1. PRODUCT OVERVIEW .....</b>	<b>7</b>
<b>1.1 INTRODUCTION OF INNODISK M.2 (P80) 3IE2 .....</b>	<b>7</b>
<b>1.2 PRODUCT VIEW AND MODELS .....</b>	<b>7</b>
<b>1.3 PCIe INTERFACE .....</b>	<b>7</b>
<b>2. PRODUCT SPECIFICATIONS .....</b>	<b>8</b>
<b>2.1 CAPACITY AND DEVICE PARAMETERS.....</b>	<b>8</b>
<b>2.2 PERFORMANCE .....</b>	<b>8</b>
<b>2.3 ELECTRICAL SPECIFICATIONS .....</b>	<b>8</b>
<b>2.3.1 Power Requirement .....</b>	<b>8</b>
<b>2.3.2 Power Consumption .....</b>	<b>8</b>
<b>2.4 ENVIRONMENTAL SPECIFICATIONS .....</b>	<b>9</b>
<b>2.4.1 Temperature Ranges .....</b>	<b>9</b>
<b>2.4.2 Humidity.....</b>	<b>9</b>
<b>2.4.3 Shock and Vibration .....</b>	<b>9</b>
<b>2.4.4 Mean Time between Failures (MTBF) .....</b>	<b>9</b>
<b>2.5 CE AND FCC COMPATIBILITY .....</b>	<b>9</b>
<b>2.6 RoHS COMPLIANCE .....</b>	<b>10</b>
<b>2.7 RELIABILITY .....</b>	<b>10</b>
<b>2.8 TRANSFER MODE .....</b>	<b>10</b>
<b>2.9 PIN ASSIGNMENT .....</b>	<b>11</b>
<b>2.10 MECHANICAL DIMENSIONS.....</b>	<b>12</b>
<b>M.2 TYPE 2280-D2-B-M .....</b>	<b>12</b>
<b>2.11 ASSEMBLY WEIGHT .....</b>	<b>13</b>
<b>2.12 SEEK TIME .....</b>	<b>13</b>
<b>2.13 NAND FLASH MEMORY.....</b>	<b>13</b>
<b>3. THEORY OF OPERATION.....</b>	<b>14</b>
<b>3.1 OVERVIEW.....</b>	<b>14</b>
<b>3.2 PCIe GEN III X2 CONTROLLER.....</b>	<b>14</b>
<b>3.3 ERROR DETECTION AND CORRECTION.....</b>	<b>14</b>
<b>3.4 WEAR-LEVELING .....</b>	<b>15</b>
<b>3.5 BAD BLOCKS MANAGEMENT .....</b>	<b>15</b>
<b>3.6 POWER CYCLING .....</b>	<b>15</b>
<b>3.7 GARBAGE COLLECTION.....</b>	<b>15</b>
<b>3.8 END TO END DATA PATH PROTECTION .....</b>	<b>15</b>
<b>3.9 THERMAL MANAGEMENT .....</b>	<b>15</b>
<b>4. INSTALLATION REQUIREMENTS .....</b>	<b>16</b>

- 4.1 M.2 (P80) 3IE2 PIN DIRECTIONS ..... 16**
- 4.2 ELECTRICAL CONNECTIONS FOR M.2 (P80) 3IE2 ..... 16**
- 4.3 DEVICE DRIVE ..... 16**
- 5. SMART / HEALTH INFORMATION.....17**
  - 5.1 GET LOG PAGE(LOG IDENTIFIER 02H) ..... 17**
- 6. PART NUMBER RULE .....21**
- 7. APPENDIX .....22**

## REVISION HISTORY

Revision	Description	Date
Preliminary 1.0	First release	Oct., 2019
V1.0	Official release	Dec., 2019

## List of Tables

<b>TABLE 1: DEVICE PARAMETERS</b> .....	8
<b>TABLE 2: PERFORMANCE</b> .....	8
<b>TABLE 3: INNODISK M.2 (P80) 3IE2 POWER REQUIREMENT</b> .....	8
<b>TABLE 4: POWER CONSUMPTION</b> .....	9
<b>TABLE 5: TEMPERATURE RANGE FOR M.2 (P80) 3IE2</b> .....	9
<b>TABLE 6: SHOCK/VIBRATION TESTING FOR M.2 (P80) 3IE2</b> .....	9
<b>TABLE 7: M.2 (P80) 3IE2 MTBF</b> .....	9
<b>TABLE 8: M.2 (P80) 3IE2 TBW</b> .....	10
<b>TABLE 9: INNODISK M.2 (P80) 3IE2 PIN ASSIGNMENT</b> .....	11
<b>TABLE 10: GET LOG PAGE – SMART / HEALTH INFORMATION LOG</b> .....	17

## List of Figures

<b>FIGURE 1: INNODISK M.2 (P80) 3IE2 (TYPE 2280)</b> .....	7
<b>FIGURE 2: INNODISK M.2 (P80) 3IE2 DIAGRAM</b> .....	12
<b>FIGURE 3: INNODISK M.2 (P80) 3IE2 BLOCK DIAGRAM</b> .....	14
<b>FIGURE 4: SIGNAL SEGMENT AND POWER SEGMENT</b> .....	16

# 1. Product Overview

## 1.1 Introduction of Innodisk M.2 (P80) 3IE2

Innodisk M.2 (P80) 3IE2 is an NVM Express DRAM-less SSD designed as the standard M.2 2280 form factor with PCIe interface. M.2 (P80)3IE2 supports PCIe Gen III x2, and it is compliant with NVMe 1.2 providing excellent performance. In addition, iSLC technology improves the performance, through the use of flash management algorithms, iSLC improves SSD endurance up to 20,000 times, increasing lifespans up to 6 times longer than MLC-based solutions.

Innodisk M.2 (P80) 3IE2 is integrated with Marvell controller which provide both low power consumption and efficient heat dissipation, making the SSD optimal for space-constrained IPCs and server boot-up applications.

**CAUTION** *TRIM must be enabled.*

*TRIM enables SSD's controller to skip invalid data instead of moving. It can free up significant amount of resources, extends the lifespan of SSD by reducing erase, and write cycles on the SSD. Innodisk's handling of garbage collection along with TRIM command improves write performance on SSDs.*

## 1.2 Product View and Models

Innodisk M.2 (P80) 3IE2 is available in follow capacities within MLC flash ICs.

M.2 (P80) 3IE2 32GB

M.2 (P80) 3IE2 64GB

M.2 (P80) 3IE2 128GB

M.2 (P80) 3IE2 256GB

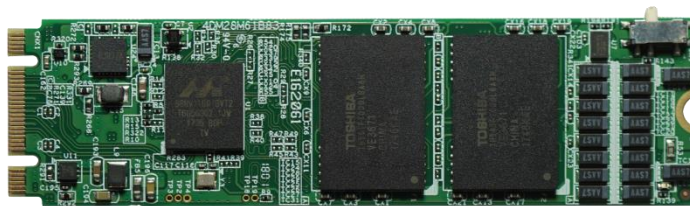

**Figure 1: Innodisk M.2 (P80) 3IE2 (type 2280)**

## 1.3 PCIe Interface

Innodisk M.2 (P80) 3IE2 supports PCIe Gen III interface and compliant with NVMe 1.2. M.2 (P80) 3IE2 can work under PCIe Gen 1, Gen 2 and Gen 3.

Most of operating system includes NVMe in-box driver now. For more information about the driver support in each OS, please visit <http://nvmexpress.org/resources/drivers>.

## 2. Product Specifications

### 2.1 Capacity and Device Parameters

M.2 (P80) 3IE2 device parameters are shown in Table 1.

**Table 1: Device parameters**

Capacity	LBA	User Capacity(MB)
32GB	62533296	30,533
64GB	125045424	61,057
128GB	250069680	122,104
256GB	500118192	244,198

### 2.2 Performance

Burst Transfer Rate: 16.0Gbps

**Table 2: Performance**

Capacity	32GB	64GB	128GB	256GB
Sequential* Read (max.)	1000MB/s	1350 MB/s	1350 MB/s	1350 MB/s
Sequential* Write (max.)	300MB/s	580 MB/s	700 MB/s	700 MB/s
4KB Random* Read (QD32)	34000	51000	51000	51000
4KB Random* Write (QD32)	43000	61000	64000	64000

Note: \* Performance is based on CrystalDiskMark 6.0.2 with file size 1000MB of Queue Depth 32

### 2.3 Electrical Specifications

#### 2.3.1 Power Requirement

**Table 3: Innodisk M.2 (P80) 3IE2 Power Requirement**

Item	Symbol	Rating	Unit
Input voltage	V <sub>IN</sub>	+3.3 DC +- 5%	V

#### 2.3.2 Power Consumption



**Table 4: Power Consumption**

Mode	Power Consumption (mA)
Read	871 (rms.)
Write	803 (rms.)
Idle	407 (rms.)

\* Target: 256GB M.2 (P80) 3IE2

## 2.4 Environmental Specifications

### 2.4.1 Temperature Ranges

**Table 5: Temperature range for M.2 (P80) 3IE2**

Temperature	Range
Operating	Standard Grade: 0°C to +70°C
	Industrial Grade: -40°C to +85°C
Storage	-55°C to +95°C

### 2.4.2 Humidity

Relative Humidity: 10-95%, non-condensing

### 2.4.3 Shock and Vibration

**Table 6: Shock/Vibration Testing for M.2 (P80) 3IE2**

Reliability	Test Conditions	Reference Standards
Vibration	7 Hz to 2K Hz, 20G, 3 axes	IEC 60068-2-6
Mechanical Shock	Duration: 0.5ms, 1500 G, 3 axes	IEC 60068-2-27

### 2.4.4 Mean Time between Failures (MTBF)

Table 7 summarizes the MTBF prediction results for various M.2 (P80) 3IE2 configurations. The analysis was performed using a RAM Commander™ failure rate prediction.

- **Failure Rate:** The total number of failures within an item population, divided by the total number of life units expended by that population, during a particular measurement interval under stated condition.
- **Mean Time between Failures (MTBF):** A basic measure of reliability for repairable items: The mean number of life units during which all parts of the item perform within their specified limits, during a particular measurement interval under stated conditions.

**Table 7: M.2 (P80) 3IE2 MTBF**

Product	Condition	MTBF (Hours)
Innodisk M.2 (P80) 3IE2	Telcordia SR-332 GB, 25°C	>3,000,000

## 2.5 CE and FCC Compatibility

M.2 (P80) 3IE2 conforms to CE and FCC requirements.

## 2.6 RoHS Compliance

M.2 (P80) 3IE2 is fully compliant with RoHS directive.

## 2.7 Reliability

**Table 8: M.2 (P80) 3IE2 TBW**

Parameter		Value
Read Cycles		Unlimited Read Cycles
Flash endurance		20,000 P/E cycles
Wear-Leveling Algorithm		Support
Bad Blocks Management		Support
Error Correct Code		Support(LDPC)
<b>TBW* (Total Bytes Written) Unit: TB</b>		
Capacity	Sequential workload	Client workload
32GB	687.4	312.5
64GB	1374.8	625
128GB	2749.6	1250
256GB	5449.2	2500
* Note:		
<ol style="list-style-type: none"> <li>1. Sequential: Mainly sequential write, tested by Vdbench.</li> <li>2. Client: Follow JESD218 Test method and JESD219A Workload, tested by ULINK. (The capacity lower than 64GB client workload is not specified in JEDEC219A, the values are estimated.)</li> <li>3. Based on out-of-box performance.</li> </ol>		

## 2.8 Transfer Mode

M.2 (P80) 3IE2 support following transfer mode:

PCIe Gen III 8Gbps

PCIe Gen II 4Gbps

PCIe Gen I 2Gbps

## 2.9 Pin Assignment

Innodisk M.2 (P80) 3IE2 follows standard M.2 spec, socket 2 key B-M PCIe-based SSD pinout. See Table 9 for M.2 (P80) 3IE2 pin assignment.

**Table 9: Innodisk M.2 (P80) 3IE2 Pin Assignment**

Signal Name	Pin #	Pin #	Signal Name
		75	GND
3.3V	74	73	GND
3.3V	72	71	GND
3.3V	70	69	NC
NC	68	67	NC
Notch	66	65	Notch
Notch	64	63	Notch
Notch	62	61	Notch
Notch	60	59	Notch
NC (Reserved)	58		
NC (Reserved)	56	57	GND
NC	54	55	REFCLKp
CLKREQ# (I/O)(0/3.3V)	52	53	REFCLKn
PERST# (I)(0/3.3V)	50	51	GND
NC	48	49	PERp0
NC	46	47	PERn0
NC	44	45	GND
SMB_DATA (I/O)(0/1.8V)	42	43	PETp0
SMB_CLK (I/O)(0/1.8V)	40	41	PETn0
NC	38	39	GND
NC	36	37	PERp1
NC	34	35	PERn1
NC	32	33	GND
NC	30	31	PETp1
NC	28	29	PETn1
NC	26	27	GND
NC	24	25	NC
NC	22	23	NC
NC	20	21	GND
Notch	18	19	Notch
Notch	16	17	Notch
Notch	14	15	Notch
Notch	12	13	Notch
NC	10	11	NC
NC	8	9	GND
NC	6	7	NC
3.3V	4	5	NC
3.3V	2	3	GND
		1	GND

## 2.10 Mechanical Dimensions

M.2 Type 2280-D2-B-M

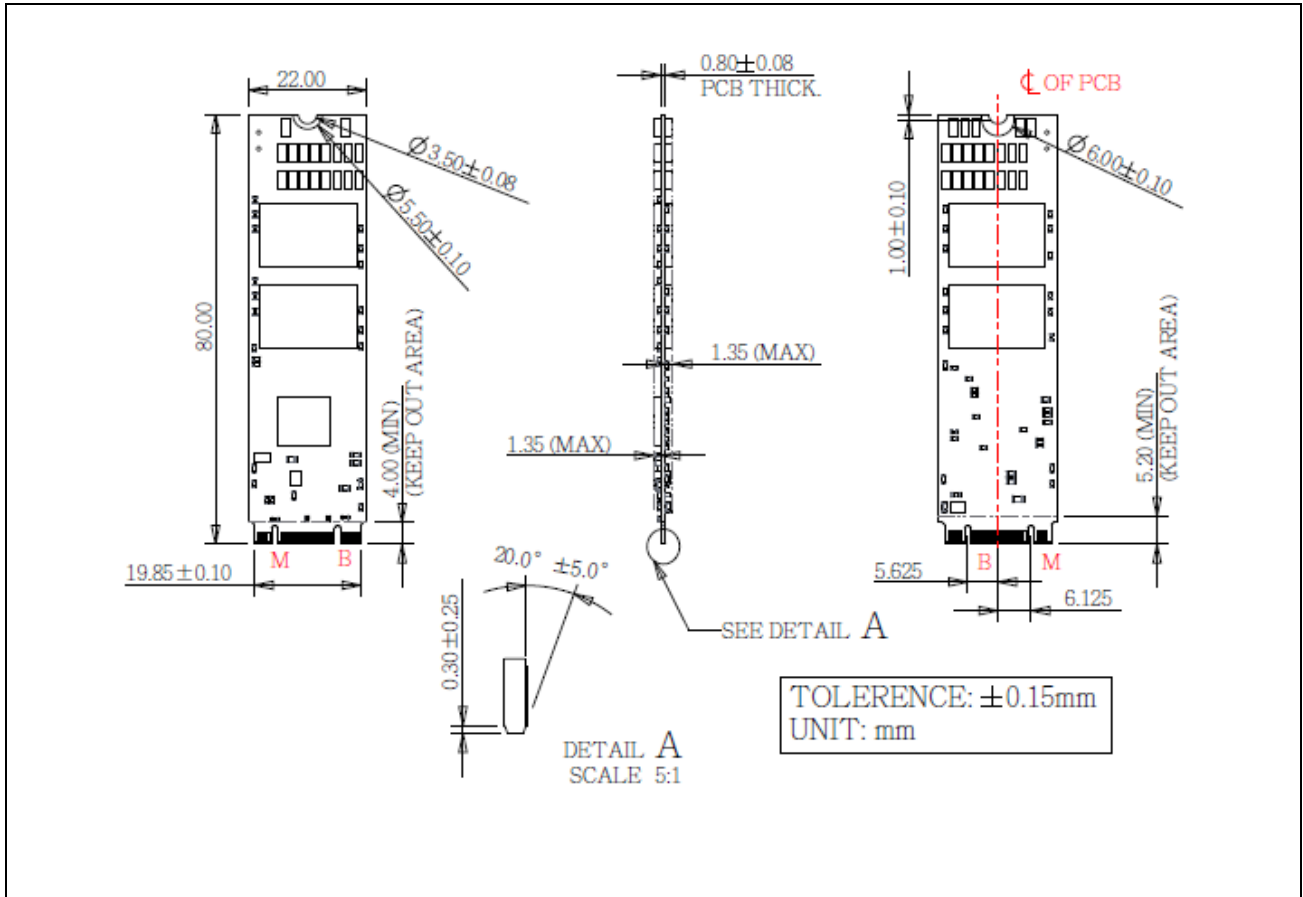

**Figure 2: Innodisk M.2 (P80) 3IE2 diagram**

**\*iCell is optional**

## **2.11 Assembly Weight**

An Innodisk M.2 (P80) 3IE2 within NAND flash ICs, 64GB's weight is 10 grams approximately.

## **2.12 Seek Time**

Innodisk M.2 (P80) 3IE2 is not a magnetic rotating design. There is no seek or rotational latency required.

## **2.13 NAND Flash Memory**

Innodisk M.2 (P80) 3IE2 uses Multi Level Cell (MLC) NAND flash memory, which is non-volatility, high reliability and high speed memory storage.

# 3. Theory of Operation

## 3.1 Overview

Figure 2 shows the operation of Innodisk M.2 (P80) 3IE2 from the system level, including the major hardware blocks.

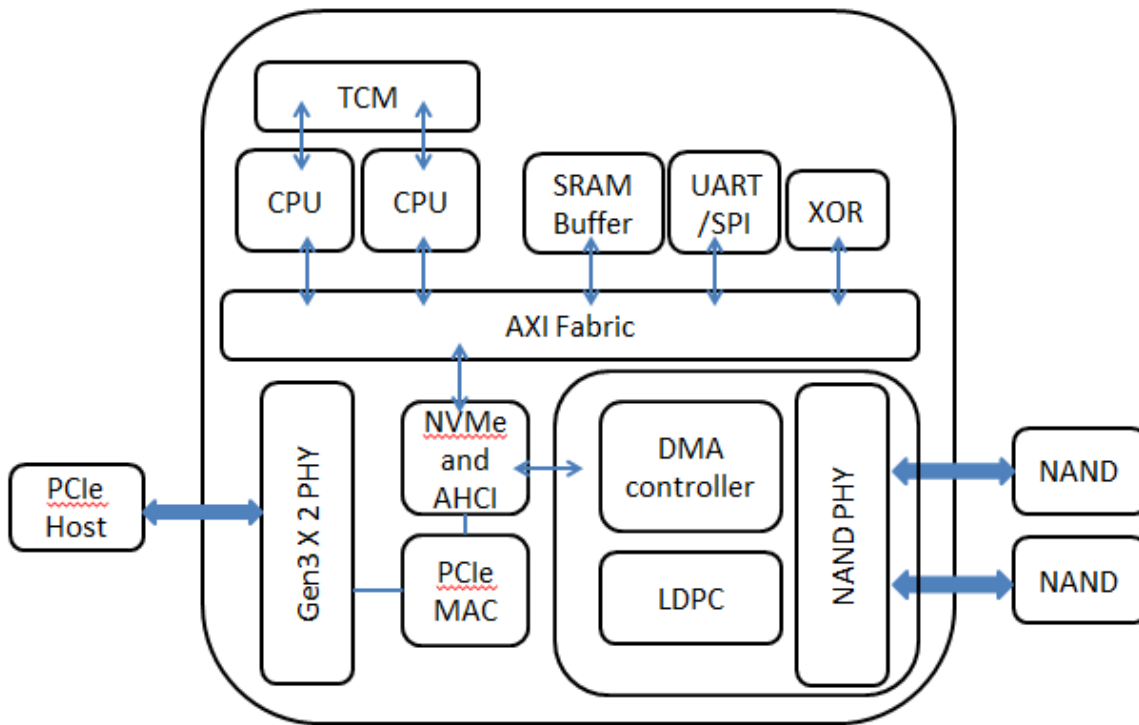

**Figure 3: Innodisk M.2 (P80) 3IE2 Block Diagram**

Innodisk M.2 (P80) 3IE2 integrates a PCIe Gen III x2 controller and NAND flash memories. Communication with the host occurs through the host interface, using the standard NVM protocol. Communication with the flash device(s) occurs through the flash interface.

## 3.2 PCIe Gen III x2 Controller

Innodisk M.2 (P80) 3IE2 is designed with 88NV1160, a PCIe Gen IIIx2 controller is compliant with NVMe 1.2, up to 16.0Gbps transfer speed. Also it is compliant with PCIe Gen 1, Gen 2 and Gen 3 specification. The controller supports up to 4 channels for flash interface.

## 3.3 Error Detection and Correction

Innodisk M.2 (P80) 3IE2 is designed with hardware LDPC ECC engine with hard-decision and soft-decision decoding. Low-density parity-check (LDPC) codes have excellent error correcting performance close to the Shannon limit when decoded with the belief-propagation (BP) algorithm using soft-decision information.

### 3.4 Wear-Leveling

Flash memory can be erased within a limited number of times. This number is called the **erase cycle limit** or **write endurance limit** and is defined by the flash array vendor. The erase cycle limit applies to each individual erase block in the flash device.

Innodisk M.2 (P80) 3IE2 uses a combination of two types of wear leveling- dynamic and static wear leveling- to distribute write cycling across an SSD and balance erase count of each block, thereby extending flash lifetime.

### 3.5 Bad Blocks Management

Bad Blocks are blocks that contain one or more invalid bits whose reliability are not guaranteed. The Bad Blocks may be presented while the SSD is shipped, or may develop during the life time of the SSD. When the Bad Blocks is detected, it will be flagged, and not be used anymore. The SSD implement Bad Blocks management, Bad Blocks replacement, Error Correct Code to avoid data error occurred. The functions will be enabled automatically to transfer data from Bad Blocks to spare blocks, and correct error bit.

### 3.6 Power Cycling

Innodisk's power cycling management is a comprehensive data protection mechanism that functions before and after a sudden power outage to SSD. Low-power detection terminates data writing before an abnormal power-off, while table-remapping after power-on deletes corrupt data and maintains data integrity. Innodisk's power cycling provides effective power cycling management, preventing data stored in flash from degrading with use.

### 3.7 Garbage Collection

Garbage collection is used to maintain data consistency and perform continual data cleansing on SSDs. It runs as a background process, freeing up valuable controller resources while sorting good data into available blocks, and deleting bad blocks. It also significantly reduces write operations to the drive, thereby increasing the SSD's speed and lifespan.

### 3.8 End to End Data Path Protection

End-to-end Data Path Protection that secures the data transmission between host system and NAND Flash. In the transmission path, no matter in or out, all buffer and storage implement Error Code Correction that optimizes the data integrity in the whole transmission of SSD.

### 3.9 Thermal Management

M.2 (P80) 3IE2 has build-in thermal sensor which can detect environment temperature of SSD. In the meantime, firmware will monitor the thermal sensor to prevent any failure of overheating. During extreme temperature, firmware will adjust the data transfer behavior to maintain the SSD's reliable operation.

# 4. Installation Requirements

## 4.1 M.2 (P80) 3IE2 Pin Directions

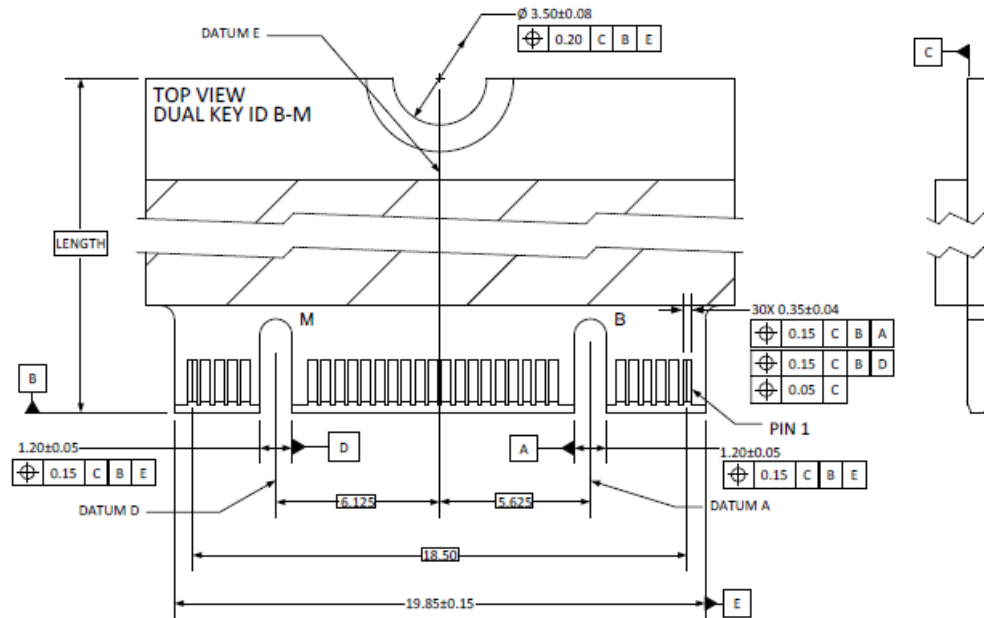

**Figure 4: Signal Segment and Power Segment**

## 4.2 Electrical Connections for M.2 (P80) 3IE2

M.2 interconnect is based on a 75 position Edge Card connector. The 75 position connector is intended to be keyed so as to distinguish between families of host interfaces and the various Sockets used in general Platforms. M.2(P80) 3IE2 is compliant with M.2 Socket 2 key B-M.

## 4.3 Device Drive

M.2(P42) 3IE2 is compliant with NVMe 1.2. Both Operation System and BIOS should include NVMe driver to compatible with NVMe device. Nowadays, most of OS includes NVMe in-box driver now. For more information about the driver support in each OS, please visit the website <http://nvmexpress.org/resources/drivers>. For BIOS NVMe driver support please contact with motherboard manufacturers.



## 5. SMART / Health Information

This log page is used to provide SMART and general health information. The information provided is over the life of the controller and is retained across power cycles. More details about Set Features command; please refer to NVM Express 1.2

### 5.1 Get Log Page(Log Identifier 02h)

Innodisk 3IE2 series SMART / Health Information Log are listed in following table.

**Table 10: Get Log Page – SMART / Health Information Log**

Bytes	Description														
0	<p><b>Critical Warning:</b> This field indicates critical warnings for the state of the controller. Each bit corresponds to a critical warning type; multiple bits may be set. If a bit is cleared to '0', then that critical warning does not apply. Critical warnings may result in an asynchronous event notification to the host. Bits in this field represent the current associated state and are not persistent.</p> <table border="1"> <thead> <tr> <th>Bit</th> <th>Definition</th> </tr> </thead> <tbody> <tr> <td>00</td> <td>If set to '1', then the available spare space has fallen below the threshold.</td> </tr> <tr> <td>01</td> <td>If set to '1', then a temperature is above an over temperature threshold or below an under</td> </tr> <tr> <td>02</td> <td>If set to '1', then the NVM subsystem reliability has been degraded due to significant media related</td> </tr> <tr> <td>03</td> <td>If set to '1', then the media has been placed in read only mode.</td> </tr> <tr> <td>04</td> <td>If set to '1', then the volatile memory backup device has failed. This field is only valid if the</td> </tr> <tr> <td>07:05</td> <td>Reserved</td> </tr> </tbody> </table>	Bit	Definition	00	If set to '1', then the available spare space has fallen below the threshold.	01	If set to '1', then a temperature is above an over temperature threshold or below an under	02	If set to '1', then the NVM subsystem reliability has been degraded due to significant media related	03	If set to '1', then the media has been placed in read only mode.	04	If set to '1', then the volatile memory backup device has failed. This field is only valid if the	07:05	Reserved
Bit	Definition														
00	If set to '1', then the available spare space has fallen below the threshold.														
01	If set to '1', then a temperature is above an over temperature threshold or below an under														
02	If set to '1', then the NVM subsystem reliability has been degraded due to significant media related														
03	If set to '1', then the media has been placed in read only mode.														
04	If set to '1', then the volatile memory backup device has failed. This field is only valid if the														
07:05	Reserved														
2:1	<p><b>Composite Temperature:</b> Contains a value corresponding to a temperature in degrees Kelvin that represents the current composite temperature of the controller and namespace(s) associated with that controller. The manner in which this value is computed is implementation specific and may not represent the actual temperature of any physical point in the NVM subsystem. The value of this field may be used to trigger an asynchronous event.</p>														

	Warning and critical overheating composite temperature threshold values are reported by the WCTEMP and CCTEMP fields in the Identify Controller data structure.
3	<b>Available Spare:</b> Contains a normalized percentage (0 to 100%) of the remaining spare capacity available.
4	<b>Available Spare Threshold:</b> When the Available Spare falls below the threshold indicated in this field, an asynchronous event completion may occur. The value is indicated as a normalized percentage (0 to 100%).
5	<b>Percentage Used:</b> Contains a vendor specific estimate of the percentage of NVM subsystem life used based on the actual usage and the manufacturer's prediction of NVM life. A value of 100 indicates that the estimated endurance of the NVM in the NVM subsystem has been consumed, but may not indicate an NVM subsystem failure. The value is allowed to exceed 100. Percentages greater than 254 shall be represented as 255. This value shall be updated once per power-on hour (when the controller is not in a sleep state).  Refer to the JEDEC JESD218A standard for SSD device life and endurance measurement techniques.
31:6	<b>Reserved</b>
47:32	<b>Data Units Read:</b> Contains the number of 512 byte data units the host has read from the controller; this value does not include metadata. This value is reported in thousands (i.e., a value of 1 corresponds to 1000 units of 512 bytes read) and is rounded up. When the LBA size is a value other than 512 bytes, the controller shall convert the amount of data read to 512 byte units.  For the NVM command set, logical blocks read as part of Compare and Read operations shall be included in this value.
63:48	<b>Data Units Written:</b> Contains the number of 512 byte data units the host has written to the controller; this value does not include metadata. This value is reported in thousands (i.e., a value of 1 corresponds to 1000 units of 512 bytes written) and is rounded up. When the LBA size is a value other than 512 bytes, the controller shall convert the amount of data written to 512 byte units.  For the NVM command set, logical blocks written as part of Write operations shall be included in this value. Write Uncorrectable commands shall not impact this value.
79:64	<b>Host Read Commands:</b> Contains the number of read commands completed by the controller.  For the NVM command set, this is the number of Compare and Read commands.

95:80	<p><b>Host Write Commands:</b> Contains the number of write commands completed by the controller.</p> <p>For the NVM command set, this is the number of Write commands.</p>
111:96	<p><b>Controller Busy Time:</b> Contains the amount of time the controller is busy with I/O commands. The controller is busy when there is a command outstanding to an I/O Queue (specifically, a command was issued via an I/O Submission Queue Tail doorbell write and the corresponding completion queue entry has not been posted yet to the associated I/O Completion Queue). This value is reported in minutes.</p>
127:112	<p><b>Power Cycles:</b> Contains the number of power cycles.</p>
143:128	<p><b>Power On Hours:</b> Contains the number of power-on hours. This may not include time that the controller was powered and in a non-operational power state.</p>
159:144	<p><b>Unsafe Shutdowns:</b> Contains the number of unsafe shutdowns. This count is incremented when a shutdown notification (CC.SHN) is not received prior to loss of power.</p>
175:160	<p><b>Media and Data Integrity Errors:</b> Contains the number of occurrences where the controller detected an unrecovered data integrity error. Errors such as uncorrectable ECC, CRC checksum failure, or LBA tag mismatch are included in this field.</p>
191:176	<p><b>Number of Error Information Log Entries:</b> Contains the number of Error Information log entries over the life of the controller.</p>
195:192	<p><b>Warning Composite Temperature Time:</b> Contains the amount of time in minutes that the controller is operational and the Composite Temperature is greater than or equal to the Warning Composite Temperature Threshold (WCTEMP) field and less than the Critical Composite Temperature Threshold (CCTEMP) field in the Identify Controller data structure.</p> <p>If the value of the WCTEMP or CCTEMP field is 0h, then this field is always cleared to 0h regardless of the Composite Temperature value.</p>
199:196	<p><b>Critical Composite Temperature Time:</b> Contains the amount of time in minutes that the controller is operational and the Composite Temperature is greater than the Critical Composite Temperature Threshold (CCTEMP) field in the Identify Controller data structure.</p> <p>If the value of the CCTEMP field is 0h, then this field is always cleared to 0h regardless of the Composite Temperature value.</p>
201:200	<p><b>Temperature Sensor 1:</b> Contains the current temperature reported by temperature sensor 1.</p>
203:202	<p><b>Temperature Sensor 2:</b> Contains the current temperature reported by temperature sensor 2.</p>

205:204	<b>Temperature Sensor 3:</b> Contains the current temperature reported by temperature sensor 3.
207:206	<b>Temperature Sensor 4:</b> Contains the current temperature reported by temperature sensor 4.
209:208	<b>Temperature Sensor 5:</b> Contains the current temperature reported by temperature sensor 5.
211:210	<b>Temperature Sensor 6:</b> Contains the current temperature reported by temperature sensor 6.
213:212	<b>Temperature Sensor 7:</b> Contains the current temperature reported by temperature sensor 7.
215:214	<b>Temperature Sensor 8:</b> Contains the current temperature reported by temperature sensor 8.
511:216	<b>Reserved</b>

## 6. Part Number Rule

CODE	1	2	3	4	5	6	7	8	9	10	11	12	13	14	15	16	17	18	19	20	21
	D	H	M	2	8	-	6	4	G	M	6	1	B	C	A	Q	C	(P)	-	X	X
<b>Definition</b>																					
<b>Code 1<sup>st</sup> (Disk)</b>											<b>Code 14<sup>th</sup> (Operation Temperature)</b>										
D : Disk											C: Standard Grade (0°C ~ +70°C)										
<b>Code 2<sup>nd</sup> (Feature set)</b>											W: Industrial Grade (-40°C ~ +85°C)										
H : iSLC																					
<b>Code 3<sup>rd</sup> ~5<sup>th</sup> (Form factor)</b>											<b>Code 15<sup>th</sup> (Internal control)</b>										
M28: M.2 Type 2280-D2-B-M											A~Z: BGA PCB version.										
<b>Code 7<sup>th</sup> ~9<sup>th</sup> (Capacity)</b>											<b>Code 16<sup>th</sup> (Channel of data transfer)</b>										
32G: 32GB			64G: 64GB			A28: 128GB					D: Dual Channels										
B56:256GB			B56:256GB								Q: Quad Channels										
<b>Code 10<sup>th</sup> ~12<sup>th</sup> (Controller)</b>											<b>Code 17<sup>th</sup> (Flash Type)</b>										
M61: Marvell 88NV1160											C: Toshiba MLC										
<b>Code 13<sup>th</sup> (Flash mode)</b>											<b>Code 18<sup>th</sup>(iCell)</b>										
B: Toshiba 15nm											P: optional function reserved for iCell										
											<b>Code 19<sup>th</sup> ~21<sup>st</sup> (Customize code)</b>										

# 7. Appendix

## REACH



### 宜鼎國際股份有限公司 Innodisk Corporation REACH Declaration

Tel:(02)7703-3000 Fax:(02) 7703-3555 Internet: <http://www.innodisk.com/>

We hereby confirm that the product(s) delivered to

Innodisk P/N	Description
All Innodisk EM FLASH Products	

- contain(s) no hazardous substances or constituents exceeding the defined threshold 0.1 % by weight in homogenous material if not otherwise specified, as described in the candidate list table currently including 197 substances and shown on the ECHA website (<http://echa.europa.eu/de/candidate-list-table>).
- contain(s) one or more hazardous substances or constituents exceeding 0.1 % by weight in homogenous material if not otherwise specified in candidate list table. Where the threshold value is exceeded, the substances in question are to be declared in accompanying Appendix A.
- Comply with REACH Annex XVII.

#### Guarantor

Company name 公司名稱：Innodisk Corporation 宜鼎國際股份有限公司

Company Representative 公司代表人：Randy Chien 簡川勝

Company Representative Title 公司代表人職稱：Chairman 董事長

Date 日期：2019 / 01 / 31



**RoHS**



**宜鼎國際股份有限公司  
Innodisk Corporation**

Page 1/1

Tel:(02)7703-3000 Fax:(02) 7703-3555 Internet: <http://www.innodisk.com/>

**RoHS 自我宣告書 (RoHS Declaration of Conformity)**

**Manufacturer Product: All Innodisk EM Flash and Dram products**

- 一、 宜鼎國際股份有限公司 (以下稱本公司) 特此保證售予貴公司之所有產品, 皆符合歐盟 2011/65/EU 及 (EU) 2015/863 關於 RoHS 之規範要求。  
Innodisk Corporation declares that all products sold to the company, are complied with European Union RoHS Directive (2011/65/EU) and (EU) 2015/863 requirement.
- 二、 本公司同意因本保證書或與本保證書相關事宜有所爭議時, 雙方宜友好協商, 達成協議。  
Innodisk Corporation agrees that both parties shall settle any dispute arising from or in connection with this Declaration of Conformity by friendly negotiations.

Name of hazardous substance	Limited of RoHS ppm (mg/kg)
鉛 (Pb)	< 1000 ppm
汞 (Hg)	< 1000 ppm
鎘 (Cd)	< 100 ppm
六價鉻 (Cr 6+)	< 1000 ppm
多溴聯苯 (PBBs)	< 1000 ppm
多溴二苯醚 (PBDEs)	< 1000 ppm
鄰苯二甲酸二(2-乙基己基)酯 (DEHP)	< 1000 ppm
鄰苯二甲酸丁酯苯甲酯 (BBP)	< 1000 ppm
鄰苯二甲酸二丁酯 (DBP)	< 1000 ppm
鄰苯二甲酸二異丁酯 (DIBP)	< 1000 ppm

**立 保 證 書 人 (Guarantor)**

Company name 公司名稱: Innodisk Corporation 宜鼎國際股份有限公司

Company Representative 公司代表人: Randy Chien 顏川勝

Company Representative Title 公司代表人職稱: Chairman 董事長

Date 日期: 2017 / 01 / 18



CE

International Standards Laboratory Corp. http://www.isl.com.tw

# Certificate

Issue Date: December 12, 2018  
Ref. Report No. ISL-18HE286CE

Product Name : M.2 (P80)  
Model(s) : M.2 (P80) 3\$\*#-&  
(\$:Flash type: (S:SLC, I:iSLC, M:MLC, T:3D TLC, A~Z:Others)  
\*:Product line: (E:Embedded, G:EverGreen, R:InnoRobust, S:Server, V:InnoREC, A~Z:Others)  
#:Product Generation: (empty, 0~9)  
&:Product line: (empty, P:Plus))

Brand : INNODISK  
Responsible Party : INNODISK CORPORATION  
Address : 3F-7., No. 237, Sec. 1, Datong Rd., Xizhi Dist., New Taipei City 221, Taiwan

We, International Standards Laboratory Corp., hereby certify that:

The sample ISL received which bearing the trade name and model specified above has been shown to comply with the applicable technical standards as indicated in the measurement report and was tested in accordance with the measurement procedures specified in European Council Directive EMC Directive 2014/30/EU. And Our laboratories is the accredited laboratories and are approved according to ISO/IEC 17025. The device was passed the test performed according to :

## CE

**Standards:**  
EN 55032:2015+AC:2016, CISPR 32: 2015+COR1:2016: Class B  
AS/NZS CISPR 32:2015: Class B  
EN 61000-3-2:2014 and IEC 61000-3-2:2014  
EN 61000-3-3: 2013 and IEC 61000-3-3: 2013  
EN 55024: 2010+A1:2015 and CISPR 24: 2010+A1:2015  
EN 61000-4-2: 2009 and IEC 61000-4-2: 2008  
EN 61000-4-3: 2006+A1: 2008 +A2: 2010 and IEC 61000-4-3:2006+A1: 2007+A2: 2010  
EN 61000-4-4:2012 and IEC 61000-4-4:2012  
EN 61000-4-5: 2014+A1:2017 and IEC 61000-4-5: 2014+A1:2017  
EN 61000-4-6:2014+AC:2015 and IEC 61000-4-6:2013  
EN 61000-4-8: 2010 and IEC 61000-4-8: 2009  
EN 61000-4-11: 2004+A1:2017 and IEC 61000-4-11: 2004+A1:2017

I attest to the accuracy of data and all measurements reported herein were performed by me or were made under my supervision and are correct to the best of my knowledge and belief. I assume full responsibility for the completeness of these measurements and vouch for the qualifications of all persons taking them.

*Bert Chen*  
Bert Chen / Director

  International Standards Laboratory Corp.  
 LT LAB:  
No. 120, Lane 180, Hsin Ho Rd., Lung-Tan Dist., Tao Yuan City 325, Taiwan  
Tel: 886-3-407-1718; Fax: 886-3-407-1738



FCC

ISL International Standards Laboratory Corp. http://www.isl.com.tw

# Certificate

Issue Date: December 12, 2018  
Ref. Report No. ISL-18HE286FB

Product Name : M.2 (P80)  
 Model(s) : M.2 (P80) 3\$\*#-&  
 (\$:Flash type: (S:SLC, I:iSLC, M:MLC, T:3D TLC, A~Z:Others)  
 \*:Product line: (E:Embedded, G:EverGreen, R:InnoRobust, S:Server, V:InnoREC, A~Z:Others)  
 #:Product Generation: (empty, 0~9)  
 &:Product line: (empty, P:Plus))

Brand : INNODISK  
 Applicant : INNODISK CORPORATION  
 Address : 3F-7., No. 237, Sec. 1, Datong Rd., Xizhi Dist., New Taipei City 221, Taiwan

We, International Standards Laboratory Corp., hereby certify that:

The sample ISL received which bearing the trade name and model specified above has shown to comply with the applicable technical standards as indicated in the measurement report and was tested in accordance with the measurement procedures specified. (refer to Test Report if any modifications were made for compliance). And Our laboratories is the accredited laboratories and are approved according to ISO/IEC 17025.



Standards:

FCC CFR Title 47 Part 15 Subpart B: Section 15.107 and 15.109  
ANSI C63.4-2014  
Industry Canada Interference-Causing Equipment Standard ICES-003 Issue 6: 2016  
Class B

I attest to the accuracy of data and all measurements reported herein were performed by me or were made under my supervision and are correct to the best of my knowledge and belief. I assume full responsibility for the completeness of these measurements and vouch for the qualifications of all persons taking them.

*Bert Chen*  
Bert Chen / Director



International Standards Laboratory Corp.  
 LT LAB:  
 No. 120, Lane 180, Hsin Ho Rd., Lung-Tan Dist., Tao Yuan City 325, Taiwan  
 Tel: 886-3-407-1718; Fax: 886-3-407-1738