

SPECIFICATION





全漢企業股份有限公司
FSP TECHNOLOGY INC.

台灣 桃園市建國東路 22 號
NO.22, Jianguo E. Rd., Taoyuan City, Taiwan, R.O.C.
TEL:+886-3-375-9888 FAX:+886-3-375-6966

SPECIFICATION

FSP2000-A0AGPBI

Main Feature:
Active PFC Circuit
Full Range Input
ROHS Compliance

Jan.20.2017
REV:1.5



全漢企業股份有限公司
FSP TECHNOLOGY INC.

MODEL: FSP2000-A0AGPBI

Revision History

Rev	Description	Date	Author
1.0	Public release	2016.4.6	Jimmy
1.1	4.1.2 LOAD CAPACITY SPECIFICATIONS 增加 2000W 表格 5.0 INPUT SPECIFICATION maximum 由 265 修改為 264	2016.6.13	Jimmy
1.2	5.4. EFFICIENCY 修改負載條件	2016.6.21	Jimmy
1.3	4.1.5. Over Current Protection 改為 45A(MAX) 5.0. Input Specification 1600W 的 lin 由 18A 改為 19A	2016.6.30	Jimmy
1.4	7.1 MTBF 由軍規(MIL-HDBK-217)更改為商規(SR-332)	2016.12.14	Jimmy
1.5	1.PQD 提出重新審視章節，針對章節內容重新編排 2.新增 HI POT 內容 3.修改總瓦數為 1550W	2017.1.20	Jimmy

目錄

1. GENERAL DESCRIPTION AND SCOPE	5
2. REFERENCE DOCUMENTS.....	5
2.1 EMI REGULATORY	5
3. PHYSICAL REQUIREMENTS.....	5
3.1 MECHANICAL SPECIFICATIONS.....	5
4. OUTPUT ELECTRICAL REQUIREMENTS.....	6
4.1 OUTPUT RATING	6
4.2 LOAD CAPACITY SPECIFICATIONS.....	6
4.3 HOLD-UP TIME (Full LOAD)	7
4.4 SHORT CIRCUIT PROTECTION	7
4.5 OVER CURRENT PROTECTION	7
4.6 OVER VOLTAGE PROTECTION.....	7
4.7 POWER GOOD SIGNAL	7
4.8 PS_ON #	8
4.9 +5VSB.....	9
4.10 POWER-ON TIME.....	9
4.11 RISE TIME	10
4.12 OVER SHOOT AT TURN-ON / TURN-OFF	10
4.13 RESET AFTER SHUTDOWN.....	10
4.14 +5VSB AT AC POWER-DOWN.....	10
4.15 NO LOAD OPERATION.....	10
4.16 OUTPUT TRANSIENT LOAD RESPONSE.....	11
4.17 CAPACITIVE LOAD	11
5. INPUT ELECTRICAL REQUIREMENTS.....	12
5.1 AC INPUT.....	12
5.2 INPUT UNDER VOLTAGE.....	12
5.3 INRUSH CURRENT	12
5.4 EFFICIENCY.....	13
5.5 ENERGY STAR & ErP.....	13
6. ENVIRONMENTAL REQUIREMENTS	14
6.1 TEMPERATURE RANGE	14
6.2 HUMIDITY	14
6.3 ALTITUDE	14

6.4 MECHANICAL SHOCK.....	14
6.5 RANDOM VIBRATION	14
7. SAFTY	15
7.1 LEAKAGE CURRENT	15
7.2 HI POT	15
8. LABELLING	15
8.1 MODEL NUMBER LABEL.....	15
8.2 DC OUTPUT IDENTIFICATION.....	15
9. RELIABILITY.....	15
9.1 MTBF	15

1. GENERAL DESCRIPTION AND SCOPE

This is the specification of Model FSP2000-A0AGPBI ; AC-line powered switching power supply with active PFC (Power Factor Correction) circuit, meet EN61000-3-2 and with Full Range Input features. Designed and manufactured by FSP GROUP.

The specification below is intended to describe as detailed as possible the functions and performance of the subject power supply. Any comment or additional requirements to this specification from our customers will be highly appreciated and treated as a new target for us to approach.

2. REFERENCE DOCUMENTS

The subject power supply will meet the EMI requirements and obtain main safety approvals as following:

2.1 EMI REGULATORY

- FCC Part 15 Subpart J, Class 'B' 115 Vac operation.
- CISPR 22 Class 'B' 230 Vac operation.

3. PHYSICAL REQUIREMENTS

3.1 MECHANICAL SPECIFICATIONS

The mechanical drawing of the subject power supply, which indicate the form factor, location of the mounting holes, location, the length of the connectors, and other physical specifications of the subject power supply. Please refer to the attachment drawing.

4. OUTPUT ELECTRICAL REQUIREMENTS

The subject power supply will meet all electrical specifications below, over the full operation temperature range and dynamic load regulation.

4.1 OUTPUT RATING

Output	Nominal	Regulation	Ripple/Noise	Min	Max	peak
1	+3.3V	±5%	50mV	0A	25 A	
2	+5V	±5%	50mV	0.1A	25 A	
3	+12V1	±5%	120mV	0.1A	30 A	
4	+12V2	±5%	120mV	0.1A	30 A	
5	+12V3	±5%	120mV	0.1A	30 A	
6	+12V4	±5%	120mV	0.1A	30 A	
7	+12V5	±5%	120mV	0.1A	30 A	
8	+12V6	±5%	120mV	0.1A	30 A	
9	-12V	±10%	120mV	0.0 A	0.5 A	
10	+5VSB	±5%	50mV	0 A	4A	

1. Maximum continuous total DC output power should not exceed **1550W** at 90-264Vac.
2. Maximum continuous total DC output power should not exceed 2000W at 180-264Vac.
3. Maximum continuous combined load on +3.3VDC and +5VDC outputs shall not exceed 150W.
4. Ripple and noise measurements shall be made under all specified load conditions through a single pole low pass filter with 20MHz cutoff frequency. Outputs shall be bypassed at the connector with a 0.1uF ceramic disk capacitor and a 10uF tantalum capacitor to simulate system loading.

4.2 LOAD CAPACITY SPECIFICATIONS

The cross regulation defined as follows, the voltage regulation limits DC include DC Output ripple & noise.

● 1550W

Item	Load Cond	+3.3V	+5V	+12V1	+12V2	+12V3	+12V4	+12V5	+12V6	+5Vsb	-12V
1	Min Load	0A	0.1A	0.1A	0.1A	0.1A	0.1A	0.1A	0.1A	0A	0A
2	+5Vsb Load	0A	0.1A	0.1A	0.1A	0.1A	0.1A	0.1A	0.1A	4A	0A
3	Full load1	25A	13.5A	19.4A	19.4A	19.4A	19.4A	19.4A	19.4A	2A	0.5A
4	Full load2	0A	25A	19.4A	19.4A	19.4A	19.4A	19.4A	19.4A	0A	0.5A
5	Full load3	0A	0.1A	21.5A	21.5A	21.5A	21.5A	21.5A	21.5A	0A	0A
6	Unbalance	25A	0.1A	0.1A	0.1A	0.1A	0.1A	0.1A	0.1A	0A	0A
7	Unbalance	0A	25A	0.1A	0.1A	0.1A	0.1A	0.1A	0.1A	0A	0A

● 2000W

Item	Load Cond	+3.3V	+5V	+12V1	+12V2	+12V3	+12V4	+12V5	+12V6	+5Vsb	-12V
1	Min Load	0A	0.1A	0.1A	0.1A	0.1A	0.1A	0.1A	0.1A	0A	0A
2	+5Vsb Load	0A	0.1A	0.1A	0.1A	0.1A	0.1A	0.1A	0.1A	4A	0A
3	Full load1	25A	13.5A	25.5A	25.5A	25.5A	25.5A	25.5A	25.5A	2A	0.5A
4	Full load2	0A	25A	26A	26A	26A	26A	26A	26A	0A	0A
5	Full load3	0A	0.1A	27.7A	27.7A	27.7A	27.7A	27.7A	27.7	0A	0A
6	Unbalance	25A	0.1A	0.1A	0.1A	0.1A	0.1A	0.1A	0.1A	0A	0A
7	Unbalance	0A	25A	0.1A	0.1A	0.1A	0.1A	0.1A	0.1A	0A	0A

4.3 HOLD-UP TIME (Full LOAD)

115V / 60Hz : 17 mSec. Minimum.

230V / 50Hz : 17 mSec. Minimum.

4.4 SHORT CIRCUIT PROTECTION

Output short circuit is defined to be a short circuit load of less than 0.1 ohm. In the event of an output short circuit condition on 3.3V , 5V , 12V output, the power supply will shutdown and latch off without damage to the power supply. The power supply shall return to normal operation after the short circuit has been removed and the power switch has been turned off for no more than 2 seconds.

Short the 5Vsb , the power supply will shutdown and auto restart without damage to the power supply

4.5 OVER CURRENT PROTECTION

Output	OCP point
3.3V	32A-38A
5V	32A-38A
12V ₁ ~ 12V ₆	45A(MAX)

4.6 OVER VOLTAGE PROTECTION

Output	OVP Limit (V)
5V	5.75~ 7.00 (latch)
12V ₁ ~12V ₆	13.50 ~ 15.50 (latch)
3.3V	3.76 ~ 4.8 (latch)

4.7 POWER GOOD SIGNAL

PWR_OK is a “power good” signal. It should be asserted high by the power supply to indicate that the +12 VDC, +5VDC, and +3.3VDC outputs are above the under-voltage thresholds listed and that sufficient mains energy is stored by the converter to guarantee continuous power operation. Conversely, PWR_OK should be deasserted to a low state when any of the +12 VDC, +5 VDC, or +3.3 VDC output voltages falls below its under-voltage threshold, or when mains power has been removed for a time sufficiently long such that power supply operation cannot be guaranteed beyond the power down warning time. The electrical and timing characteristics of the PWR_OK signal are given in table.

Signal Type	+5 V TTL compatible
Logic level low	< 0.4 V while sinking 4 mA
Logic level high	Between 2.4 V and 5 V output while sourcing 200 μ A
High-state output impedance	2 k Ω from output to common
PWR_OK delay	100 ms < T_3 < 500 ms
PWR_OK rise-time	$T_4 \leq 10$ ms
AC loss to PWR_OK hold-up time	$T_5 \geq 17$ ms
Power-down warning	$T_6 \geq 1$ ms

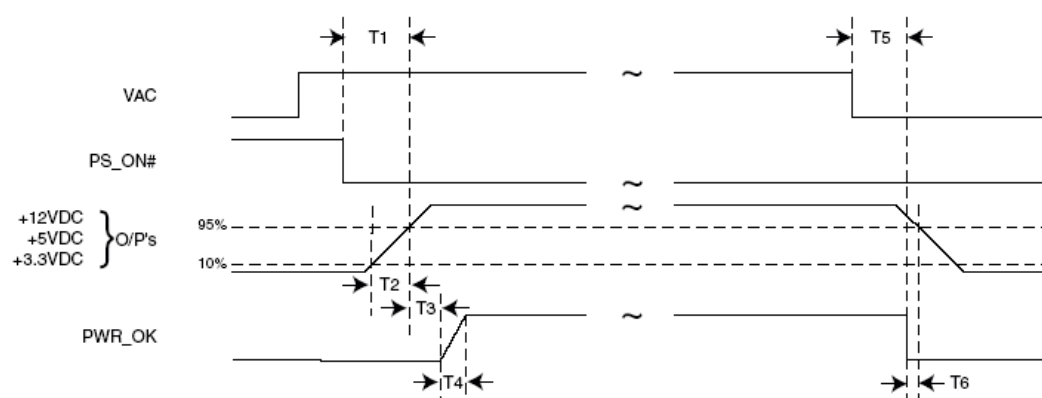

4.8 PS_ON

PS_ON# is an active-low, TTL-compatible signal that allows a motherboard to remotely control the power supply in conjunction with features such as soft on/off, Wake on LAN*, or wake-on-modem. When PS_ON# is pulled to TTL low, the power supply should turn on the four main DC output rails: +12 VDC, +5 VDC, +3.3 VDC, and -12 VDC. When PS_ON# is pulled to TTL high or open-circuited, the DC output rails should not deliver current and should be held at zero potential with respect to ground. PS_ON# has no effect on the +5 VSB output, which is always enabled whenever the AC power is present. Below table lists PS_ON# signal characteristics.

The power supply shall provide an internal pull-up to TTL high. The power supply shall also provide de-bounce circuitry on PS_ON# to prevent it from oscillating on/off at startup when activated by a mechanical switch. The DC output enable circuitry must be SELV-compliant.

The power supply shall not latch into a shutdown state when PS_ON# is driven active by pulses between 10 ms to 100 ms during the decay of the power rails.

PS_ON# Signal Characteristics

Parameter	Minimum	Maximum
V _{IL}	0	0.8 V
I _{IL} (V _{IN} = 0.4 V)	-	-1.6 mA ¹
V _{IH} (I _{IN} = - 200 uA)	2.0 V	-
V _{IH} open circuit	-	5.25 V

NOTES:

1. Negative current indicates that the current is flowing from the power supply to the motherboard.

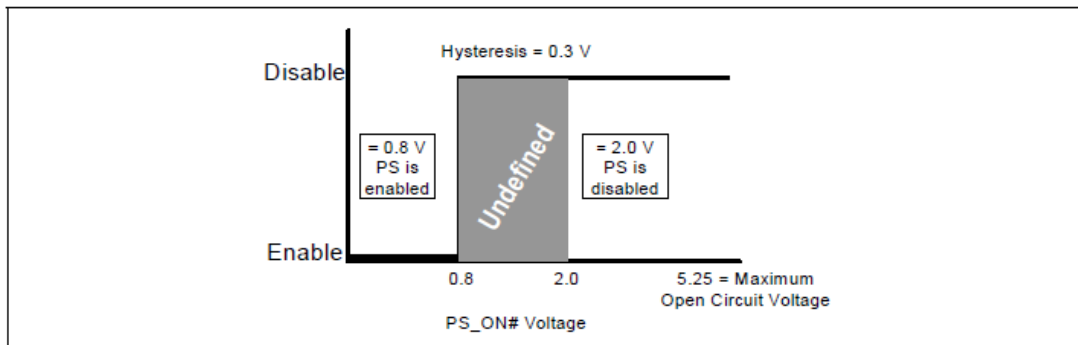
PS_ON# Signal Characteristics**4.9 +5V_{SB}**

+5 V_{sb} is a standby supply output that is active whenever the AC power is present. This output provides a power source for circuits that must remain operational when the five main DC output rails are in a disabled state. Example uses include soft power control, Wake on LAN, wake-on-modem, intrusion detection, or suspend state activities.

The power supply must be able to provide the required power during a “wake up” event. If an external USB device generates the event, there may be peak currents as high as 4.0A., lasting no more than 500 ms.

Over current protection is required on the +5 V_{sb} output regardless of the output current rating. This ensures the power supply will not be damaged if external circuits draw more current than the supply can provide.

4.10 POWER-ON TIME

The power-on time is defined as the time from when PS_ON# is pulled low to when the +12 VDC, +5 VDC, and +3.3 VDC outputs are within the regulation ranges specified in Section 4.1.7. The power-on time shall be less than 500 ms (T₁ < 500 ms). +5V_{SB} shall have a power-on time of two seconds maximum after application of valid AC voltages.4

4.11 RISE TIME

The output voltages shall rise from $\leq 10\%$ of nominal to within the regulation ranges specified in Section 4.1.7. within 0.1 ms to 20 ms ($0.1 \text{ ms} \leq T_2 \leq 20 \text{ ms}$).

There must be a smooth and continuous ramp of each DC output voltage from 10% to 90% of its final set—point within the regulation band, while loaded as specified in the Section 4.1.7. The smooth turn-on requires that, during the 10% to 90% portion of the rise time, the slope of the turn-on waveform must be positive and have a value of between 0 V/ms and $[V_{\text{out, nominal}} / 0.1]$ V/ms. Also, for any 5 ms segment of the 10% to 90% risetime waveform, a straight line drawn between the end points of the waveform segment must have a slope $\geq [V_{\text{out, nominal}} / 20]$ V/ms.

4.12 OVER SHOOT AT TURN-ON / TURN-OFF

The output voltage overshoot upon the application or removal of the input voltage, or the assertion/deassertion of PS_ON#, under the conditions specified in Section 4.1.1. shall be less than 10% above the nominal voltage. No voltage of opposite polarity shall be present on any output during turn-on or turn-off.

4.13 RESET AFTER SHUTDOWN

If the power supply latches into a shutdown status because of a fault condition on its outputs, the power supply shall return to normal operation only after the fault has been removed and the PS_ON# (or AC input) has been cycled OFF/ON with a minimum OFF time of 1 second.

4.14 +5V_{SB} AT AC POWER-DOWN

After AC power is removed, the +5V_{SB} standby voltage output should remain at its steady state value for the minimum hold-up time specified in Section 4.1.7. until the output begins to decrease in voltage. The decrease shall be monotonic in nature, dropping to 0.0 V. There shall be no other perturbations of this voltage at or following removal of AC power.

4.15 NO LOAD OPERATION

No damage or hazardous condition should occur with all the DC output connectors disconnected from the load. The power supply may latch into the shut down state.

4.16 OUTPUT TRANSIENT LOAD RESPONSE

The table summarizes the expected output transient step sizes for each output.
The transient load slew rate is = 1.0 A/us.

Output	Max. Step size (% of rate output amps)	Max. Step Size (amps)
+ 12V ₁ ~ +12V ₆	60%	
+ 5V	50%	
+ 3.3V	50%	
- 12V		0.1 A
+ 5V _{sb}		0.5 A

Output voltage should remain the regulation limits of DC voltage regulation(+5% of outputs), and the power supply should be stable when subjected to load transients. from any steady states load, including any or all of the following conditions.

4.17 CAPACITIVE LOAD

The power supply should be able to power up and operate normally with the following capacitances simultaneously present on the DC outputs. This capacitive loading should be used to check stability and should not be included for noise testing.

Output Voltage	+3.3V	+5V	+12V ₁ ~ +12V ₆	- 12V	+ 5V _{SB}
Capacitive Load	10000μF	10000μF	10000μF	350μF	10000μF

5. INPUT ELECTRICAL REQUIREMENTS

5.1 AC INPUT

Table 1 lists AC input voltage and frequency requirements for continuous operation. The power supply shall be capable of supplying full-rated output power from voltage ranges rated 100 to 240 VAC RMS nominal. The power supply shall automatically recover from AC power loss. The power supply must be able to start up under peak loading at 90 VAC.

Table 1: AC Input Requirements

● 1550W

Parameter	Minimum	Nominal	Maximum	Unit
V _{in}	90	100~240	264	Vrms
V _{in} Frequency	47	50 or 60	63	Hz
I _{in}	19A @ 100V _{AC}			Arms

● 2000W

Parameter	Minimum	Nominal	Maximum	Unit
V _{in}	180	200~240	264	Vrms
V _{in} Frequency	47	50 or 60	63	Hz
I _{in}	12A @ 200V _{AC}			Arms

5.2 INPUT UNDER VOLTAGE

The power supply shall contain protection circuitry such that the application of an input voltage below the minimum specified in this table shall not cause damage to the power supply unit nor cause failure of the input fuse.

5.3 INRUSH CURRENT

(Cold start – 25 deg. C)

115V	50A
230V	100A

5.4 EFFICIENCY

1550W

	Full load (100%)	Typical load (50%)	Light load (20%)
115VAC	89%	92%	90%
230VAC	91%	94%	90%

(loading shown in Amps)

Loading	+12V1	+12V2	+12V3	+12V4	+12V5	+12V6	+5V	+3.3V	-12V	+5Vsb
Full (100%)	19.43	19.43	19.43	19.43	19.43	19.43	16.19	16.19	0.32	2.59
Typical (50%)	9.71	9.71	9.71	9.71	9.71	9.71	8.09	8.09	0.16	1.30
Light (20%)	3.89	3.89	3.89	3.89	3.89	3.89	3.24	3.24	0.06	0.52

2000W

	Full load (100%)	Typical load (50%)	Light load (20%)
230VAC	91%	94%	90%

(loading shown in Amps)

Loading	+12V1	+12V2	+12V3	+12V4	+12V5	+12V6	+5V	+3.3V	-12V	+5Vsb
Full (100%)	25.68	25.68	25.68	25.68	25.68	25.68	15.47	15.47	0.43	3.42
Typical (50%)	12.84	12.84	12.84	12.84	12.84	12.84	7.74	7.74	0.21	1.71
Light (20%)	5.14	5.14	5.14	5.14	5.14	5.14	3.09	3.09	0.09	0.68

5.5 ENERGY STAR & ErP

The PSU shall meet ENERGY STAR 5.0 and ErP requirements, and other low Power system demands, It is recommended that the +5 VSB standby supply efficiency should be as high as possible. Standby efficiency is measured with the main outputs off (PS_ON# high state). Standby efficiency should be as shown in Table below.

Load	Efficient
45mA	≥50%
100 mA	≥55%
250 mA	≥65%
≥1A	≥75%

6. ENVIRONMENTAL REQUIREMENTS

The power supply will be compliant with each item in this specification for the following Environmental conditions.

6.1 TEMPERATURE RANGE

Operating	0 to +50 deg. C
Storage	-20 to +80 deg. C

6.2 HUMIDITY

Operating	10~90% RH, Non-condensing
Storage	95% RH, Non-condensing

6.3 ALTITUDE

Operation Altitude: 5000 meters

6.4 MECHANICAL SHOCK

The subject power supply will withstand the following imposed conditions without experiencing non-recoverable failure or deviation from specified output characteristics.

Storage 40G, 9mSec. half-sine wave pulse in both directions on three mutually perpendicular axes.

6.5 RANDOM VIBRATION

0.01g²/ Hz at 5 Hz, sloping to 0.02g²/ Hz at 20 Hz, and maintaining 0.02g²/ Hz from 20Hz to 500Hz. The area under the PSD curve is 3.13gRMS. The duration shall be 10 minutes per axis for all three axes on all samples.(non-operating)

7. SAFTY

7.1 LEAKAGE CURRENT

The leakage current from AC to safety ground will not exceed 3.5 mA-rms at 264Vac, 50 Hz.

7.2 HI POT

Specification

Primary to frame ground:shall be less than 10mA

Primary to secondary:shall be less than 10mA

Test condition

Primary to frame ground: 1800 Vac

Primary to secondary: 1800 Vac

Duration time: 60mSecond

8. LABELLING

Label marking will be permanent, legible and complied with all agency requirements.

8.1 MODEL NUMBER LABEL

Labels will be affixed to the sides of the power supply showing the following:

Manufacturer's name and logo.

- Model no., serial no., revision level, location of manufacturer.
- The total power output and the maximum load for each output.
- AC input rating.

8.2 DC OUTPUT IDENTIFICATION

Each output connector will be labeled.

9. RELIABILITY

9.1 MTBF

The power supply have a minimum predicted MTBF(SR-332) of 100,000 hours of continuous operation at 25°C,Full load, and nominal AC input voltage.