

ESM-KBLA

7th Gen Intel® Xeon™ Processors E3-15XX v6 Series Type 6
COMe Basic Module with Intel®CM238 Chipset

User's Manual

1st Ed – 05 September 2017

Copyright Notice

Copyright © 2017 ALL RIGHTS RESERVED.

Part No. E2047289200R

FCC Statement



THIS DEVICE COMPLIES WITH PART 15 FCC RULES. OPERATION IS SUBJECT TO THE FOLLOWING TWO CONDITIONS:

(1) THIS DEVICE MAY NOT CAUSE HARMFUL INTERFERENCE.

(2) THIS DEVICE MUST ACCEPT ANY INTERFERENCE RECEIVED INCLUDING INTERFERENCE THAT MAY CAUSE UNDESIRE OPERATION.

THIS EQUIPMENT HAS BEEN TESTED AND FOUND TO COMPLY WITH THE LIMITS FOR A CLASS "A" DIGITAL DEVICE, PURSUANT TO PART 15 OF THE FCC RULES.

THESE LIMITS ARE DESIGNED TO PROVIDE REASONABLE PROTECTION AGAINST HARMFUL INTERFERENCE WHEN THE EQUIPMENT IS OPERATED IN A COMMERCIAL ENVIRONMENT. THIS EQUIPMENT GENERATES, USES, AND CAN RADIATE RADIO FREQUENCY ENERGY AND, IF NOT INSTALLED AND USED IN ACCORDANCE WITH THE INSTRUCTION MANUAL, MAY CAUSE HARMFUL INTERFERENCE TO RADIO COMMUNICATIONS.

OPERATION OF THIS EQUIPMENT IN A RESIDENTIAL AREA IS LIKELY TO CAUSE HARMFUL INTERFERENCE IN WHICH CASE THE USER WILL BE REQUIRED TO CORRECT THE INTERFERENCE AT HIS OWN EXPENSE.

Notice

This guide is designed for experienced users to setup the system within the shortest time. For detailed information, please always refer to the electronic user's manual.

Copyright Notice

Copyright © 2017 ALL RIGHTS RESERVED.

No part of this document may be reproduced, copied, translated, or transmitted in any form or by any means, electronic or mechanical, for any purpose, without the prior written permission of the original manufacturer.

Trademark Acknowledgement

Brand and product names are trademarks or registered trademarks of their respective owners.

Disclaimer

We reserve the right to make changes, without notice, to any product, including circuits and/or software described or contained in this manual in order to improve design and/or performance. We assume no responsibility or liability for the use of the described product(s), conveys no license or title under any patent, copyright, or masks work rights to these products, and makes no representations or warranties that

these products are free from patent, copyright, or mask work right infringement, unless otherwise specified. Applications that are described in this manual are for illustration purposes only. We make no representation or warranty that such application will be suitable for the specified use without further testing or modification.

Life Support Policy

OUR PRODUCTS ARE NOT FOR USE AS CRITICAL COMPONENTS IN LIFE SUPPORT DEVICES OR SYSTEMS WITHOUT THE PRIOR WRITTEN APPROVAL.

As used herein:

1. Life support devices or systems are devices or systems which, (a) are intended for surgical implant into body, or (b) support or sustain life and whose failure to perform, when properly used in accordance with instructions for use provided in the labeling, can be reasonably expected to result in significant injury to the user.
2. A critical component is any component of a life support device or system whose failure to perform can be reasonably expected to cause the failure of the life support device or system, or to affect its safety or effectiveness.

A Message to the Customer

Customer Services

Each and every product is built to the most exacting specifications to ensure reliable performance in the harsh and demanding conditions typical of industrial environments. Whether your new device is destined for the laboratory or the factory floor, you can be assured that your product will provide the reliability and ease of operation.

Your satisfaction is our primary concern. Here is a guide to our customer services. To ensure you get the full benefit of our services, please follow the instructions below carefully.

Technical Support

We want you to get the maximum performance from your products. So if you run into technical difficulties, we are here to help. For the most frequently asked questions, you can easily find answers in your product documentation. These answers are normally a lot more detailed than the ones we can give over the phone. So please consult the user's manual first.

CONTENT

1. Getting Started	7
1.1 Safety Precautions	7
1.2 Packing List.....	7
1.3 Document Amendment History	8
1.4 Manual Objectives.....	9
1.5 System Specifications	10
1.6 Architecture Overview—Block Diagram	12
2. Hardware Configuration	13
2.1 Product Overview.....	14
2.2 Installation Procedure	16
2.2.1 Main Memory.....	17
2.3 Connector List.....	19
2.4 Setting Jumpers & Connectors	20
2.4.1 AT/ATX mode selector (SW1).....	20
2.4.1.1 Signal Description –AT/ATX mode selection.....	20
2.4.2 COM Express Connector 1 (CN1A)	21
2.4.2.1 Signal Description – COM Express Connector 1 (CN1A).....	25
2.4.2.1.1 Audio Signals.....	25
2.4.2.1.2 Gigabit Ethernet Signals	25
2.4.2.1.3 PCI Express Signals.....	25
2.4.2.1.4 Flat Panel LVDS Signals.....	26
2.4.2.1.5 LPC Signals.....	26
2.4.2.1.6 Miscellaneous Signals.....	26
2.4.2.1.7 GPIO Signals.....	26
2.4.2.1.8 Power Signals	27
2.4.2.1.9 Power & System Management Signals.....	27
2.4.2.1.10 SATA Signals.....	28
2.4.2.1.11 VGA Signals.....	28
2.4.2.1.12 USB Signals.....	28
2.4.2.1.13 I2C Signals.....	28
2.4.2.1.14 COM.0 Pins Signals.....	28
2.4.3 COM Express Connector 2 (CN1B)	29
2.4.3.1 Signal Description – COM Express Connector 2 (CN1B).....	33
2.4.3.1.1 USB3.0 Signals	33

2.4.3.1.2 PEG Signals	33
2.4.3.1.3 DDI Signals.....	33
3.BIOS Setup	34
3.1 Introduction	35
3.2 Starting Setup	35
3.3 Using Setup	36
3.4 Getting Help.....	37
3.5 In Case of Problems.....	37
3.6 BIOS setup.....	38
3.6.1 Main Menu.....	38
3.6.1.1 System Language.....	39
3.6.1.2 System Date	39
3.6.1.3 System Time.....	39
3.6.2 Advanced Menu	40
3.6.2.1 CPU Configuration.....	40
3.6.2.2 Power & Performance	41
3.6.2.2.1 CPU – Power Management Control	42
3.6.2.2.2 GT – Power Management Control.....	44
3.6.2.3 PCH-FW Configuration	45
3.6.2.3.1 AMT Configuration.....	46
3.6.2.3.2 Firmware Update Configuration.....	50
3.6.2.3.3 PTT Configuration.....	51
3.6.2.4 Trusted Computing	52
3.6.2.5 APCI Settings	53
3.6.2.6 NCT6106D Super IO Configuration.....	54
3.6.2.6.1 Serial Port 1 Configuration	55
3.6.2.6.2 Serial Port 2 Configuration	55
3.6.2.6.3 Parallel Port Configuration.....	56
3.6.2.7 NCT6106D HW Monitor.....	57
3.6.2.8 IT8528SEC Super IO Configuration	57
3.6.2.8.1 SER0_TX/SER0_RX (JCN3) Configuration	58
3.6.2.8.2 SER1_TX/SER1_RX (JCN3) Configuration	58
3.6.2.9 H/W Monitor.....	59
3.6.2.9.1 Smart Fan Mode Configuration	60
3.6.2.10 S5 RTC Wake Settings.....	61
3.6.2.11 Serial Port Console Redirection	63
3.6.2.11.1 Smart Fan Mode Configuration	63
3.6.2.11.2 Console Redirection Settings	65
3.6.2.11.3 Console Redirection Settings	66
3.6.2.12 Intel TXT Configuration.....	66

ESM-KBLA User's Manual

3.6.2.13	Network Stack Configuration	67
3.6.2.14	CSM Configuration	68
3.6.2.15	NVMe Configuration	70
3.6.2.16	USB Configuration	70
3.6.3	Chipset.....	72
3.6.3.1	System Agent (SA) Configuration.....	72
3.6.3.1.1	Graphics Configuration	73
3.6.3.1.2	PEG Port Configuration	76
3.6.3.2	PCH-IO Configuration.....	82
3.6.3.2.1	PCI Express Configuration	83
3.6.3.2.2	SATA And RST Configuration	88
3.6.3.2.3	USB Configuration	89
3.6.3.2.4	HD Audio Configuration	90
3.6.4	Security.....	91
3.6.4.1	Secure Boot.....	92
3.6.4.1.1	Key Management.....	93
3.6.5	Boot	93
3.6.6	Save and exit.....	94
3.6.6.1	Save Changes and Reset.....	94
3.6.6.2	Discard Changes and Reset.....	94
3.6.6.3	Restore Defaults	95
3.6.6.4	Launch EFI Shell from filesystem device	95
4.	Drivers Installation.....	96
4.1	Install Chipset Driver	97
4.2	Install Display Driver	98
4.3	Install LAN Driver (For Intel I219LM).....	99
4.4	Install ME Driver	101
4.5	Install Serial IO Driver.....	102
5.	Mechanical Drawing	103

1. Getting Started

1.1 Safety Precautions

Warning!



Always completely disconnect the power cord from your chassis whenever you work with the hardware. Do not make connections while the power is on. Sensitive electronic components can be damaged by sudden power surges. Only experienced electronics personnel should open the PC chassis.

Caution!



Always ground yourself to remove any static charge before touching the CPU card. Modern electronic devices are very sensitive to static electric charges. As a safety precaution, use a grounding wrist strap at all times. Place all electronic components in a static-dissipative surface or static-shielded bag when they are not in the chassis.

1.2 Packing List

Before you begin installing your single board, please make sure that the following materials have been shipped:

- 1 x ESM-KBLA COMe Module
- 1 x Driver/Utility DVD-ROM
- 5 x Screws
- 1 x Desiccant



If any of the above items is damaged or missing, contact your retailer.

1.3 Document Amendment History

Revision	Date	By	Comment
1 st	September 2017		Initial Release

1.4 Manual Objectives

We have tried to include as much information as possible but we have not duplicated information that is provided in the standard IBM Technical References, unless it proved to be necessary to aid in the understanding of this board.

We strongly recommend that you study this manual carefully before attempting to set up ESM-KBLA series or change the standard configurations. Whilst all the necessary information is available in this manual we would recommend that unless you are confident, you contact your supplier for guidance.

Please be aware that it is possible to create configurations within the NVRAM that make booting impossible. If this should happen, clear the NVRAM settings, (see the description of the Jumper Settings for details).

If you have any suggestions or find any errors regarding this manual and want to inform us of these, please contact our Customer Service department with the relevant details.

1.5 System Specifications

System																												
CPU	IOTG 7th Generation Intel® Xeon® Processor E3-1505M v6 / E3-1505L v6																											
BIOS	AMI uEFI BIOS, 128 Mbit SPI Flash ROM iAMT (Optional)																											
System Chipset	Intel CM238																											
I/O Chip	EC (IT8528E)																											
System Memory	Two 260-pin SODIMM DDR4 2400 / 2133 SDRAM with ECC support																											
Watchdog Timer	H/W Reset, 1sec. ~ 65535sec. and 1sec./step																											
H/W Status Monitor	Monitoring System Temperature, Voltage and FAN Status with Auto Throttling Control																											
Expansion	8 x PCIe * 1																											
I/O																												
MIO	4 x SATAIII (Support RAID0, 1, 5, 10), LPC, I2C, SPI, SMBus, 2 x UART (2-wire), SDIO (optional)																											
USB	8 x USB 2.0, 4 x USB 3.0																											
GPIO	8bit GPIO																											
Display																												
Chipset	Intel® Kaby Lake Processor integrated Graphics																											
Resolution	HDMI 1.4: 4096 x 2160 @24Hz (only one display output) DP 1.2: 4096 x 2304 @60Hz (only one display output) eDP 1.4 (optional): 4096 x 2304 @60Hz (only one display output) LVDS (via eDP-to-LVDS): 1920 x 1080 @60Hz VGA (via DP-to-VGA): 1920 x 1080 @60Hz																											
Multiple Display	Active 3 Display Combinations : IBL#567387 rev 1.1 page 74 <table border="1" data-bbox="513 1563 951 2016"> <thead> <tr> <th>Display1</th> <th>Display2</th> <th>Display3</th> </tr> </thead> <tbody> <tr> <td>DP</td> <td>DP</td> <td>DP</td> </tr> <tr> <td>DP</td> <td>DP</td> <td>HDMI</td> </tr> <tr> <td>DP</td> <td>DP</td> <td>VGA*</td> </tr> <tr> <td>DP</td> <td>HDMI</td> <td>HDMI</td> </tr> <tr> <td>HDMI</td> <td>HDMI</td> <td>HDMI</td> </tr> <tr> <td>DVI</td> <td>DVI</td> <td>DVI</td> </tr> <tr> <td>HDMI</td> <td>DVI</td> <td>DVI</td> </tr> <tr> <td>DVI</td> <td>HDMI</td> <td>HDMI</td> </tr> </tbody> </table>	Display1	Display2	Display3	DP	DP	DP	DP	DP	HDMI	DP	DP	VGA*	DP	HDMI	HDMI	HDMI	HDMI	HDMI	DVI	DVI	DVI	HDMI	DVI	DVI	DVI	HDMI	HDMI
Display1	Display2	Display3																										
DP	DP	DP																										
DP	DP	HDMI																										
DP	DP	VGA*																										
DP	HDMI	HDMI																										
HDMI	HDMI	HDMI																										
DVI	DVI	DVI																										
HDMI	DVI	DVI																										
DVI	HDMI	HDMI																										

	<p>Note: *For VGA, a DP to VGA converter is required.</p> <table border="1"> <thead> <tr> <th>Display1</th> <th>Display2</th> <th>Display3</th> </tr> </thead> <tbody> <tr> <td>eDP</td> <td>DP</td> <td>DP</td> </tr> <tr> <td>eDP</td> <td>DP</td> <td>HDMI</td> </tr> <tr> <td>eDP</td> <td>HDMI</td> <td>DP</td> </tr> <tr> <td>eDP</td> <td>HDMI</td> <td>HDMI</td> </tr> <tr> <td>eDP</td> <td>HDMI</td> <td>DVI</td> </tr> <tr> <td>eDP</td> <td>DVI</td> <td>HDMI</td> </tr> <tr> <td>eDP</td> <td>DVI</td> <td>DP</td> </tr> <tr> <td>eDP</td> <td>DP</td> <td>DVI</td> </tr> </tbody> </table> <p>Note: Depends on vary carrier board.</p>	Display1	Display2	Display3	eDP	DP	DP	eDP	DP	HDMI	eDP	HDMI	DP	eDP	HDMI	HDMI	eDP	HDMI	DVI	eDP	DVI	HDMI	eDP	DVI	DP	eDP	DP	DVI
Display1	Display2	Display3																										
eDP	DP	DP																										
eDP	DP	HDMI																										
eDP	HDMI	DP																										
eDP	HDMI	HDMI																										
eDP	HDMI	DVI																										
eDP	DVI	HDMI																										
eDP	DVI	DP																										
eDP	DP	DVI																										
HDMI	HDMI 1.4																											
LCD Interface	LVDS via CH7511B VGA via RTL2168 (DP to VGA)																											
Audio																												
Audio Amp	intel HD audio I/F																											
Ethernet																												
Ethernet Interface	Intel I219LM Gigabit Ethernet PHY																											
Mechanical & Environmental																												
Power Requirement	+9 ~ +19V																											
ACPI	Single power ATX Support S0, S3, S4, S5 ACPI 5.0 Compliant																											
Power Type	AT/ATX																											
Operating Temp.	Standard: 0 to 60°C																											
Storage Temp.	-40°C to 75°C																											
Operating Humidity	0% ~ 90% relative humidity, non-condensing																											
Size (L x W)	125 mm x 95 mm																											
Weight	0.44lbs(0.2kg)																											



Note: Specifications are subject to change without notice.

1.6 Architecture Overview—Block Diagram

The following block diagram shows the architecture and main components of ESM-KBLA.

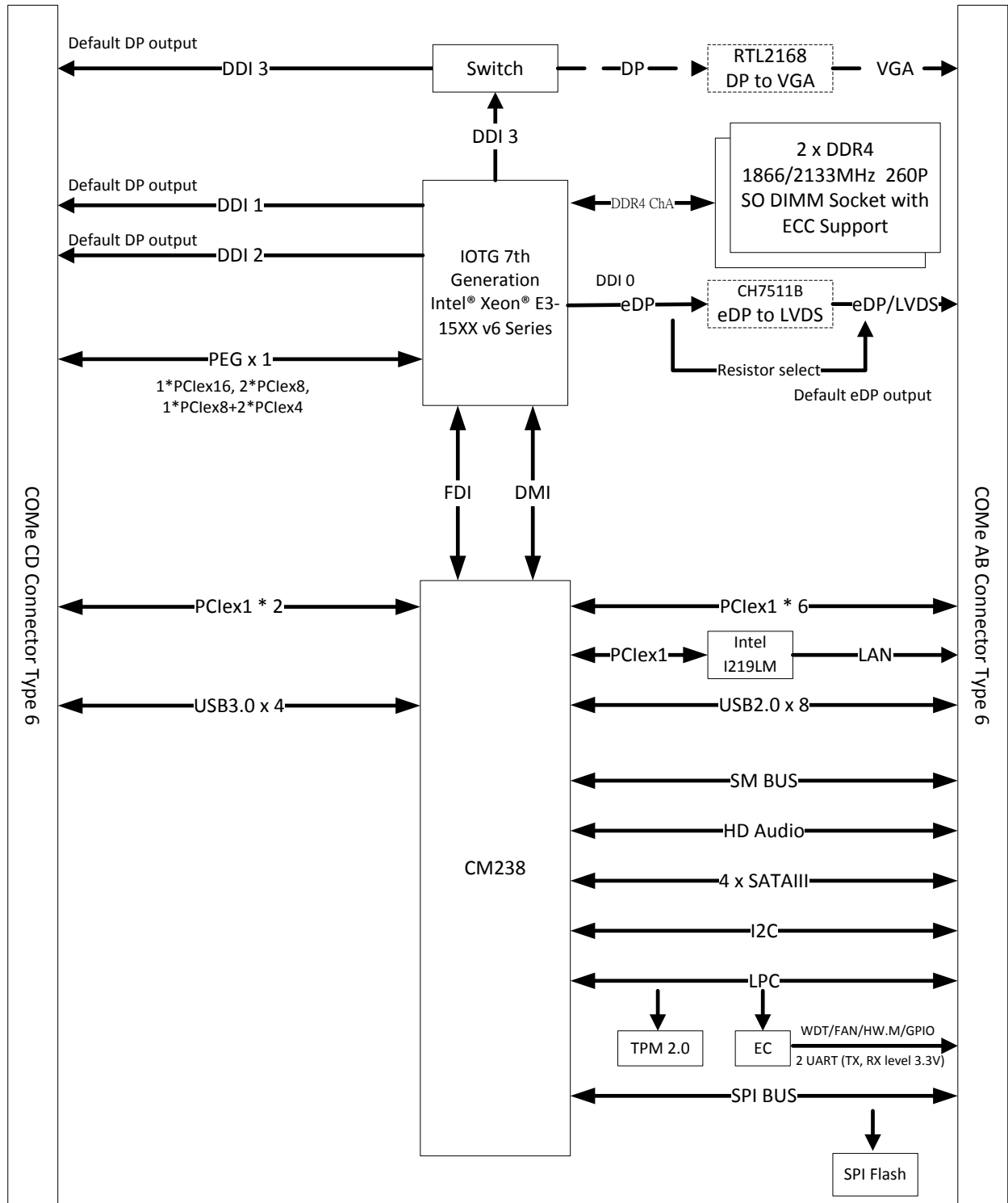

2. Hardware Configuration

2.1 Product Overview

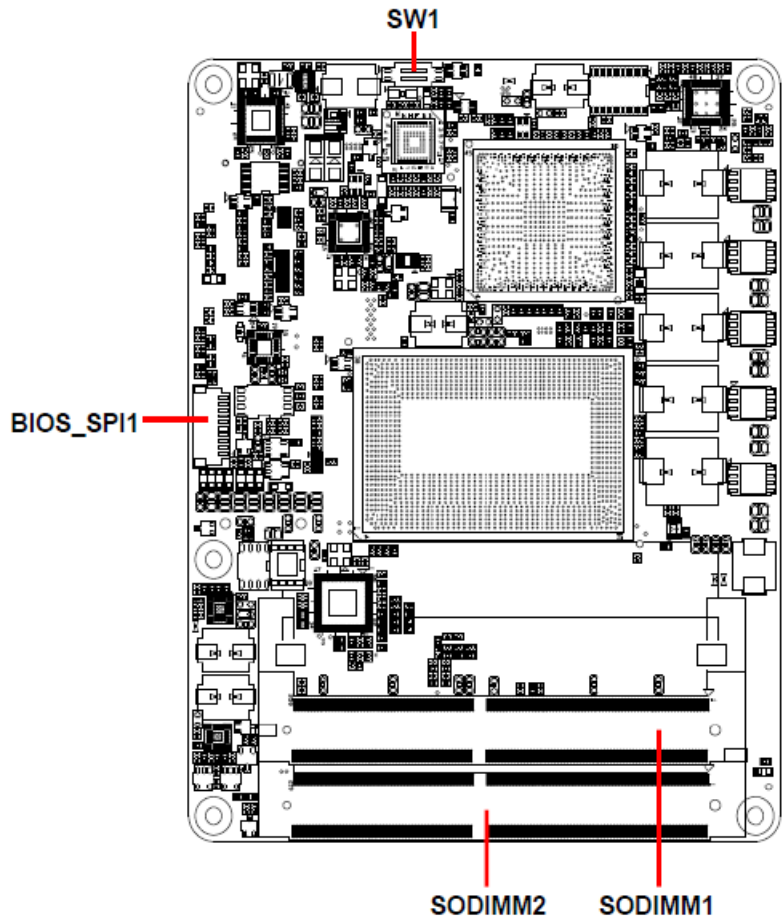

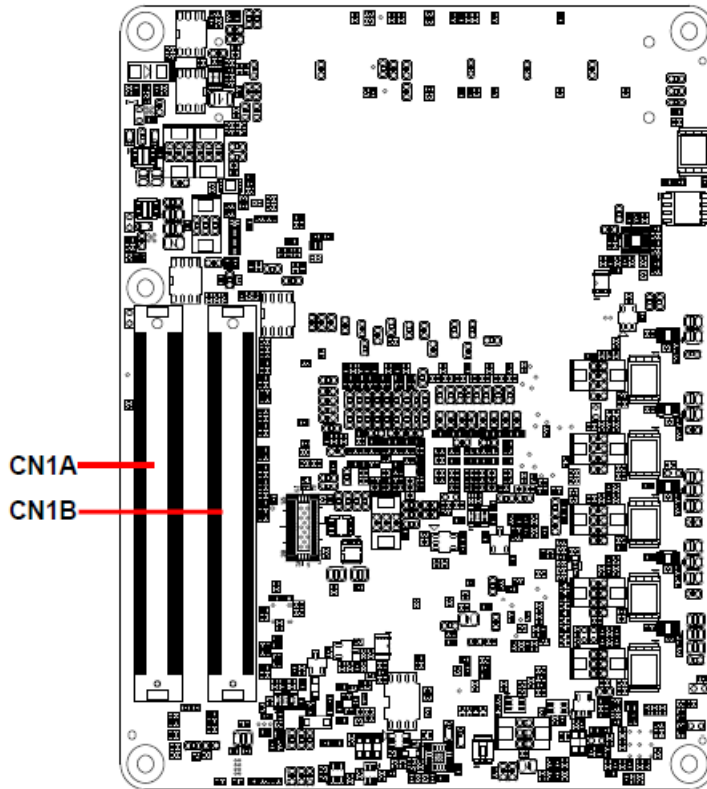

2.2 Installation Procedure

This chapter explains you the instructions of how to setup your system.

1. Turn off the power supply.
2. Insert the DIMM module (be careful with the orientation).
3. Insert all external cables for hard disk, keyboard, mouse, USB etc. except for flat panel. A CRT monitor must be connected in order to change NVRAM settings to support flat panel.
4. Connect power supply to the board via the ATXPWR.
5. Turn on the power.
6. Enter the BIOS setup by pressing the delete key during boot up. Use the "Save & Exit \ Restore Defaults" feature.
7. If TFT panel display is to be utilized, make sure the panel voltage is correctly set before connecting the display cable and turning on the power.

2.2.1 Main Memory

ESM-KBLA provides two 260-pin SODIMM socket, supports up to 32GB DDR4 2400/2133 SDRAM

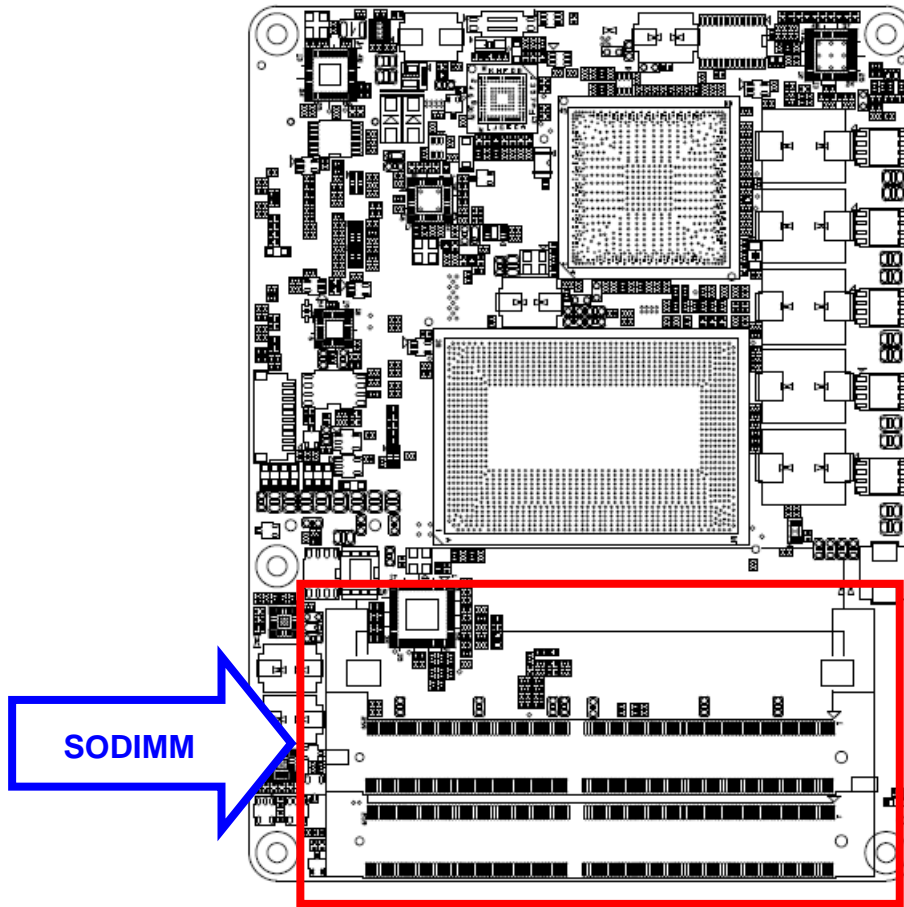

Make sure to unplug the power supply before adding or removing DIMMs or other system components. Failure to do so may cause severe damage to board and components.

ESM-KBLA User's Manual

- Locate the SODIMM socket on the board.
- Carefully hold two edges of the SODIMM module. avoid touching its connectors.
- Align the notch key on the module with the rib on the slot.
- Firmly press the modules into the socket which automatically snaps into the mounting notch. Do not force the SODIMM module in with extra force as the SODIMM module only fits in one direction.

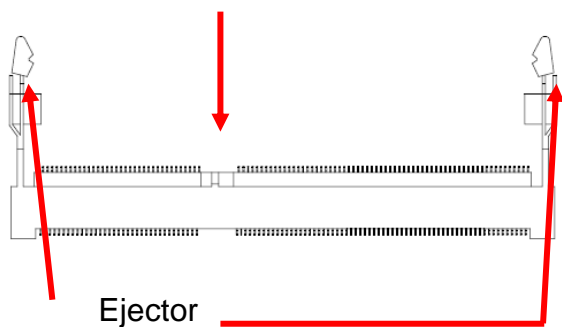
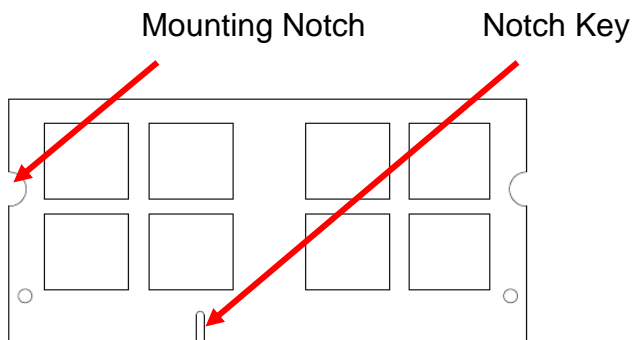

260-pin DDR4 SODIMM

- To remove SODIMM modules, simultaneously push the two ejector tabs outward, then pull out the SODIMM module.



Note:

- (1) Please do not change any DDR4 SDRAM parameter in BIOS setup to increase your system's performance without acquiring technical information in advance.
- (2) Static electricity can damage the electronic components of the computer or optional boards. Before proceeding, ensure that you are discharged of static electricity by briefly touching a grounded metal object.

2.3 Connector List

You can configure your board to match the needs of your application by setting jumpers. A jumper is the simplest kind of electric switch.

It consists of two metal pins and a small metal clip (often protected by a plastic cover) that slides over the pins to connect them. To “close” a jumper you connect the pins with the clip. To “open” a jumper you remove the clip. Sometimes a jumper will have three pins, labeled 1, 2, and 3. In this case, you would connect either two pins.

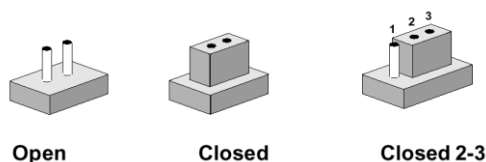

The jumper settings are schematically depicted in this manual as follows:



A pair of needle-nose pliers may be helpful when working with jumpers.

Connectors on the board are linked to external devices such as hard disk drives, a keyboard, or floppy drives. In addition, the board has a number of jumpers that allow you to configure your system to suit your application.

If you have any doubts about the best hardware configuration for your application, contact your local distributor or sales representative before you make any changes.

The following tables list the function of each of the board's jumpers and connectors.

Connectors

Label	Function	Note
BIOS_SPI1	(Reserved for BIOS programming)	5 x 2 header, pitch 2.00mm
CN1A	COM Express connector 1	
CN1B	COM Express connector 2	
SODIMM1	260-pin DDR4 SDRAM DIMM socket	
SODIMM2	260-pin DDR4 SDRAM DIMM socket	
SW1	AT/ATX mode selector	

2.4 Setting Jumpers & Connectors

2.4.1 AT/ATX mode selector (SW1)

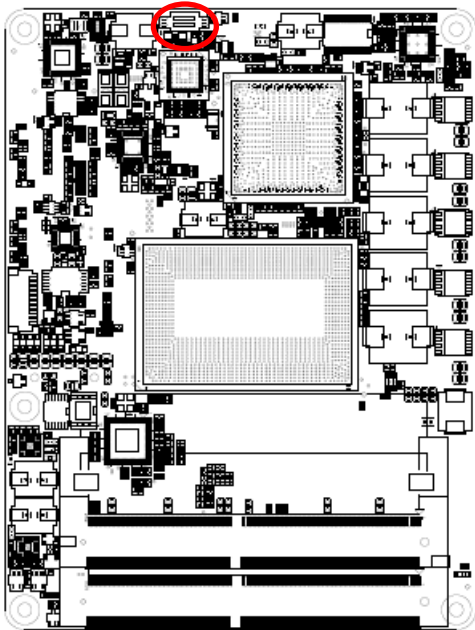

AT/ATX mode



AT mode*



ATX mode

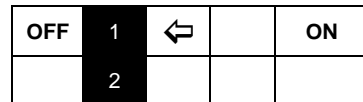

*Default

2.4.1.1 Signal Description –AT/ATX mode selection

AT/ATX mode	Description
<p>AT mode</p>	Auto-power on, no need to press Power button to enable power on/off
<p>ATX mode</p>	Press the power button to enable power on/off

2.4.2 COM Express Connector 1 (CN1A)

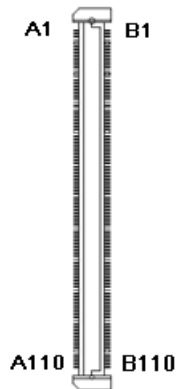
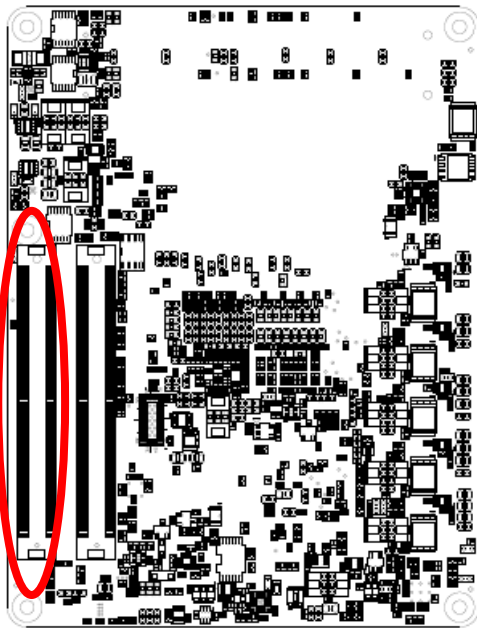

Signal	PIN	PIN	Signal
GND	A1	B1	GND
GBE0_MDI3-	A2	B2	GBE0_ACT#
GBE0_MDI3+	A3	B3	LPC_LFRAME#
GBE0_LINK100#	A4	B4	LPC_AD0
GBE0_LINK1000#	A5	B5	LPC_AD1
GBE0_MDI2-	A6	B6	LPC_AD2
GBE0_MDI2+	A7	B7	LPC_AD3
GBE0_LINK#	A8	B8	NC
GBE0_MDI1-	A9	B9	NC
GBE0_MDI1+	A10	B10	CLK_24M_CB
GND	A11	B11	GND
GBE0_MDI0-	A12	B12	PWRBTN#
GBE0_MDI0+	A13	B13	SMB_CK_A
GBE0_CTREF	A14	B14	SMB_DAT_A
SUS_S3#	A15	B15	SMB_ALERT#
SATA0_TX+	A16	B16	SATA1_TX+
SATA0_TX-	A17	B17	SATA1_TX-
SUS_S4#	A18	B18	SUS_STAT#
SATA0_RX+	A19	B19	SATA1_RX+
SATA0_RX-	A20	B20	SATA1_RX-
GND	A21	B21	GND
SATA2_TX+	A22	B22	SATA3_TX+
SATA2_TX-	A23	B23	SATA3_TX-
SUS_S5#	A24	B24	PWR_OK
SATA2_RX+	A25	B25	SATA3_RX+
SATA2_RX-	A26	B26	SATA3_RX-
BATLOW#	A27	B27	WDT
SATA_ACT#	A28	B28	NC
HDA_SYNC	A29	B29	HDA_SDI1
HDA_RST#	A30	B30	HDA_SDI0

ESM-KBLA User's Manual

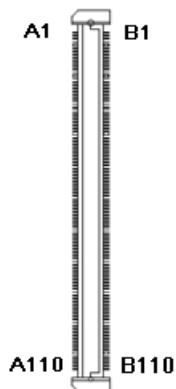
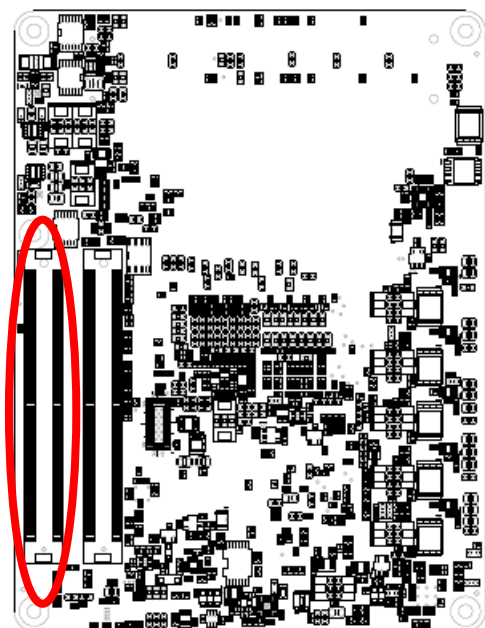

Signal	PIN	PIN	Signal
GND	A31	B31	GND
HDA_BITCLK	A32	B32	SPKR
HDA_SDOUT	A33	B33	I2C_CLK
BIOS_DIS0#	A34	B34	I2C_DATA
THRMTRIP	A35	B35	THRM#
USB6-	A36	B36	USB7-
USB6+	A37	B37	USB7+
USB_6_7_OC#	A38	B38	USB_4_5_OC#
USB4-	A39	B39	USB5-
USB4+	A40	B40	USB5+
GND	A41	B41	GND
USB2-	A42	B42	USB3-
USB2+	A43	B43	USB3+
USB_2_3_OC#	A44	B44	USB_0_1_OC#
USB0-	A45	B45	USB1-
USB0+	A46	B46	USB1+
VCC_RTC	A47	B47	EXCD1_PERST#
EXCD0_PERST#	A48	B48	EXCD1_CPPE#
EXCD0_CPPE#	A49	B49	SYS_RESET#
SERIRQ	A50	B50	CB_RESET#
GND	A51	B51	GND
PCIE_TX5+	A52	B52	PCIE_RX5+
PCIE_TX5-	A53	B53	PCIE_RX5-
GPI0	A54	B54	GPO1
PCIE_TX4+	A55	B55	PCIE_RX4+
PCIE_TX4-	A56	B56	PCIE_RX4-
GND	A57	B57	GPO2
PCIE_TX3+	A58	B58	PCIE_RX3+
PCIE_TX3-	A59	B59	PCIE_RX3-
GND	A60	B60	GND

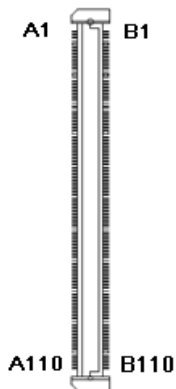
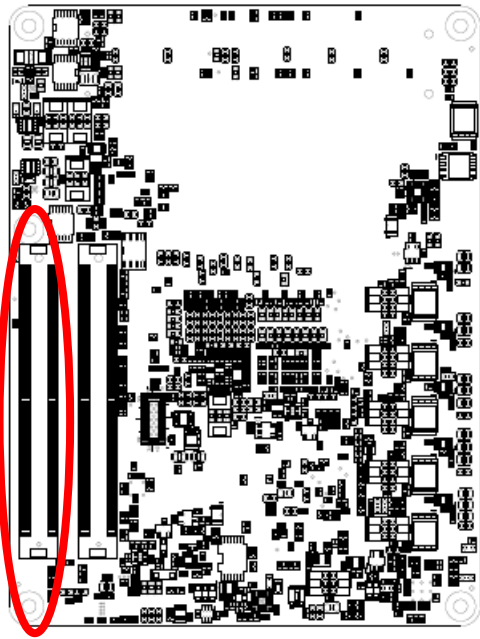

Signal	PIN	PIN	Signal
PCIE_TX2+	A61	B61	PCIE_RX2+
PCIE_TX2-	A62	B62	PCIE_RX2-
GPI1	A63	B63	GPO3
PCIE_TX1+	A64	B64	PCIE_RX1+
PCIE_TX1-	A65	B65	PCIE_RX1-
GND	A66	B66	PCIE_WAKE#
GPI2	A67	B67	WAKE1#
PCIE_TX0+	A68	B68	PCIE_RX0+
PCIE_TX0-	A69	B69	PCIE_RX0-
GND	A70	B70	GND
LVDS_A0+/EDP_TX2+	A71	B71	LVDS_B0+
LVDS_A0-/EDP_TX2-	A72	B72	LVDS_B0-
LVDS_A1+/EDP_TX1+	A73	B73	LVDS_B1+
LVDS_A1-/EDP_TX1-	A74	B74	LVDS_B1-
LVDS_A2+/EDP_TX0+	A75	B75	LVDS_B2+
LVDS_A2-/EDP_TX0-	A76	B76	LVDS_B2-
LVDS_VDD_EN/EDP_VDD_EN	A77	B77	LVDS_B3+
LVDS_A3+	A78	B78	LVDS_B3-
LVDS_A3-	A79	B79	LVDS_BKLT_EN
GND	A80	B80	GND
LVDS_A_CK+/EDP_TX3+	A81	B81	LVDS_B_CK+
LVDS_A_CK-/EDP_TX3-	A82	B82	LVDS_B_CK-
LVDS_I2C_CK/EDP_AUX+	A83	B83	LVDS_BKLT_CTRL
LVDS_I2C_DAT/EDP_AUX-	A84	B84	+ATX5VSB
GPI3	A85	B85	+ATX5VSB
KBRST#	A86	B86	+ATX5VSB
CB_EDP_HDP	A87	B87	+ATX5VSB
PCIE_CLK_REF+	A88	B88	BIOS_DIS1#
PCIE_CLK_REF-	A89	B89	VGA_RED
GND	A90	B90	GND

ESM-KBLA User's Manual

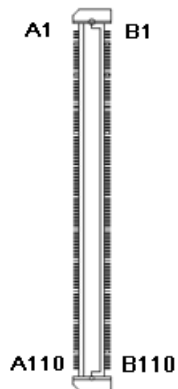
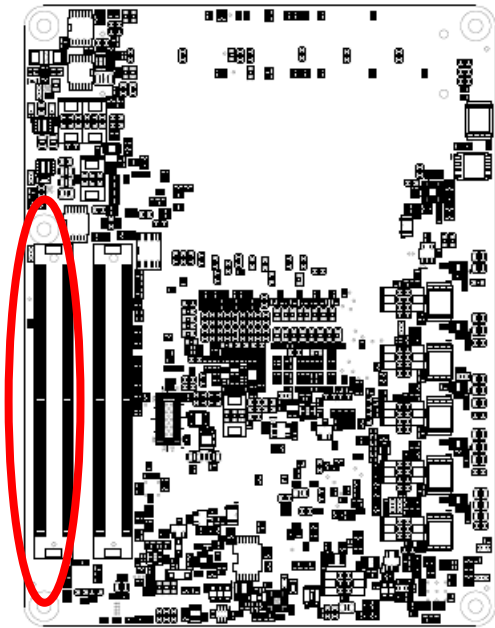

Signal	PIN	PIN	Signal
SPI_POWER	A91	B91	VGA_GRN
SPI_MISO	A92	B92	VGA_BLU
GPO0	A93	B93	VGA_HSYNC
SPI_CLK	A94	B94	VGA_VSYNC
SPI_MOSI	A95	B95	VGA_I2C_CK
PP_TPM	A96	B96	VGA_I2C_DAT
NC	A97	B97	SPI_CS#
SER0_TX	A98	B98	NC
SER0_RX	A99	B99	NC
GND	A100	B100	GND
SER1_TX	A101	B101	FAN_PWMOUT
SER1_RX	A102	B102	FAN_TACHIN
LID#	A103	B103	SLEEP#
+VIN_9V_19V	A104	B104	+VIN_9V_19V
+VIN_9V_19V	A105	B105	+VIN_9V_19V
+VIN_9V_19V	A106	B106	+VIN_9V_19V
+VIN_9V_19V	A107	B107	+VIN_9V_19V
+VIN_9V_19V	A108	B108	+VIN_9V_19V
+VIN_9V_19V	A109	B109	+VIN_9V_19V
GND	A110	B110	GND

2.4.2.1 Signal Description – COM Express Connector 1 (CN1A)

2.4.2.1.1 Audio Signals

Signal	Signal Description
HDA_SYNC	HD Audio Sync
HDA_RST#	HD Audio Reset
HDA_SDI[0:1]	Audio CODEC Serial Data
HDA_BITCLK	HD Audio Clock
HDA_SDOOUT	HD Audio Data

2.4.2.1.2 Gigabit Ethernet Signals

Signal	Signal Description																				
GBE0_MD[0:3] +/-	Gigabit Ethernet Controller 0: Media Dependent Interface Differential Pairs 0,1,2,3. The MDI can operate in 1000, 100 and 10 Mbit / sec modes. Some pairs are unused in some modes, per the following:																				
	<table border="1"> <thead> <tr> <th></th> <th>1000B-T</th> <th>100B-T</th> <th>10B-T</th> </tr> </thead> <tbody> <tr> <td>MDI[0] +/-</td> <td>B1_DA+/-</td> <td>TX+/-</td> <td>TX+/-</td> </tr> <tr> <td>MDI[1] +/-</td> <td>B1_DB+/-</td> <td>RX+/-</td> <td>RX+/-</td> </tr> <tr> <td>MDI[2] +/-</td> <td>B1_DC+/-</td> <td>X</td> <td>X</td> </tr> <tr> <td>MDI[3] +/-</td> <td>B1_DD+/-</td> <td>X</td> <td>X</td> </tr> </tbody> </table>		1000B-T	100B-T	10B-T	MDI[0] +/-	B1_DA+/-	TX+/-	TX+/-	MDI[1] +/-	B1_DB+/-	RX+/-	RX+/-	MDI[2] +/-	B1_DC+/-	X	X	MDI[3] +/-	B1_DD+/-	X	X
		1000B-T	100B-T	10B-T																	
	MDI[0] +/-	B1_DA+/-	TX+/-	TX+/-																	
	MDI[1] +/-	B1_DB+/-	RX+/-	RX+/-																	
MDI[2] +/-	B1_DC+/-	X	X																		
MDI[3] +/-	B1_DD+/-	X	X																		
GBE0_ACT#	Gigabit Ethernet Controller 0 activity indicator, active low.																				
GBE0_Link#	Gigabit Ethernet Controller 0 link indicator, active low.																				
GBE0_Link100#	Gigabit Ethernet Controller 0 100 Mbit / sec link indicator, active low.																				
GBE0_Lin1000#	Gigabit Ethernet Controller 0 1000 Mbit / sec link indicator, active low.																				

2.4.2.1.3 PCI Express Signals

Signal	Signal Description
PCIE_TX[0:6] +/-	PCI Express Differential Transmit Pair 0-6
PCIE_RX[0:6] +/-	PCI Express Differential Receive Pair 0-6
PCIE0_CK_REF +/-	Reference clock output for PCI Express lanes 0-6 and for PCI Express Graphics lanes 0-15

ESM-KBLA User's Manual

2.4.2.1.4 Flat Panel LVDS Signals

Signal	Signal Description
LVDS_BKLT_CTRL/ EDP_BKLT_CTRL	Controls panel digital power.
ENBKL#	Controls backlight power enable.
LVDS_I2C_CLK	I2C clock output for LVDS display use.
LVDS_I2C_DAT	I2C data line for LVDS display use.
LVDS_A/EDP_TX [0:3] +/-	LVDS Channel A differential pairs.
LVDS_B[0:3] +/-	LVDS Channel B differential pairs.
LVDS_VDD_EN/EDP_VDD_EN	LVDS panel power enables.
LVDS_A_CLK/EDP_TX3 +/-	LVDS Channel A differential clock.
LVDS_B_CLK +/-	LVDS Channel A differential clock.

2.4.2.1.5 LPC Signals

Signal	Signal Description
LPC_LFRAME#	LPC frame indicates the start of an LPC cycle
LPC_AD[0:3]	LPC multiplexed address, command and data bus
LPC_DRQ[0:1]#	LPC serial DMA request
LPC_CLK	LPC clock output - 33MHz nominal
SERIRQ	LPC serial interrupt

2.4.2.1.6 Miscellaneous Signals

Signal	Signal Description																																								
SPKR	Output for audio enunciator - the "speaker" in PC-AT systems																																								
BIOS_DIS0# BIOS_DIS1#	<p>Selection straps to determine the BIOS boot device</p> <table border="1"> <thead> <tr> <th>BIOS_DIS1#</th> <th>BIOS_DIS0#</th> <th>Chipset SPI CS1# Destination</th> <th>Chipset SPI CS0# Destination</th> <th>Carrier SPI_CS#</th> <th>SPI Descriptor</th> <th>Bios Entry</th> <th>Ref Line</th> </tr> </thead> <tbody> <tr> <td>1</td> <td>1</td> <td>Module</td> <td>Module</td> <td>High</td> <td>Module</td> <td>SPI0/SPI1</td> <td>0</td> </tr> <tr> <td>1</td> <td>0</td> <td>Module</td> <td>Module</td> <td>High</td> <td>Module</td> <td>Carrier FWH</td> <td>1</td> </tr> <tr> <td>0</td> <td>1</td> <td>Module</td> <td>Carrier</td> <td>SPI0</td> <td>Carrier</td> <td>SPI0/SPI1</td> <td>2</td> </tr> <tr> <td>0</td> <td>0</td> <td>Carrier</td> <td>Module</td> <td>SPI1</td> <td>Module</td> <td>SPI0/SPI1</td> <td>3</td> </tr> </tbody> </table>	BIOS_DIS1#	BIOS_DIS0#	Chipset SPI CS1# Destination	Chipset SPI CS0# Destination	Carrier SPI_CS#	SPI Descriptor	Bios Entry	Ref Line	1	1	Module	Module	High	Module	SPI0/SPI1	0	1	0	Module	Module	High	Module	Carrier FWH	1	0	1	Module	Carrier	SPI0	Carrier	SPI0/SPI1	2	0	0	Carrier	Module	SPI1	Module	SPI0/SPI1	3
BIOS_DIS1#	BIOS_DIS0#	Chipset SPI CS1# Destination	Chipset SPI CS0# Destination	Carrier SPI_CS#	SPI Descriptor	Bios Entry	Ref Line																																		
1	1	Module	Module	High	Module	SPI0/SPI1	0																																		
1	0	Module	Module	High	Module	Carrier FWH	1																																		
0	1	Module	Carrier	SPI0	Carrier	SPI0/SPI1	2																																		
0	0	Carrier	Module	SPI1	Module	SPI0/SPI1	3																																		

2.4.2.1.7 GPIO Signals

Signal	Signal Description
GPI[0:4]	General purpose input pins.
GPO[0:4]	General purpose output pins.

2.4.2.1.8 Power Signals

Signal	Signal Description
+ATX5VSB	Standby power input: +5.0V nominal. See Electrical Specifications for allowable input range. If VCC5_SBY is used, all available +ATX5VSB pins on the connector(s) must be used. Only used for standby and suspend functions. May be left unconnected if these functions are not used in the system design.
VCC_RTC	Real-time clock circuit-power input. Nominally +3.0V.

2.4.2.1.9 Power & System Management Signals

Signal	Signal Description
SUS_S3#	Indicates system is in Suspend to RAM state. Active low output.
SUS_S4#	Indicates system is in Suspend to Disk state. Active low output.
SUS_S5#	Indicates system is in Soft Off state.
BATLOW#	Indicates that external battery is low
PWRBTN#	Power button to bring system out of S5 (soft off), active on rising edge.
SMB_CK	System Management Bus bidirectional clock line.
SMB_DTA	System Management Bus bidirectional data line.
SMB_ALERT#	System Management Bus Alert - input can be used to generate an SMI# (System Management Interrupt) or to wake the system.
SUS_STAT#	Indicates imminent suspend operation.
PWR_OK	Power OK from main power supply
SYS_RESET#	Reset button input. Active low input.
WAKE0#	PCI Express wake up signal.
WAKE1#	General purpose wake up signal.

ESM-KBLA User's Manual

2.4.2.1.10 SATA Signals

Signal	Signal Description
SATA[0:3]_TX +/-	Serial ATA Channel 0-3 transmit differential pair.
SATA[0:3]_RX +/-	Serial ATA Channel 0-3 receive differential pair.
ATA_ACT#	ATA (parallel and serial) activity indicator, active low.

2.4.2.1.11 VGA Signals

Signal	Signal Description
VGA_RED	Red for monitor. Analog DAC output.
VGA_GRN	Green for monitor. Analog DAC output.
VGA_BLU	Blue for monitor. Analog DAC output.
VGA_HSYNC	Horizontal sync output to VGA monitor
VGA_VSYNC	Vertical sync output to VGA monitor
VGA_I ² C_CLK	DDC clock line (I2C port dedicated to identify VGA monitor capabilities)
VGA_I ² C_DAT	DDC data line.

2.4.2.1.12 USB Signals

Signal	Signal Description
USB[0:7] +/-	USB differential pairs, channels 0 through 7
USB_0_1_OC#	USB over-current sense, USB channels 0 and 1
USB_2_3_OC#	USB over-current sense, USB channels 2 and 3
USB_4_5_OC#	USB over-current sense, USB channels 4 and 5
USB_6_7_OC#	USB over-current sense, USB channels 6 and 7

2.4.2.1.13 I2C Signals

Signal	Signal Description
I2C_CLK	General purpose I2C port clock output.
I2C_DATA	General purpose I2C port data I/O line.

2.4.2.1.14 COM.0 Pins Signals

Signal	Signal Description
SER0/1_TX	TTL level outputs from the Module.
SER0/1_RX	TTL level inputs from the Module.

2.4.3 COM Express Connector 2 (CN1B)

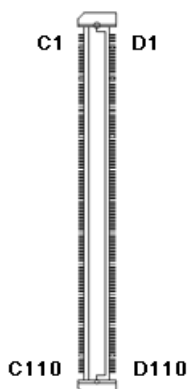
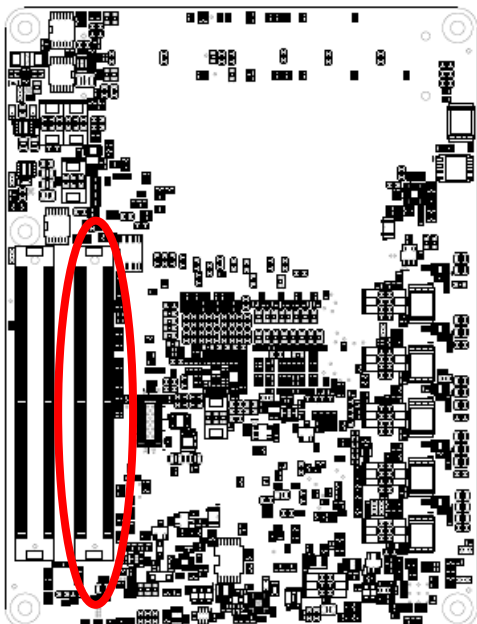

Signal	PIN	PIN	Signal
GND	C1	D1	GND
GND	C2	D2	GND
USB_SSRX0-	C3	D3	USB_SSTX0-
USB_SSRX0+	C4	D4	USB_SSTX0+
GND	C5	D5	GND
USB_SSRX1-	C6	D6	USB_SSTX1-
USB_SSRX1+	C7	D7	USB_SSTX1+
GND	C8	D8	GND
USB_SSRX2-	C9	D9	USB_SSTX2-
USB_SSRX2+	C10	D10	USB_SSTX2+
GND	C11	D11	GND
USB_SSRX3-	C12	D12	USB_SSTX3-
USB_SSRX3+	C13	D13	USB_SSTX3+
GND	C14	D14	GND
NC	C15	D15	DDI1_CTRLCLK_AUX+
NC	C16	D16	DDI1_CTRLCLK_AUX-
LVDS_BLUP	C17	D17	NC
LVDS_BLDN	C18	D18	NC
PCIE_RX6+	C19	D19	PCIE_TX6+
PCIE_RX6-	C20	D20	PCIE_TX6-
GND	C21	D21	GND
PCIE_RX7+	C22	D22	PCIE_TX7+
PCIE_RX7-	C23	D23	PCIE_TX7-
DDI1_HPD	C24	D24	NC
NC	C25	D25	NC
NC	C26	D26	DDI1_PAIR0+
PEG_GEN3_RESTE#	C27	D27	DDI1_PAIR0-
NC	C28	D28	NC
NC	C29	D29	DDI1_PAIR1+
NC	C30	D30	DDI1_PAIR1-

ESM-KBLA User's Manual

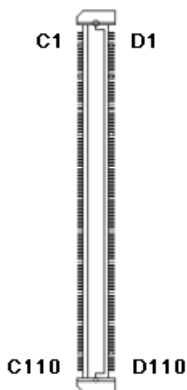
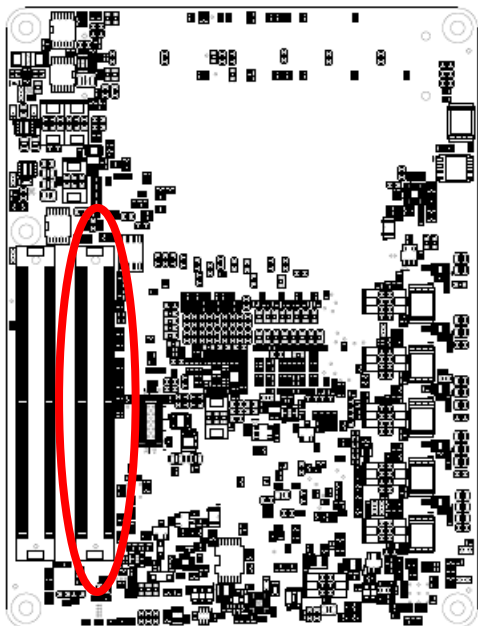

Signal	PIN	PIN	Signal
GND	C31	D31	GND
DDI2_CTRLCLK_AUX+	C32	D32	DDI1_PAIR2+
DDI2_CTRLDATA_AUX-	C33	D33	DDI1_PAIR2-
DDI2_DDC_AUX_SEL	C34	D34	DDI1_DDC_AUX_SEL
NC	C35	D35	NC
DDI3_CTRLCLK_AUX+	C36	D36	DDI1_PAIR3+
DDI3_CTRLDATA_AUX-	C37	D37	DDI1_PAIR3-
DDI3_DDC_AUX_SEL	C38	D38	NC
DDI3_PAIR0+	C39	D39	DDI2_PAIR0+
DDI3_PAIR0-	C40	D40	DDI2_PAIR0-
GND	C41	D41	GND
DDI3_PAIR1+	C42	D42	DDI2_PAIR1+
DDI3_PAIR1-	C43	D43	DDI2_PAIR1-
DDI3_HPDP	C44	D44	DDI2_HPDP
NC	C45	D45	NC
DDI3_PAIR2+	C46	D46	DDI2_PAIR2+
DDI3_PAIR2-	C47	D47	DDI2_PAIR2-
NC	C48	D48	NC
DDI3_PAIR3+	C49	D49	DDI2_PAIR3+
DDI3_PAIR3-	C50	D50	DDI2_PAIR3-
GND	C51	D51	GND
PEG_RX0+	C52	D52	PEG_TX0+
PEG_RX0-	C53	D53	PEG_TX0-
TYPE0#	C54	D54	PEG_LAN_RV#
PEG_RX1+	C55	D55	PEG_TX1+
PEG_RX1-	C56	D56	PEG_TX1-
TYPE1#	C57	D57	TYPE2#
PEG_RX2+	C58	D58	PEG_TX2+
PEG_RX2-	C59	D59	PEG_TX2-
GND	C60	D60	GND

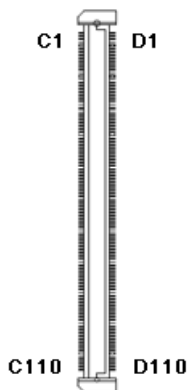
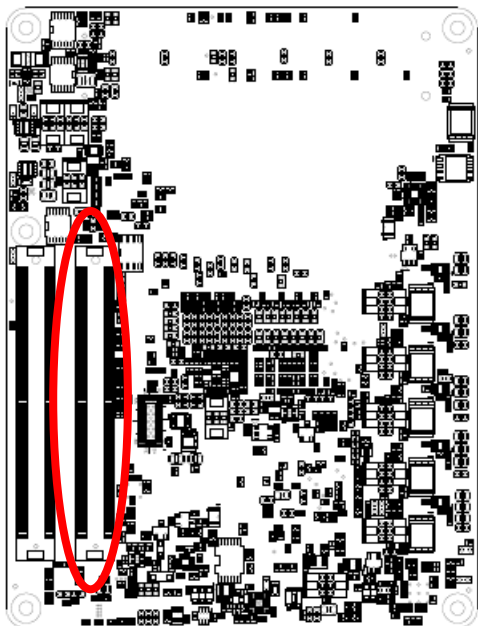

Signal	PIN	PIN	Signal
PEG_RX3+	C61	D61	PEG_TX3+
PEG_RX3-	C62	D62	PEG_TX3-
NC	C63	D63	NC
NC	C64	D64	NC-
PEG_RX4+	C65	D65	PEG_TX4+
PEG_RX4-	C66	D66	PEG_TX4-
NC	C67	D67	GND
PEG_RX5+	C68	D68	PEG_TX5+
PEG_RX5-	C69	D69	PEG_TX5-
GND	C70	D70	GND
PEG_RX6+	C71	D71	PEG_TX6+
PEG_RX6-	C72	D72	PEG_TX6-
GND	C73	D73	GND
PEG_RX7+	C74	D74	PEG_TX7+
PEG_RX7-	C75	D75	PEG_TX7-
GND	C76	D76	GND
NC	C77	D77	NC
PEG_RX8+	C78	D78	PEG_TX8+
PEG_RX8-	C79	D79	PEG_TX8-
GND	C80	D80	GND
PEG_RX9+	C81	D81	PEG_TX9+
PEG_RX9-	C82	D82	PEG_TX9-
NC	C83	D83	NC
GND	C84	D84	GND
PEG_RX10+	C85	D85	PEG_TX10+
PEG_RX10-	C86	D86	PEG_TX10-
GND	C87	D87	GND
PEG_RX11+	C88	D88	PEG_TX11+
PEG_RX11-	C89	D89	PEG_TX11-
GND	C90	D90	GND

ESM-KBLA User's Manual

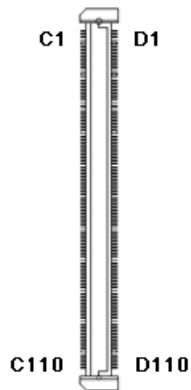
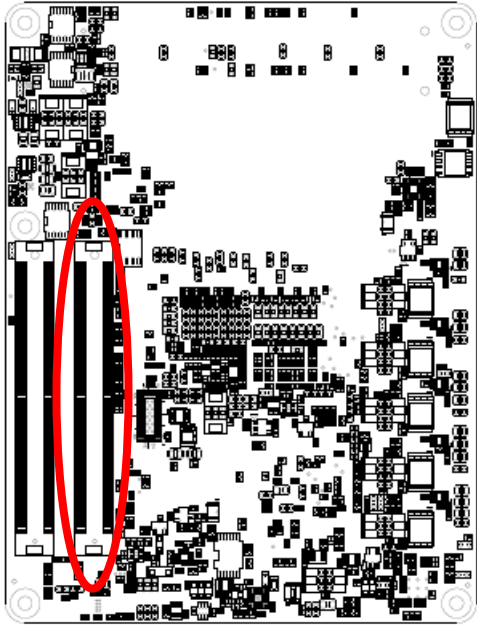

Signal	PIN	PIN	Signal
PEG_RX12+	C91	D91	PEG_TX12+
PEG_RX12-	C92	D92	PEG_TX12-
GND	C93	D93	GND
PEG_RX13+	C94	D94	PEG_TX13+
PEG_RX13-	C95	D95	PEG_TX13-
GND	C96	D96	GND
NC	C97	D97	NC
PEG_RX14+	C98	D98	PEG_TX14+
PEG_RX14-	C99	D99	PEG_TX14-
GND	C100	D100	GND
PEG_RX15+	C101	D101	PEG_TX15+
PEG_RX15-	C102	D102	PEG_TX15-
GND	C103	D103	GND
+VIN_9V_19V	C104	D104	+VIN_9V_19V
+VIN_9V_19V	C105	D105	+VIN_9V_19V
+VIN_9V_19V	C106	D106	+VIN_9V_19V
+VIN_9V_19V	C107	D107	+VIN_9V_19V
+VIN_9V_19V	C108	D108	+VIN_9V_19V
+VIN_9V_19V	C109	D109	+VIN_9V_19V
GND	C110	D110	GND

2.4.3.1 Signal Description – COM Express Connector 2 (CN1B)

2.4.3.1.1 USB3.0 Signals

Signal	Signal Description
USB_SSTX[0:3]+ USB_SSTX[0:3]-	Additional transmit signal differential pairs for the SuperSpeed USB data path.
USB_SSRX[0:3]+ USB_SSRX[0:3]-	Additional receive signal differential pairs for the SuperSpeed USB data path.

2.4.3.1.2 PEG Signals

Signal	Signal Description
PEG_TX[0:15]+ PEG_TX[0:15]-	PCI Express Graphics transmit differential paris.
PEG_RX[0:15]+ PEG_RX[0:15]-	PCI Express Graphics recevie differential paris.
PEG_LAN_RV#	PCI Express Graphics lane reversal input strap. Pull low on the Carrier board to reverse lane order.

2.4.3.1.3 DDI Signals

Signal	Signal Description
DDI[1:3]_PAIR[0:3]+ DDI[1:3]_PAIR [0:3]-	Digital Display Interface 1 to 3 Pair[0:3] differential pairs
DDI[1:3]_DDC_AUX_SEL	Selects the function of DDI[1:3]_CTRLCLK_AUX+ and DDI[1:3]_CTRLDATA_AUX-. If this input is floating the AUX pair is used for the DP AUX+/- signals. If pulled-high the AUX pair contains the CRTLCLK and CTRLDATA signals.
DDI[1:3]_CTRLCLK_AUX+	DP AUX+function if DDI[1:3]_DDC_AUX_SEL is no connect HDMI/DVI 12C CTRLCLK if DDI[1:3]_DDC_AUX_SEL is pulled high
DDI[1:3]_CTRLDATA_AUX-	DP AUX-function if DDI[1:3]_DDC_AUX_SEL is no connect HDMI/DVI 12C CTRLDATA if DDI[1:3]_DDC_AUX_SEL is pulled high
DDI[1:3]_HPD	Digital Display Interface Hot-Plug Detect

3. BIOS Setup



3.1 Introduction

The BIOS setup program allows users to modify the basic system configuration. In this following chapter will describe how to access the BIOS setup program and the configuration options that may be changed.

3.2 Starting Setup

AMI BIOS™ is immediately activated when you first power on the computer. The BIOS reads the system information contained in the NVRAM and begins the process of checking out the system and configuring it. When it finishes, the BIOS will seek an operating system on one of the disks and then launch and turn control over to the operating system.

While the BIOS is in control, the Setup program can be activated in one of two ways:

By pressing <F2> or immediately after switching the system on, or

By pressing the <F2> or key when the following message appears briefly at the left-top of the screen during the POST (Power On Self Test).

Press <F2> or to enter SETUP

If the message disappears before you respond and you still wish to enter Setup, restart the system to try again by turning it OFF then ON or pressing the "RESET" button on the system case. You may also restart by simultaneously pressing <Ctrl>, <Alt>, and <Delete> keys.

3.3 Using Setup

In general, you use the arrow keys to highlight items, press <Enter> to select, use the PageUp and PageDown keys to change entries, press <F1> for help and press <Esc> to quit. The following table provides more detail about how to navigate in the Setup program using the keyboard.

Button	Description
↑	Move to previous item
↓	Move to next item
←	Move to the item in the left hand
→	Move to the item in the right hand
Esc key	Main Menu -- Quit and not save changes into NVRAM Status Page Setup Menu and Option Page Setup Menu -- Exit current page and return to Main Menu
+ key	Increase the numeric value or make changes
- key	Decrease the numeric value or make changes
F1 key	General help, only for Status Page Setup Menu and Option Page Setup Menu
F2 key	Previous Values
F3 key	Optimized defaults
F4 key	Save & Exit Setup

- **Navigating Through The Menu Bar**

Use the left and right arrow keys to choose the menu you want to be in.



Note: Some of the navigation keys differ from one screen to another.

- **To Display a Sub Menu**

Use the arrow keys to move the cursor to the sub menu you want. Then press <Enter>. A “➤” pointer marks all sub menus.

3.4 Getting Help

Press F1 to pop up a small help window that describes the appropriate keys to use and the possible selections for the highlighted item. To exit the Help Window press <Esc> or the F1 key again.

3.5 In Case of Problems

If, after making and saving system changes with Setup, you discover that your computer no longer is able to boot, the BIOS supports an override to the NVRAM settings which resets your system to its defaults.

The best advice is to only alter settings which you thoroughly understand. To this end, we strongly recommend that you avoid making any changes to the chipset defaults. These defaults have been carefully chosen by both your systems manufacturer to provide the absolute maximum performance and reliability. Even a seemingly small change to the chipset setup has the potential for causing you to use the override.

3.6 BIOS setup

Once you enter the Aptio Setup Utility, the Main Menu will appear on the screen. The Main Menu allows you to select from several setup functions and exit choices. Use the arrow keys to select among the items and press <Enter> to accept and enter the sub-menu.

3.6.1 Main Menu

This section allows you to record some basic hardware configurations in your computer and set the system clock.

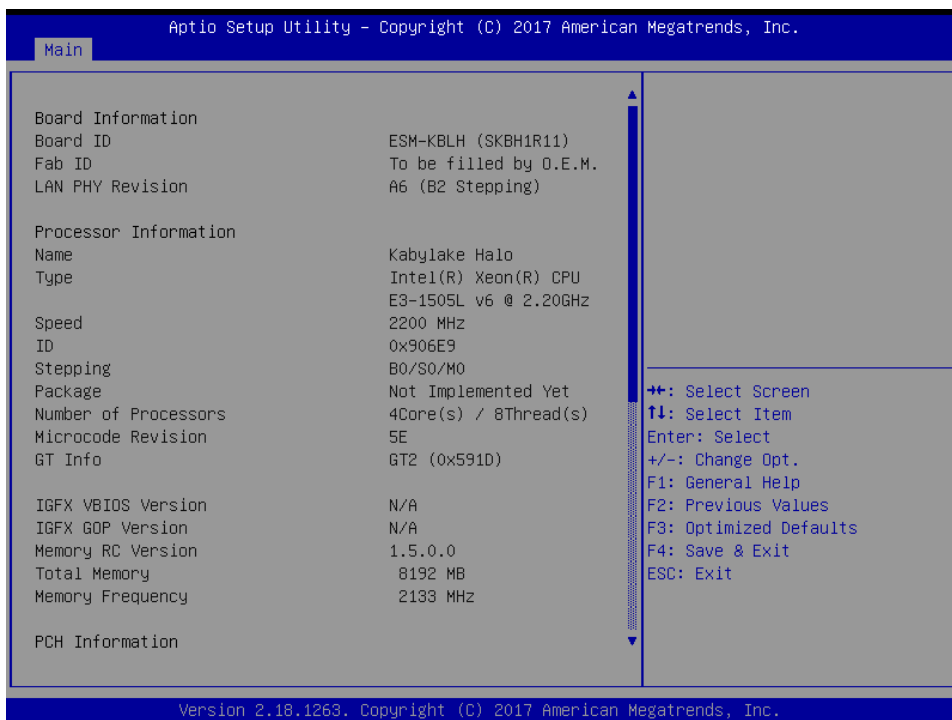

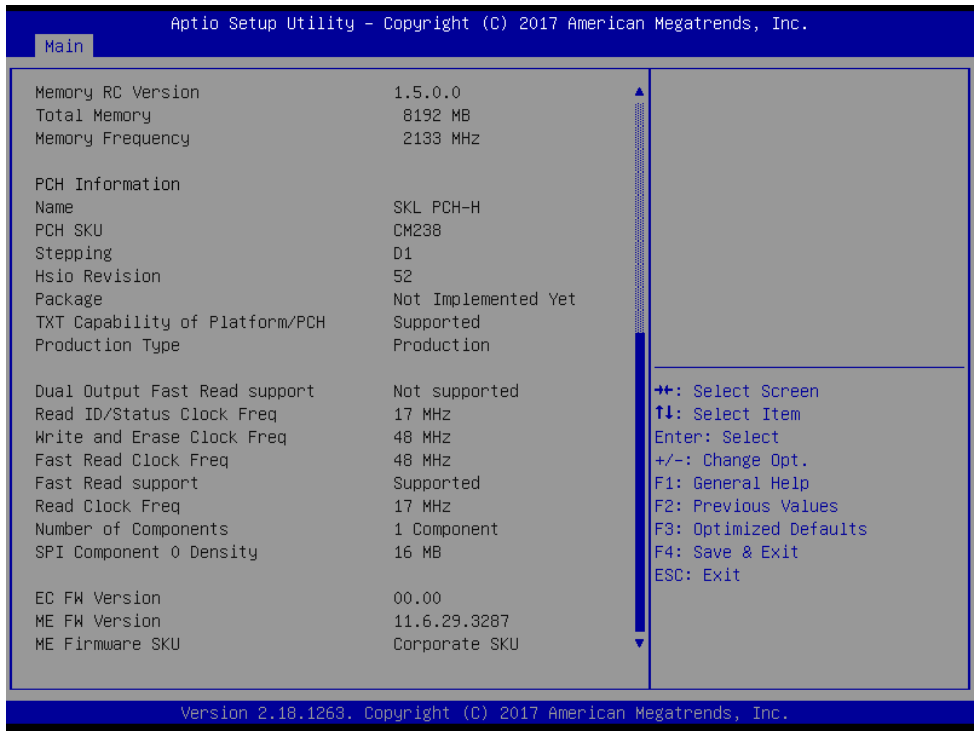

3.6.1.1 System Language

This option allows choosing the system default language.

3.6.1.2 System Date

Use the system date option to set the system date. Manually enter the day, month and year.

3.6.1.3 System Time

Use the system time option to set the system time. Manually enter the hours, minutes and seconds.



Note: The BIOS setup screens shown in this chapter are for reference purposes only, and may not exactly match what you see on your screen.

ESM-KBLA User's Manual

3.6.2 Advanced Menu

This section allows you to configure your CPU and other system devices for basic operation through the following sub-menus.

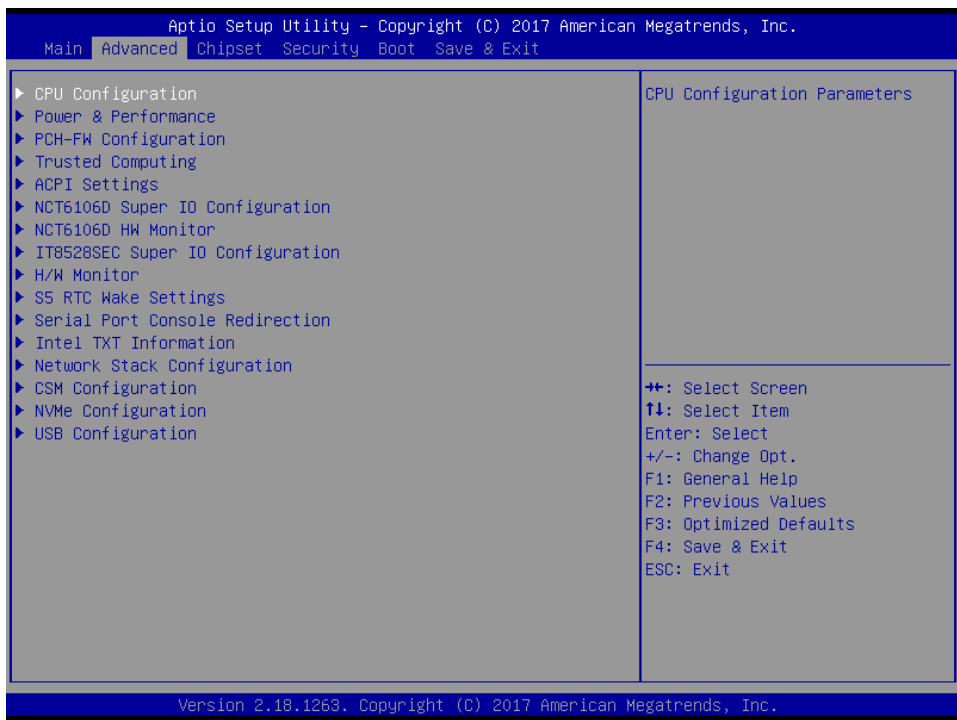

3.6.2.1 CPU Configuration

Use the CPU configuration menu to view detailed CPU specification and configure the CPU.

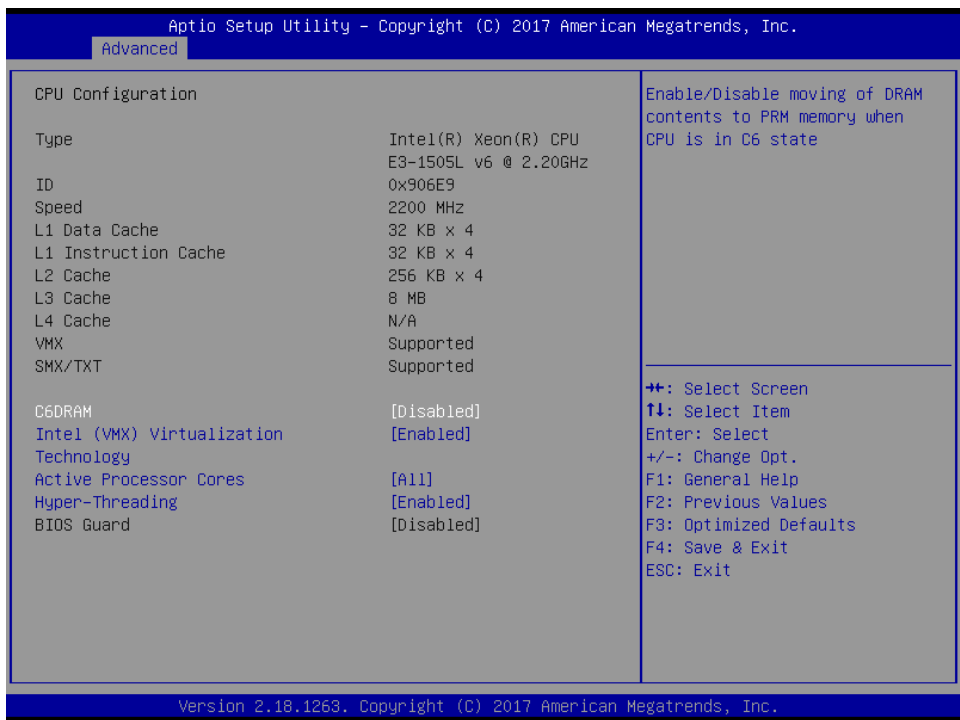

Item	Options	Description
C6DRAM	Disabled[Default] Enabled	Enable/Disable moving of DRAM contents to PRM memory when CPU is in C6 state.
Intel (VMX) Virtualization Technology	Disabled Enabled[Default]	When enabled, a VMM can utilize the additional hardware capabilities provided by Vanderpool Technology.
Active Processor Cores	All[Default] 1 2 3	Number of cores to enable in each processor package.
Hyper-Threading	Disabled, Enabled[Default]	Enabled for Windows XP and Linux (OS optimized for Hyper- Threading Technology) and Disabled for other OS (OS not optimized for Hyper- Threading Technology).

3.6.2.2 Power & Performance

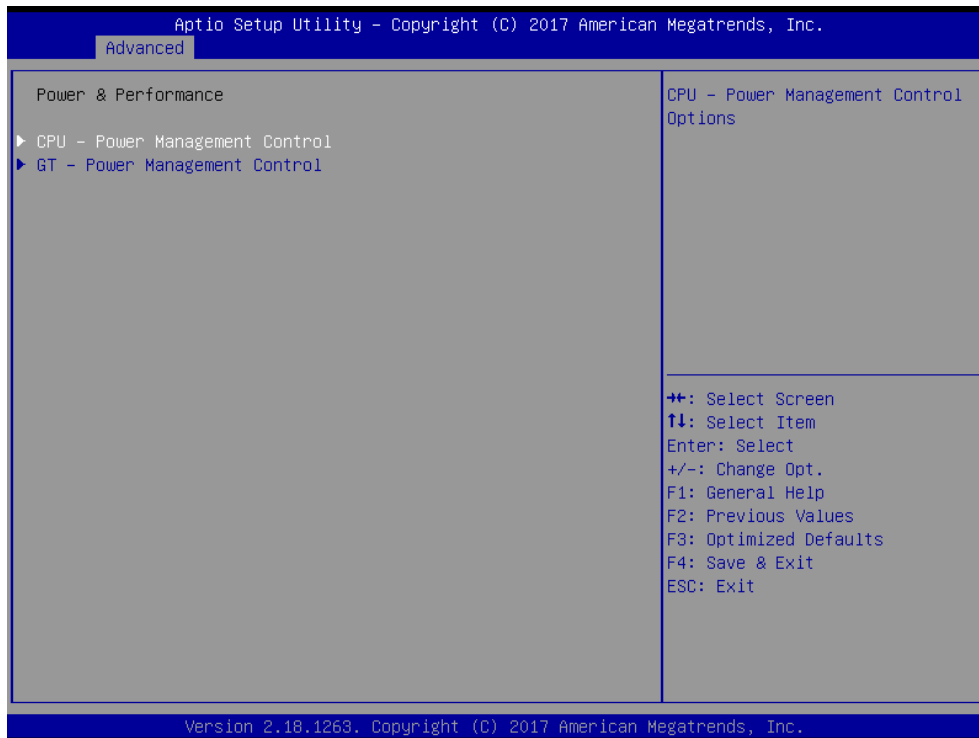

3.6.2.2.1 CPU – Power Management Control

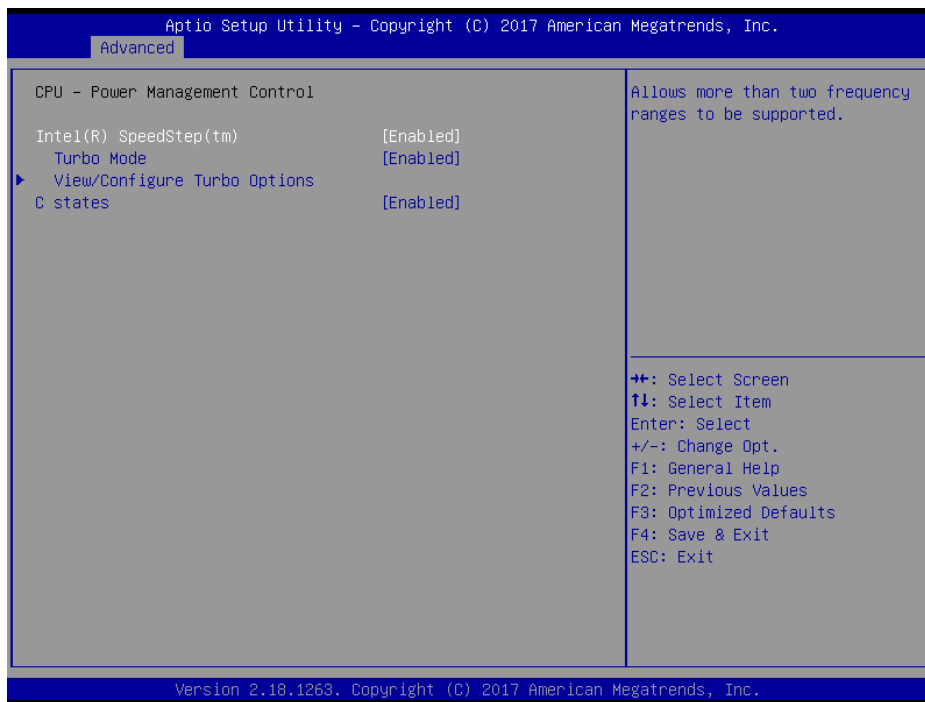

Item	Option	Description
Intel® SpeedStep™	Enabled[Default], Disabled	Allows more than two frequency ranges to be supported.
Turbo Mode	Enabled[Default], Disabled	Enable/Disable processor Turbo Mode (requires EMTTM enabled too). AUTO means enabled, unless max turbo ratio is bigger than 16 – SKL a0 W/A.
C States	Enabled[Default], Disabled	Enable/Disable CPU Power Management. Allows CPU to go to C states when it’s not 100291697032tilized.

3.6.2.2.1.1 View/Configure Turbo Options

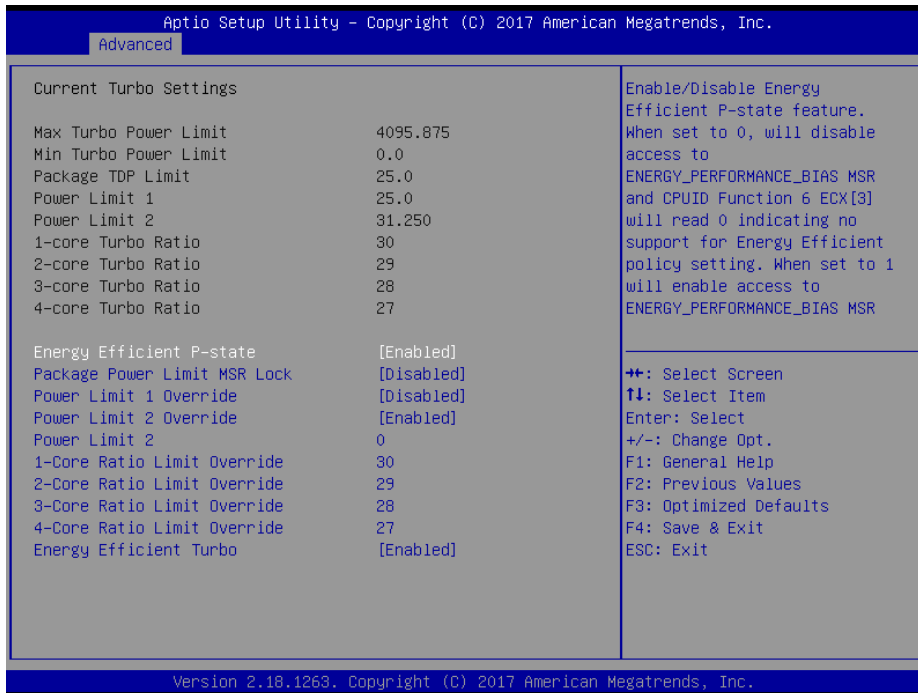

Item	Option	Description
Energy Efficient P-state	Enabled[Default], Disabled	Enable/Disable Energy Efficient P-state feature. When set to 0, will disable access to ENERGY_PERFORMANCE_BIAS MSR and CPUID Function 6 ECX[3] will read 0 indicating no support for Energy Efficient policy setting. When set to 1 will enable access to ENERGY_PERFORMANCE_BIAS MSR 1B0h and CPUID Function 6 ECX[3] will read 1 indicating Energy Efficient policy setting is.
Package Power Limit MSR Lock	Disabled[Default] Enabled	Enable/Disable locking of Package Power Limit settings. When enabled, PACKAGE_POWER_LIMIT MSR will be locked and a reset will be required to unlock the register.
Power Limit 1 Override	Disabled[Default] Enabled	Enable/Disable Power Limit 1 override. If this option is disabled, BIOS will program the default values for Power Limit 1 and Power Limit 1 Time Window.
Power Limit 2 Override	Disabled Enabled[Default]	Enable/Disable Power Limit 2 override. If this option is disabled, BIOS will program the default values for Power Limit 2.
Power Limit 2	0	Power Limit 2 value in Milli Watts. BIOS will round to the nearest 1/8W when programming. If the value is 0, BIOS will program this value as 1.25*TDP. For

ESM-KBLA User's Manual

		12.50W, enter 12500. Processor applies control policies such that the package power does not exceed this limit.
1-Core Ratio Limit Override	0-83	1-Core Ratio Limit with range 0 to 83. The Minimum range may vary between Processors. This 1-Core Ratio Limit Must be greater than or equal to 2-Core ratio Limit, 3-Core Ratio Limit, 4-Core Ratio Limit.
2-Core Ratio Limit Override	0-83	2-Core Ratio Limit with range 0 to 83. The Minimum range may vary between Processors. This 2-Core Ratio Limit Must be Less than or equal to 1-Core Ratio Limit.
3-Core Ratio Limit Override	0-83	4-Core Ratio Limit with range 0 to 83. The Minimum range may vary between Processors. This 4-Core Ratio Limit Must be Less than or equal to 1-Core Ratio Limit.
4-Core Ratio Limit Override	0-83	1-Core Ratio Limit with range 0 to 83. The Minimum range may vary between Processors. This 1-Core Ratio Limit Must be greater than or equal to 2-Core ratio Limit, 3-Core Ratio Limit, 4-Core Ratio Limit.
Energy Efficient Turbo	Disabled, Enabled[Default]	Enable/Disable Energy Efficient Turbo Feature. This feature will opportunistically lower the turbo frequency to increase efficiency. Recommended only to disable in overclocking situations where turbo frequency must remain constant. Otherwise, leave enabled.

3.6.2.2.2 GT – Power Management Control

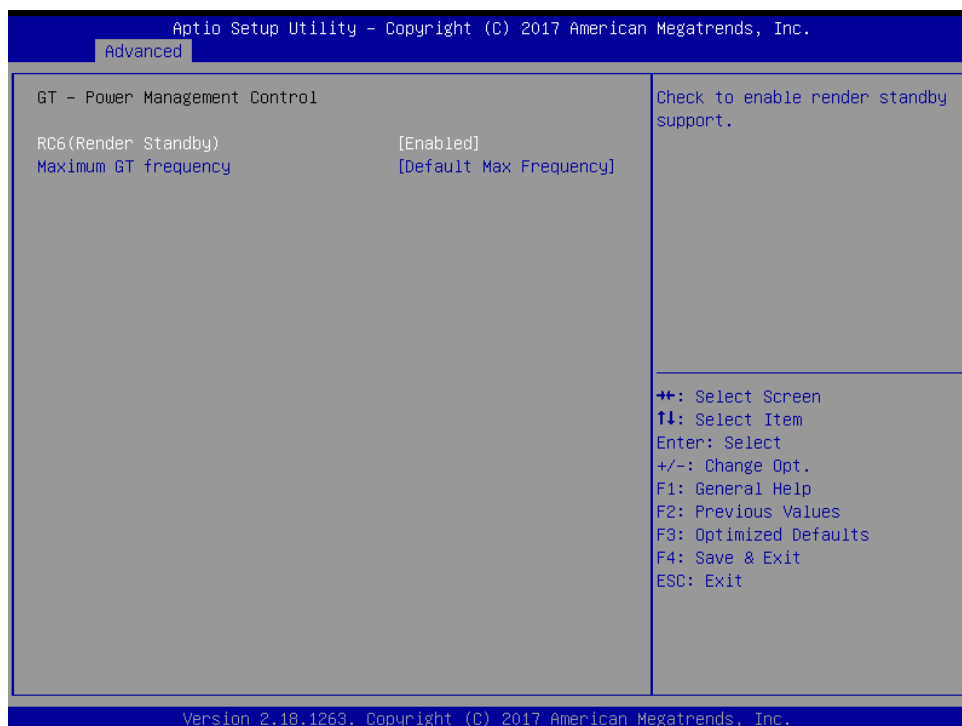

Item	Option	Description
RC6(Render Standby)	Enabled[Default], Disabled	Check to enable render standby support.
Maximum GT frequency	Default Max Frequency[Default] 100Mhz/150Mhz/200Mhz/250Mhz/300Mhz /350Mhz/400Mhz/450Mhz/500Mhz/550Mhz /600Mhz/650Mhz/700Mhz/750Mhz/800Mhz /850Mhz/900Mhz/950Mhz/1000Mhz/1050Mhz /1100Mhz/1150Mhz/1200Mhz	Auto Updated.

3.6.2.3 PCH-FW Configuration

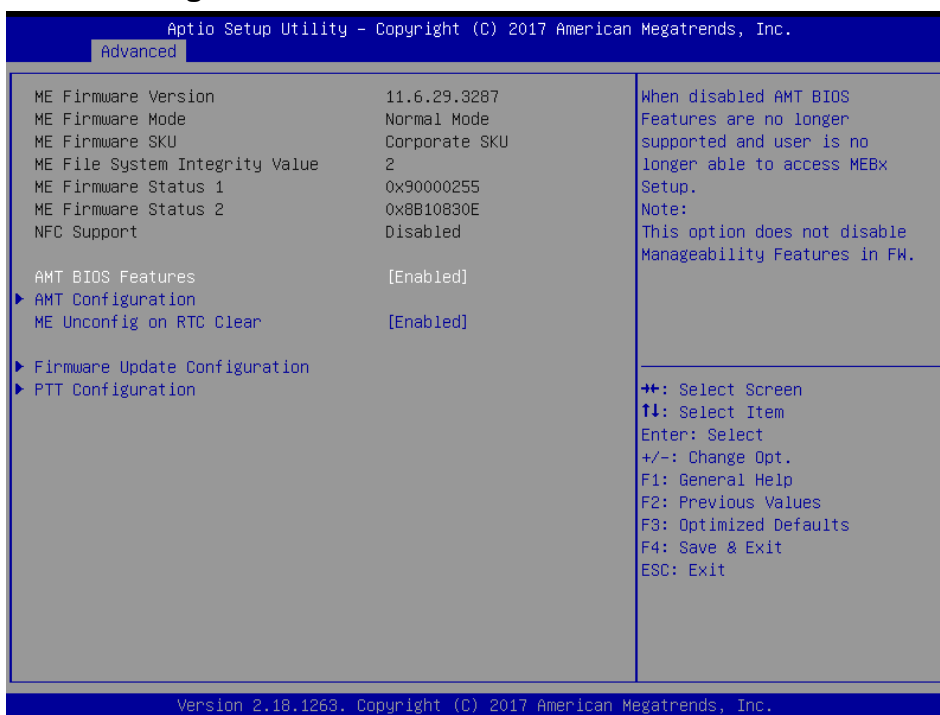

Item	Options	Description
AMT BIOS Features	Disabled, Enabled[Default]	When disabled AMT BIOS Features are no longer supported and user is no longer able to access MEXb Setup. Note: This option does not disable Manageability Features in FW.
ME Unconfig on RTC Clear	Disabled, Enabled[Default]	When Disabled ME will not be unconfigured on RTC Clear.

ESM-KBLA User's Manual

3.6.2.3.1 AMT Configuration

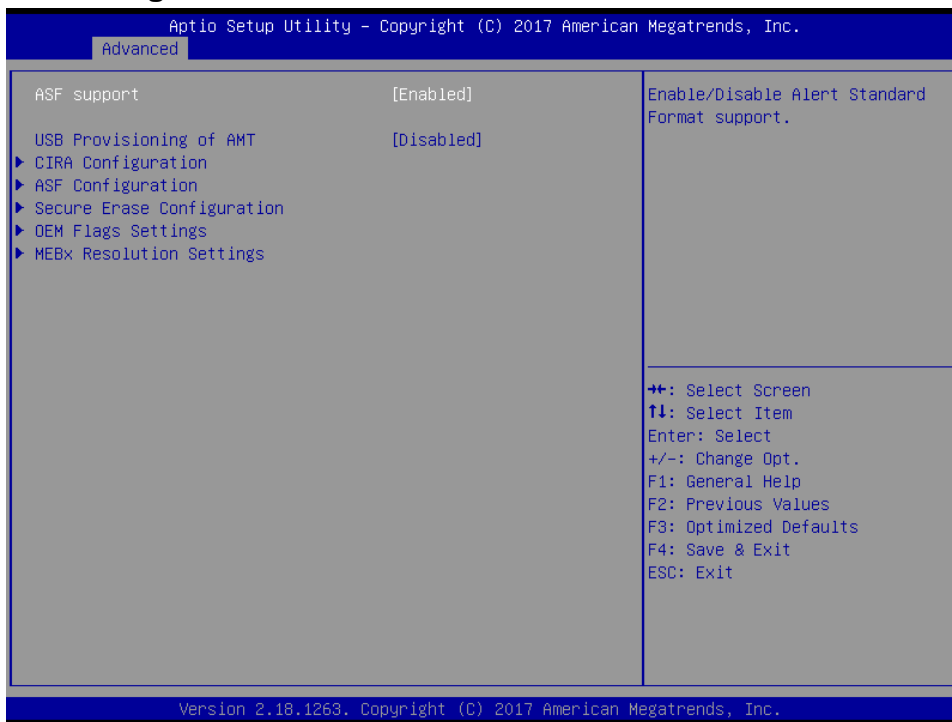

Item	Option	Description
ASF support	Disabled, Enabled[Default]	Enable/Disable Alert Standard Format support.
USB Provisioning of AMT	Disabled[Default], Enabled	Enable/Disable of AMT USB Provisioning.

3.6.2.3.1.1 CIRA Configuration

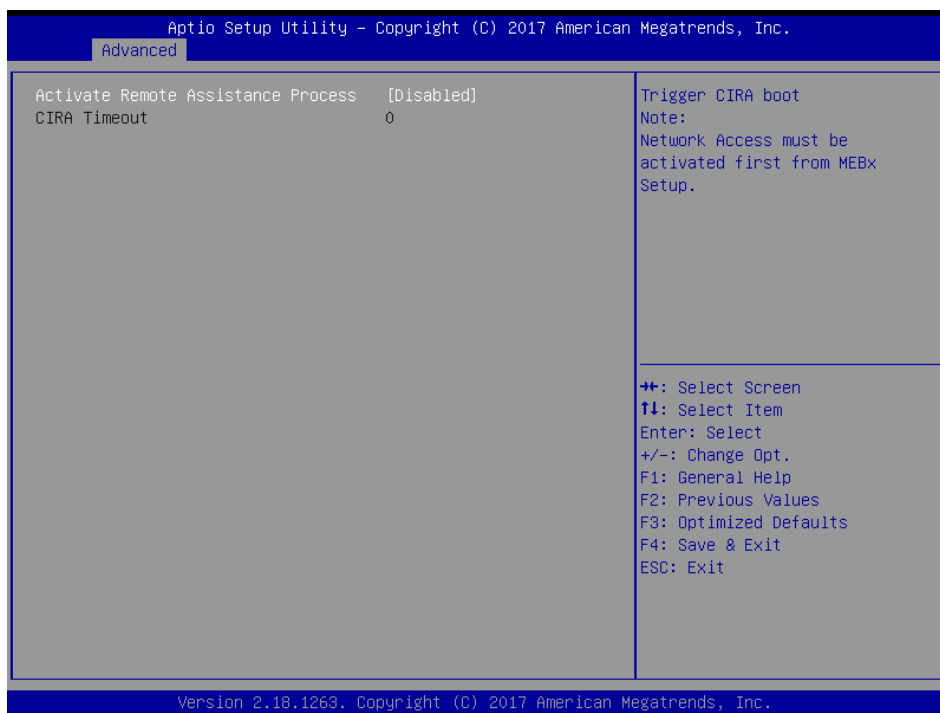

Item	Description
Activate Remote Assistance Process	Trigger CIRA boot. Note: Network Access must be activated first from MEBx Setup.

3.6.2.3.1.2 ASF Configuration

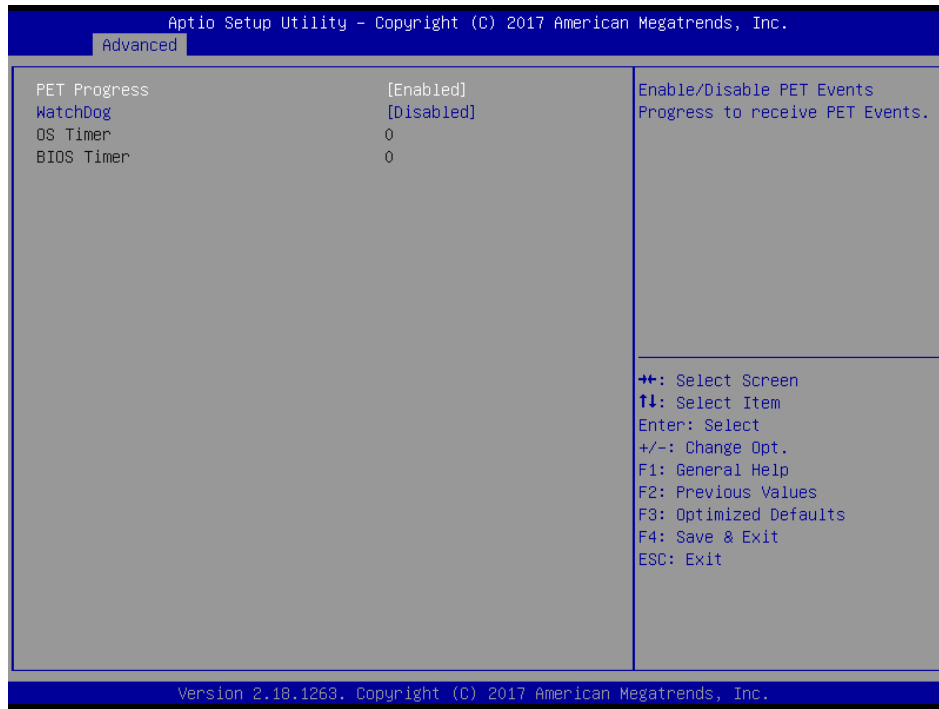

Item	Option	Description
PET Progress	Disabled, Enabled[Default]	Enable/Disable PET Events Progress to receive PET Events.
WatchDog	Disabled[Default], Enabled	Enable/Disable WatchDog Timer.

ESM-KBLA User's Manual

3.6.2.3.1.3 Secure Erase Configuration

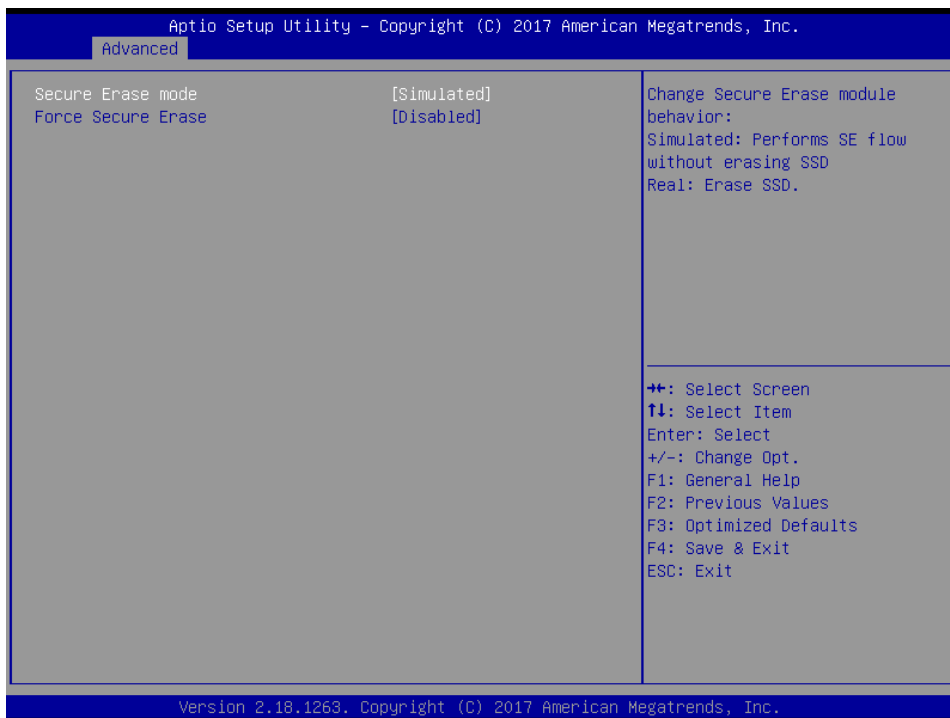

Item	Option	Description
Secure Erase mode	Simulated [Default] Real	Change Secure Erase module behavior: Simulated: Performs SE flow without erasing SSD Real: Erase SSD.
Force Secure Erase	Disabled [Default] , Enabled	Force Secure Erase on next boot.

3.6.2.3.1.4 OEM Flags Settings

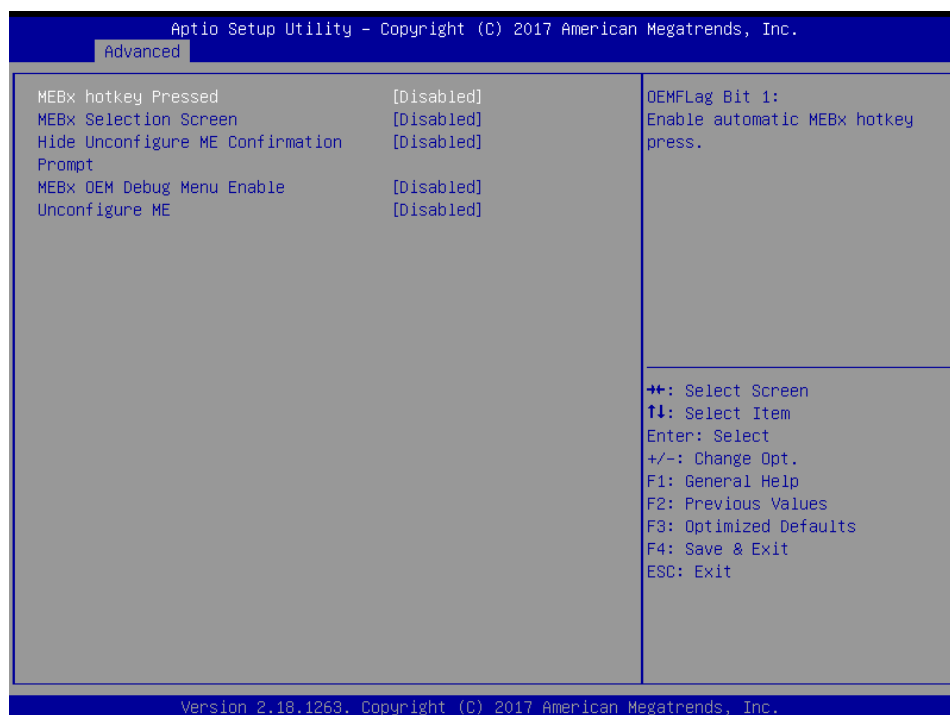

Item		Description
MEBx hotkey Pressed	Disabled[Default], Enabled	OEMFlag Bit 1: Enable automatic MEBx hotkey press.
MEBx Selection Screen	Disabled[Default], Enabled	OEMFlag Bit 2: Enable MEBx selection screen with 2 options: Press 1 to enter ME Configuration Screens Press 2 to initiate a remote connection Note: Network Access must be activated from MEBx Setup for this screen to be displayed.
Hide Unconfigure ME Confirmation	Disabled[Default], Enabled	OEMFlag Bit 6: Hide Unconfigure ME confirmation prompt when attempting ME unconfiguration.
MEBx OED Debug Menu Enable	Disabled[Default], Enabled	OEMFlag Bit 14: Enable OEM debug menu in MEBx.
Unconfigure ME	Disabled[Default], Enabled	OEMFlag Bit 15: Unconfigure ME with resetting MEBx password to default.

3.6.2.3.1.5 MEBx Resolution Settings

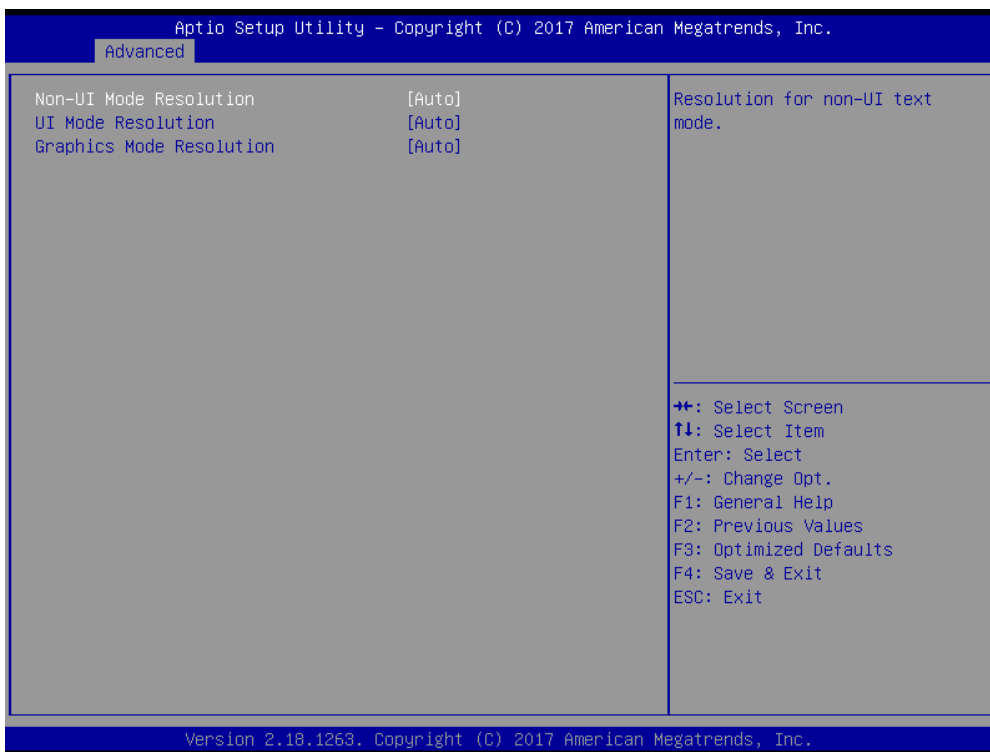

Item		Description
Non-UI Mode Resolution	Auto[Default], 80x25 100x31	Resolution for non-UI text mode.
UI Mode Resolution	Auto[Default], 80x25 100x31	Resolution for UI text mode.
Graphics Mode Resolution	Auto[Default], 640x480	Resolution for graphics mode.

ESM-KBLA User's Manual

	800x600 1024x768	
--	---------------------	--

3.6.2.3.2 Firmware Update Configuration

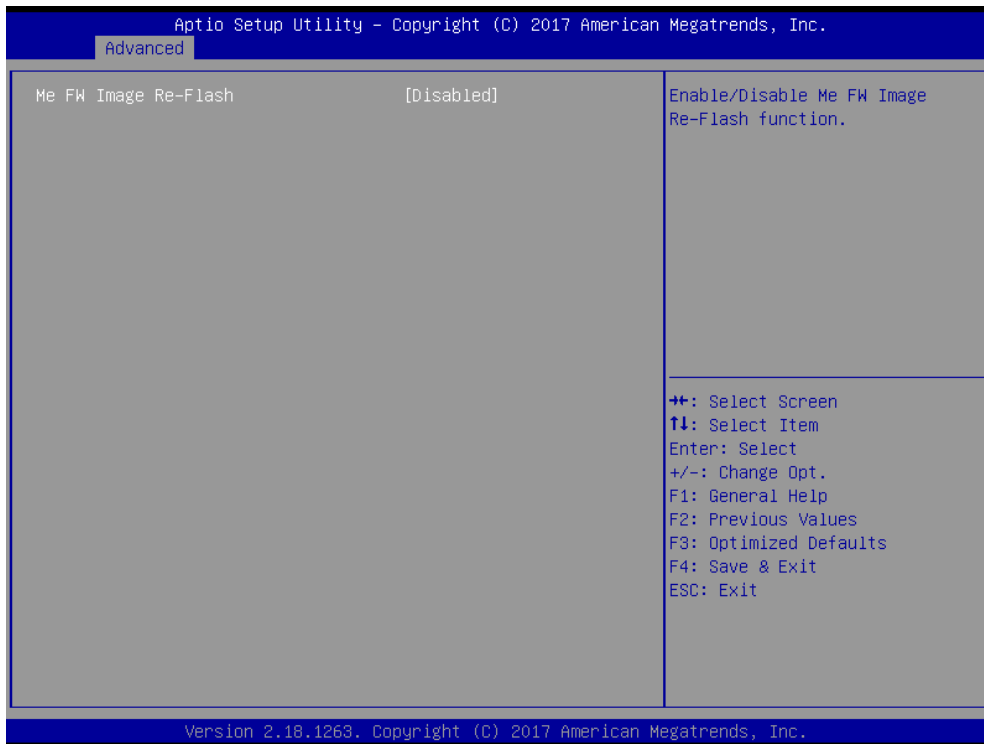

Item	Option	Description
ME FW Image Re-Flash	Disabled [Default] , Enabled	Enable/Disable Me FW Image Re-Flash function.

3.6.2.3.3 PTT Configuration

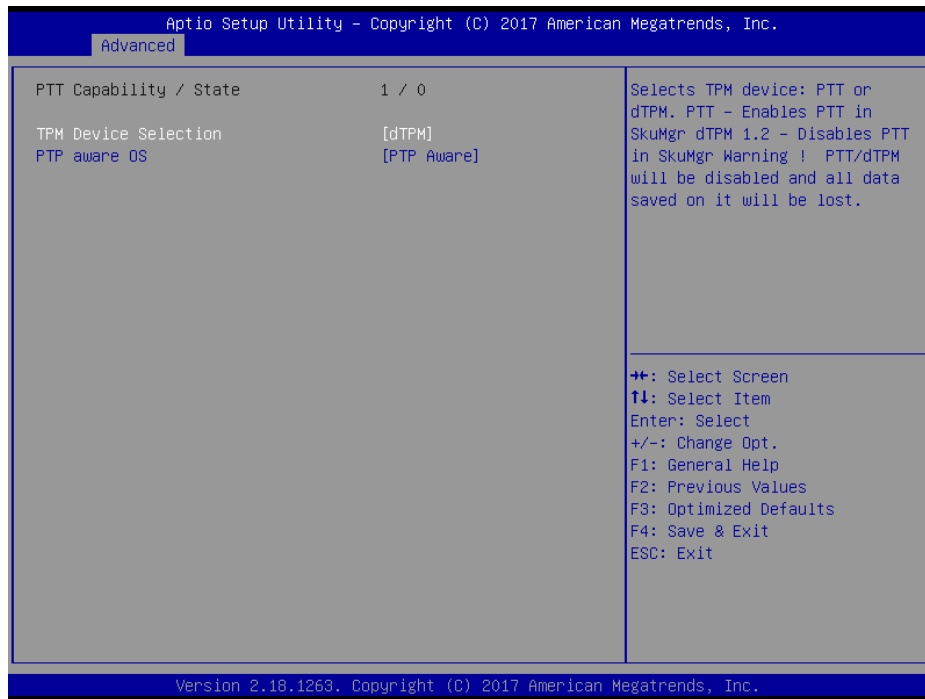

Item	Option	Description
TPM Device Selection	dTPM[Default], PTT	Selects TPM device: PTT or dTPM. PTT – Enables PTT in SkuMgr dTPM 1.2 – Disables PTT in SkuMgr Warning! PTT/dTPM will be disabled and all data saved on it will be lost.
PTP aware OS	PTP Aware[Default] Not PTP Aware	Select whether or not the OS you will boot to will be PTP aware.

ESM-KBLA User's Manual

3.6.2.4 Trusted Computing

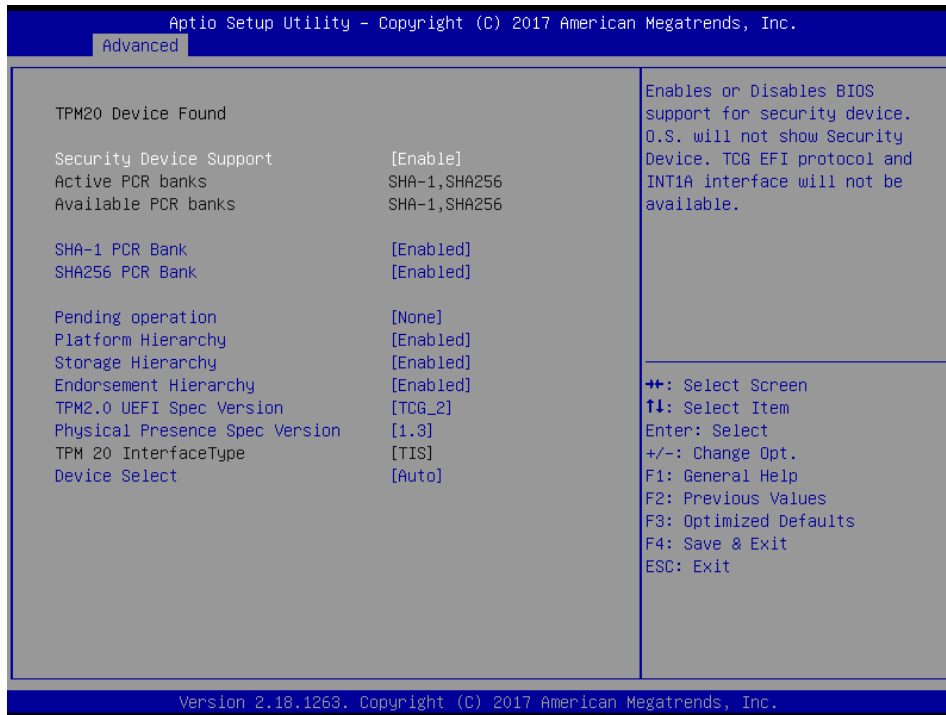

Item	Options	Description
Security Device Support	Disable, Enable[Default]	Enables or Disables BIOS support for security device. O.S. will not show Security Device. TCG EFI protocol and INT1A interface will not be available.
SHA-1 PCR Bank	Disabled Enabled[Default],	Enable or Disable SHA-1 PCR Bank.
SHA256 PCR Bank	Disabled Enabled[Default],	Enable or Disable SHA256 PCR Bank.
Pending operation	None[Default], TPM Clear	Schedule an Operation for the Security Device. NOTE: Your Computer will reboot during restart in order to change State of Security Device.
Platform Hierarchy	Disabled Enabled[Default],	Enable or Disable Platform Hierarchy.
Storage Hierarchy	Disabled Enabled[Default],	Enable or Disable Storage Hierarchy.
Endorsement Hierarchy	Disabled Enabled[Default],	Enable or Disable Endorsement Hierarchy.
TPM2.0 UEFI Spec Version	TCG_1_2 TCG_2[Default],	Select the TCG2 Spec Version Support, TCG_1_2: the Compatible mode for Win8/Win10, TCG_2: Support new TCG2 protocol and event format for Win10 or later.
Physical Presence Spec Version	1.2 1.3[Default],	Select to Tell O.S. to support PPI Spec Version 1.2 or 1.3. Note some HCK tests might not support 1.3.

<p>Device Select</p>	<p>TPM 1.2 TPM 2.0 Auto[Default],</p>	<p>TPM 1.2 will restrict support to TPM 1.2 devices, TPM 2.0 will restrict support to TPM 2.0 devices, Auto will support both with the default set to TPM 2.0 devices if not found, TPM 1.2 devices will be enumerated.</p>
-----------------------------	--	---

3.6.2.5 ACPI Settings

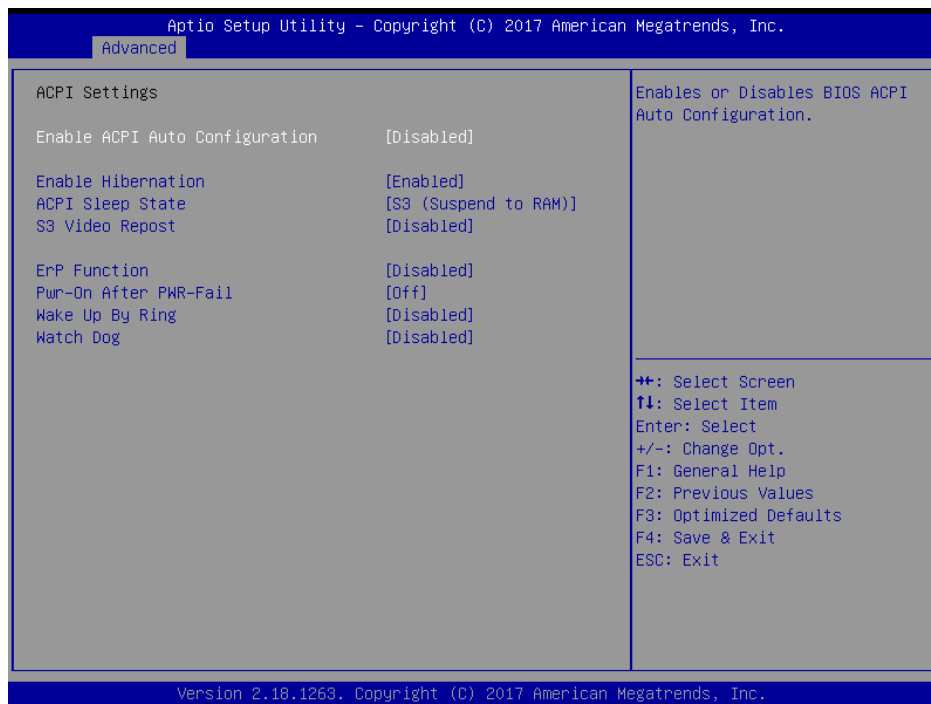

Item	Options	Description
<p>Enable ACPI Auto Configuration</p>	<p>Disabled[Default], Enabled</p>	<p>Enables or Disables BIOS ACPI Auto Configuration.</p>
<p>Enable Hibernation</p>	<p>Disabled Enabled[Default],</p>	<p>Enables or Disables System ability to Hibernate (OS/S4 Sleep State). This option may not be effective with some OS.</p>
<p>ACPI Sleep State</p>	<p>Suspend Disabled, S3 (Suspend to RAM) [Default]</p>	<p>Select the highest ACPI sleep state the system will enter when the SUSPEND button is pressed.</p>
<p>S3 Video Repost</p>	<p>Disabled[Default], Enabled</p>	<p>Enable or Disable S3 Video Repost.</p>
<p>ErP Function</p>	<p>Disabled[Default], Enabled</p>	<p>ErP Function (Deep S5).</p>
<p>Pwr-On After PWR-Fail</p>	<p>Off[Default] On Last state</p>	<p>Select the power station after power failure.</p>
<p>Wake Up By Ring</p>	<p>Disabled[Default], Enabled</p>	<p>System wake up by ring (from S3~S5).</p>

ESM-KBLA User's Manual

Watch Dog	Disabled[Default],	Select Watch Dog Timer (WDT) Mode.
	30 sec	
	40 sec	
	50 sec	
	1 min	
	2 min	
	10 min 30 min	

3.6.2.6 NCT6106D Super IO Configuration

You can use this item to set up or change the NCT6106D Super IO configuration for serial ports. Please refer to 3.6.2.6.1~ 3.6.2.6.3 for more information.



Item	Description
Serial Port 1 Configuration	Set Parameters of Serial Port 1 (COMA).
Serial Port 2 Configuration	Set Parameters of Serial Port 2 (COMB).
Parallel Port Configuration	Set Parameters of Parallel Port (LPT/LPTE).

3.6.2.6.1 Serial Port 1 Configuration

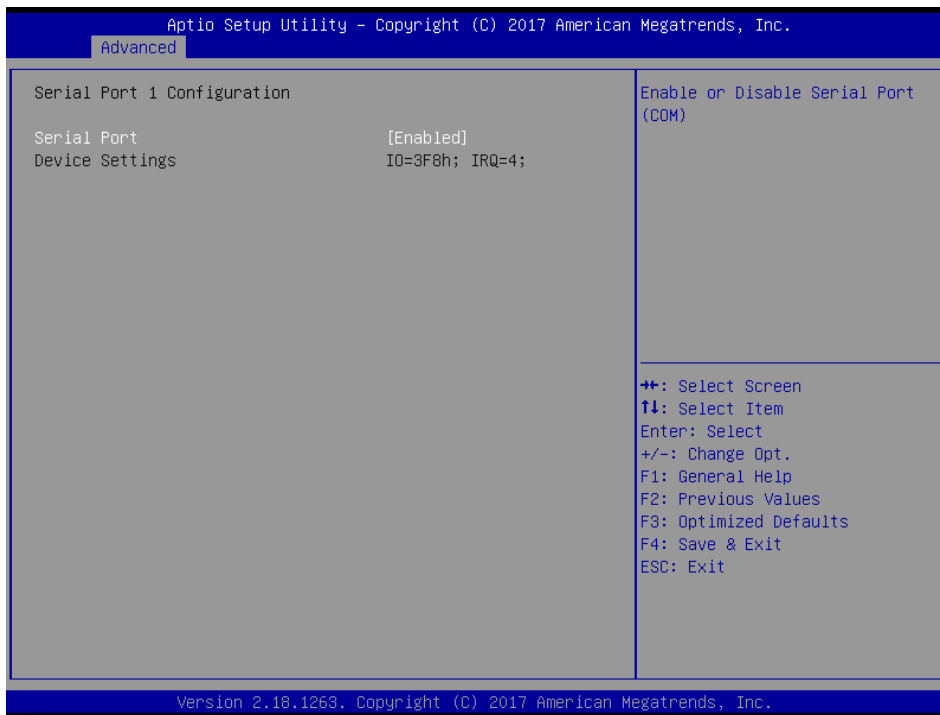

Item	Option	Description
Serial Port	Enabled[Default], Disabled	Enable or Disable Serial Port (COM).

3.6.2.6.2 Serial Port 2 Configuration

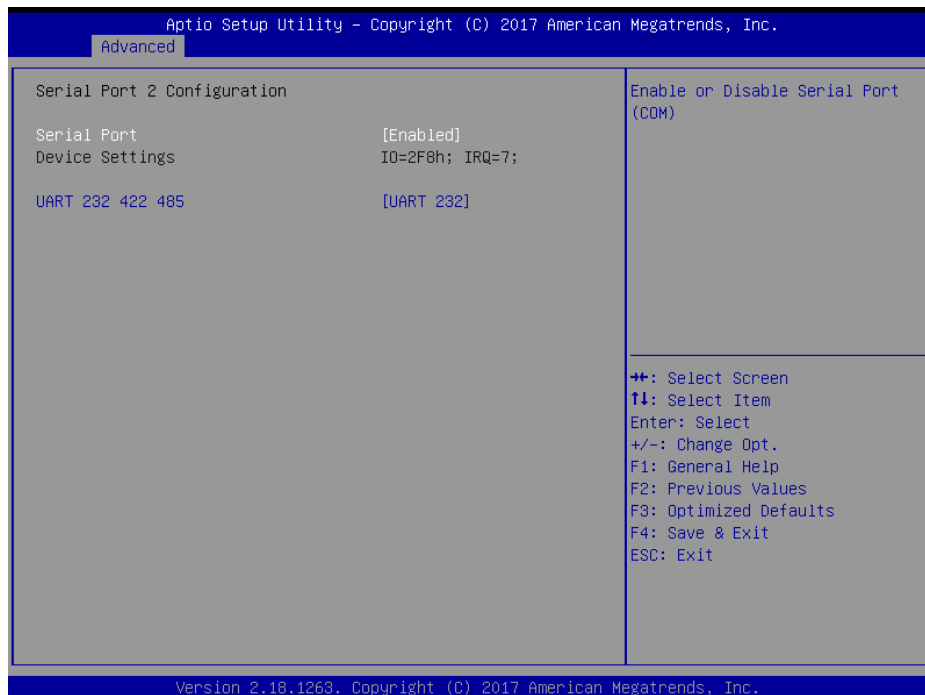

ESM-KBLA User's Manual

Item	Option	Description
Serial Port	Enabled[Default], Disabled	Enable or Disable Serial Port (COM).
UART 232 422 485	UART 232[Default] UART 422 UART 485	Change the Serial Port as RS232/422/485.

3.6.2.6.3 Parallel Port Configuration

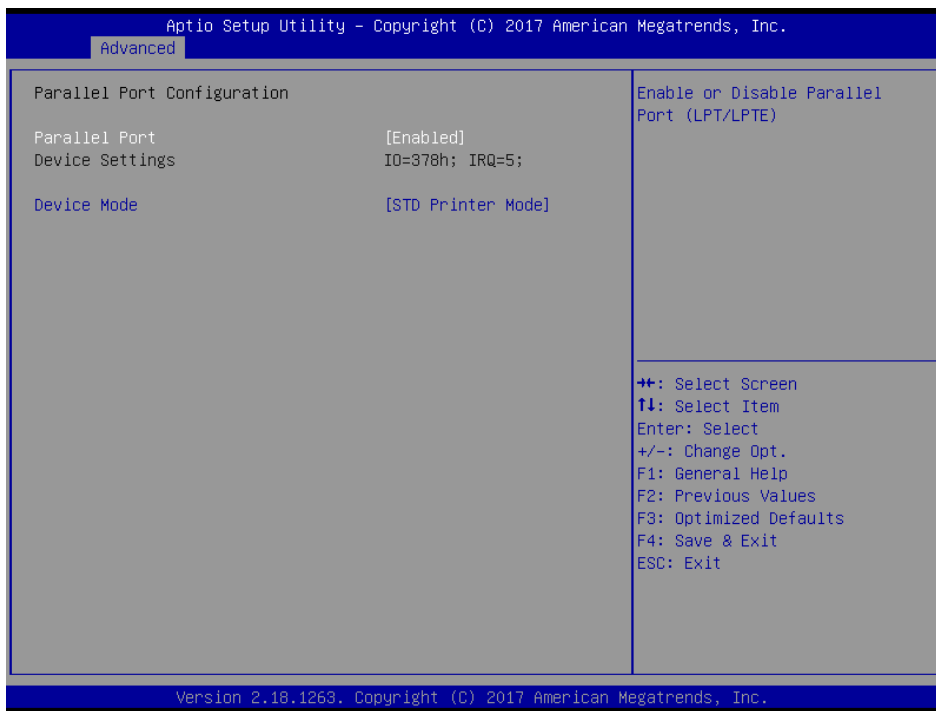

Item	Option	Description
Parallel Port	Enabled[Default], Disabled	Enable or Disable Parallel Port (LPT/LPTE).
Device Mode	STD Printer Mode[Default] EPP-1.9 and SPP Mode EPP-1.7 and SPP Mode ECP Mode ECP and EPP 1.9 Mode ECP and EPP 1.7 Mode	Change the Printer Port mode.

3.6.2.7 NCT6106D HW Monitor

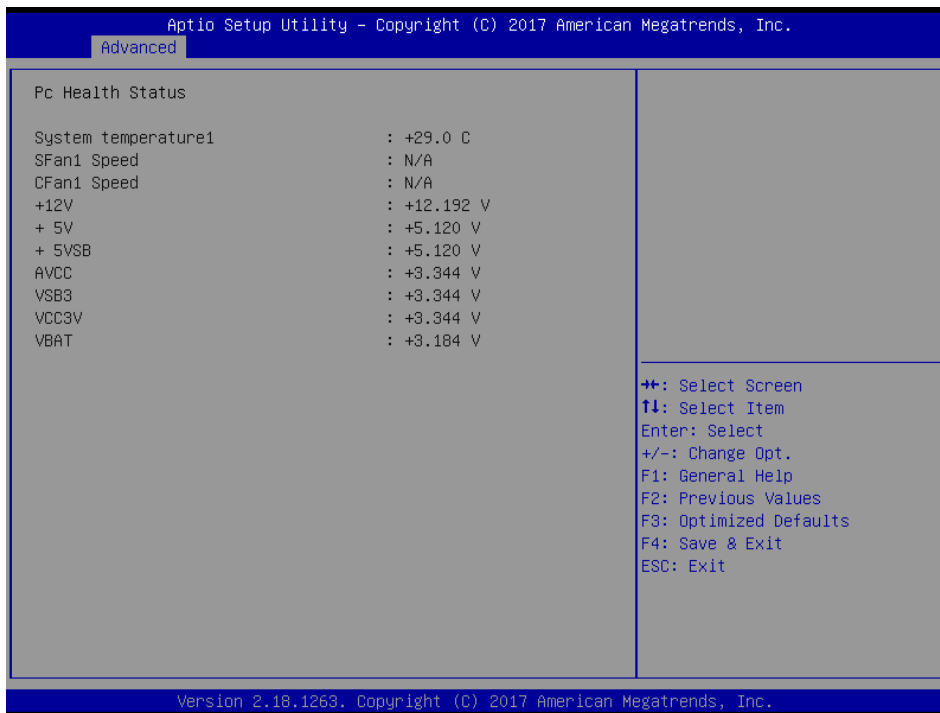

3.6.2.8 IT8528SEC Super IO Configuration

You can use this item to set up or change the IT8528SEC Super IO configuration for serial ports. Please refer to 3.6.2.8.1~ 3.6.2.8.2 for more information.

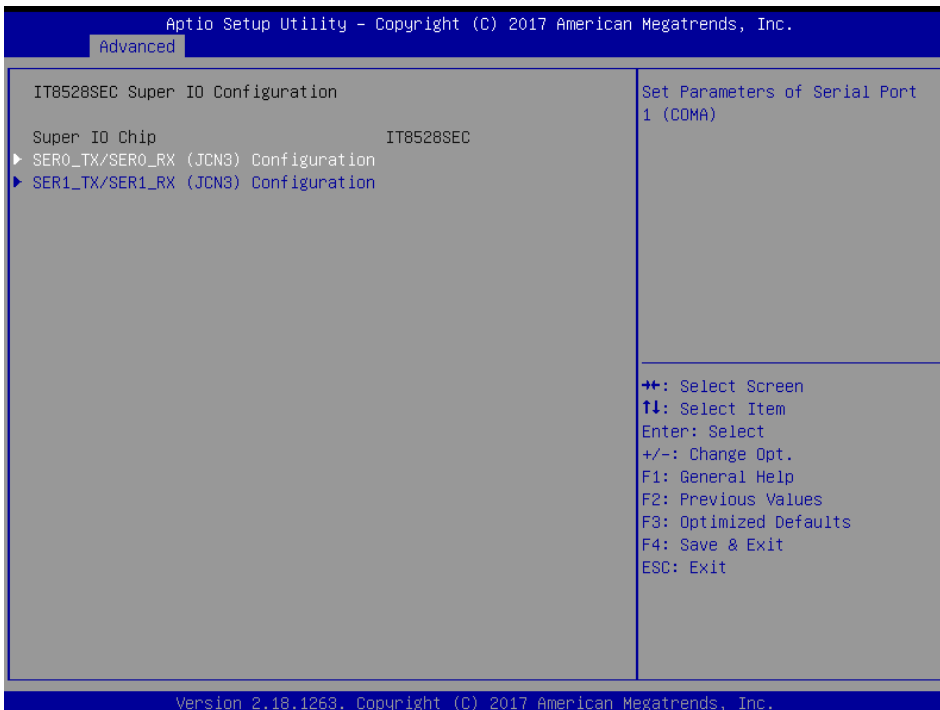

3.6.2.8.1 SER0_TX/SER0_RX (JCN3) Configuration

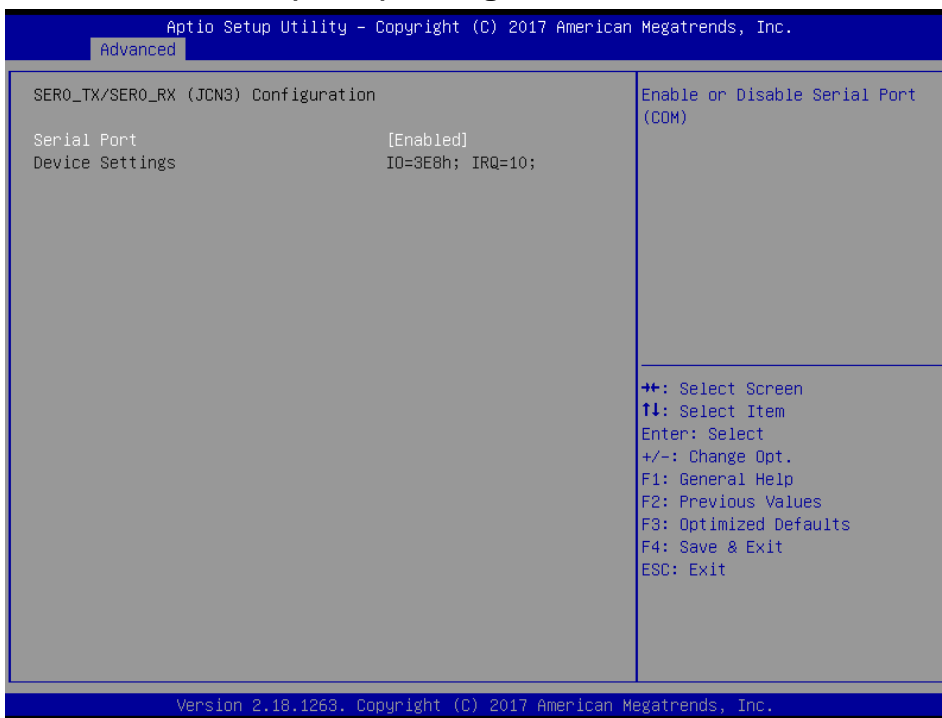

Item	Option	Description
Serial Port	Enabled[Default], Disabled	Enable or Disable Serial Port (COM).

3.6.2.8.2 SER1_TX/SER1_RX (JCN3) Configuration

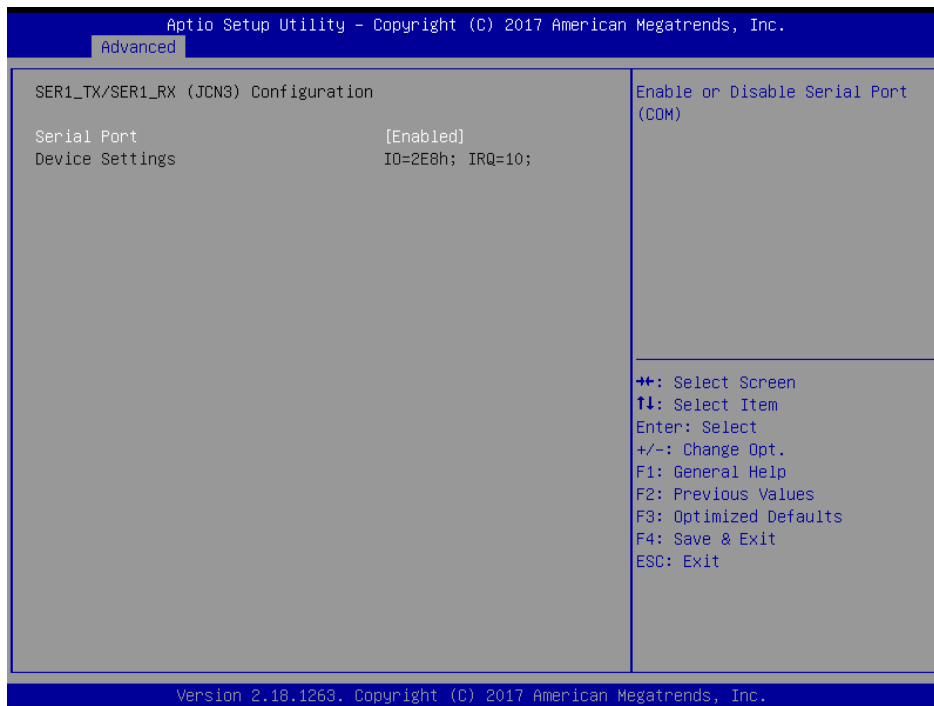

Item	Option	Description
Serial Port	Enabled[Default], Disabled	Enable or Disable Serial Port (COM).

3.6.2.9 H/W Monitor

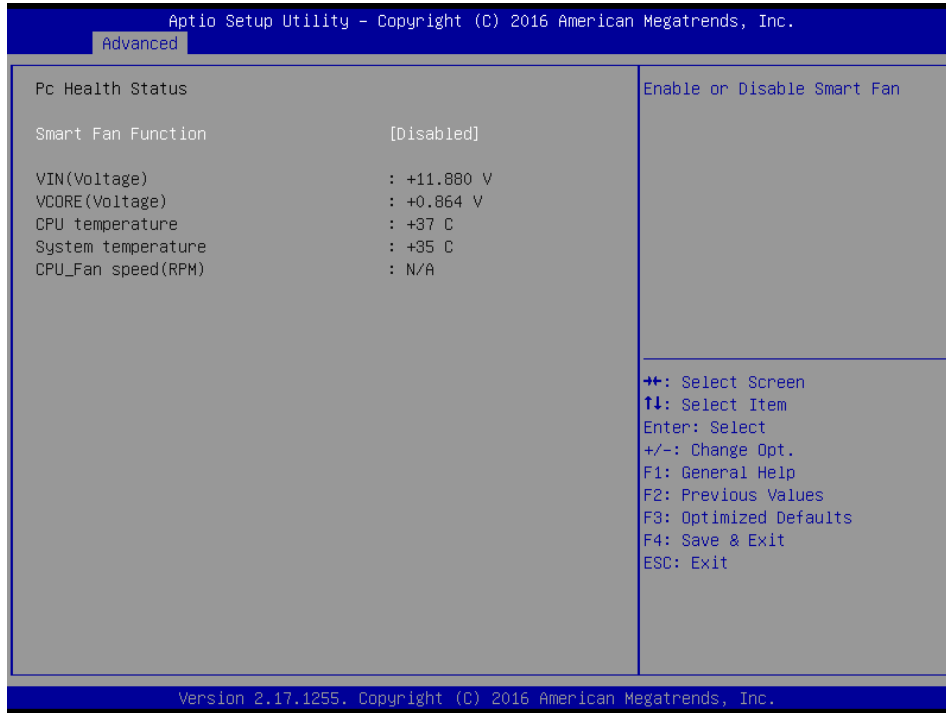

Item	Options	Description
Smart Fan Function	Enabled, Disabled[Default]	Enables or Disables Smart Fan.

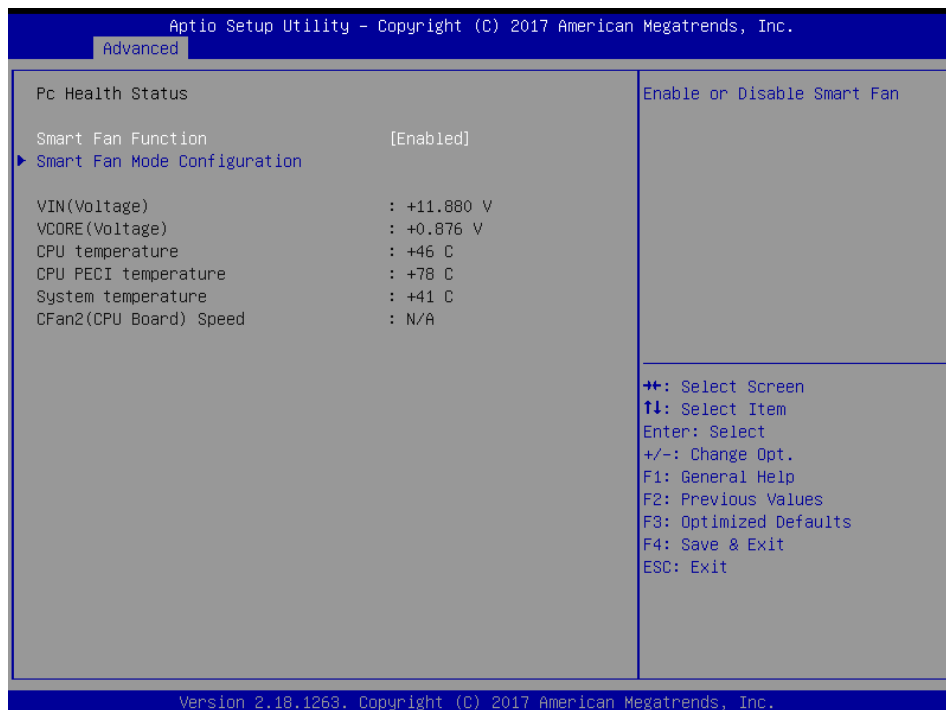

ESM-KBLA User's Manual

Item	Options	Description
Smart Fan Function	Enabled[Default], Disabled	Enables or Disables Smart Fan.

3.6.2.9.1 Smart Fan Mode Configuration

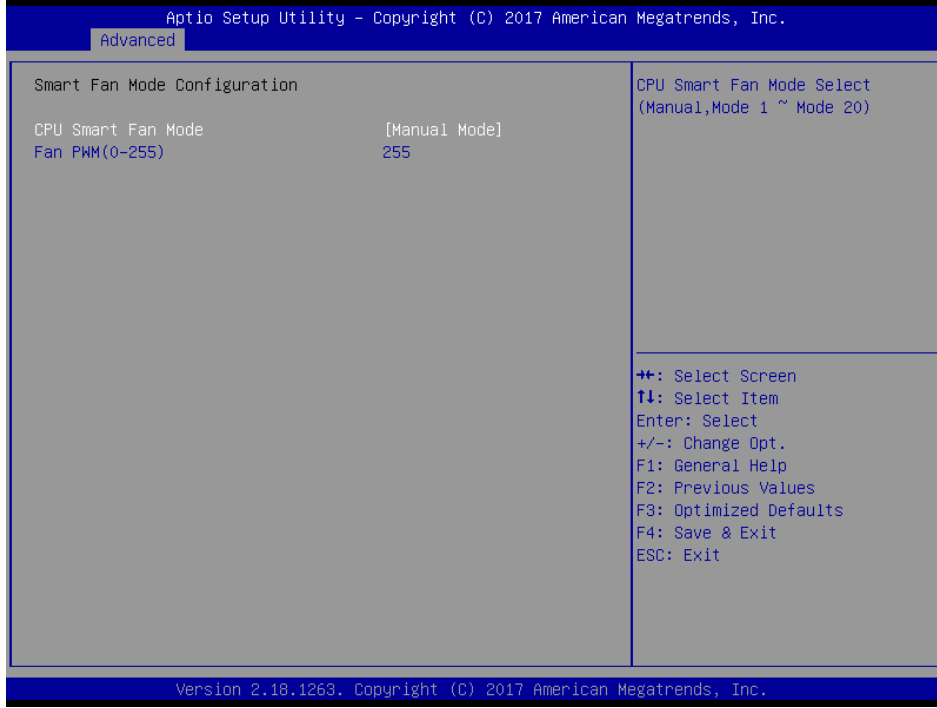

Item	Option	Description
CPU Smart Fan Mode	Manual Mode[Default], Mode 01/02/03/04/05 /06/07/08/09/10 /11/12/13/14/15 /16/17/18/19/20	CPU Smart Fan Mode Select (Manual, Mode 1~Mode 20).
Fan PWM (0-255)	0-255[Default]	Fan PWM duty (0-255).

3.6.2.10 S5 RTC Wake Settings

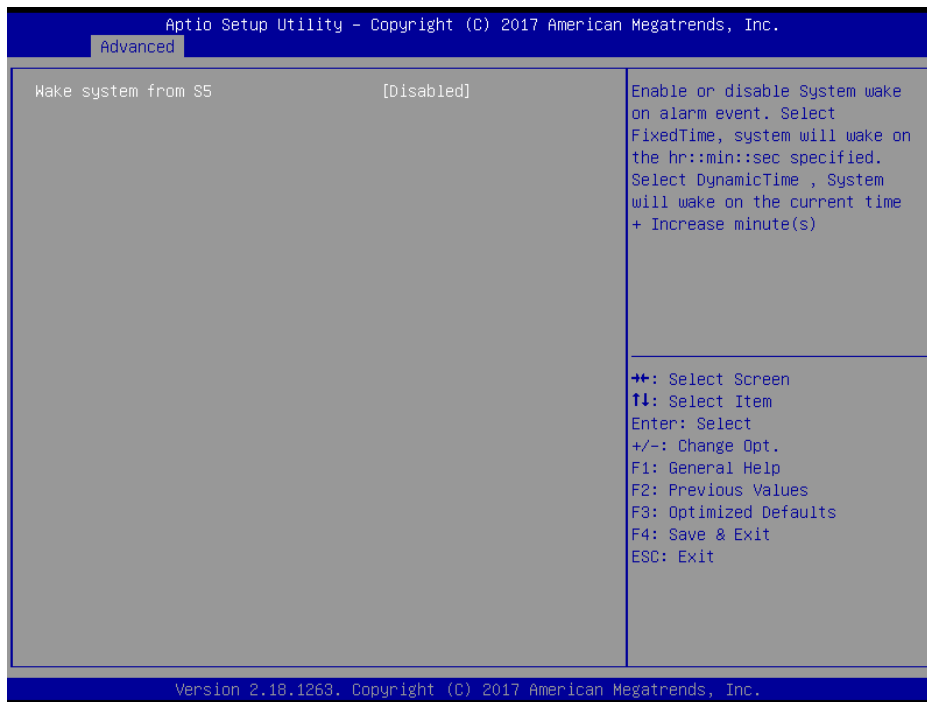

Item	Options	Description
Wake system from S5	Disabled[Default], Fixed Time Dynamic Time	Enable or disable System wake on alarm event. Select Fixed Time, system will wake on the hr::min::sec specified. Select Dynamic Time, System will wake on the current time + Increase minute(s).

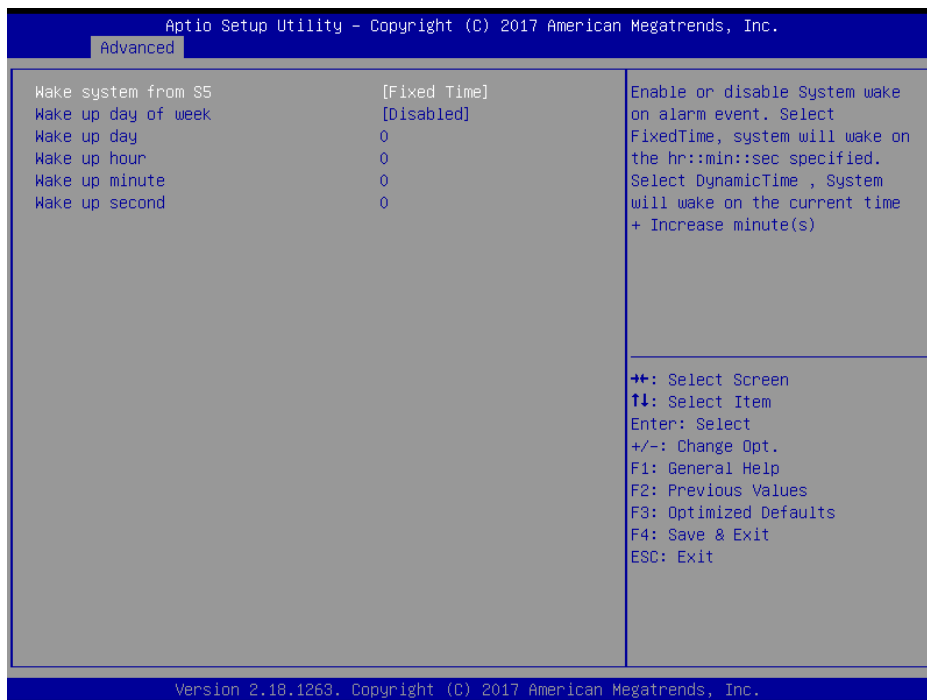

ESM-KBLA User's Manual

Item	Options	Description
Wake system from S5	Disabled, Fixed Time[Default] Dynamic Time	Enable or disable System wake on alarm event. Select Fixed Time, system will wake on the hr::min::sec specified. Select Dynamic Time, System will wake on the current time + Increase minute(s).
Wake up day of week	Disabled[Default] Monday-Friday Monday-Saturday	Wake up day of week. (Monday-Friday) or (Monday-Saturday).
Wake up day	1-31	Select 0 for daily system wake up 1-31 for which day of the month that you would like the system to wake up.
Wake up hour	0-23	Select 0-23 For example enter 3 for 3am and 15 for 3pm.
Wake up minute	0-23	Select 0-23 For example enter 3 for 3am and 15 for 3pm.
Wake up second	0-23	Select 0-23 For example enter 3 for 3am and 15 for 3pm.

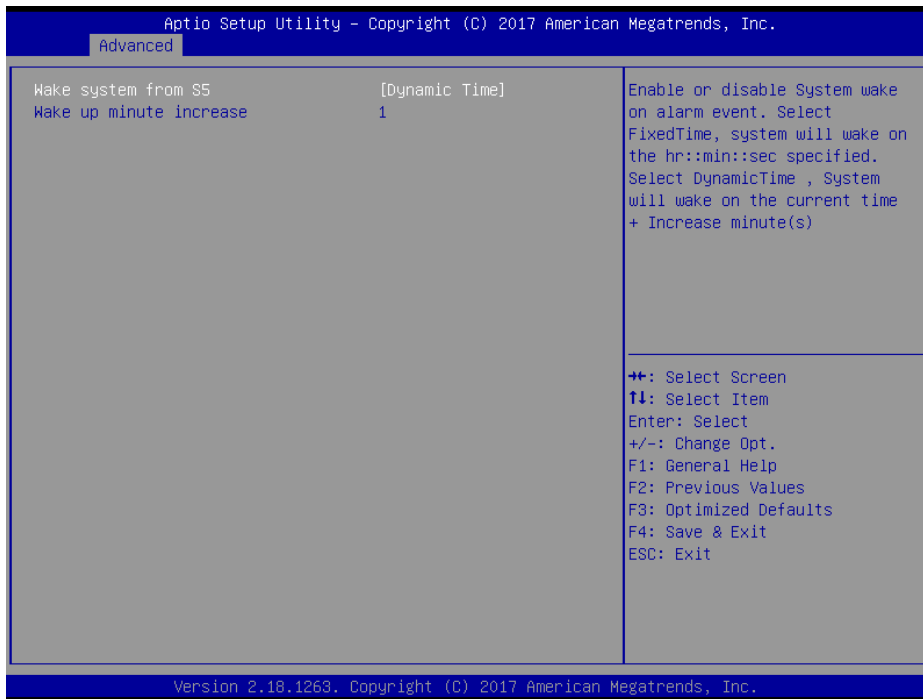

Item	Options	Description
Wake system from S5	Disabled, Fixed Time Dynamic Time[Default]	Enable or disable System wake on alarm event. Select Fixed Time, system will wake on the hr::min::sec specified. Select Dynamic Time, System will wake on the current time + Increase minute(s).
Wake up minute increase	1-5	1-5.

3.6.2.11 Serial Port Console Redirection

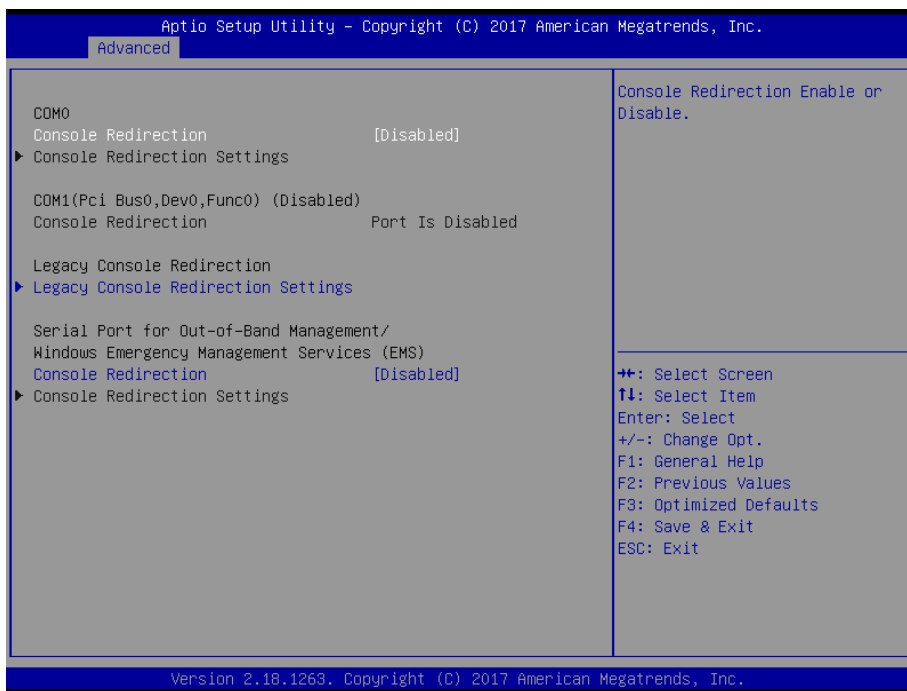

Item	Options	Description
Console Redirection	Disabled[Default], Enabled	Console Redirection Enable or Disable.

3.6.2.11.1 Smart Fan Mode Configuration

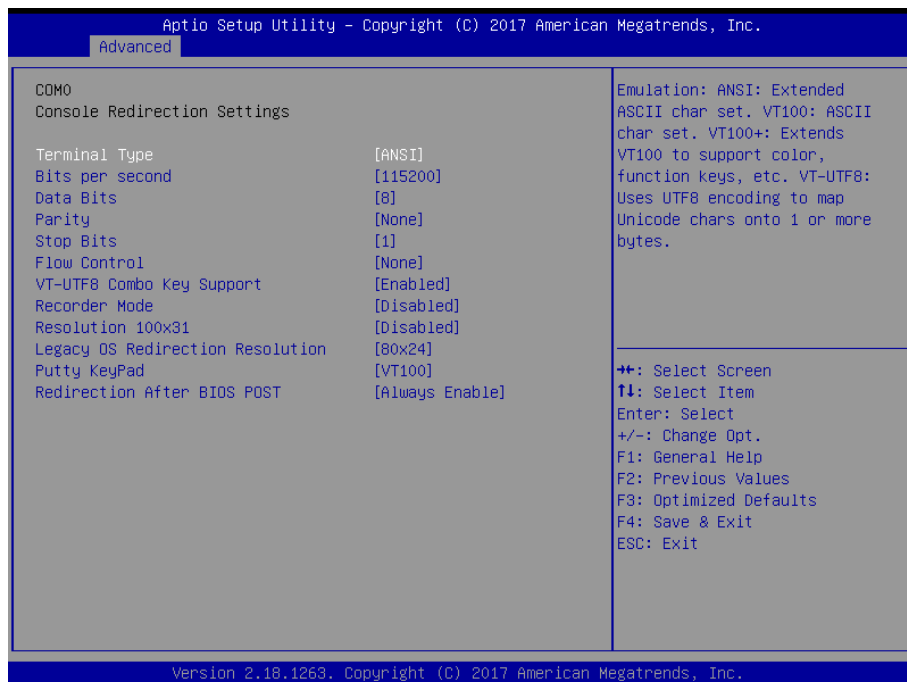

ESM-KBLA User's Manual

Item	Option	Description
Terminal Type	VT100 VT100+ VT-UTF8 ANSI[Default]/	Emulation: ANSI: Extended ASCII char set. VT100: ASCII char set. VT100+: Extends VT100 to support color, function keys, etc. VT-UTF8: Uses UTF8 encoding to map Unicode chars onto 1 or more bytes.
Bits per second	9600 19200 38400 57600 115200[Default]	Select serial port transmission speed. The speed must be matched on the other side. Long or noisy lines may require lower speeds.
Data Bits	7 8[Default]	Data Bits.
Parity	None[Default] Even Odd Mark	A parity bit can be sent with the data bits to detect some transmission errors. Even: parity bit is 0 if the num of 1's in the data bits is even. Odd: parity bit is 0 if num of 1's in the data bits is odd. Mark: parity bit is always 1. Space: Parity bit is always 0. Mark and Space Parity do not allow for error detection. They can be used as an additional data bit.
Stop Bits	1[Default] 2	Stop bits indicate the end of a serial data packet. (A start bit indicates the beginning). The standard setting is 1 stop bit. Communication with slow devices may require more than 1 stop bit.
Flow Control	None[Default] Hardware RTS/CTS	Flow control can prevent data loss from buffer overflow. When sending data, if the receiving buffers are full, a 'stop' signal can be sent to stop the data flow. Once the buffers are empty, a 'start' signal can be sent to re-start the flow. Hardware flow control uses two wires to send start/stop signals.
VT-UTF8 Combo Key Support	Disabled Enabled[Default]	Enable VT-UTF8 Combination Key Support for ANSI/VT100 terminals.
Recorder Mode	Disabled[Default] Enabled	With this mode enabled only text will be sent. This is to capture Terminal data.
Resolution 100x31	Disabled[Default] Enabled	Enables or disables extended terminal resolution.
Legacy OS Redirection Resolution	80x24[Default] 80x25	On Legacy OS, the Number of Rows and Columns supported redirection.
Putty KeyPad	VT100[Default] LINUX XTERM6 SCO ESCN VT400	Select FunctionKey and KeyPad on Putty.

<p>Redirection After BIOS POST</p>	<p>Always Enable[Default] BootLoader</p>	<p>The Settings specify if BootLoader is selected then Legacy console redirection is disabled before booting to Legacy OS. Default value is Always Enable which means Legacy console Redirection is enabled for Legacy OS.</p>
---	--	--

3.6.2.11.2 Console Redirection Settings

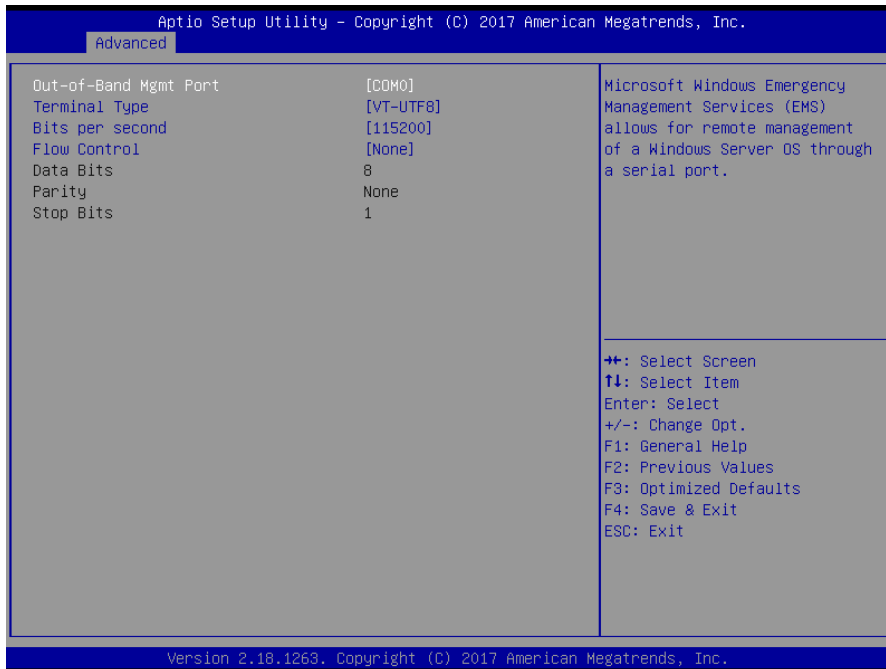

Item	Option	Description
<p>Out-of-Band Mgmt Port</p>	<p>COM0[Default]</p>	<p>Microsoft Windows Emergency Management Services (EMS) allows for remote management of a Windows Server OS through a serial port.</p>
<p>Terminal Type</p>	<p>VT100 VT100+ VT-UTF8[Default] ANSI</p>	<p>VT-UTF8 is the preferred terminal type for out-of-band management. The next best choice is VT100+ and then VT100. See above, in Console Redirection Settings page, for more Help with Terminal Type/Emulation.</p>
<p>Bits per second</p>	<p>9600 19200 57600 115200[Default]</p>	<p>Selects serial port transmission speed. The speed must be matched on the other side. Long or noisy lines may require lower speeds.</p>
<p>Flow Control</p>	<p>None[Default] Hardware RTS/CTS Software Xon/Xoff</p>	<p>Flow control can prevent data loss from buffer overflow. When sending data, if the receiving buffers are full, a 'stop' signal can be sent to stop the data flow. Once the buffers are empty, a 'start' signal can be sent to re-start the flow. Hardware flow control uses two wires to send start/stop signals.</p>

3.6.2.11.3 Console Redirection Settings

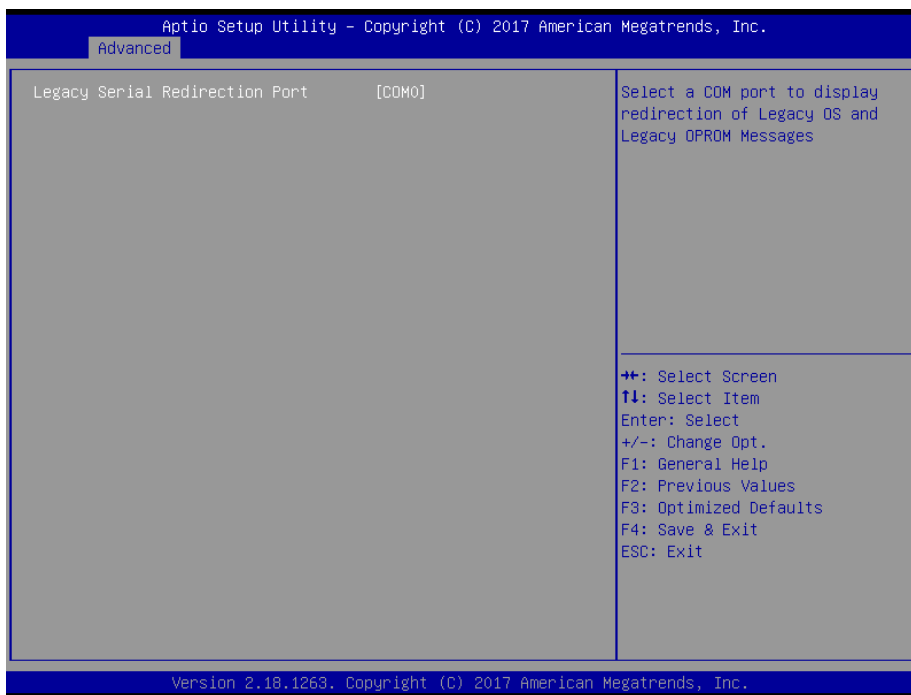

Item	Option	Description
Legacy Serial Redirection Port	COM0[Default]	Select a COM port to display redirection of Legacy OS and Legacy OPRM Messages.

3.6.2.12 Intel TXT Configuration

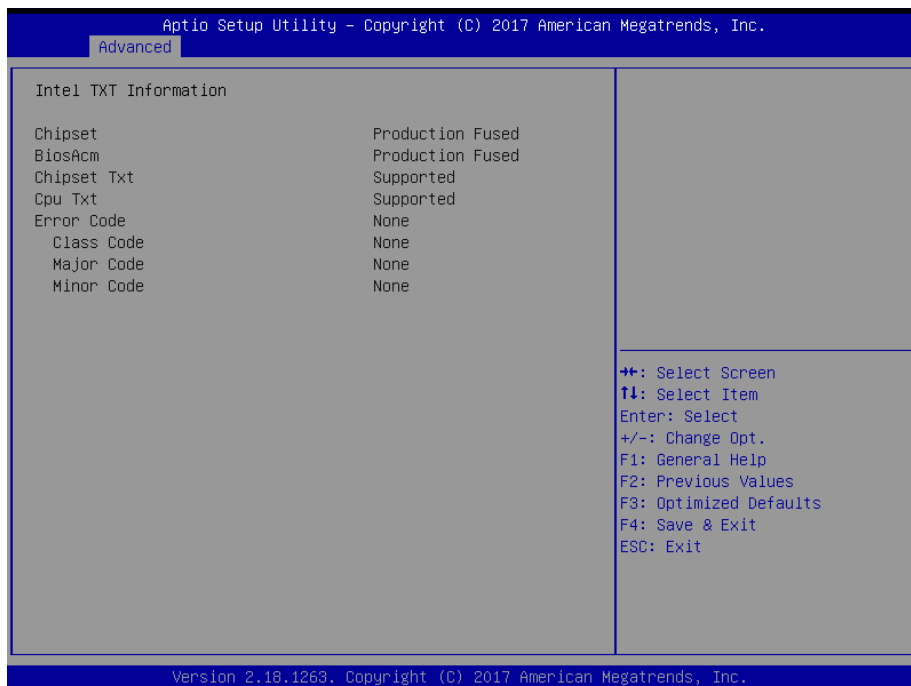

3.6.2.13 Network Stack Configuration



Item	Options	Description
Network Stack	Enabled Disabled[Default]	Enable/Disable UEFI Network Stack.

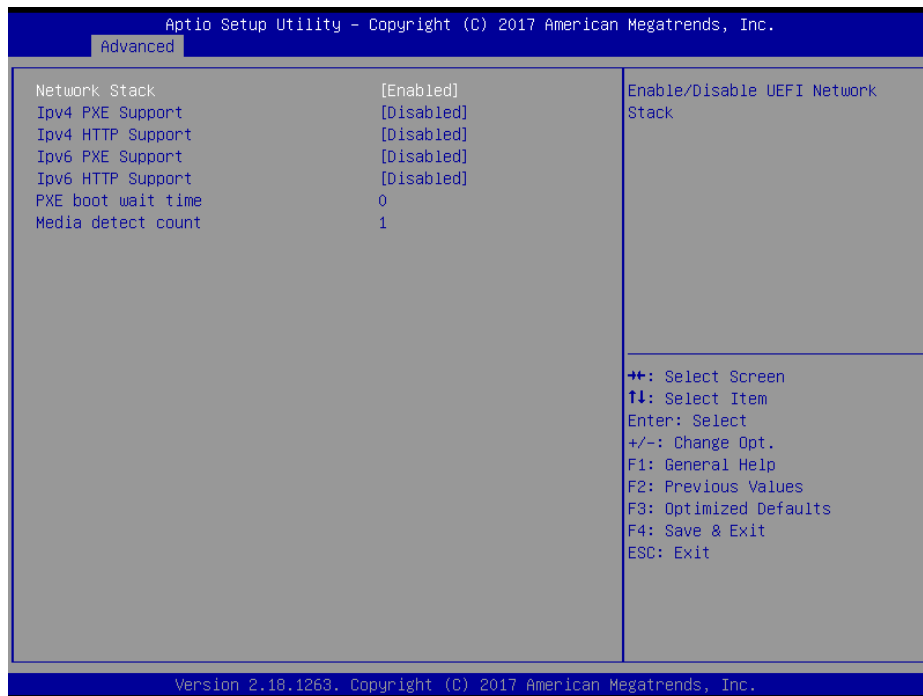

Item	Options	Description
Network Stack	Enabled[Default] Disabled	Enable/Disable UEFI Network Stack.
Ipv4 PXE Support	Enabled Disabled[Default]	Enable Ipv4 PXE Boot Support. If disabled IPV4 PXE boot option will not be created.

ESM-KBLA User's Manual

Ipv4 HTTP Support	Enabled Disabled[Default]	Enable Ipv4 HTTP Boot Support. If disabled IPV4 HTTP boot option will not be created.
Ipv6 PXE Support	Enabled Disabled[Default]	Enable Ipv6 PXE Boot Support. If disabled IPV6 PXE boot option will not be created.
Ipv6 HTTP Support	Enabled Disabled[Default]	Enable Ipv6 HTTP Boot Support. If disabled IPV6 HTTP boot option will not be created.
PXE boot wait time	0	Wait time to press ESC key to abort the PXE boot.
Media detect count	1	Number of times presence of media will be checked.

3.6.2.14 CSM Configuration



Item	Options	Description
CSM Support	Enabled Disabled[Default]	Enable/Disable CSM Support.

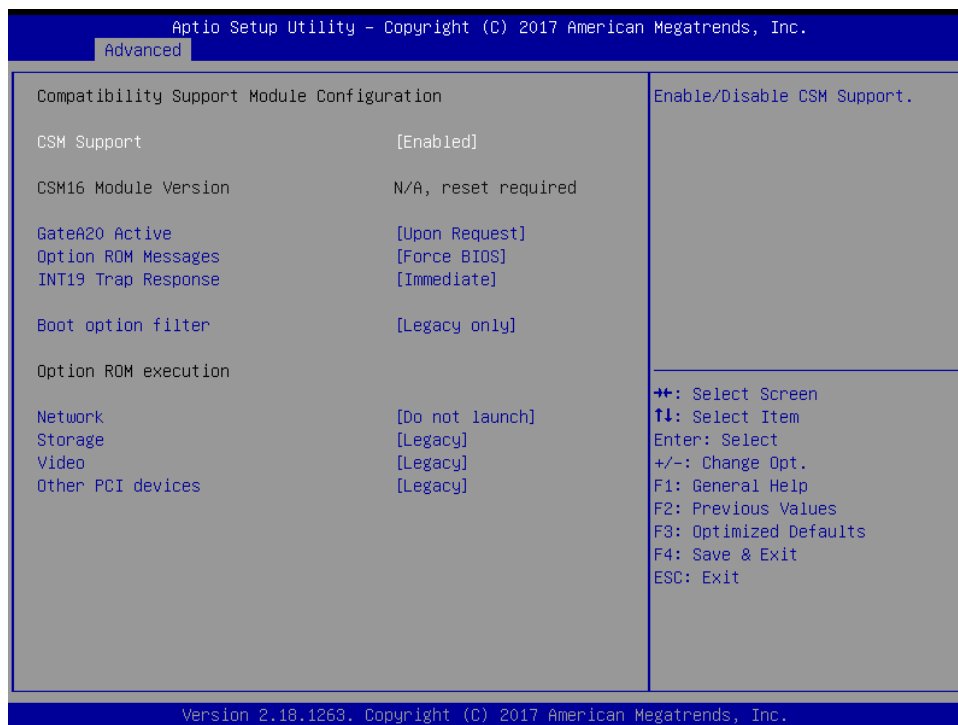

Item	Options	Description
CSM Support	Enabled[Default] Disabled	Enable/Disable CSM Support.
GateA20 Active	Upon Request[Default] Always	UPON REQUEST – GA20 can be disabled using BIOS service. ALWAYS – do not allow disabling GA20; this option is useful when any RT code is executed above 1MB.
Option ROM Messages	Force BIOS[Default] Keep Current	Set display mode for Option ROM.
INT19 Trap Response	Immediate[Default] Postponed	BIOS reaction on INT19 trapping by Option ROM: IMMEDIATE – execute the trap right away; POSTPONED – execute the trap during legacy boot.
Boot Option filter	UEFI and Legacy Legacy only[Default] UEFI only	This option controls Legacy/UEFI ROMs priority.
Network	Do not launch[Default] UEFI Legacy	Controls the execution of UEFI and Legacy PXE OpROM.
Storage	Do not launch UEFI Legacy[Default]	Controls the execution of UEFI and Legacy Storage OpROM.
Video	Do not launch UEFI Legacy[Default]	Controls the execution of UEFI and Legacy Video OpROM.
Other PCI devices	Do not launch UEFI Legacy[Default]	Determines OpROM execution policy for devices other than Network, Storage, or Vide.

ESM-KBLA User's Manual

3.6.2.15 NVMe Configuration

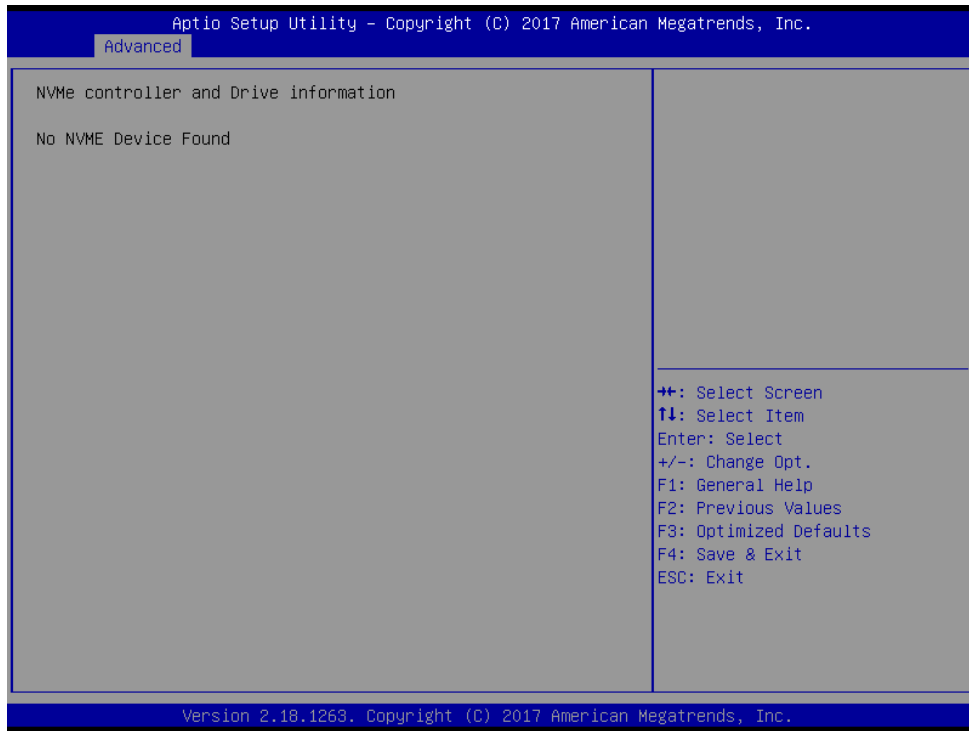

3.6.2.16 USB Configuration

The USB Configuration menu helps read USB information and configures USB settings.

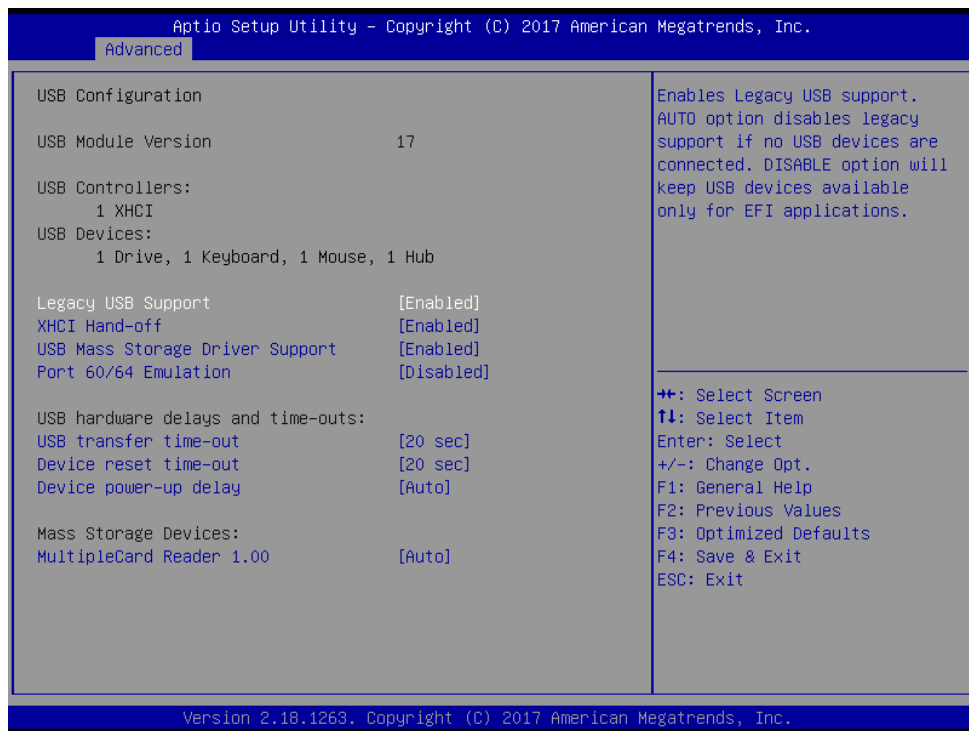

Item	Options	Description
Legacy USB Support	Enabled[Default] Disabled Auto	Enables Legacy USB support. AUTO option disables legacy support if no USB devices are connected. DISABLE option will keep SUB devices available only for EFI applications.
XHCI Hand-off	Enabled[Default] Disabled	This is a workaround for OSes without XHCI hand-off support. The XHCI ownership change should be claimed by XHCI driver.
USB Mass Storage Driver Support	Enabled[Default] Disabled	Enable/Disable USB Mass Storage Driver Support.
Port 60/64 Emulation	Enabled Disabled[Default]	Enable I/O port 60h/64h emulation support. This should be enabled for the complete USB keyboard legacy support for non-USB aware OSes.
USB transfer time-out	1 sec 5 sec 10 sec 20 sec[Default]	The time-out value for Control, Bulk, and Interrupt transfers.
Device reset time-out	10 sec 20 sec[Default] 30 sec 40 sec	USB mass storage device Start Unit command time-out.
Device power-up delay	Auto[Default] Manual	Maximum time the device will take before it properly reports itself to the Host Controller. 'Auto' uses default value: for a Root port it is 100ms, for a Hub port the delay is taken from Hub descriptor.
Mass Storage Devices	Auto[Default] Floppy Forced FDD Hard Disk CD-ROM	Mass storage device emulation type. 'AUTO' enumerates devices according to their media format. Optical drives are emulated as 'CDROM', drives with no media will be emulated according to a drive type.

3.6.3 Chipset

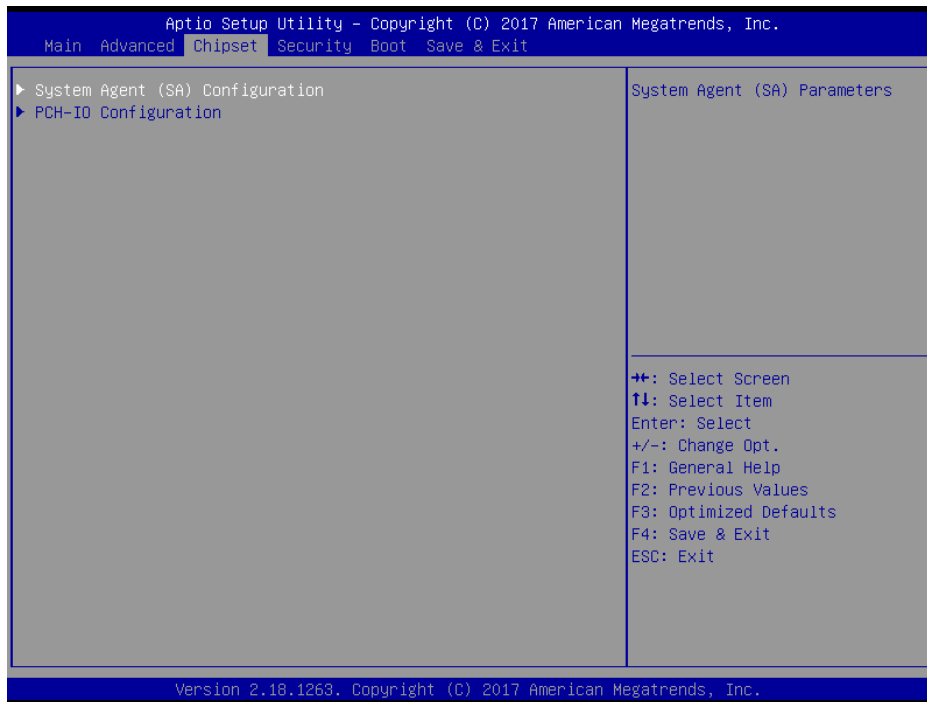

3.6.3.1 System Agent (SA) Configuration



Item	Option	Description
VT-d	Enabled[Default] Disabled	VT-d capability.

3.6.3.1.1 Graphics Configuration

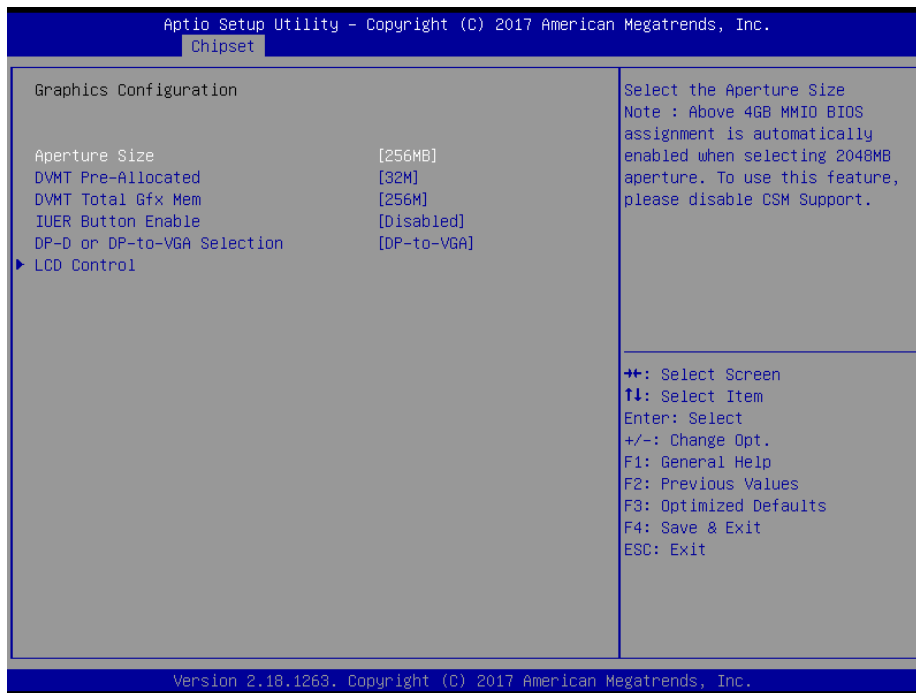

Item	Option	Description
Aperture Size	128MB 256MB 512MB 1024MB 2048MB[Default]	Select the Aperture Size. Note: Above 4GB MMIO BIOS assignment is automatically enabled when selecting 2048MB aperture. To use this feature, please disable CSM Support.
DVMT Pre-Allocated	0M 32M 64M 4M 8M 12M 16M 20M 24M 28M 32M/F7[Default] 36M 40M 44M 48M 52M 56M 60M	Select DVMT 5.0 Pre-Allocated (Fixed) Graphics Memory size used by the Internal Graphics Device.
DVMT Total Gfx Mem	256M[Default] 128M MAX	Select DVMT 5.0 Total Graphics Memory size used by the Internal Graphics Device.

ESM-KBLA User's Manual

IUER Button Enable	Disabled[Default] Enabled	Enable/Disable IUER Button Functionality.
DP-D or DP-to-VGA Selection	DP-D DP-to-VGA[Default]	Selection of DP Port-D output.

3.6.3.1.1.1 LCD Control

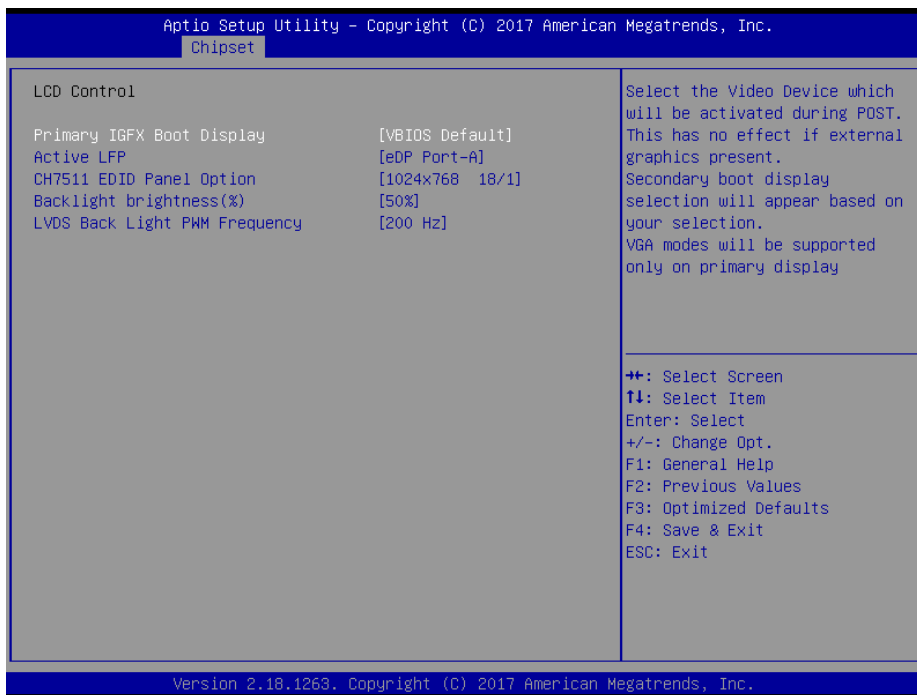

Item	Option	Description
Primary IGFX Boot Display	VBIOS Default[Default], EFP LFP EFP3 EFP2 EFP4	Select the Video Device which will be activated during POST. This has no effect if external graphics present. Secondary boot display selection will appear based on your selection. VGA modes will be supported only on primary display.
Active LFP	No eDP eDP Port-A[Default],	Select the Active LFP Configuration. No LVDS:VBIOS does not enable LVDS. Int-LVDS:VBIOS enable LVDS driver by Integrated encoder. SDVO LVDS:VBIOS enables LVDS driver by SDVO encoder. eDP Port-A:LFP Driven by Int-DisplayPort encoder from Port-A. eDP Port-D:LFP Driven by Int-DisplayPort encoder from Port-D(through PCH).
CH7511 EDID Panel Option	1024x768 18/1[Default] 1366x768 18/1 1024x600 18/1 1280x800 18/1 1920x1200 24/2 640x480 18/1	Port1-EDP to LVDS (Chrotel 7511) Panel EDID Option.

	800x480 18/1 1920x1080 18/2 1280x1024 24/2 1440x900 18/2 1600x1200 24/2 1366x768 24/1 1920x1080 24/2 1680x1050 24/2	
Backlight brightness (%)	00% 25% 50% [Default] 75% 100%	Select LVDS back light PWM duty.
LVDS Back Light PWM Frequency	200 Hz [Default] 300 Hz 400 Hz 500 Hz 700 Hz 1kHz 2kHz 3kHz 5kHz 10kHz 20kHz	Select LVDS back light PWM Frequency.



Item	Option	Description
Primary IGFX Boot Display	VBIOS Default [Default] , EFP LFP	Select the Video Device which will be activated during POST. This has no effect if external graphics present. Secondary boot

ESM-KBLA User's Manual

	EFP3 EFP2 EFP4	display selection will appear based on your selection. VGA modes will be supported only on primary display.
Active LFP	No eDP[Default], eDP Port-A	Select the Active LFP Configuration. No LVDS:VBIOS does not enable LVDS. Int-LVDS:VBIOS enable LVDS driver by Integrated encoder. SDVO LVDS:VBIOS enables LVDS driver by SDVO encoder. eDP Port-A:LFP Driven by Int-DisplayPort encoder from Port-A. eDP Port-D:LFP Driven by Int-DisplayPort encoder from Port-D(through PCH).

3.6.3.1.2 PEG Port Configuration

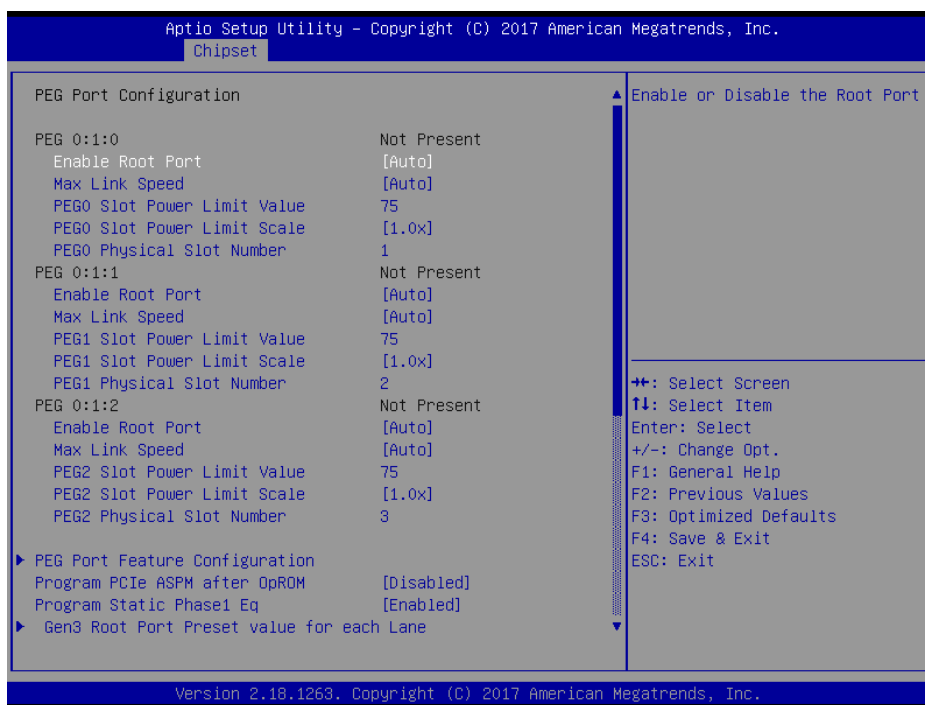

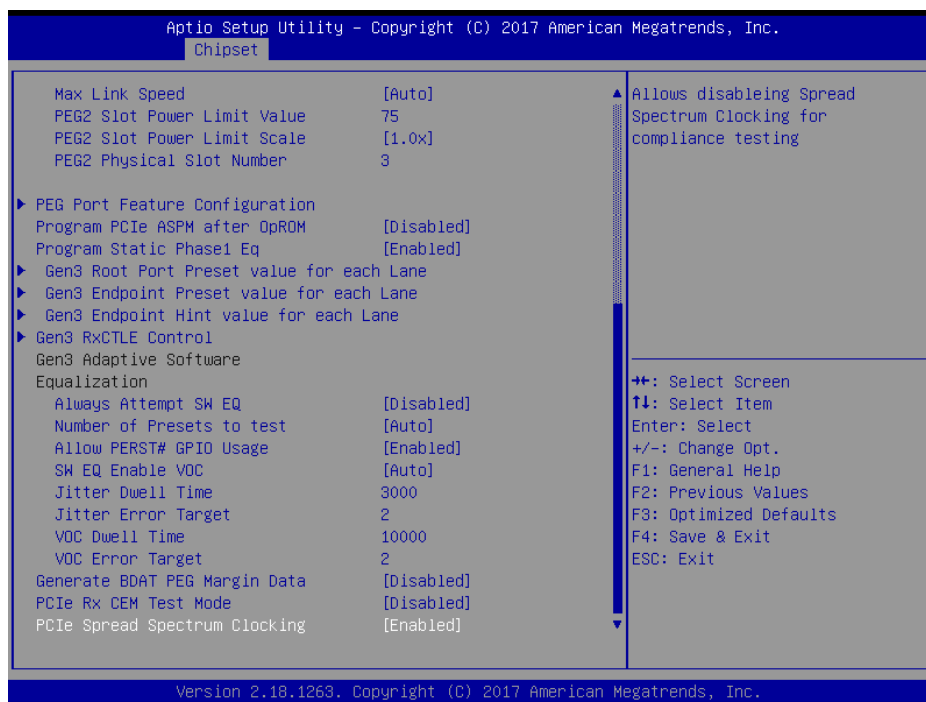

PEG 0:1:0

Item	Option	Description
Enable Root Port	Disabled Enabled Auto[Default]	Enable or Disable the Root Port.
Max Link Speed	Auto[Default] Gen1 Gen2 Gen3	Configure PEG 0:1:0 Max Speed.
PEG0 Slot Power Limit Value	0-255 75[Default]	Sets the upper limit on power supplied by slot, Power limit (in Watts) is calculated by multiplying this value by the Slot Power Limit Scale. Values 0-255.
PEG0 Slot Power Limit Scale	1.0x[Default] 0.1x 0.01x 0.001x	Select the scale used for the Slot Power Limit Value.
PEG0 Physical Slot Number	0-8191 1[Default]	Set the physical slot number attached to this Port. The number has to be globally unique within the chassis. Values 0-8191.

PEG 0:1:1

Item	Option	Description
Enable Root Port	Disabled Enabled Auto[Default]	Enable or Disable the Root Port.
Max Link Speed	Auto[Default] Gen1 Gen2	Configure PEG 0:1:1 Max Speed.

ESM-KBLA User's Manual

	Gen3	
PEG1 Slot Power Limit Value	0-255 75[Default]	Sets the upper limit on power supplied by slot, Power limit (in Watts) is calculated by multiplying this value by the Slot Power Limit Scale. Values 0-255.
PEG1 Slot Power Limit Scale	1.0x[Default] 0.1x 0.01x 0.001x	Select the scale used for the Slot Power Limit Value.
PEG1 Physical Slot Number	0-8191 2[Default]	Set the physical slot number attached to this Port. The number has to be globally unique within the chassis. Values 0-8191.

PEG 0:1:2

Item	Option	Description
Enable Root Port	Disabled Enabled Auto[Default]	Enable or Disable the Root Port.
Max Link Speed	Auto[Default] Gen1 Gen2 Gen3	Configure PEG 0:1:2 Max Speed.
PEG2 Slot Power Limit Value	0-255 75[Default]	Sets the upper limit on power supplied by slot, Power limit (in Watts) is calculated by multiplying this value by the Slot Power Limit Scale. Values 0-255.
PEG2 Slot Power Limit Scale	1.0x[Default] 0.1x 0.01x 0.001x	Select the scale used for the Slot Power Limit Value.
PEG2 Physical Slot Number	0-8191 3[Default]	Set the physical slot number attached to this Port. The number has to be globally unique within the chassis. Values 0-8191.
Program PCIe ASPM after OpROM	Disabled[Default] Enabled	Enabled: PCIe ASPM will be programmed after OpROM. Disabled: PCIe ASPM will be programmed before OpROM.
Program Static Phase1 Eq	Disabled Enabled[Default]	Program Phase1 Presets/CTLEp.

3.6.3.1.3.1 PEG Port Feature Configuration

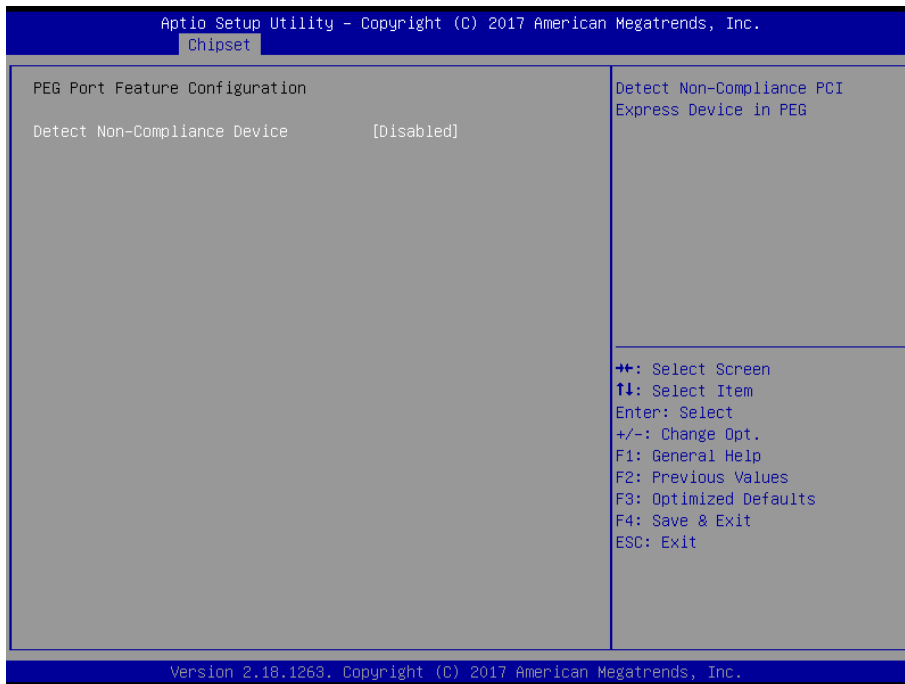

Item	Option	Description
Detect Non-Compliance Device	Disabled[Default], Enabled	Detect Non-Compliance PCI Express Device in PEG.

3.6.3.1.3.2 Gen3 Root Port Preset value for each Lane

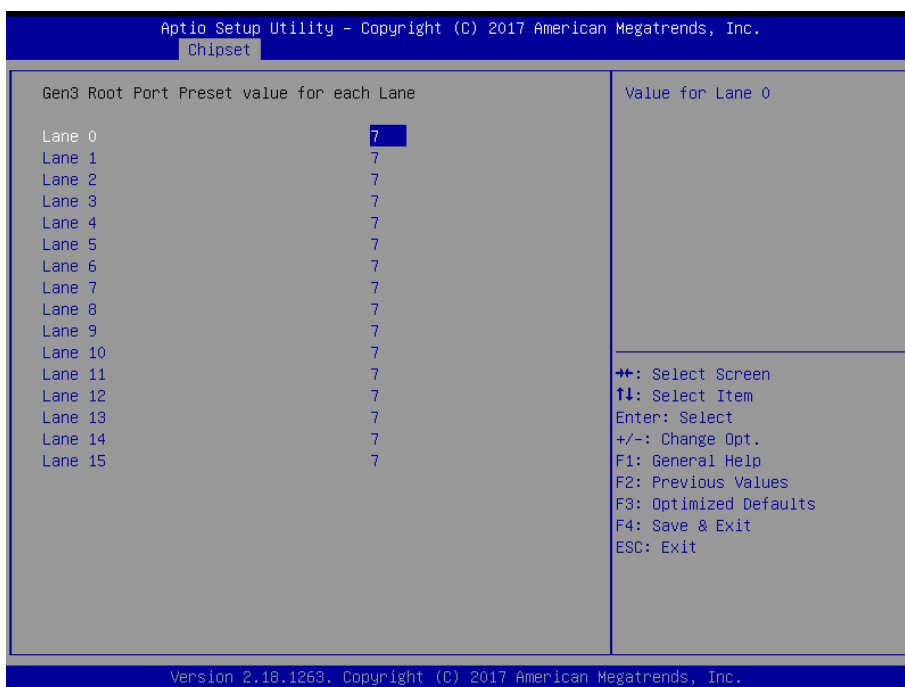

ESM-KBLA User's Manual

Item	Option	Description
Lane0/1/2/3/4/5/6/7 /8/9/10/11/12/13/14/15	0-7	Value of Lane 0/1/2/3/4/5/6/7/8/9/10/11/12/13/14/15.

3.6.3.1.3.3 Gen3 Endpoint Preset value for each Lane

Aptio Setup Utility - Copyright (C) 2017 American Megatrends, Inc.
Chipset

Gen3 Endpoint Preset value for each Lane		Value for Lane 0
Lane 0	7	
Lane 1	7	
Lane 2	7	
Lane 3	7	
Lane 4	7	
Lane 5	7	
Lane 6	7	
Lane 7	7	
Lane 8	7	
Lane 9	7	
Lane 10	7	
Lane 11	7	
Lane 12	7	
Lane 13	7	
Lane 14	7	
Lane 15	7	

++: Select Screen
 ↑↓: Select Item
 Enter: Select
 +/-: Change Opt.
 F1: General Help
 F2: Previous Values
 F3: Optimized Defaults
 F4: Save & Exit
 ESC: Exit

Version 2.18.1263. Copyright (C) 2017 American Megatrends, Inc.

Item	Option	Description
Lane0/1/2/3/4/5/6/7 /8/9/10/11/12/13/14/15	0-7	Value of Lane 0/1/2/3/4/5/6/7/8/9/10/11/12/13/14/15.

3.6.3.1.3.4 Gen3 Endpoint Hint value for each Lane

Aptio Setup Utility - Copyright (C) 2017 American Megatrends, Inc.
Chipset

Gen3 Endpoint Hint value for each Lane		Value for Lane 0
Lane 0	2	
Lane 1	2	
Lane 2	2	
Lane 3	2	
Lane 4	2	
Lane 5	2	
Lane 6	2	
Lane 7	2	
Lane 8	2	
Lane 9	2	
Lane 10	2	
Lane 11	2	
Lane 12	2	
Lane 13	2	
Lane 14	2	
Lane 15	2	

++: Select Screen
 ↑↓: Select Item
 Enter: Select
 +/-: Change Opt.
 F1: General Help
 F2: Previous Values
 F3: Optimized Defaults
 F4: Save & Exit
 ESC: Exit

Version 2.18.1263. Copyright (C) 2017 American Megatrends, Inc.

Item	Option	Description
Lane0/1/2/3/4/5/6/7 /8/9/10/11/12/13/14/15	0-2	Value of Lane 0/1/2/3/4/5/6/7/8/9/10/11/12/13/14/15.

3.6.3.1.3.5 Gen3 RxCTLE Control

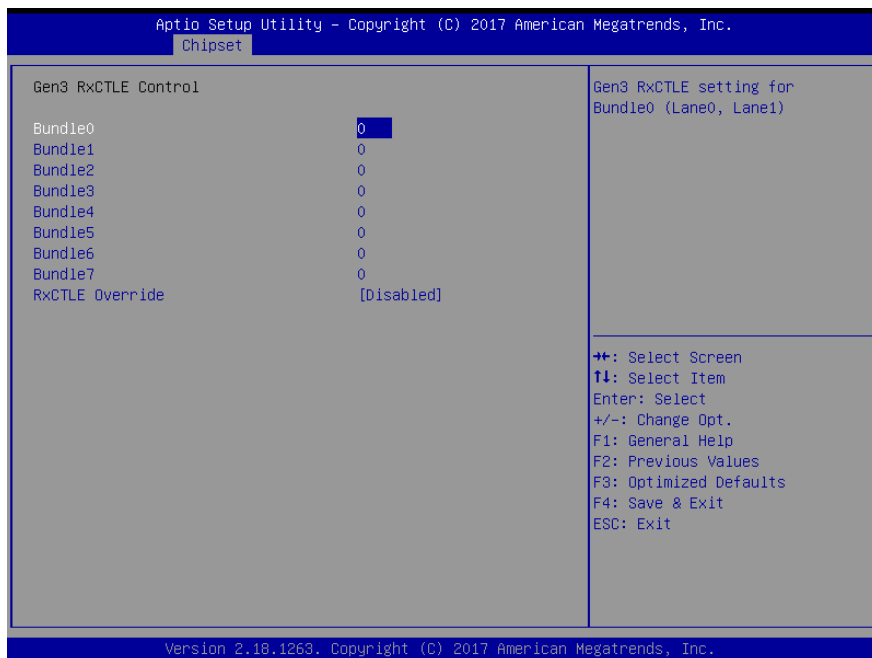

Item	Option	Description
Bundle0	0	Gen3 RxCTLE setting for Bundle0 (Lane0, Lane1).
Bundle1	0	Gen3 RxCTLE setting for Bundle1 (Lane2, Lane3).
Bundle2	0	Gen3 RxCTLE setting for Bundle2 (Lane4, Lane5).
Bundle3	0	Gen3 RxCTLE setting for Bundle3 (Lane6, Lane7).
Bundle4	0	Gen3 RxCTLE setting for Bundle4 (Lane8, Lane9).
Bundle5	0	Gen3 RxCTLE setting for Bundle5 (Lane10, Lane11).
Bundle6	0	Gen3 RxCTLE setting for Bundle6 (Lane12, Lane13).
Bundle7	0	Gen3 RxCTLE setting for Bundle7 (Lane14, Lane15).
RxCTLE Override	Disabled[Default], Enabled	When Enabled, it overrides PEG's RxCTLE adaptive behaviour.

3.6.3.2 PCH-IO Configuration

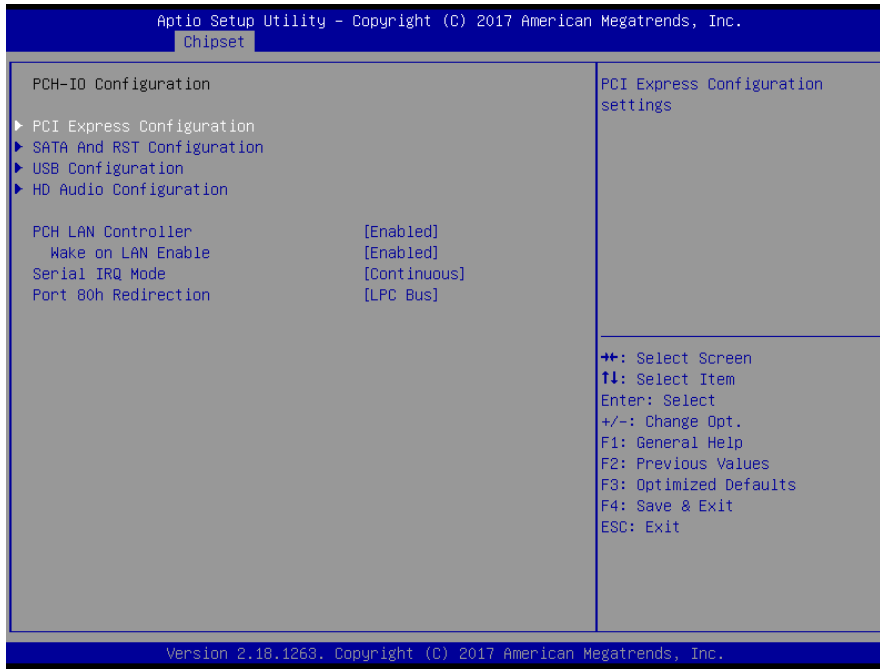

Item	Option	Description
PCH LAN Controller	Disabled Enabled [Default]	Enable or disable onboard NIC.
Wake on LAN Enable	Disabled Enabled [Default]	Enable or disable integrated LAN to wake the system.
Serial IRQ Mode	Quiet Continuous [Default]	Configure Serial IRQ Mode.
Port 80h Redirection	LPC Bus [Default] PCIE Bus	Control where the Port 80h cycles are sent.

3.6.3.2.1 PCI Express Configuration

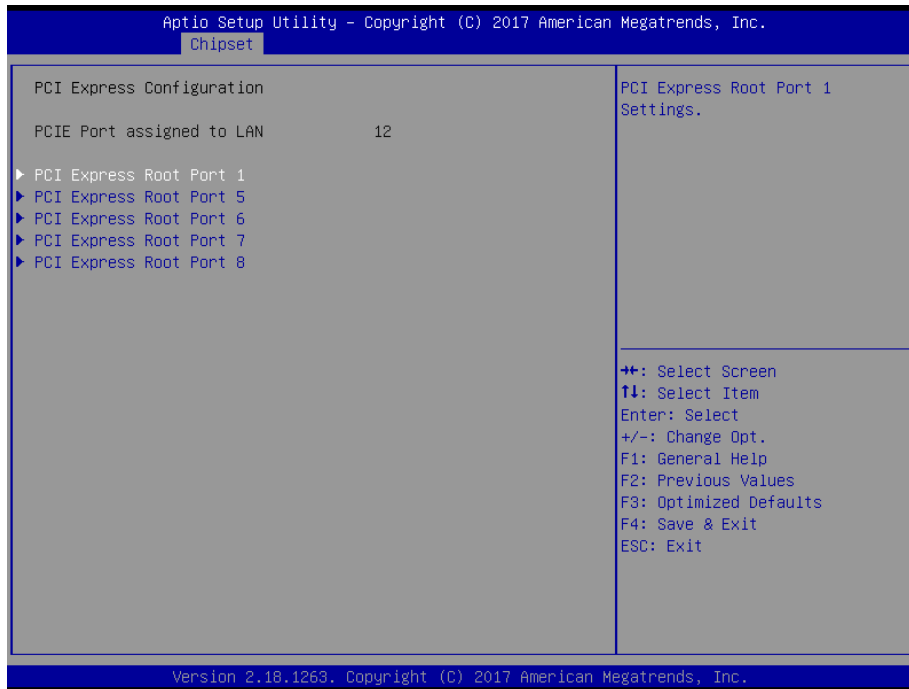

3.6.3.2.1.1 PCI Express Root Port1

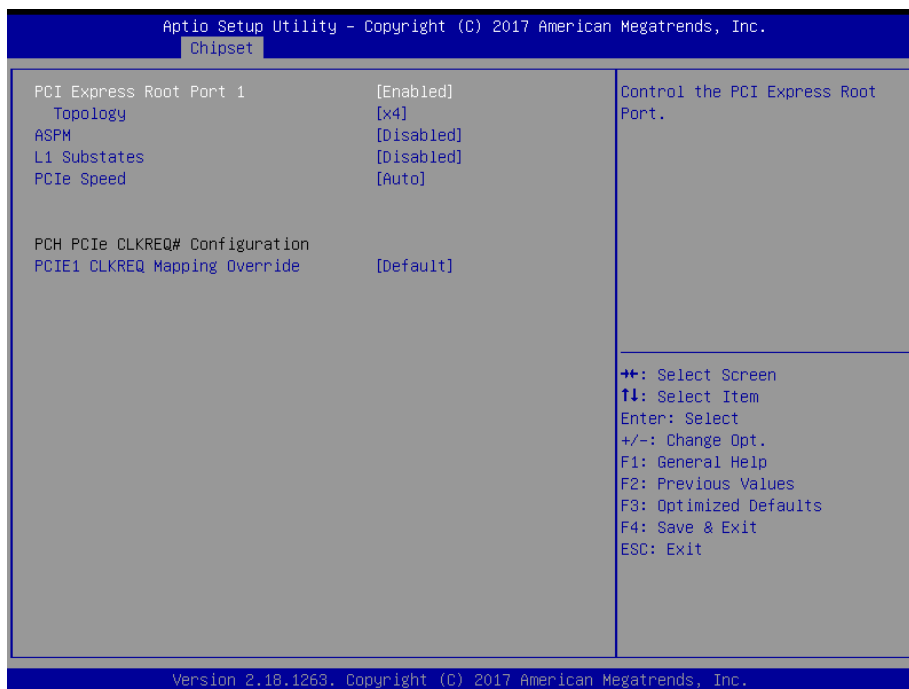

Item	Option	Description
PCI Express Root Port 1	Enabled[Default], Disabled	Control the PCI Express Root Port.
Topology	Unknown x1, x4[Default] Sata Express M2	Identify the SATA Topology if it is Default or ISATA or Flex or DirectConnect or M2.

ESM-KBLA User's Manual

ASPM	Auto L0sL1 L1 L0s Disabled[Default],	Set the ASPM Level: Force L0s – Force all links to L0s State AUTO – BIOS auto configure DISABLE – Disables ASPM.
L1 Substates	Disabled[Default], L1.1 L1.2 L1.1 & L1.2	PCI Express L1 Substates settings.
PCIe Speed	Auto[Default] Gen1 Gen2 Gen3	Configure PCIe Speed.
PCIE1 CLKREQ Mapping Override	Default[Default] No CLKREQ Custom number	PCIE CLKREQ Qverride for default platform mapping.

3.6.3.2.1.2 PCI Express Root Port5

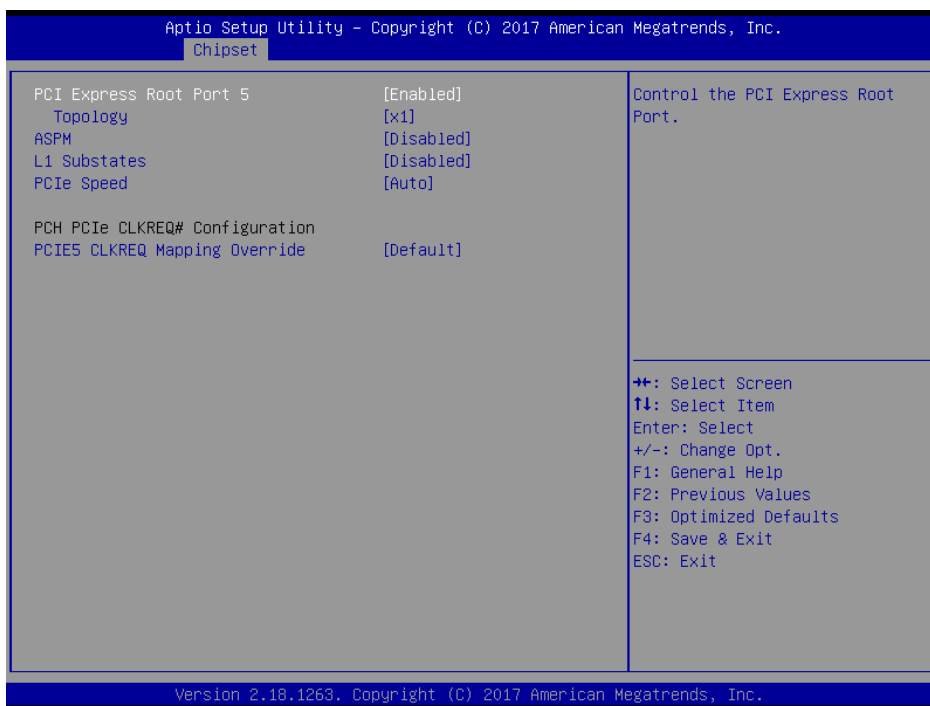

Item	Option	Description
PCI Express Root Port 5	Enabled[Default], Disabled	Control the PCI Express Root Port.
Topology	Unknown x1[Default], x4 Sata Express M2	Identify the SATA Topology if it is Default or ISATA or Flex or DirectConnect or M2.
ASPM	Auto, L0sL1	Set the ASPM Level: Force L0s – Force all links to L0s State AUTO – BIOS auto

	L1 L0s Disabled[Default]	configure DISABLE – Disables ASPM.
L1 Substates	Disabled[Default], L1.1 L1.2 L1.1 & L1.2	PCI Express L1 Substates settings.
PCIe Speed	Auto[Default] Gen1 Gen2 Gen3	Configure PCIe Speed.
PCIE5 CLKREQ Mapping Override	Default[Default] No CLKREQ Custom number	PCIE CLKREQ Qverride for default platform mapping.

3.6.3.2.1.3 PCI Express Root Port6

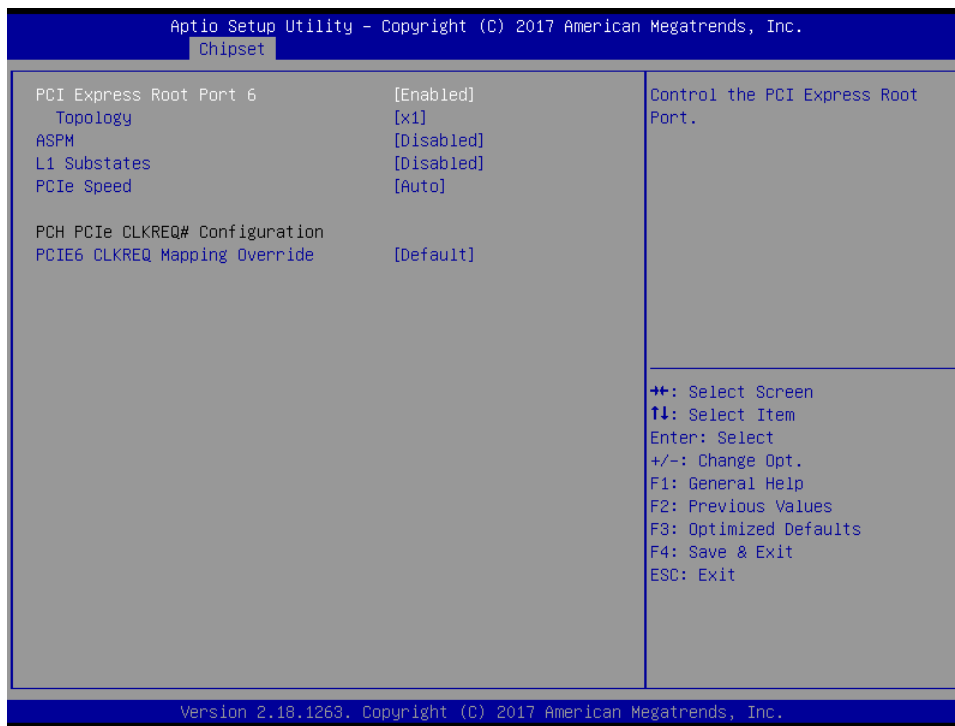

Item	Option	Description
PCI Express Root Port 6	Enabled[Default], Disabled	Control the PCI Express Root Port.
Topology	Unknown x1[Default], x4 Sata Express M2	Identify the SATA Topology if it is Default or ISATA or Flex or DirectConnect or M2.
ASPM	Auto, L0sL1 L1 L0s Disabled[Default]	Set the ASPM Level: Force L0s – Force all links to L0s State AUTO – BIOS auto configure DISABLE – Disables ASPM.

ESM-KBLA User's Manual

L1 Substates	Disabled[Default], L1.1 L1.2 L1.1 & L1.2	PCI Express L1 Substates settings.
PCIe Speed	Auto[Default] Gen1 Gen2 Gen3	Configure PCIe Speed.
PCIE6 CLKREQ Mapping Override	Default[Default] No CLKREQ Custom number	PCIE CLKREQ Qverride for default platform mapping.

3.6.3.2.1.4 PCI Express Root Port7

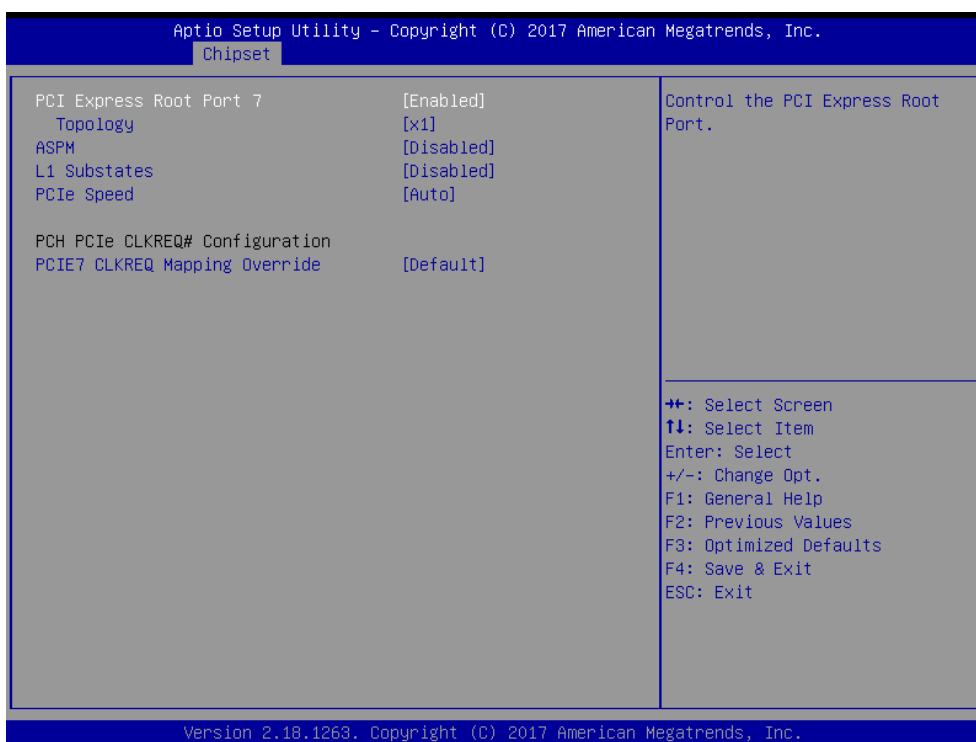

Item	Option	Description
PCI Express Root Port 7	Enabled[Default], Disabled	Control the PCI Express Root Port.
Topology	Unknown x1[Default], x4 Sata Express M2	Identify the SATA Topology if it is Default or ISATA or Flex or DirectConnect or M2.
ASPM	Auto, L0sL1 L1 L0s Disabled[Default]	Set the ASPM Level: Force L0s – Force all links to L0s State AUTO – BIOS auto configure DISABLE – Disables ASPM.

L1 Substates	Disabled[Default], L1.1 L1.2 L1.1 & L1.2	PCI Express L1 Substates settings.
PCIe Speed	Auto[Default] Gen1 Gen2 Gen3	Configure PCIe Speed.
PCIe7 CLKREQ Mapping Override	Default[Default] No CLKREQ Custom number	PCIe CLKREQ Qverride for default platform mapping.

3.6.3.2.1.5 PCI Express Root Port8

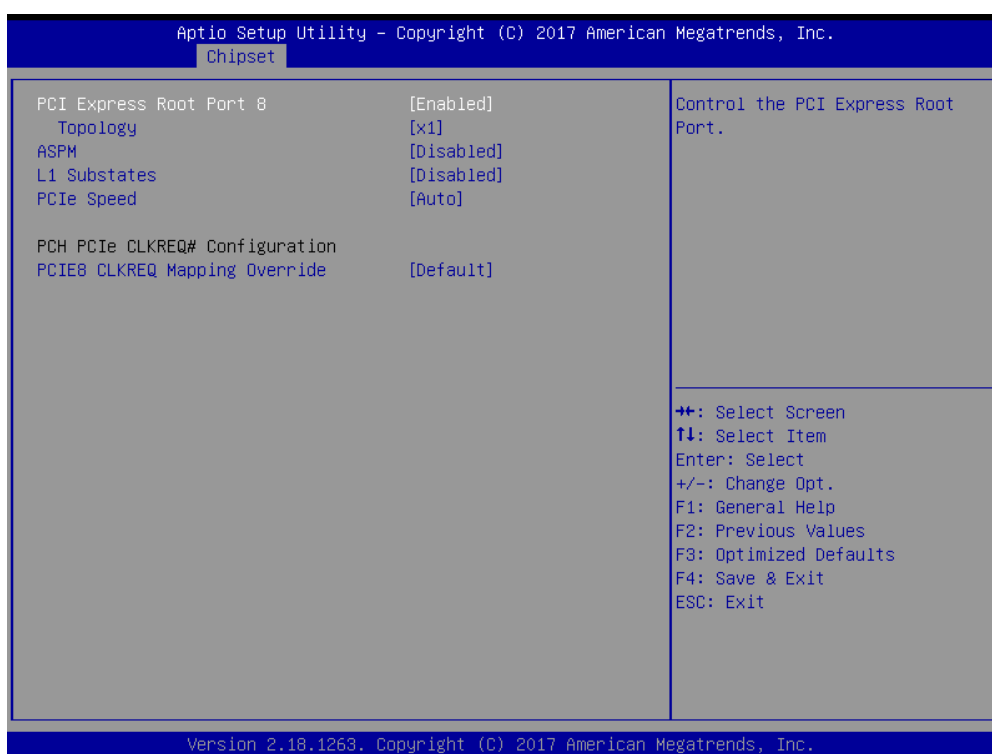

Item	Option	Description
PCI Express Root Port 8	Enabled[Default], Disabled	Control the PCI Express Root Port.
Topology	Unknown x1[Default], x4 Sata Express M2	Identify the SATA Topology if it is Default or ISATA or Flex or DirectConnect or M2.
ASPM	Auto, L0sL1 L1 L0s Disabled[Default]	Set the ASPM Level: Force L0s – Force all links to L0s State AUTO – BIOS auto configure DISABLE – Disables ASPM.
L1 Substates	Disabled[Default], L1.1	PCI Express L1 Substates settings.

ESM-KBLA User's Manual

	L1.2 L1.1 & L1.2	
PCIe Speed	Auto[Default] Gen1 Gen2 Gen3	Configure PCIe Speed.
PCIE8 CLKREQ Mapping Override	Default[Default] No CLKREQ Custom number	PCIE CLKREQ Qverride for default platform mapping.

3.6.3.2.2 SATA And RST Configuration

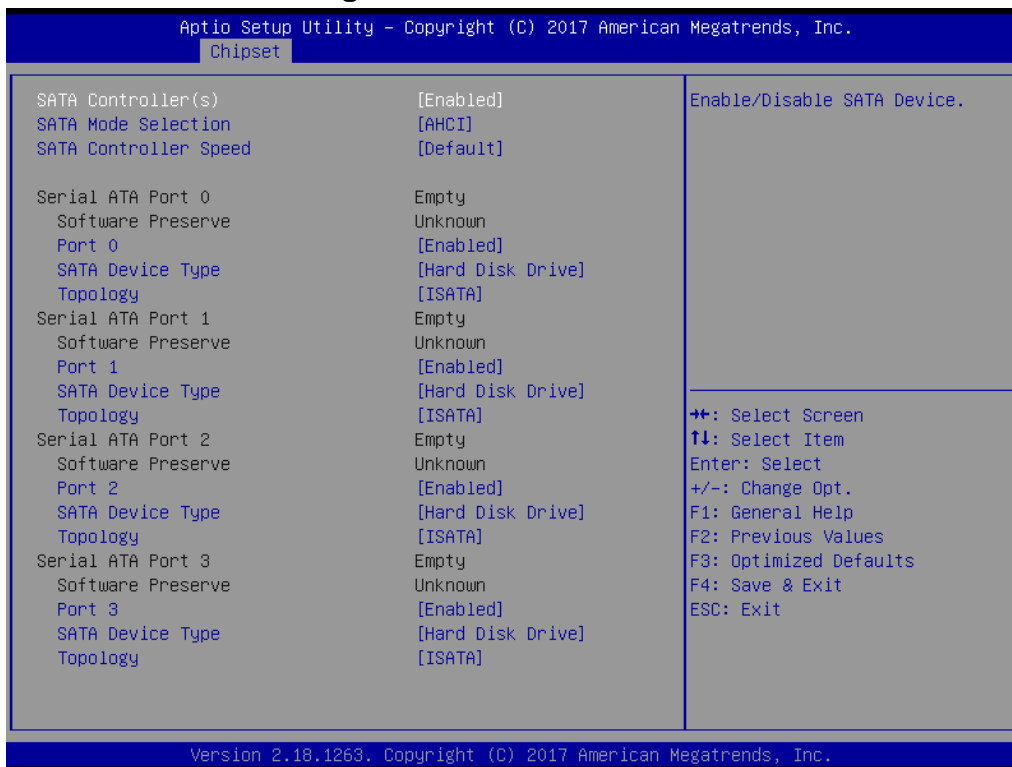

Item	Options	Description
SATA Controller(s)	Enabled[Default] Disabled,	Enable/Disable SATA Device.
SATA Mode Selection	AHCI[Default], RAID	Determines how SATA controller(s) operate.
SATA Controller Speed	Default[Default] Gen1 Gen2 Gen3	Indicates the maximum speed the SATA controller can support.
Port 0/1/2/3	Enabled[Default] Disabled	Enable or Disable SATA Port.
SATA Device Type	Hard Disk Drive[Default] Solid State Drive	Identify the SATA port is connected to Solid State Drive or Hard Disk Drive.

<p>Technology</p>	<p>Unknown ISATA[Default] Direct Connect Flex M2</p>	<p>Identify the SATA Topology if it is Default or ISATA or Flex or DirectConnect or M2.</p>
--------------------------	--	---

3.6.3.2.3 USB Configuration

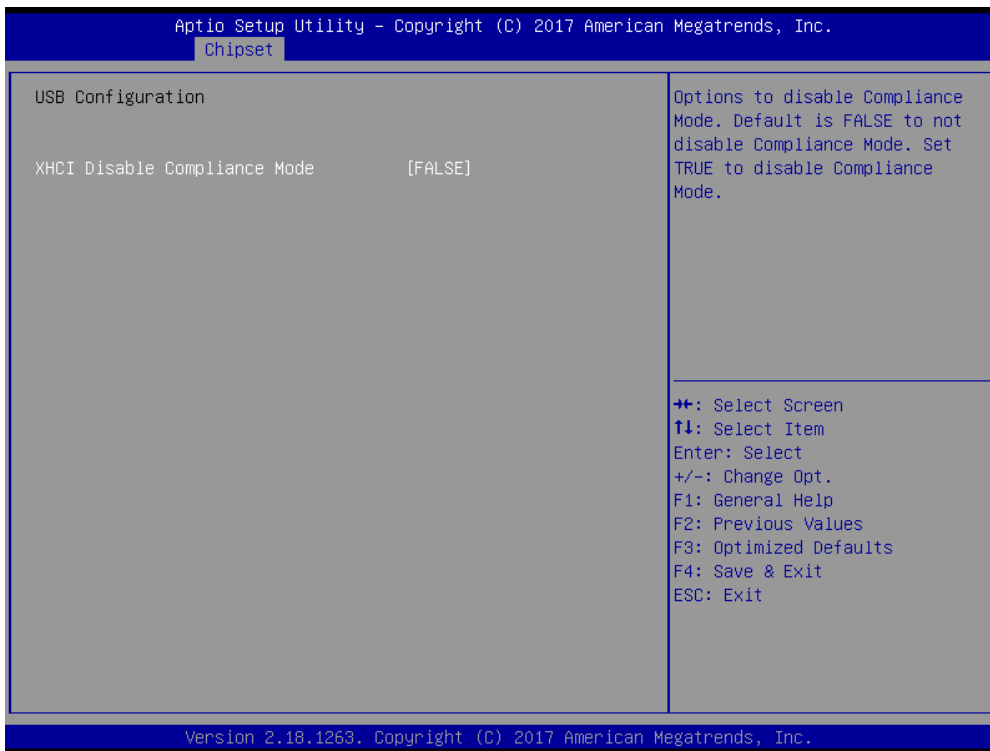

Item	Option	Description
<p>XHCI Disable Compliance Mode</p>	<p>FALSE[Default], TRUE</p>	<p>Option to disable Compliance Mode. Default is FALSE to not disable Compliance Mode. Set TRUE to disable Compliance Mode.</p>

3.6.3.2.4 HD Audio Configuration

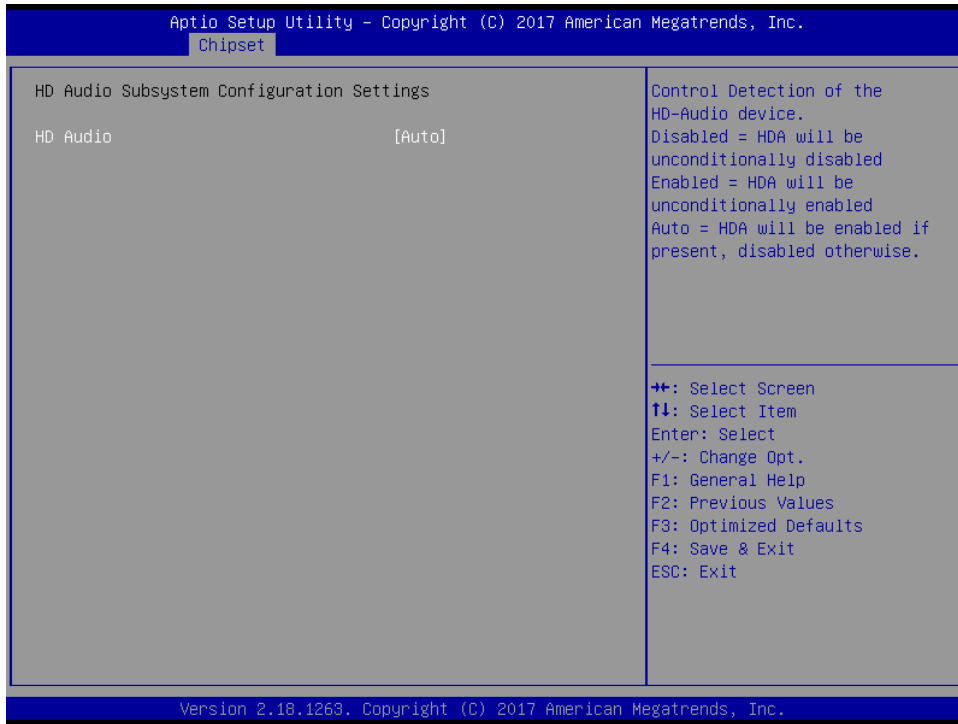

Item	Option	Description
HD Audio	Disabled Enabled Auto [Default] ,	Control Detection of the HD-Audio device. Disable = HDA will be unconditionally disabled Enabled = HDA will be unconditionally enabled Auto = HDA will be enabled if present, disabled otherwise.

3.6.4 Security

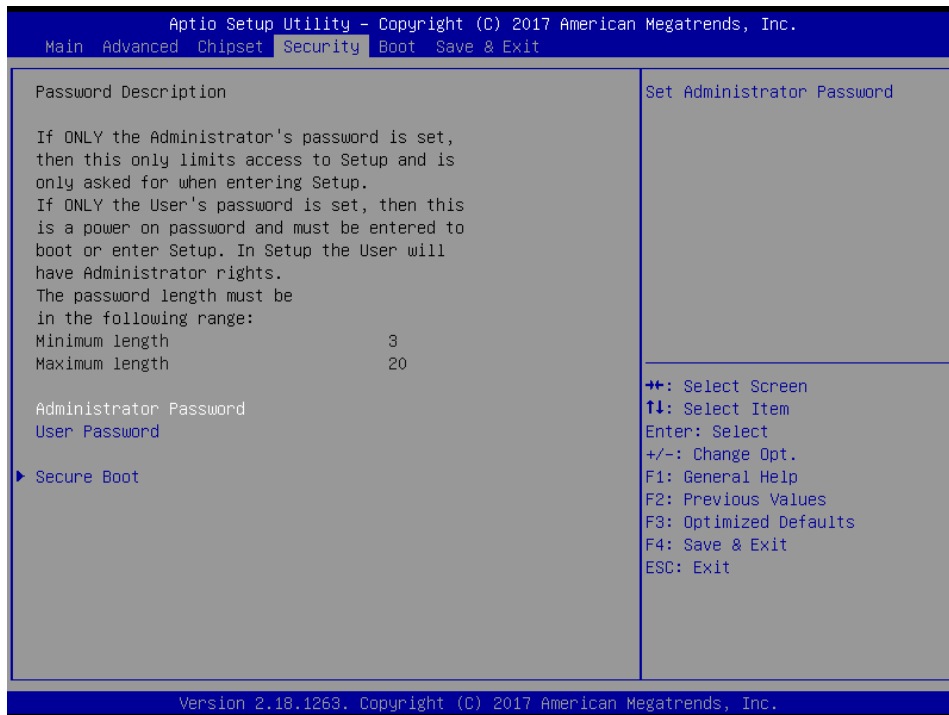

- **Administrator Password**

Set setup Administrator Password

- **User Password**

Set User Password

3.6.4.1 Secure Boot

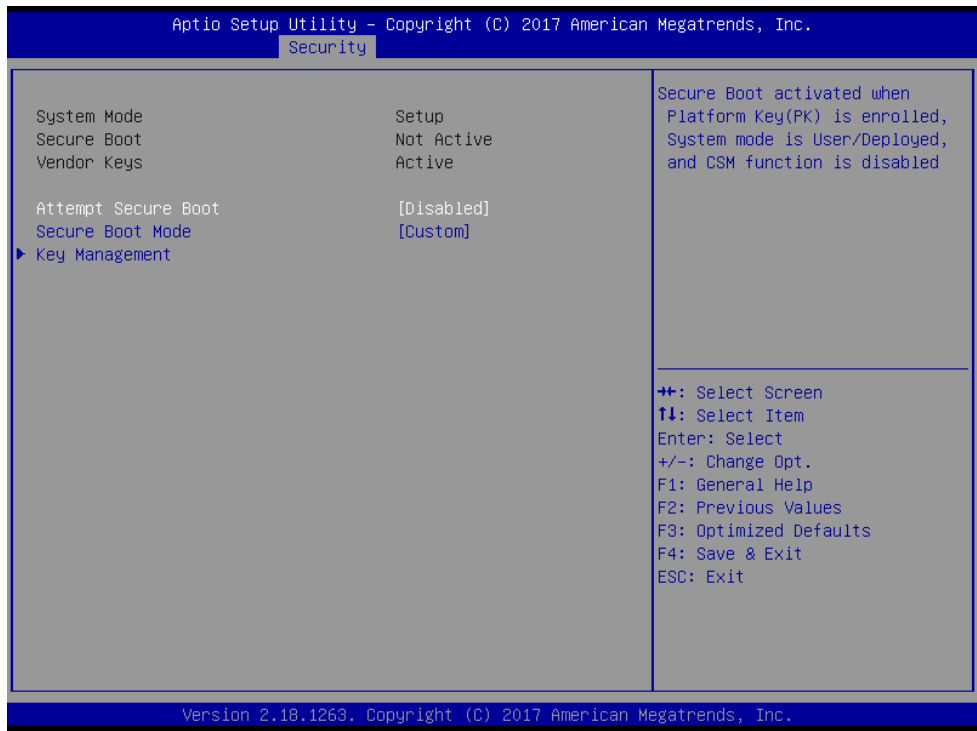

Item	Option	Description
Attempt Secure Boot	Disabled[Default] Enabled	Secure Boot can be enabled if 1.System running in User mode with enrolled Platform Key(PK) 2.CSM function is disabled.
Secure Boot Mode	Standard Custom[Default]	Secure Boot mode selector: Standard/Custom. In Custom mode Secure Boot Variables can be configured without authentication.

3.6.4.1.1 Key Management

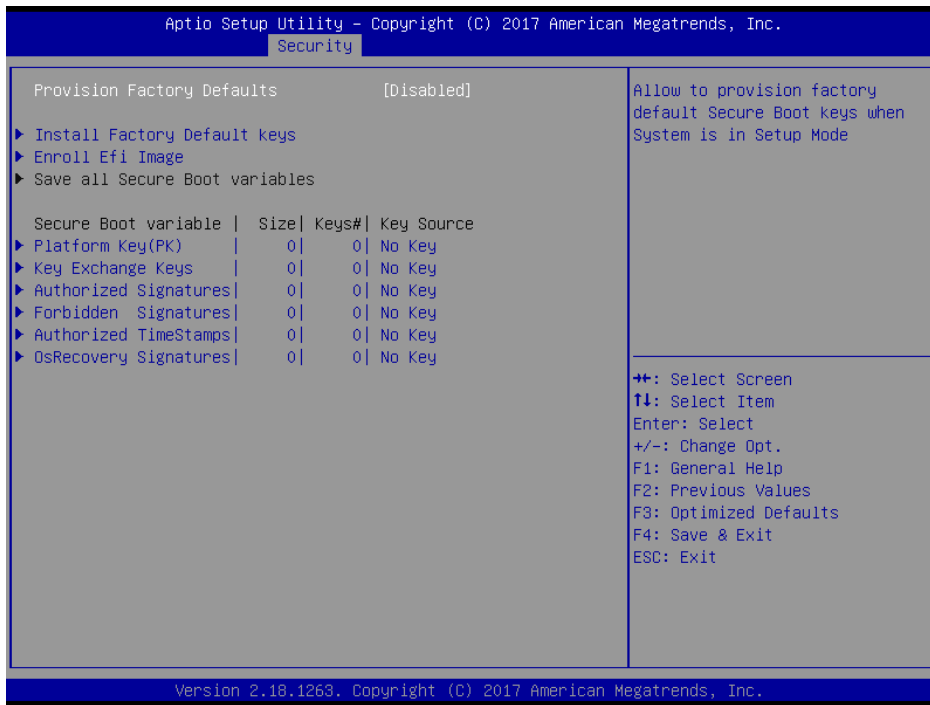

Item	Option	Description
Provision Factory Defaults	Disabled[Default] Enabled	Allow to provision factory default Secure Boot keys when System is in Setup Mode.

3.6.5 Boot

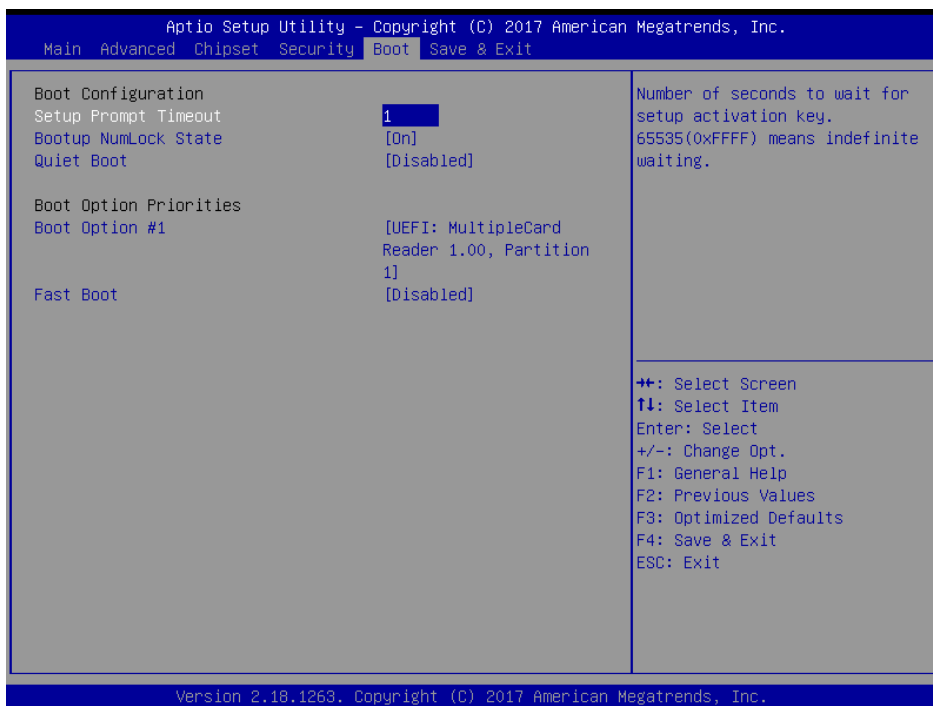

ESM-KBLA User’s Manual

Item	Option	Description
Setup Prompt Timeout	1~ 65535	Number of seconds to wait for setup activation key. 65535(0xFFFF) means indefinite waiting.
Bootup NumLock State	On[Default] Off	Select the Keyboard NumLock state
Quiet Boot	Disabled[Default] Enabled	Enables or disables Quiet Boot option
Fast Boot	Disabled[Default] Enabled	Enables or disables boot with initialization of a minimal set of devices required to launch active boot option. Has no effect for BBS boot options.
Boot Option #1	Set the system boot order.	

3.6.6 Save and exit

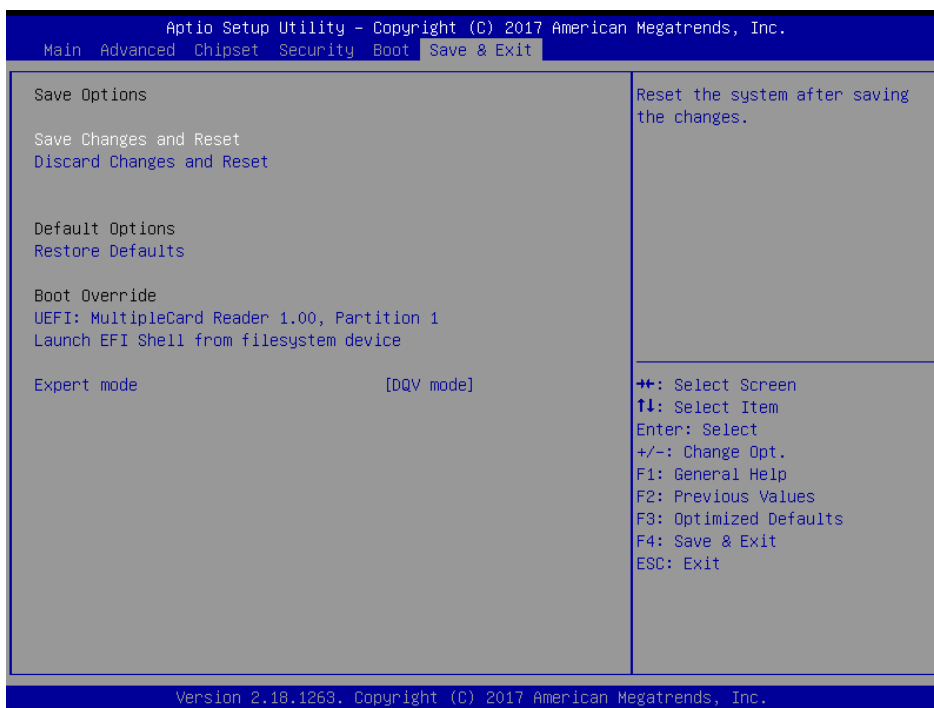

3.6.6.1 Save Changes and Reset

Reset the system after saving the changes.

3.6.6.2 Discard Changes and Reset

Any changes made to BIOS settings during this session of the BIOS setup program are discarded. The setup program then exits and reboots the controller.

3.6.6.3 *Restore Defaults*

This option restores all BIOS settings to the factory default. This option is useful if the controller exhibits unpredictable behavior due to an incorrect or inappropriate BIOS setting.

3.6.6.4 *Launch EFI Shell from filesystem device*

Attempts to Launch EFI Shell application (Shellx64.efi) from one of the available filesystem devices.

4. Drivers Installation



Note: Installation procedures and screen shots in this section are for your reference and may not be exactly the same as shown on your screen.

4.1 Install Chipset Driver

Insert the Supporting DVD-ROM to DVD-ROM drive, and it should show the index page of our products automatically. If not, locate Index.htm and choose the product from the menu left, or link to [/Driver_Chipset/Intel/ESM-KBLH_KBLA](#).



Note: The installation procedures and screen shots in this section are based on Windows 10 operation system. If the warning message appears while the installation process, click Continue to go on.



Step 3. Click Install.



Step1. Click Next.



Step 4. Complete setup.



Step 2. Click Accept.

4.2 Install Display Driver

Insert the Supporting DVD-ROM to DVD-ROM drive, and it should show the index page of our products automatically. If not, locate Index.htm and choose the product from the menu left, or link to / **VGA/ESM-KBLH_KBLA**.



Note: The installation procedures and screen shots in this section are based on Windows 10 operation system.

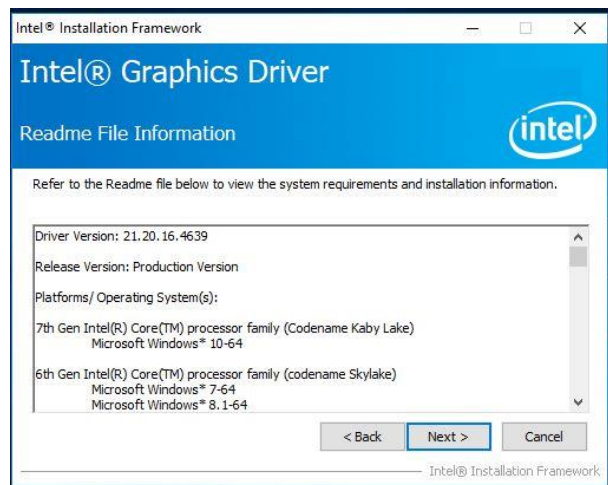

Step 3. Click Next.

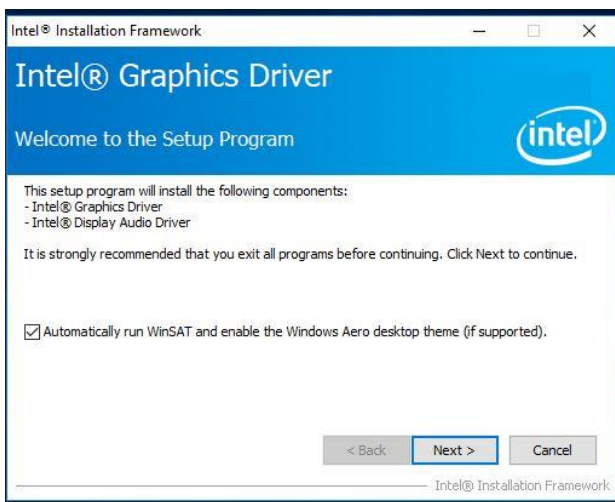

Step 1. Click Next to continue installation.

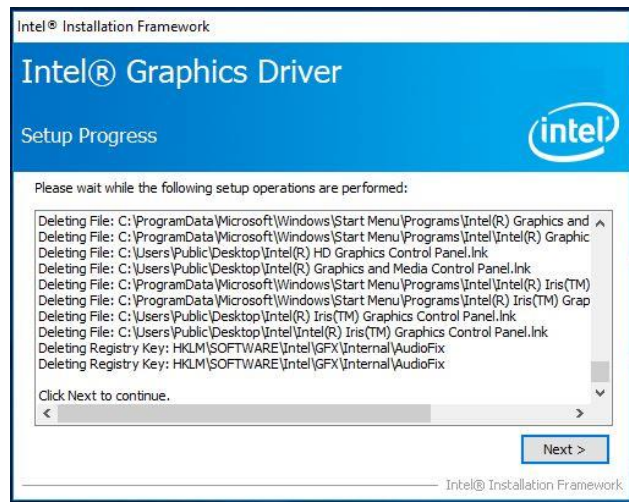

Step 4. Click Next.

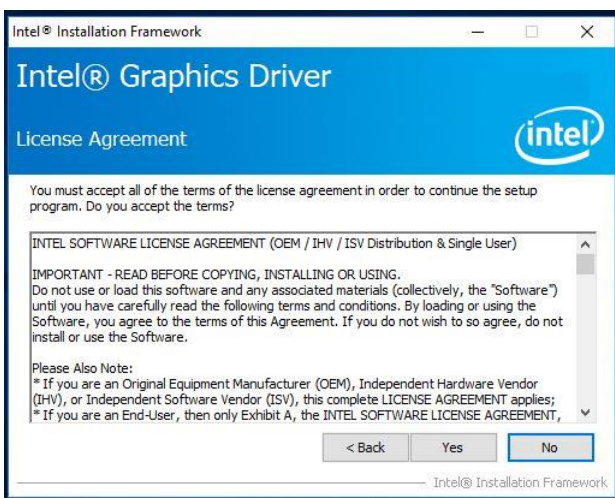

Step 2. Click Yes to accept license agreement.

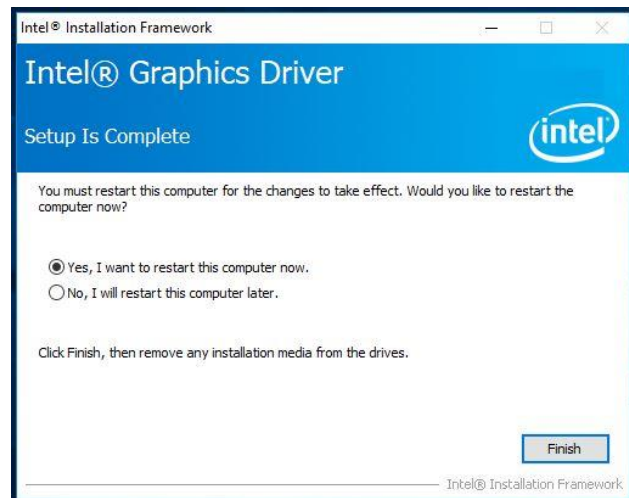

Step 5. Click Finish to complete setup.

4.3 Install LAN Driver (For Intel I219LM)

Insert the Supporting DVD-ROM to DVD-ROM drive, and it should show the index page of our products automatically. If not, locate Index.htm and choose the product from the menu left, or link to [/Driver_Gigabit/Intel//I219LM/ESM-KBLH_KBLA_LAN](#).



Note: The installation procedures and screen shots in this section are based on Windows 10 operation system.



Step 3. Click Next.

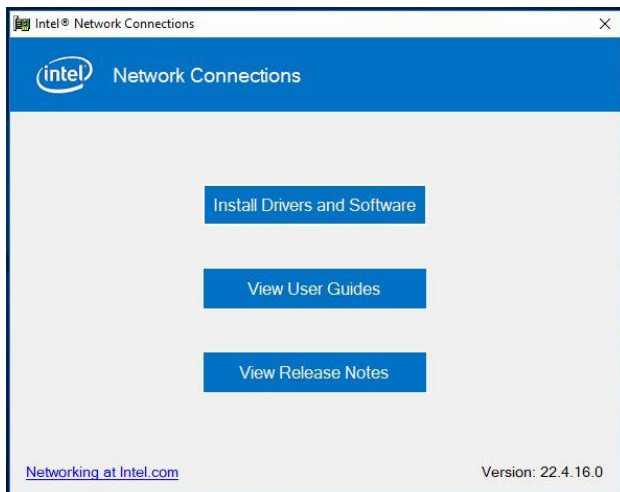

Step 1. Click Install Drivers and Software.

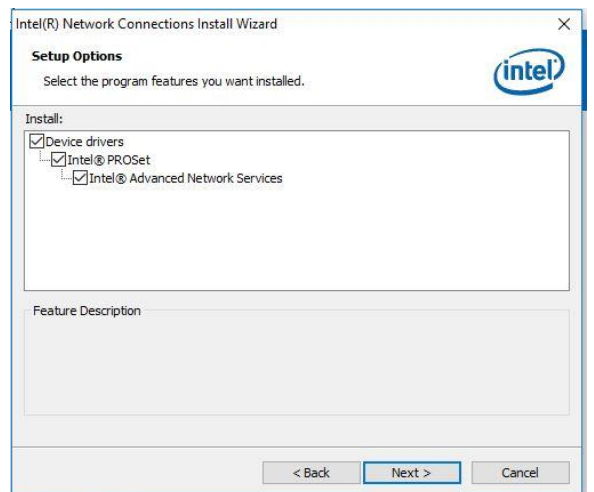

Step 4. Click Next.

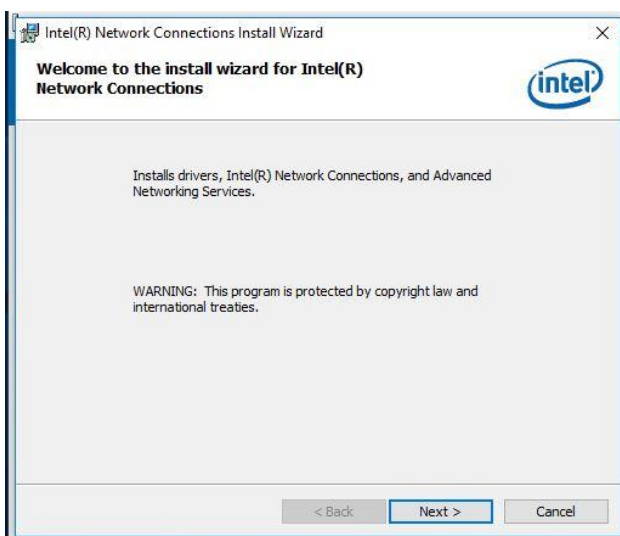

Step 2. Click Next to complete setup.

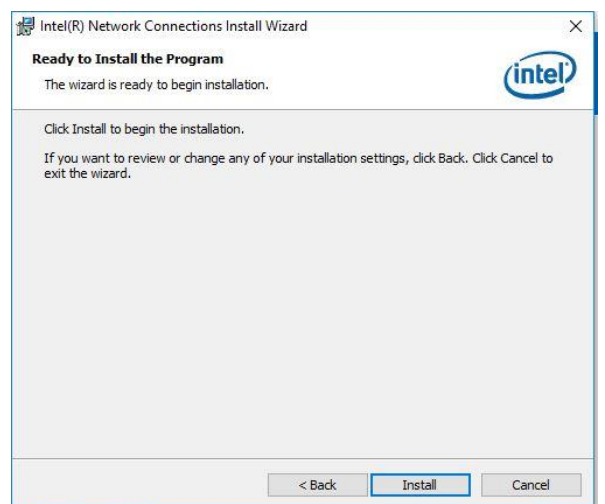

Step 5. Click Install.

ESM-KBLA User's Manual

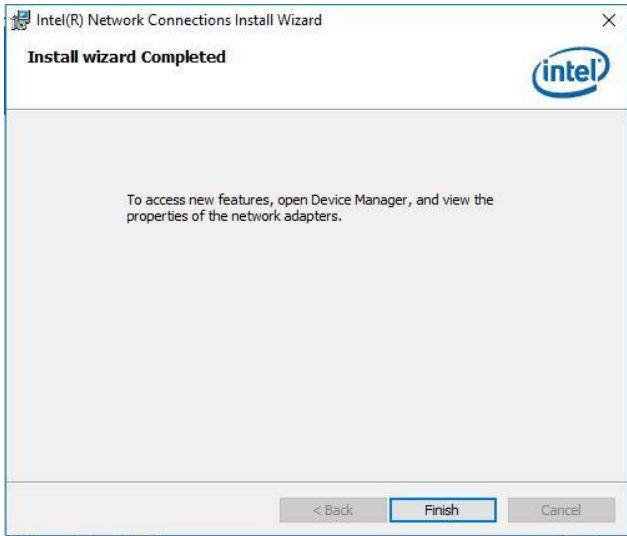

Step 6. Click **Finish** to complete setup.

4.4 Install ME Driver

Insert the Supporting DVD-ROM to DVD-ROM drive, and it should show the index page of our products automatically. If not, locate Index.htm and choose the product from the menu left, or link to / Utility/ESM-KBLH_KBLA_ME.



Note: The installation procedures and screen shots in this section are based on Windows 10 operation system. If the warning message appears while the installation process, click Continue to go on.

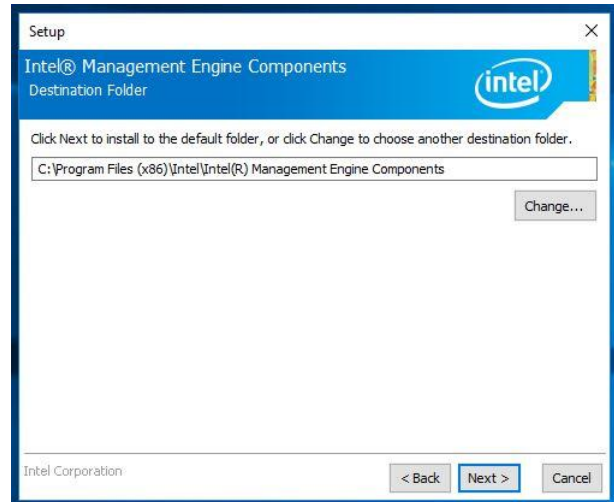

Step 3. Click Next.

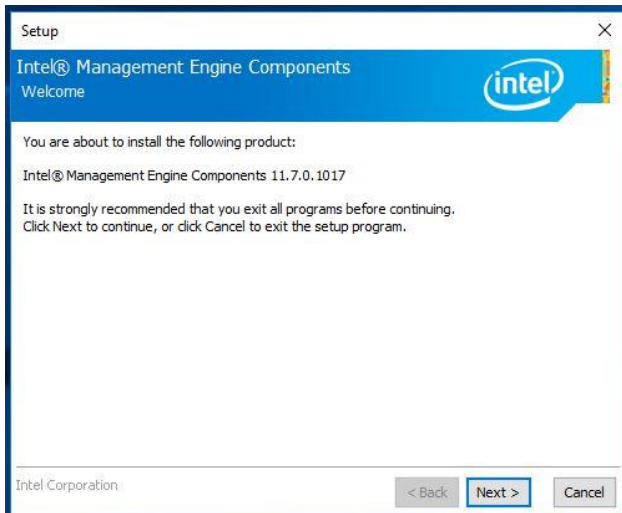

Step1. Click Next to start installation.

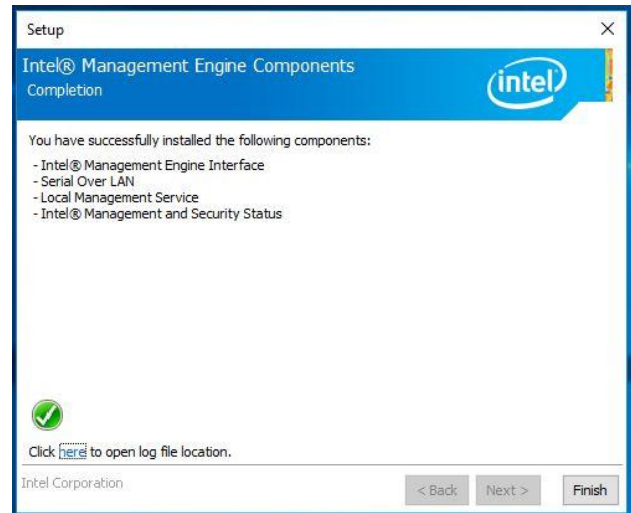

Step 4. Click Finish to complete setup.

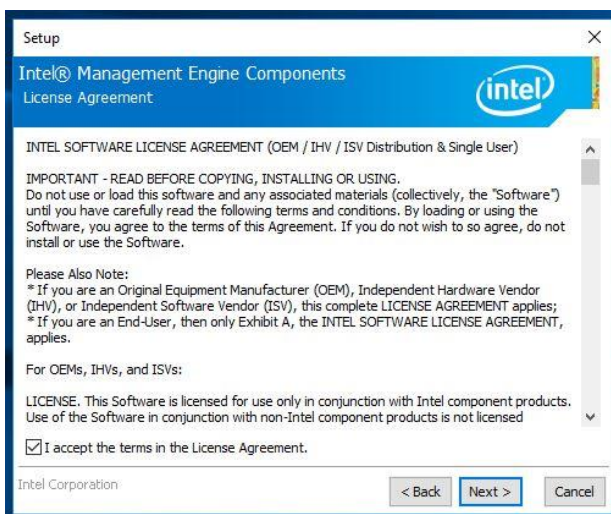

Step 2. Click Next.

4.5 Install Serial IO Driver

Insert the Supporting DVD-ROM to DVD-ROM drive, and it should show the index page of our products automatically. If not, locate Index.htm and choose the product from the menu left, or link to **/Utility/ESM-KBLH_KBLA_SerialIO**.



Note: The installation procedures and screen shots in this section are based on Windows 10 operation system.

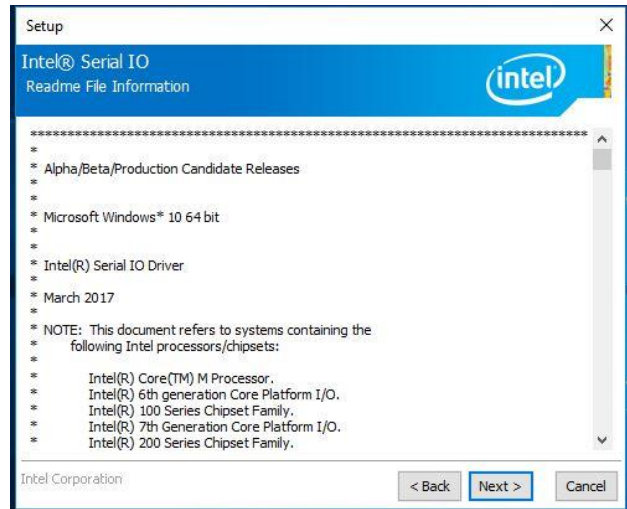

Step 3. Click Next.

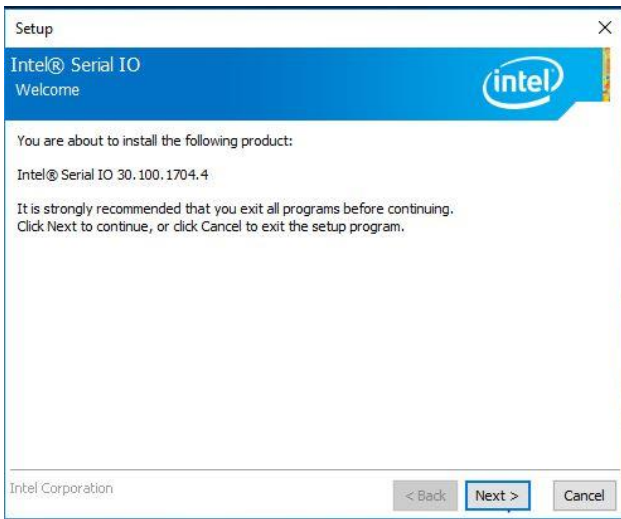

Step 1. Click Next to continue installation.

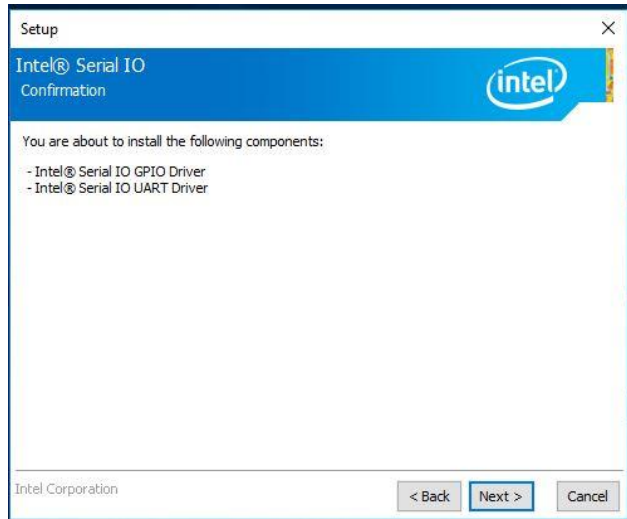

Step 4. Click Next.

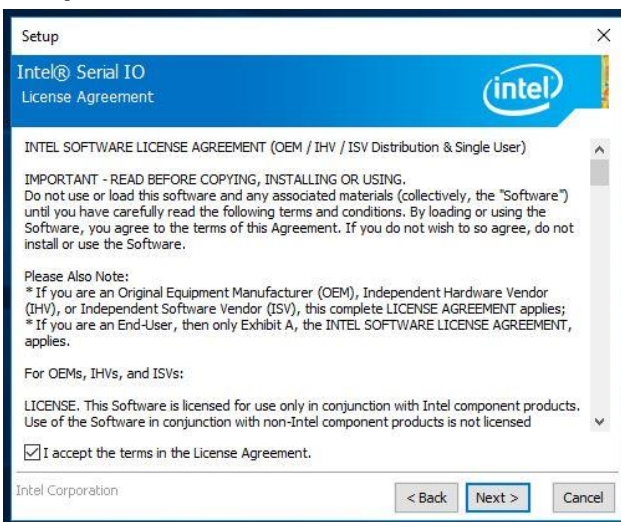

Step 2. Click Next.



Step 5. Click Finish to complete setup.

5. Mechanical Drawing



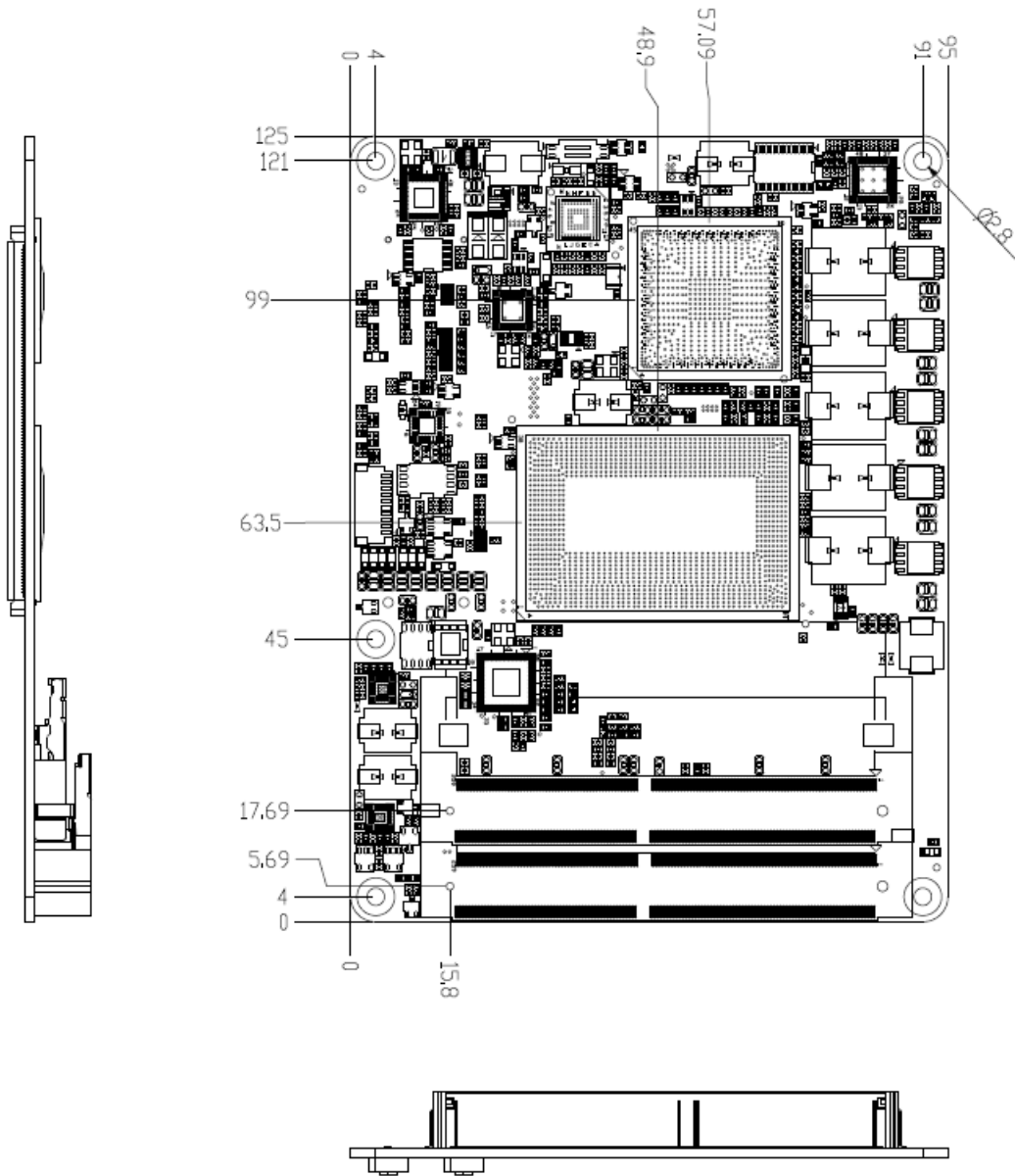

Unit: mm

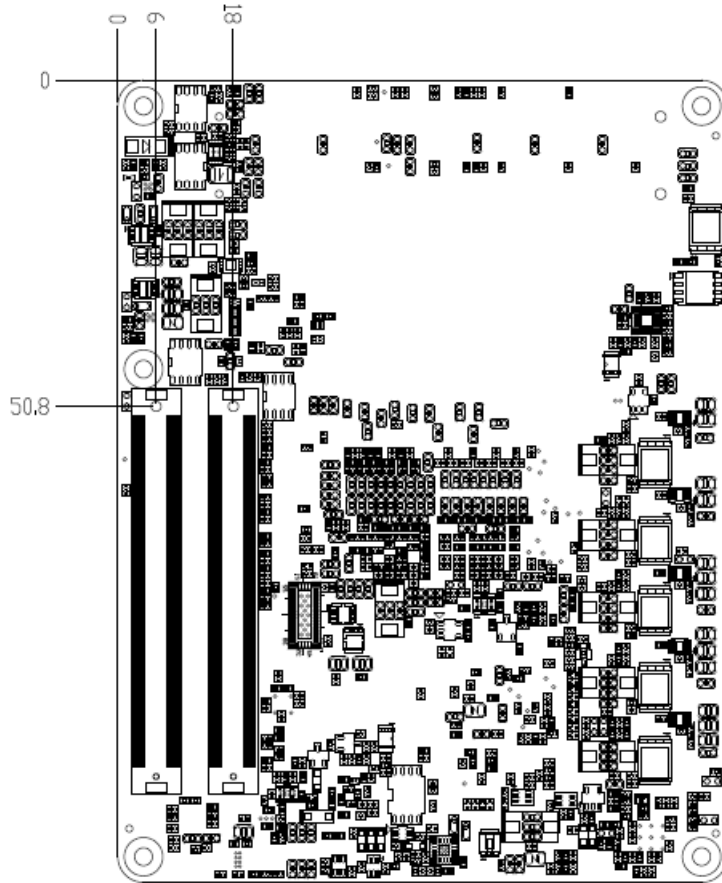

Unit: mm