

Board Layout

Top View

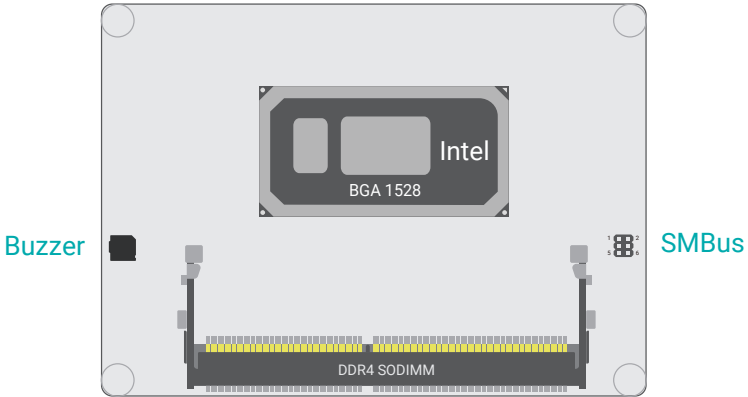

Bottom View

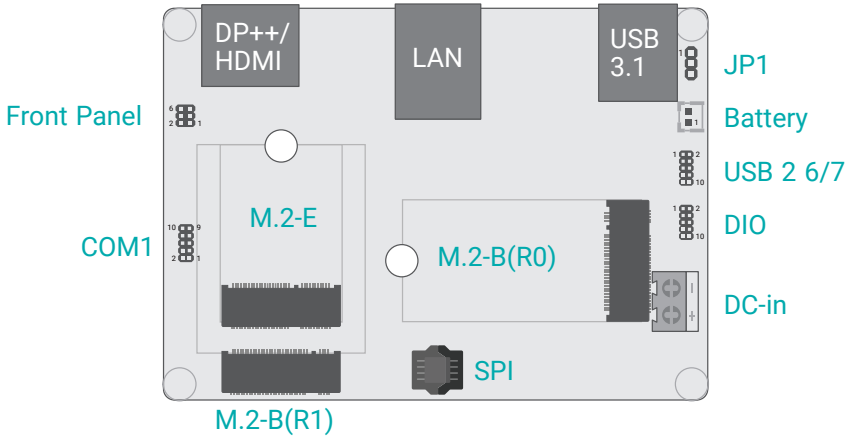

Jumper Settings

Clear CMOS (JP1)



1-2 On: Normal (default)



2-3 On: Clear CMOS

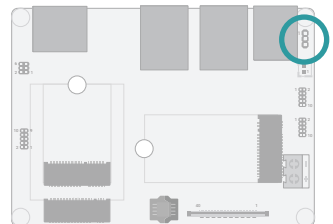

Pin Assignments

SMBus



Pin	Assignment	Pin	Assignment
1	3V3SB	2	GND
3	SMB_HOST_3V3STBY_CLK	4	SMB_HOST_3V3STBY_SDA
5	SMBALERT_N	6	--

USB 6/7 (USB 2.0)

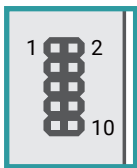

Pin	Assignment	Pin	Assignment
1	5V_USB6_7	2	5V_USB6_7
3	USB2_6_C_N	4	USB2_7_C_N
5	USB2_6_C_P	6	USB2_7_C_N
7	GND	8	GND
9	--	10	--

DIO

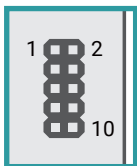

Pin	Assignment	Pin	Assignment
1	D_IOA7_C	2	D_IOA6_C
3	D_IOA5_C	4	D_IOA4_C
5	D_IOA3_C	6	D_IOA2_C
7	D_IOA1_C	8	D_IOA0_C
9	5V	10	GND

COM1

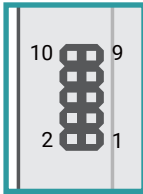

Pin	Assignment
1	MDCD1#
2	MSIN1
3	MSOUT1
4	MDTR1#
5	GND
6	MDSR1#
7	MRTS1#
8	MCTS1#
9	MRI1#
10	GND

Front Panel



Pin	Assignment	Pin	Assignment
1	SIO_PWSIN#	2	3V3SB
3	GND	4	GND
5	SYS_RESET-	6	HD_LED