



# S4

1U Server Passive Cooler

**PRODUCT SPECIFICATIONS**

## Table of Contents

1. PRODUCT DESCRIPTION .....	2
2. THERMAL PERFORMANCE CURVE.....	2
3. EP DRAWING .....	3
4. DM DRAWING .....	4
5. ROHS CERTIFICATE .....	5

## Model Number : S4

- Intel® Sapphire Rapids CPU
- Processor Socket FCLGA4677
- Passive Cooler for 1U Server or up

## Overall Specification

Dimension	118 x 78 x 27mm
Weight	520 g
Material	Copper1100 for both Vapor Chamber Base and Fin Stack
Mounting Sets	Intel standard Anti-Tilt Rotating heat sink captive mounting sets
Package Carrier	PHM Package Carrier is included
Thermal Grease	Shin-Etsu 7762 pre-printed
TDP	Support CPU Power up to 205 Watts Heat Dissipation

## Performance Chart: Passive Cooler S4 Thermal Resistance VS. Airflow

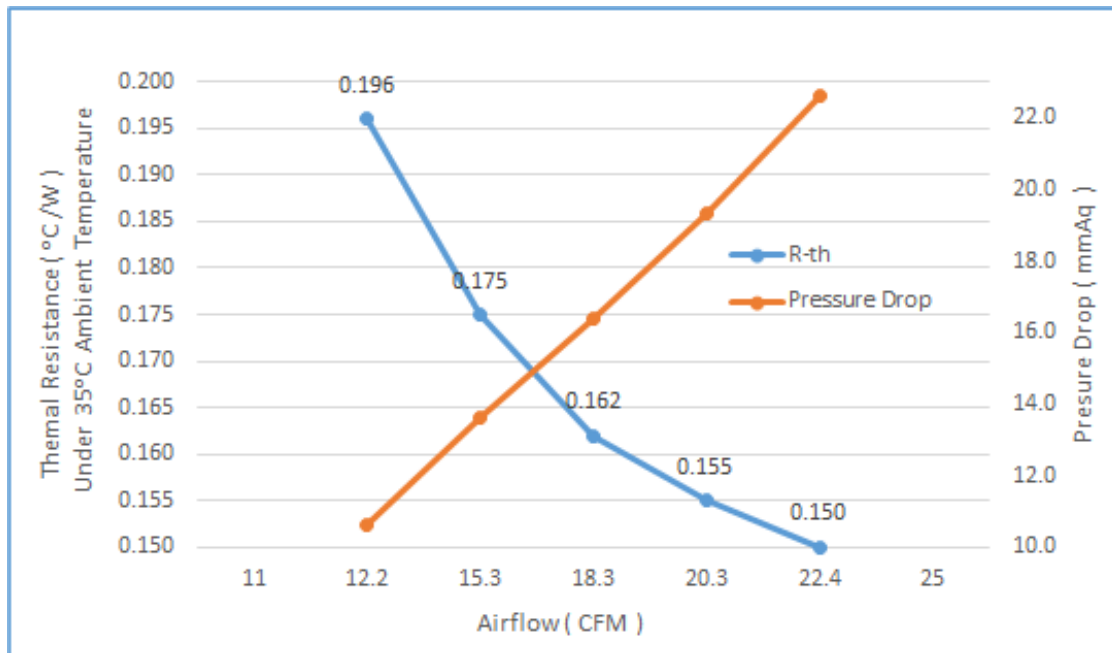

(Tested by Intel Sapphire Rapids TTV)

**CONFIDENTIAL DOCUMENT**

THIS DRAWING CONTAINS INFORMATION PROPRIETARY TO DYNATRON CORPORATION AND DYNAEON INDUSTRIAL CO., LTD. ANY REPRODUCTION, DISCLOSURE, OR USE OF THIS DRAWING IS EXPRESSLY PROHIBITED EXCEPT AS DYNATRON CORPORATION AND DYNAEON INDUSTRIAL CO., LTD. MAY OTHERWISE AGREE TO IN WRITING.

REV#	DESCRIPTION	CHECKER	DATE
0.0	INITIAL RELEASE	LANG	03/26/2021

**ASSEMBLY PARTS**

**WHOLE SET OF HEATSINK**

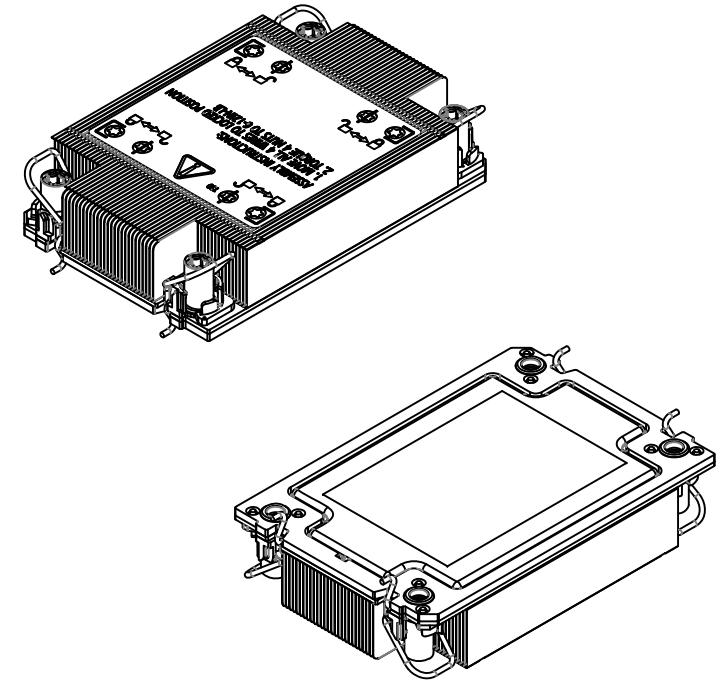
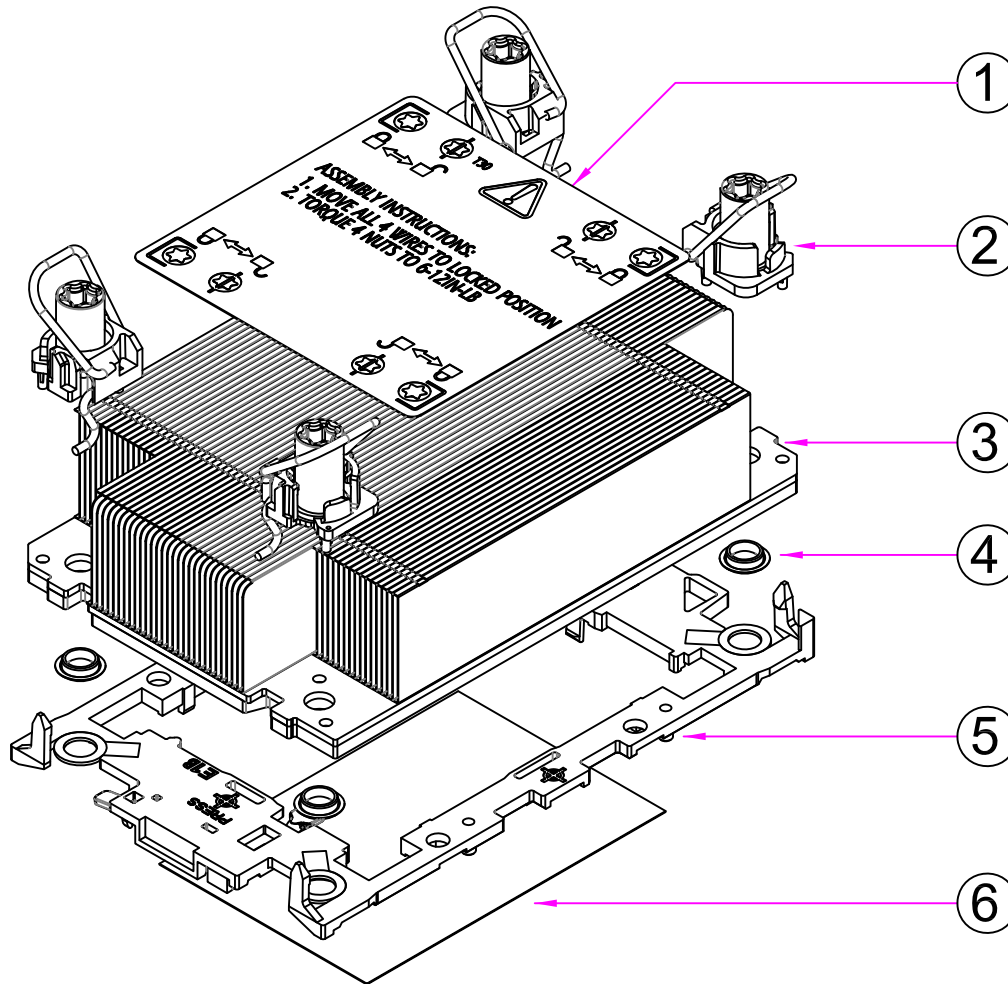

**NOTES:**

1. THE FIGURE IS FOR REFERENCE ONLY, AND NOT FOR SCALE
2. OVERALL DIMENSION : 118 x 78 x 27 mm
3. OVERALL WEIGHT : 520 g

ITEM#	DESCRIPTION	MATERIAL	QTY.
6	THERMAL GREASE, PRE-PRINTED	SHIN-ETSU 7762	1
5	INTEL PACKAGE CARRIER	PLASTIC	1
4	SPACER RING	PLASTIC	4
3	HEATSINK, with STACKED FINS	COPPER FIN STACK COPPER VAPOR CHAMBER BASE STEEL RETENTION	1
2	ANTI-TILT ROTATING WIRE ASSEMBLY SET	PLASTIC NUT AND CAPTIVATION STEEL ROTATING WIRE	4
1	MOUNTING INSTRUCTION LABEL	PLASTIC	1

DATE	NAME	DYNATRON CORPORATION	
03/26/2021	Engr	 <b>TITLE:</b> 1U Passive Cooler Model <b>S4</b> BOM & Exploded Assembly Drawing	
03/26/2021	LANG		
COMMENTS:		DWG. No:	REV
		<b>DYN-EP-S4</b>	<b>0.0</b>

1 2 3 4 5 6 7

REV#	DESCRIPTION	CHECKER	DATE
0.0	INITIAL RELEASE	LANG	03/26/2021

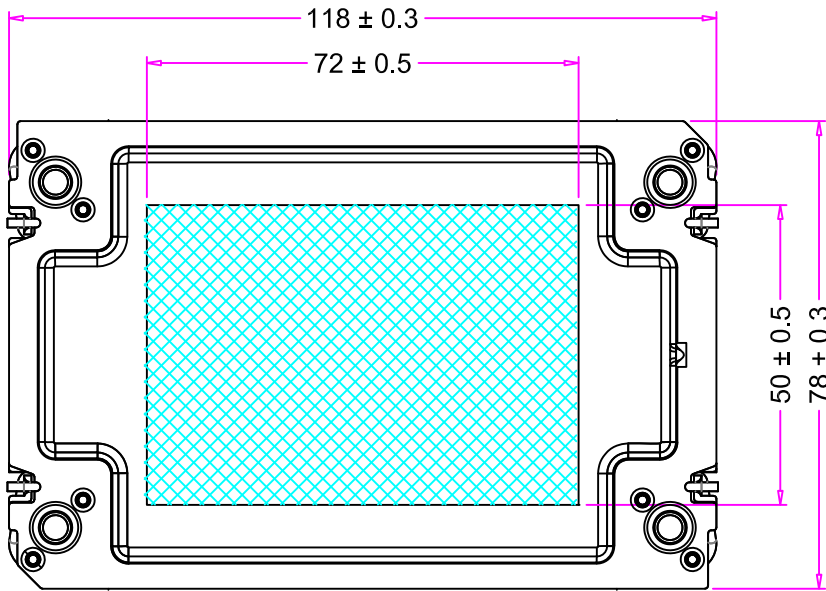
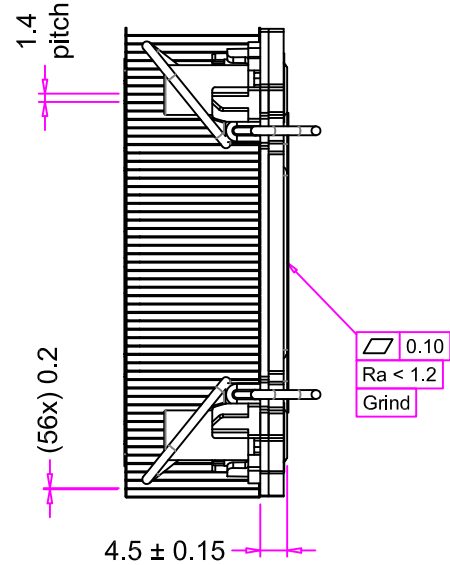
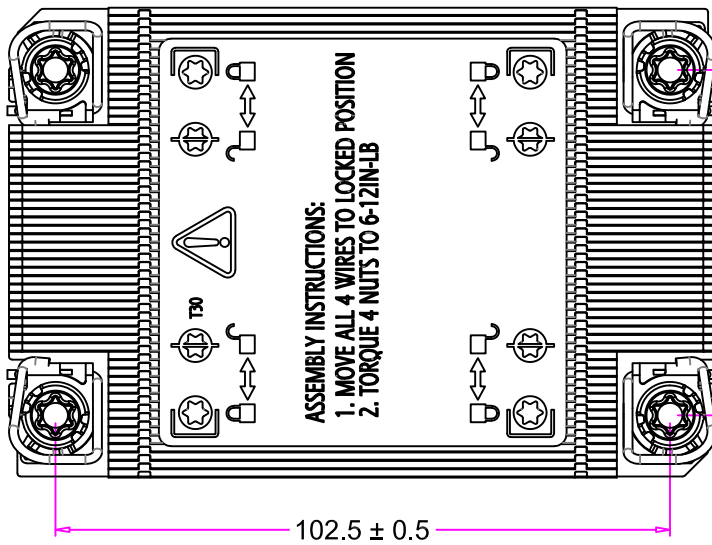

	NAME	DATE
DRAWN BY	engr	03/26/2021
CHECKED BY	LANG	03/26/2021
ENG. APPROVED		
MFG. APPROVED	-	-



**DYNATRON CORPORATION**

TOP MOTOR

TITLE: 1U Passive Cooler Model **S4**  
 Overall Dimension Drawing

**CONFIDENTIAL DOCUMENT**

THIS DRAWING CONTAINS INFORMATION PROPRIETARY TO DYNATRON CORPORATION AND DYNAEON INDUSTRIAL CO., LTD. ANY REPRODUCTION, DISCLOSURE, OR USE OF THIS DRAWING IS EXPRESSLY PROHIBITED EXCEPT AS DYNATRON CORPORATION AND DYNAEON INDUSTRIAL CO., LTD. MAY OTHERWISE AGREE TO IN WRITING.

VIEW	
UNITS	MM

DWG. No:

**DYN-DM-S4**

REV. **1.0**

1 2 3 4 5 6 7