

Q2

2U Passive Heat Sink

PRODUCT SPECIFICATIONS

Model Number: Q2

- Recommend for Intel® CPU as following
 - Intel® Alder Lake S Processor, Socket LGA 1700;
- Passive Heat Sink for 2U Server

Overall Specification

Dimension	90 x 90 x 66 mm
Weight	653±5 g
Material	Copper Base with Aluminum Stacked Fin plus 4 Heat Pipes
Back Strip	Included
Thermal Grease	Pre-Printed with SHIN-ETSU 7762
TDP	Support 150 Watts CPU Power Heat Dissipation

Performance Chart: Q2 Thermal Resistance Thermal Performance vs. Airflow

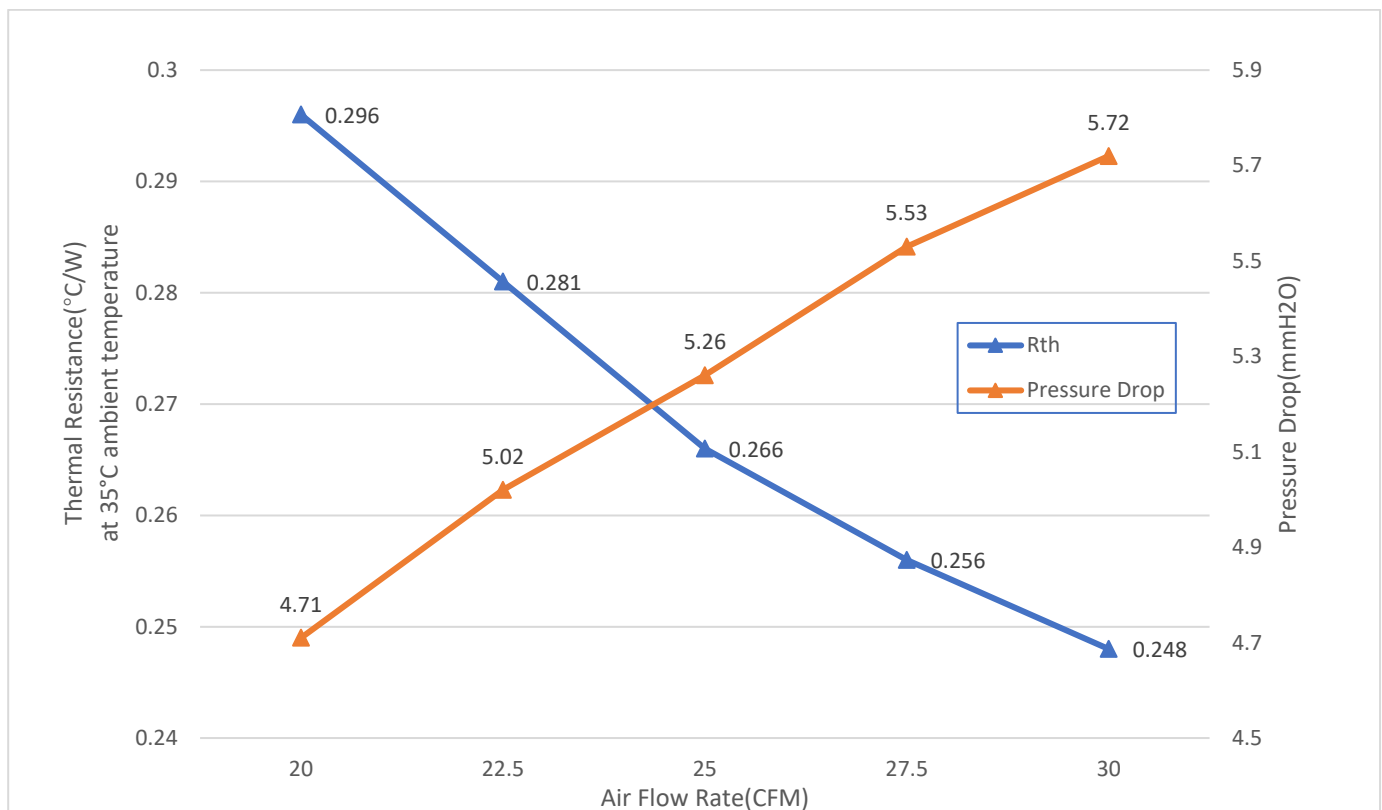

CONFIDENTIAL DOCUMENT

THIS DRAWING CONTAINS INFORMATION PROPRIETARY TO DYNATRON CORPORATION AND DYNAMEN INDUSTRIAL CO., LTD. ANY REPRODUCTION, DISCLOSURE, OR USE OF THIS DRAWING IS EXPRESSLY PROHIBITED EXCEPT AS DYNATRON CORPORATION AND DYNAMEN INDUSTRIAL CO., LTD. MAY OTHERWISE AGREE TO IN WRITING.

REV#	DESCRIPTION	CHECKER	DATE
0.0	INITIAL RELEASE	JOY	02/24/21
1.0	BACKPLATE UPDATE	JOY	10/07/21

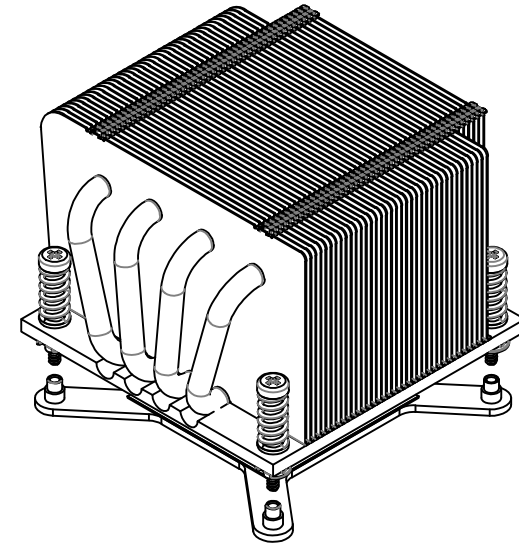
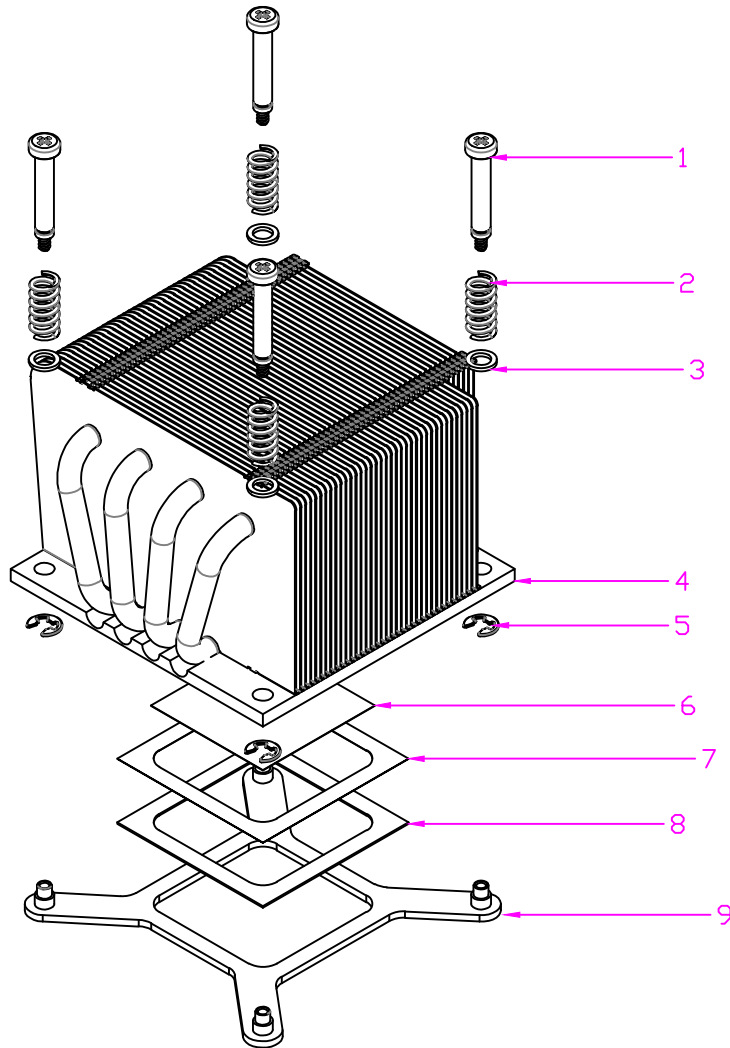

ITEM #	DESCRIPTION	MATERIAL	QTY.
9	BACKPLATE	SPCC	1
8	INSULATOR	FORMEX GK-17	1
7	ADHESIVE TAPE	3M	1
6	THERMAL GREASE	TIG830SP	1
5	C-RING	STEEL	4
4	HEATSINK	Cu Base + AL FIN + HEATPIPE x4	1
3	WASHER	STEEL	4
2	SPRING	SUS 304	4
1	SCREW, HEATSINK	STEEL	4

NOTES:

1. OVERALL DIMENSION: 90.0x90.0x66.0 mm
2. THE FIGURE IS FOR REFERENCE ONLY, AND NOT FOR SCALE

		 DYNATRON CORPORATION	
DRAWN	04/21/21	enr.	TITLE: 2U Passive Cooler Q2 BOM & Exploded Assembly Drawing
CHECKED	04/21/21	Joy	
ENG. APPR.			
MFG. APPR.			
DATE		NAME	
DWG. No:		REV	
DYN-EP-Q2		1.0	

REV#	DESCRIPTION	CHECKER	DATE
0.0	INITIAL RELEASE	JDY	05/04/85
1.0	BACKPLATE UPDATE	JDY	10/07/85

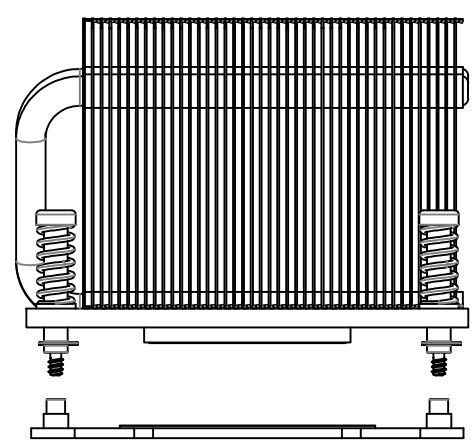
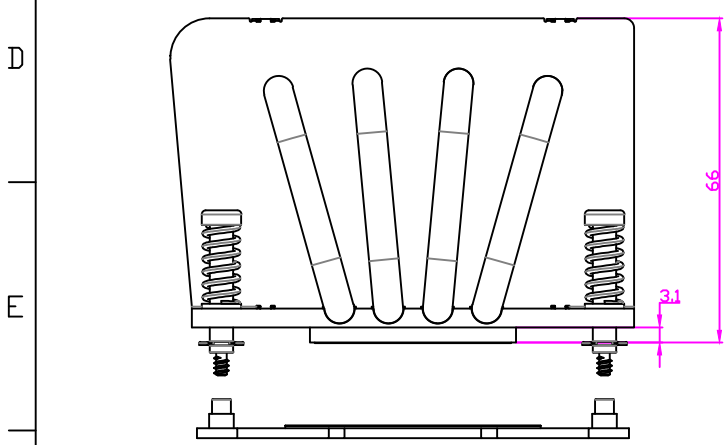
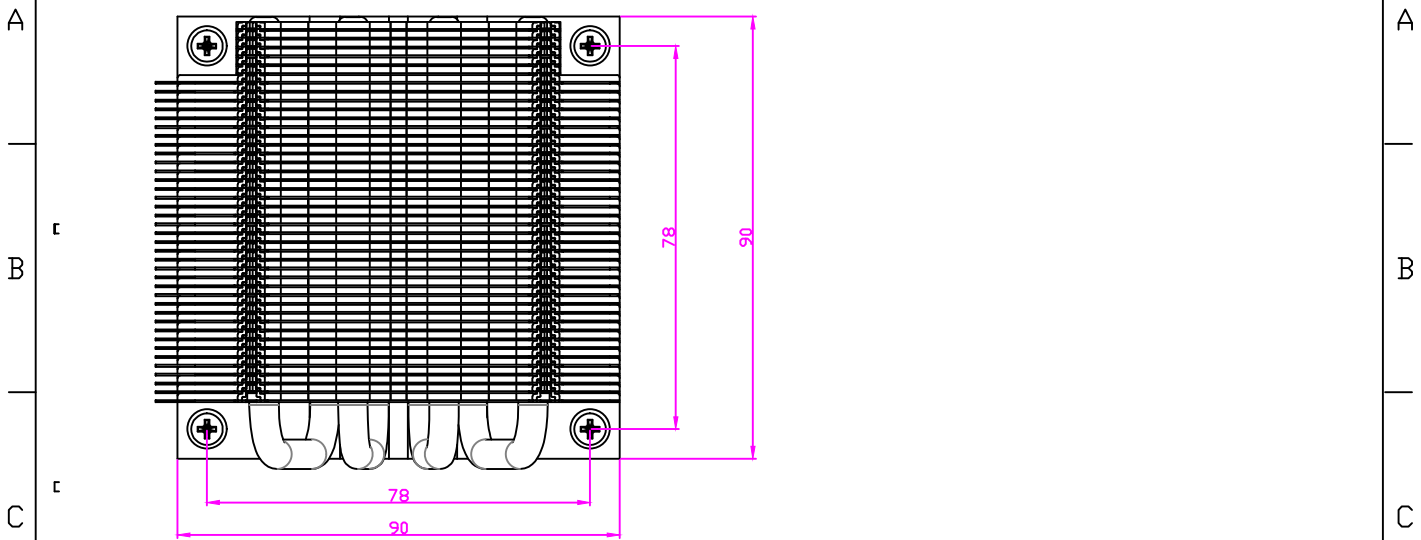

	NAME	DATE
DRAWN BY	ENGR	04/21/2021
CHECKED BY	ENGR	04/21/2021
ENG. APPROVED		
MFG. APPROVED	-	-



DYNATRON CORPORATION

TITLE: 2U PASSIVE COOLER
Q2
Overall Dimension Drawing

CONFIDENTIAL DOCUMENT
THIS DRAWING CONTAINS INFORMATION PROPRIETARY TO DYNATRON CORPORATION AND DYNAEON INDUSTRIAL CO., LTD. ANY REPRODUCTION, DISCLOSURE, OR USE OF THIS DRAWING IS EXPRESSLY PROHIBITED EXCEPT AS DYNATRON CORPORATION AND DYNAEON INDUSTRIAL CO., LTD. MAY OTHERWISE AGREE TO IN WRITING.

VIEW		DWG. No:	REV.
UNITS	MM	DYN-BD-Q2	1.0