

USB Drive 2ME2

Customer: _____

Customer

Part Number: _____

Innodisk

Part Number: _____

Innodisk

Model Name: _____

Date: _____

Innodisk Approver	Customer Approver

**The Total Solution For
Industrial Flash Storage**

Table of contents

TABLE OF CONTENTS	2
LIST OF FIGURES	4
LIST OF TABLES	5
1. PRODUCT OVERVIEW	6
1.1 INTRODUCTION OF USB DRIVE	6
1.2 PRODUCT VIEW	6
1.3 PRODUCT MODELS	6
1.4 CAPACITY	6
1.5 VID/PID	6
2. THEORY OF OPERATION	7
2.1 OVERVIEW	7
2.2 ERROR DETECTION AND CORRECTION	7
2.3 WEAR-LEVELING	7
2.4 BAD BLOCKS MANAGEMENT	8
3. SPECIFICATIONS	9
3.1 CE AND FCC COMPATIBILITY	9
3.2 ROHS COMPLIANCE	9
3.3 ENVIRONMENTAL SPECIFICATIONS	9
3.4 GOLDEN FINGER	10
3.5 PIN ASSIGNMENT	10
3.7 WEIGHT	12
3.8 PERFORMANCE	12
3.9 NAND FLASH MEMORY	12
3.10 WRITE PROTECTION FUNCTION (OPTIONAL)	12
4. ELECTRICAL SPECIFICATIONS	13
4.1 POWER REQUIREMENT	13
4.2 POWER CONSUMPTION	13
4.3 DEVICE PARAMETERS	13
5. PART NUMBER RULE	14

REVISION HISTORY

Revision	Description	Date
V1.0	First Release	Jan., 2022
V1.1	Update Power Consumption, LBA, & User Capacity	Mar., 2022
V1.2	Update write-protection function info. and PID	Jun., 2022

List of Figures

FIGURE 1: USB DRIVE 2ME2	6
FIGURE 2: USB DRIVE 2ME2 BLOCK DIAGRAM	7
FIGURE 3: USB DRIVE 2ME2 MECHANICAL DIMENSIONS	11
FIGURE 4: USB DRIVE 2ME2 MECHANICAL DIMENSIONS (WITH WRITE-PROTECTION FUNCTION) ...	11

List of Tables

TABLE 1: SHOCK/VIBRATION TESTING FOR USB DRIVE 2ME2	9
TABLE 2: USB DRIVE 2ME2 MTBF.....	10
TABLE 3: USB DRIVE 2ME2 TBW	10
TABLE 4: USB DRIVE 2ME2 PIN ASSIGNMENT	10
TABLE 5: USB DRIVE 2ME2 POWER REQUIREMENT.....	13
TABLE 6: USB DRIVE 2ME2 POWER CONSUMPTION	13
TABLE 7: USB DRIVE 2ME2 DEVICE PARAMETERS.....	13

1. Product Overview

1.1 Introduction of USB Drive

The Innodisk USB Drive products provide high capacity USB flash memory storage that electrically complies with High-speed USB 2.0 interface & backward compatible with USB 1.1. The device features attractive small form factor and the connectivity over USB2.0 and the NAND flash architecture provide a faster data transmission.

1.2 Product View

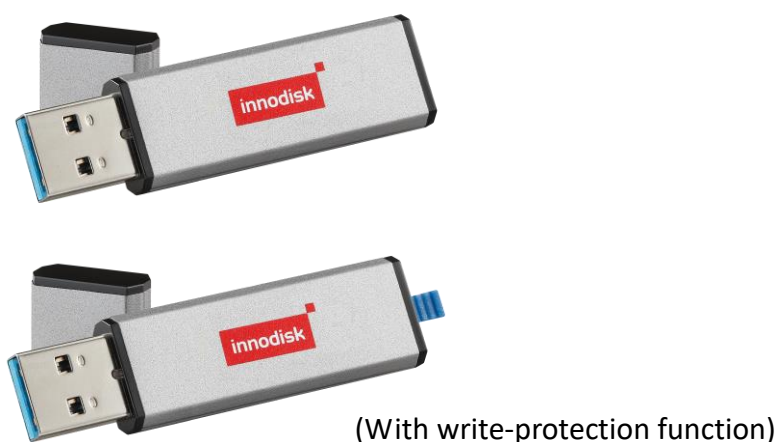

Figure 1: USB Drive 2ME2

1.3 Product Models

USB Drive 2ME2 is available in follow capacities.

- USB Drive 2ME2 8GB
- USB Drive 2ME2 16GB
- USB Drive 2ME2 32GB
- USB Drive 2ME2 64GB

1.4 Capacity

USB Drive 2ME2 provides unformatted from 8GB up to 64GB capacities within MLC Flash IC.

1.5 VID/PID

Customize VID/PID(specify 4bits for each ID, Hexadecimal(0~F)

For Option, Default is 196D/B212.

2. Theory of operation

2.1 Overview

Figure 2 shows the operation of USB Drive 2ME2 from the system level, including the major hardware blocks.

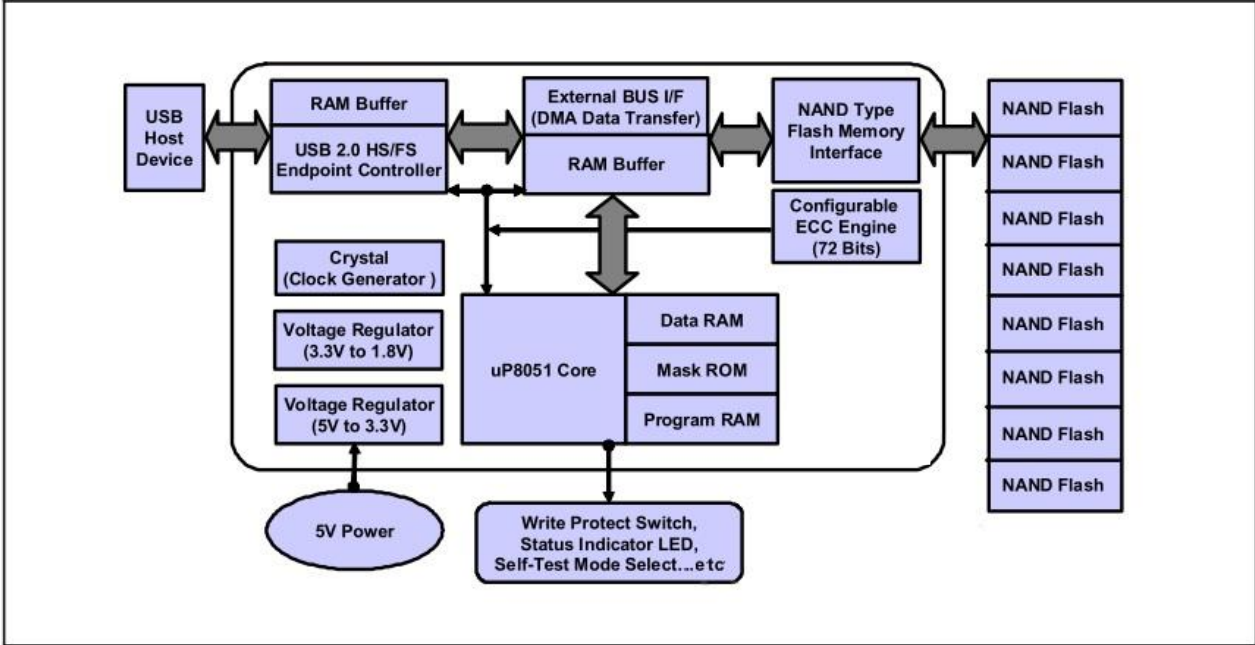

Figure 2: USB Drive 2ME2 Block Diagram

USB Drive 2ME2 integrates a USB2.0 controller and NAND flash memories. Communication with the host occurs through the host interface. Communication with the flash device(s) occurs through the flash interface.

2.2 Error Detection and Correction

Highly sophisticated Error Correction Code algorithms are implemented. The ECC unit consists of the Parity Unit (parity-byte generation) and the Syndrome Unit (syndrome-byte computation). This unit implements an algorithm that can correct 72 bits per 1024 bytes in an ECC block. Code-byte generation during write operations, as well as error detection during read operation, is implemented on the fly without any speed penalties.

2.3 Wear-Leveling

Flash memory can be erased within a limited number of times. This number is called the *erase cycle limit* or *write endurance limit* and is defined by the flash array vendor. The erase cycle limit applies to each individual erase block in the flash device.

USB Drive 2ME2 uses a static wear-leveling algorithm to ensure that consecutive writes of a specific sector are not written physically to the same page/block in the flash. This spreads flash media usage evenly across all pages, thereby extending flash lifetime.

2.4 Bad Blocks Management

Bad Blocks are blocks that contain one or more invalid bits whose reliability are not guaranteed. The Bad Blocks may be presented while the SSD is shipped, or may generate during the life time of the SSD. When the Bad Blocks is detected, it will be flagged, and not be used anymore. The SSD implement Bad Blocks management and replacement, Error Correct Code to avoid data error occurred. The functions will be enabled automatically to transfer data from Bad Blocks to spare blocks, and correct error bit. After the reserved block less than 40, the SSD will be locked, and cannot be written anymore.

3. Specifications

3.1 CE and FCC Compatibility

USB Drive 2ME2 conforms to CE and FCC requirements.

3.2 RoHS Compliance

USB Drive 2ME2 is fully compliant with RoHS directive.

3.3 Environmental Specifications

3.3.1 Temperature Ranges

Operating Temperature Range:

- Standard Grade: 0°C ~ +70°C
- Industrial Grade: -40°C ~ +85°C

Storage Temperature Range:

- Standard Grade: -40°C to +85°C

3.3.2 Humidity

Relative Humidity: 10-95%, non-condensing

3.3.3 Shock and Vibration

Reliability	Test Conditions	Reference Standards
Vibration	7 Hz to 2K Hz, 20G, 3 axes	IEC 68-2-6
Mechanical Shock	Duration: 0.5ms, 1500G, 3 axes	IEC 68-2-27

Table 1: Shock/Vibration Testing for USB Drive 2ME2

3.3.4 Mean Time between Failures (MTBF)

Table 2 summarizes the MTBF prediction results for various USB Drive 2ME2 configurations. The analysis was performed using a RAM Commander™ failure rate prediction.

- Failure Rate: The total number of failures within an item population, divided by the total number of life units expended by that population, during a particular measurement interval under stated condition.
- Mean Time between Failures (MTBF): A basic measure of reliability for repairable items: The mean number of life units during which all parts of the item perform within their specified limits, during a particular measurement interval under stated conditions.

Product	Condition	MTBF (Hours)
USB Drive 2ME2	Telcordia SR-332 GB, 25°C	>3,000,000

Table 2: USB Drive 2ME2 MTBF

3.3.5 Terabyte Written (TBW)

Parameter	Value
TBW (Sequential Write)	Unit: TB
08GB	21.6
16GB	43.2
32GB	86.4
64GB	172.80

Table 3: USB Drive 2ME2 TBW

3.4 Golden finger

30μ"

3.5 Pin Assignment

USB Drive 2ME2 is designed within USB2.0 Interface. Particularly, its built-in power pin enables the device more compactable. Table 4 demonstrates USB Drive 2ME2 pin assignments.

Pin No.	Name	Description
1	VBUS	+5V
2	D-	Data -
3	D+	Data +
4	GND	Ground

Table 4: USB Drive 2ME2 Pin Assignment

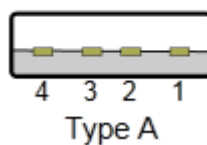

3.6 Mechanical Dimensions

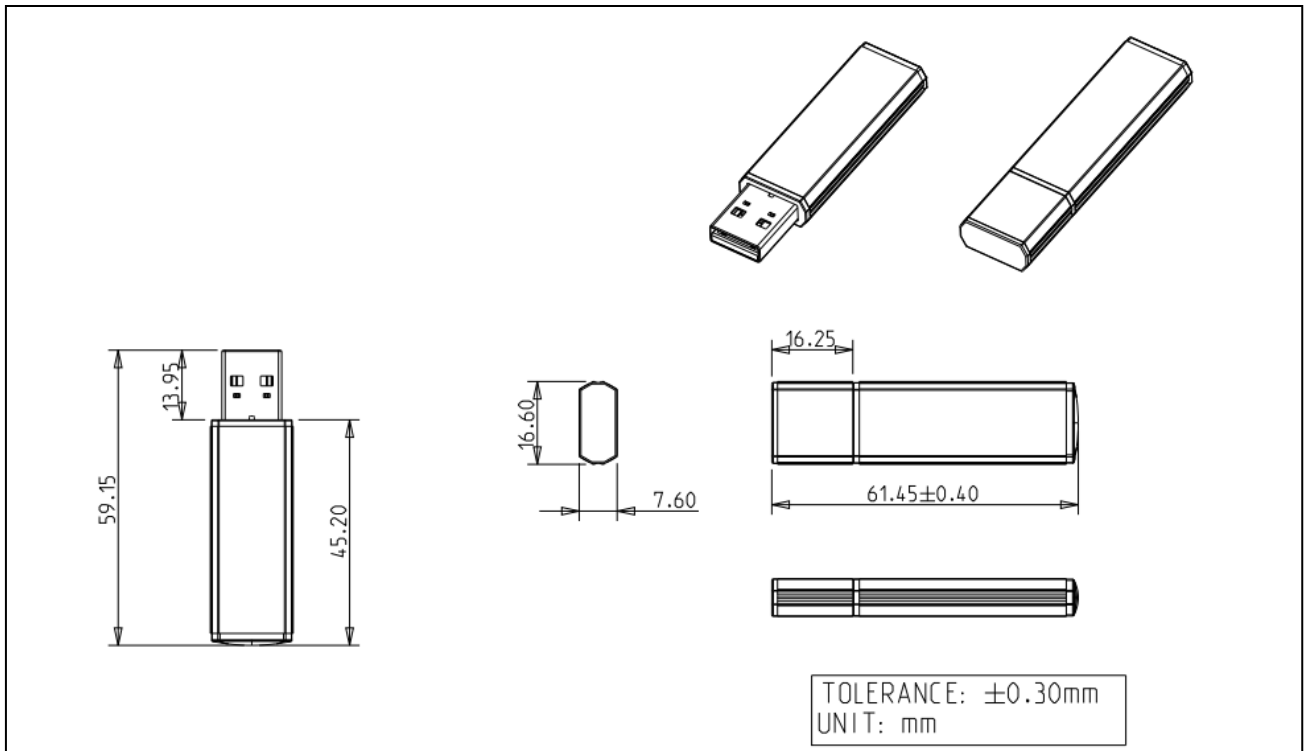

Figure 3: USB Drive 2ME2 mechanical dimensions

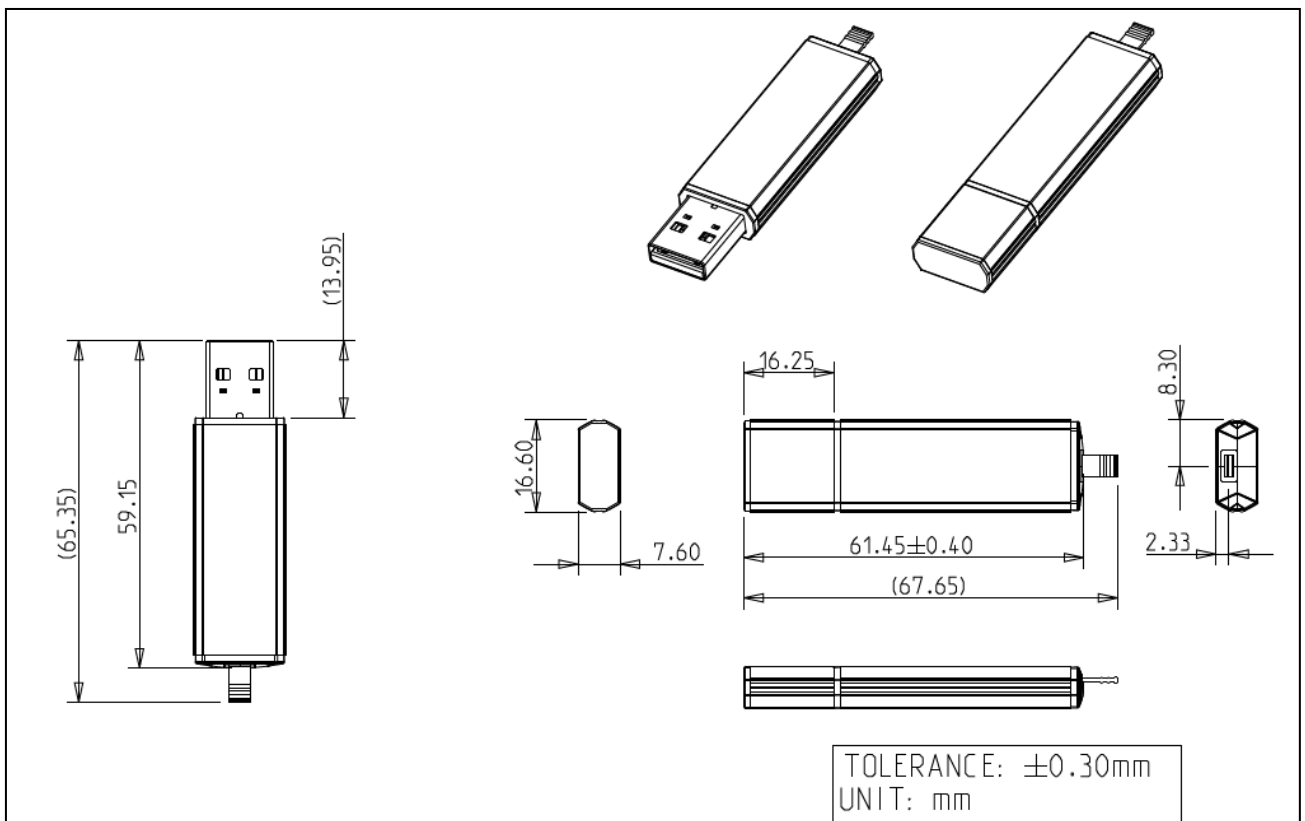

Figure 4: USB Drive 2ME2 mechanical dimensions (with write-protection function)

3.7 Weight

10g±2

3.8 Performance

Product name		Unit	8GB	16GB	32GB	64GB
USB Drive 2ME2 (Max.)	Sequential Read	MB/s	35	35	40	40
	Sequential Write	MB/s	20	20	25	30

3.9 NAND Flash Memory

USB Drive 2ME2 uses Multi-Level Cell (MLC) NAND flash memory, which is non-volatility, high reliability which has 3,000 program/erase times and high speed memory storage.

3.10 Write Protection function (Optional)

USB Drive 2ME2 provides hardware write-protection (W/P) function that could prevent the device from modification and deletion. Write-protection function is enabled through plugging out W/P Jumper, making write-protected data to be read only, that is, users could not write to it, edit it, append data to it, or delete it. On the contrary, user could insert W/P jumper to disabled write protection function to write, edit or delete data.

Note. For supporting write-protection function, please contact sales for customization.

4. Electrical Specifications

4.1 Power Requirement

Item	Symbol	Rating	Unit
Input voltage	V _{IN}	+5 DC +- 5%	V

Table 5: USB Drive 2ME2 Power Requirement

4.2 Power Consumption

Mode	Power Consumption(W)
Read	0.37
Write	0.43
Idle	0.22
The power consumption is based on 64GB Model.	

Table 6: USB Drive 2ME2 Power Consumption

4.3 Device Parameters

USB Drive device parameters listed in Table 7.

Capacity	LBA	User capacity (MB)
8GB	15649200	7641
16GB	31277232	15272
32GB	62533296	30534
64GB	125045424	61057

Table 7: USB Drive 2ME2 Device parameters

5. Part Number Rule

	1	2	3	4	5	6	7	8	9	10	11	12	13	14	15	16	17	18	19	20
	D	E	U	A	1	-	6	4	G	D	Q	1	B	W	1	S	C			
Description	Disk	Form Factor				-	Capacity			Category			Flash mode	Operation Temp.	PCB Version	Channel	Flash		Customized Code	
Definition																				
Code 1st (Disk)										Code 13th (Flash mode)										
D: Disk										B: Kioxia 15nm MLC										
Code 2nd ~ 5th (Form Factor)										Code 14th (Operation Temperature)										
EUA1: USB Drive										C: Standard Grade (0°C~ +70°C)										
										W: Industrial Grade (-40°C~ +85°C)										
Code 7th ~9th (Capacity)										Code 15th (PCB Version)										
08G:8GB										1~9: TSOP PCB version										
16G:16GB																				
32G:32GB																				
64G:64GB										Code 16th (Channel)										
										S: Single channel										
Code 10th ~12th (Category)										Code 17th (Flash)										
DQ1: USB Drive 2ME2										C: Kioxia MLC										