



# L19

2U Liquid Cooler

**PRODUCT SPECIFICATIONS**

## Table of Contents

1. PRODUCT DESCRIPTION .....	2
2.THERMAL PERFORMANCE CURVE.....	4
3.ASSEMBLY DRAWING .....	.6
4. FAN SPECIFICATION .....	9

## Model Number: L19

- Desktop Liquid Cooling Solution Recommended for CPU Models as Following
  - Intel® Processor, Socket LGA1200
  - Intel® Processor, Socket LGA1151, 1150, 1155, 1156
  - Intel® Processor, Socket LGA1700
  - Intel® Processor, Socket LGA2011, Square ILM Mounting
  - Intel® Processor, Socket LGA2011, Narrow ILM Mounting
  - Intel® Processor, Socket LGA1356, 1366
  - AMD® Processor, Socket FM2, FM1, AM3, AM2+, AM2, AM3, AM4, AM5
- For 2U Server and up

## Overall Specification

- Cold Plate Module with Copper base
- Space-saving lightweight Radiator
- Dual 7 cm Cooling Fans with 4-Pin PWM Function
- Stand-alone Water Pump with Powerful Flow Rate 1.7 Litter Per Minute
- 30 cm Black Pair EPDM Tube Assembled
- Mounting Accessories are included
- Shin-Etsu Series Thermal Compound Pre-Printed on Base
- Support CPU Overclocking Power Mode up to 250 Watts Heat Dissipation

## Fan Specification

Model Number	DF127015BU - PWM
Dimension	70 x 70 x 15 mm
Bearing	Double Ball
Rated Voltage	12V
Rated Speed	At Duty Cycle 0~20%: 3300 ± 10% RPM At Duty Cycle 50%: 4500 ± 10% RPM At Duty Cycle 100%: 6000 ±10% RPM
Input Power	At Duty Cycle 0~20%: 1.80 W At Duty Cycle 50%: 3.24 W At Duty Cycle 100%: 7.92 W
Maximum Airflow	At Duty Cycle 0~20%: 27.43 CFM At Duty Cycle 50%: 37.40 CFM At Duty Cycle 100%: 54.02 CFM
Rated Static Pressure	At Duty Cycle 0~20%: 2.95 mm-H2O At Duty Cycle 50%: 5.49 mm-H2O At Duty Cycle 100%: 11.45 mm-H2O

**L19 | LGA2011 Square/Narrow/1356/1366/115X/1200|AM2/AM2+/AM3/FM1/FM2**

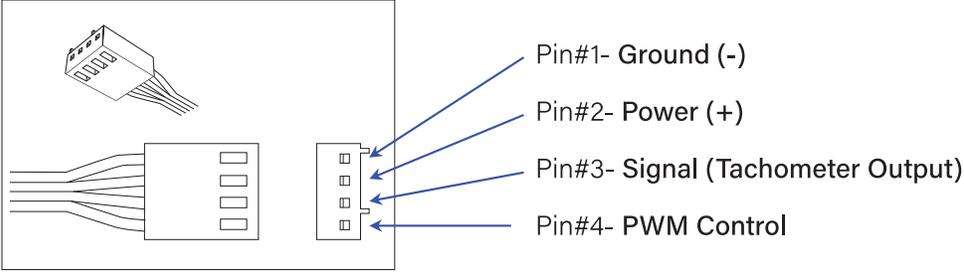
<b>Acoustical Noise</b>	At Duty Cycle 0~20%: 31.70 dBA At Duty Cycle 50%: 38.44 dBA At Duty Cycle 100%: 46.42 dBA
<b>Lead Wire Pin Out Diagram</b>	 <p>Pin#1- Ground (-)          Pin#2- Power (+)          Pin#3- Signal (Tachometer Output)          Pin#4- PWM Control</p>

## L19 Thermal Performance Curve

### Cooling Performance vs. Airflow

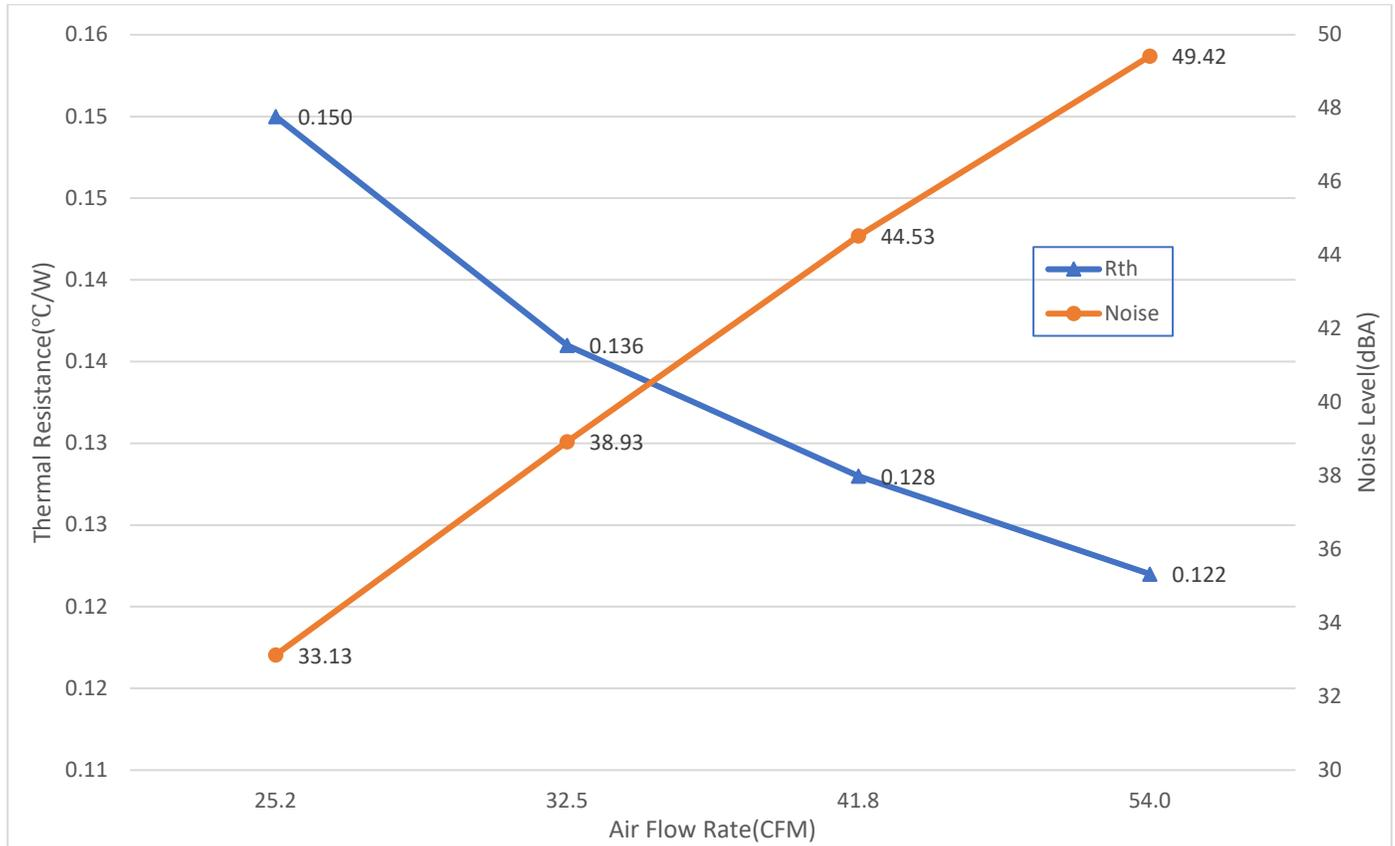

## Cooling Performance vs. Fan Speed

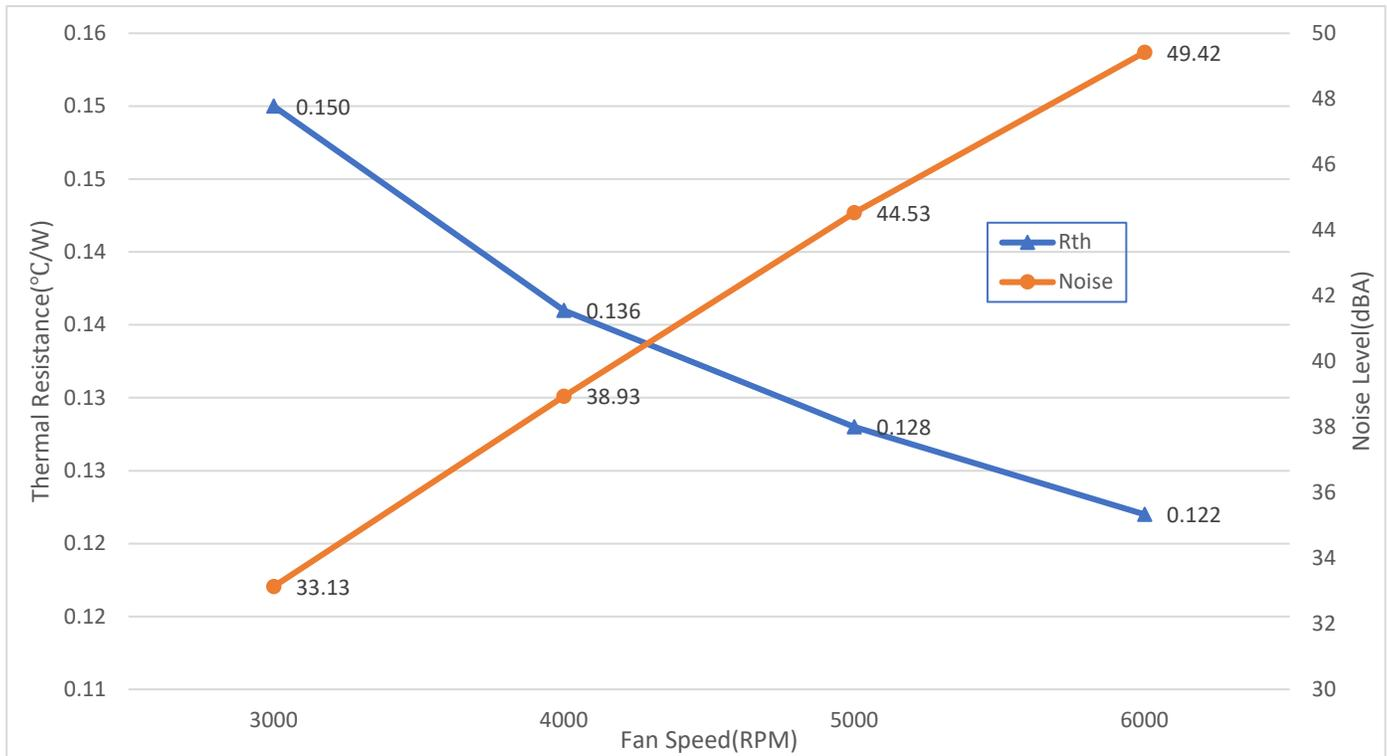

**CONFIDENTIAL DOCUMENT**

THIS DRAWING CONTAINS INFORMATION PROPRIETARY TO DYNATRON CORPORATION AND DYNAEON INDUSTRIAL CO., LTD. ANY REPRODUCTION, DISCLOSURE, OR USE OF THIS DRAWING IS EXPRESSLY PROHIBITED EXCEPT AS DYNATRON CORPORATION AND DYNAEON INDUSTRIAL CO., LTD. MAY OTHERWISE AGREE TO IN WRITING.

REV#	DESCRIPTION	CHECKER	DATE
0.0	INITIAL RELEASE	LANG	04/30/2019

**WHOLE SET OF CONDENSER**

**ASSEMBLY PARTS**

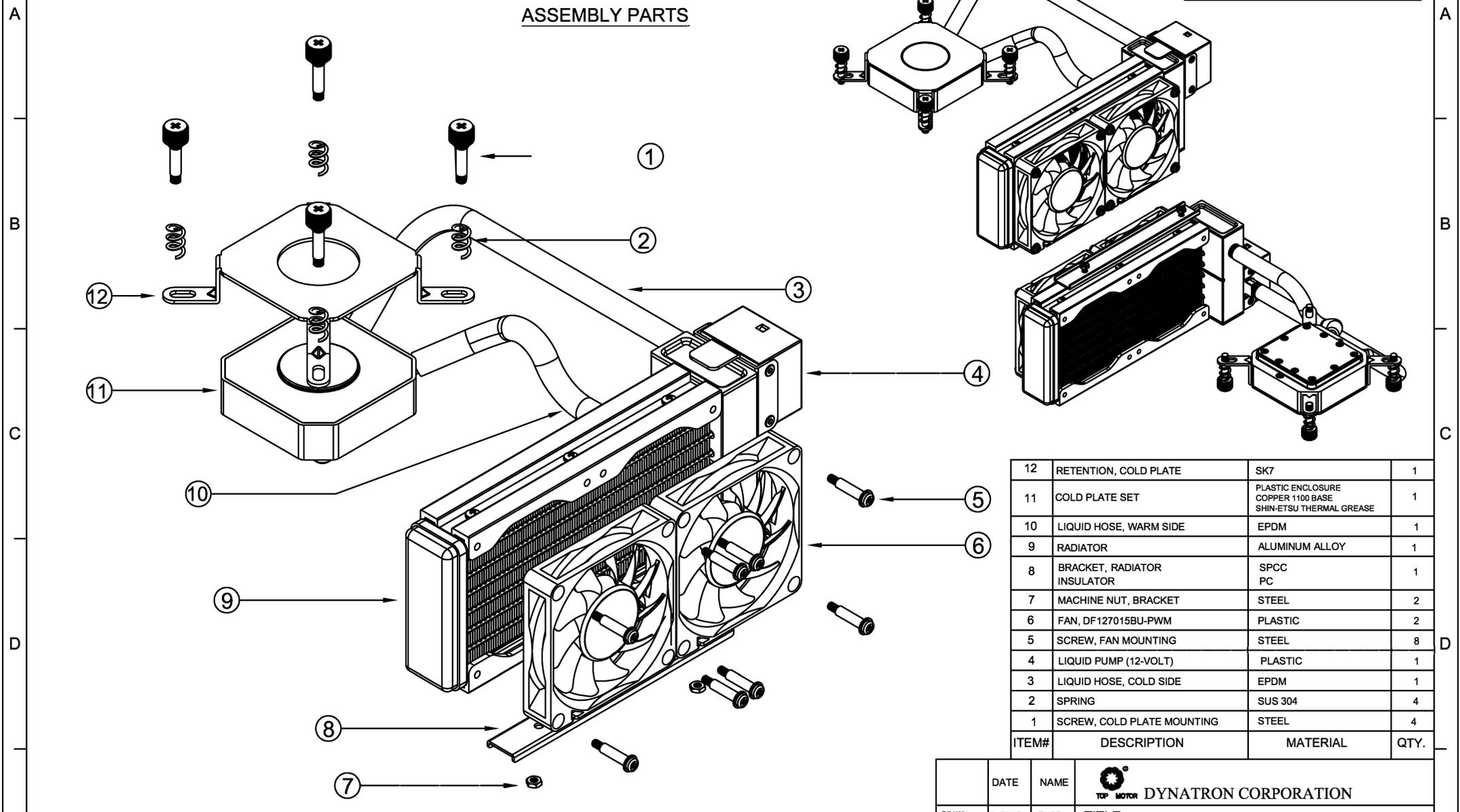

ITEM#	DESCRIPTION	MATERIAL	QTY.
12	RETENTION, COLD PLATE	SK7	1
11	COLD PLATE SET	PLASTIC ENCLOSURE COPPER 1100 BASE SHIN-ETSU THERMAL GREASE	1
10	LIQUID HOSE, WARM SIDE	EPDM	1
9	RADIATOR	ALUMINUM ALLOY	1
8	BRACKET, RADIATOR INSULATOR	SPCC PC	1
7	MACHINE NUT, BRACKET	STEEL	2
6	FAN, DF127015BU-PWM	PLASTIC	2
5	SCREW, FAN MOUNTING	STEEL	8
4	LIQUID PUMP (12-VOLT)	PLASTIC	1
3	LIQUID HOSE, COLD SIDE	EPDM	1
2	SPRING	SUS 304	4
1	SCREW, COLD PLATE MOUNTING	STEEL	4

**Notes:**

1. The Figure is For Reference Only, and Not For Scale
2. Overall Dimension: 204 x 58 x 75 mm

	DATE	NAME	<p><b>DYNATRON CORPORATION</b></p> <p>TITLE: <b>2U Liquid Cooler L19</b> <b>BOM &amp; Exploded Assembly Drawing</b></p>
DRAWN	04/30/19	ENGR	
CHECKED	04/30/19	LANG	
ENG. APPR.			
MFG. APPR.			
Q.A.			
COMMENTS:			
DWG. No:			<b>DYN-EP-L19</b>
			REV <b>0.0</b>

REV#	DESCRIPTION	CHECKER	DATE
0.0	INITIAL RELEASE	LANG	04/30/19
1.0	ADD DIMENSION TOLERANCE	LANG	06/04/19

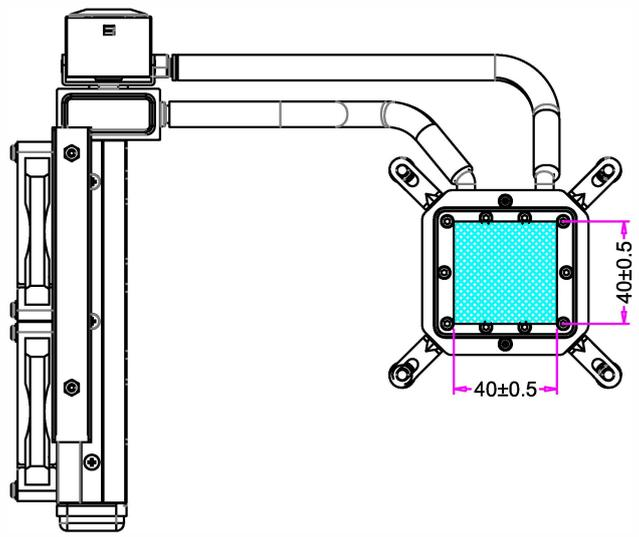
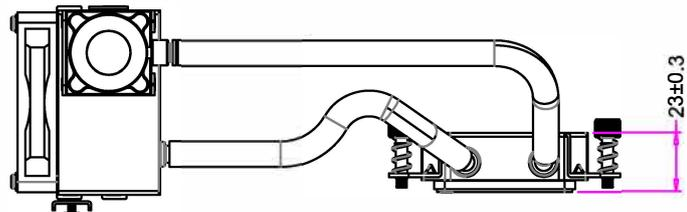
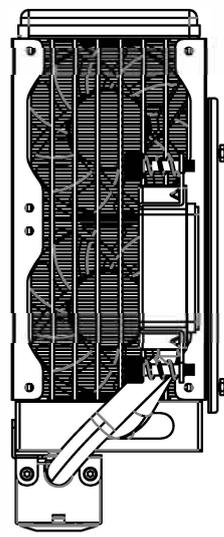
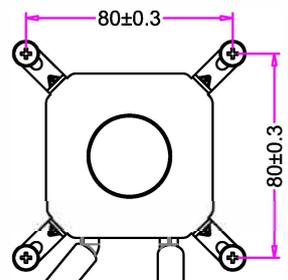
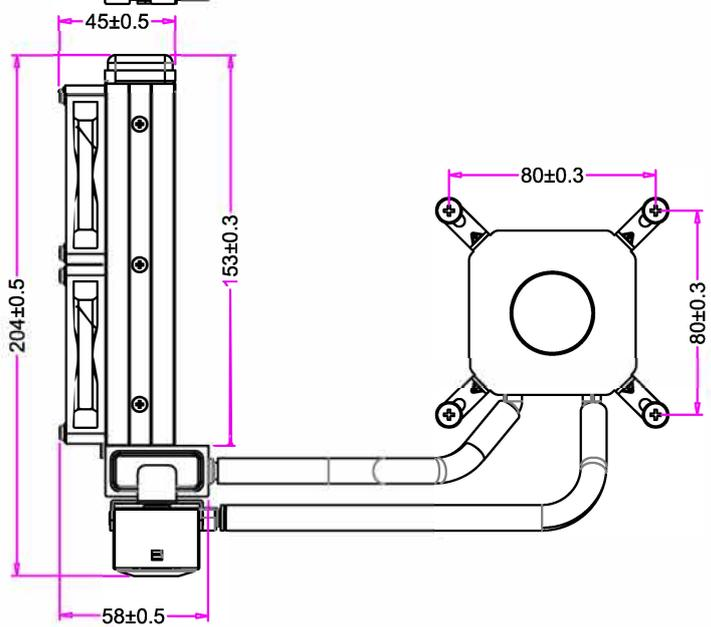
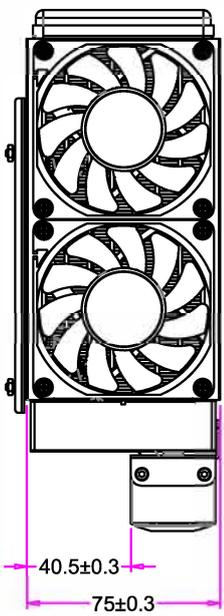

	NAME	DATE
DRAWN BY	ENGR	06/04/2019
CHECKED BY	LANG	06/04/2019
ENG. APPROVED		
MFG. APPROVED	-	-



**DYNATRON CORPORATION**

TITLE: Liquid Cooler L19  
(SNK-P3008A4)  
Overall Dimension Drawing

**CONFIDENTIAL DOCUMENT**  
THIS DRAWING CONTAINS INFORMATION PROPRIETARY TO DYNATRON CORPORATION AND DYNAEDN INDUSTRIAL CO., LTD. ANY REPRODUCTION, DISCLOSURE, OR USE OF THIS DRAWING IS EXPRESSLY PROHIBITED EXCEPT AS DYNATRON CORPORATION AND DYNAEDN INDUSTRIAL CO., LTD. MAY OTHERWISE AGREE TO IN WRITING.

VIEW	DWG. No:	REV.
UNITS	DYN-DM-L19	1.0

1 2 3 4 5 6 7

# DIMENSION:

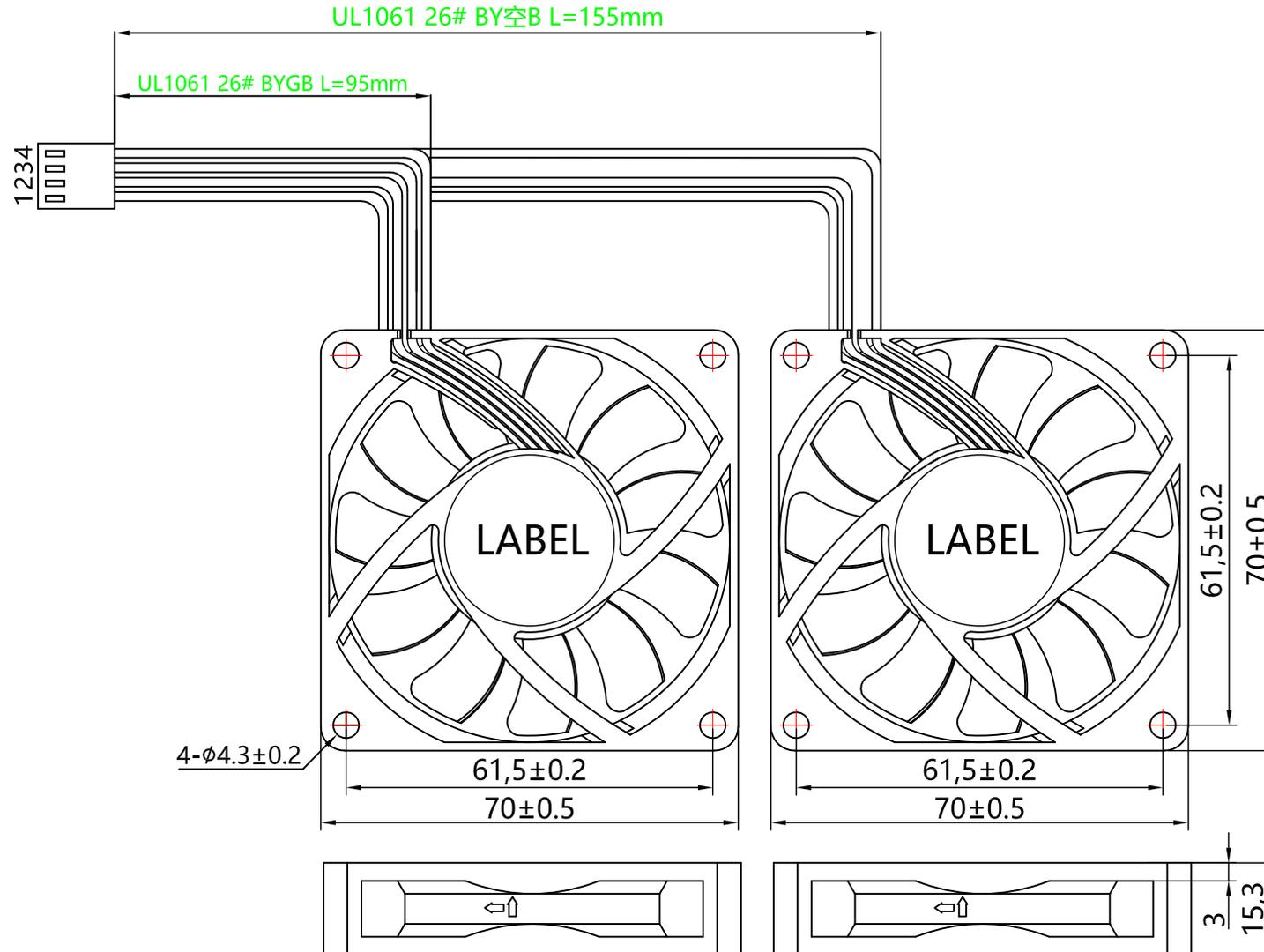

## Note:

- Lead Wire: 1061#26AWG 80°C 300V UL,CSA APPROVAL
  - PIN 1: Black Wire ----- Ground
  - PIN 2: Yellow Wire ----- Power
  - PIN 3: Green Wire-----Signal
  - PIN 4: Blue Wire-----PWM
- Connector: White of 2.54-4PIN or Equivalent



# DYNATRON CORPORATION

TOP MOTOR TECHNOLOGY (HUIZHOU) CO, LTD

## Specification for Approval

Customer:		
Model Number:	DF127015BU(70*70*15mm)	
Part Number:		
Issued Date:	Tuesday June 04, 2019	
<b>Customer Approval</b>		
Approval:	Check:	
Corporate Headquarters <b>Dynatron Corporation</b> 41458 Christy Street, Fremont, California 94538, U.S.A. Tel: 510-498-8888 Fax: 510-498-8488	Manufactory <b>TOP MOTOR TECHNOLOGY(HUIZHOU)CO,LTD</b> Baishi Village,QiuchangTown, Huiyang Dist,HuizhouCity,Guangdong Province,P.R.China Tel: 86-752-353-5555 (Rep.) Fax: 86-752-353-5592	
<i>Los Angeles Office (U.S.A.)</i> 337 Paseo Sonrisa, Walnut, California 91789 U.S.A. Tel: 909-598-2222 Fax: 909-598-8158	<i>Taipei Office (Taiwan, R.O.C.)</i> 8F, No. 35,Lane:221, Gang Cian Road, Taipei, Taiwan, R.O.C. Tel: 886-2-2799-5799(Rep.) Fax: 886-2-2799-9577	
Approval:	Check:	Initiator:
Simon Wang	-	Lin Yang



# DYNATRON CORPORATION

**TOP MOTOR TECHNOLOGY (HUIZHOU) CO, LTD**

	CONTENTS	Page
1.	SCOPE	3
2.	ELECTRICAL CHARACTERISTICS	3
3.	MECHANICAL CHARACTERISTICS	4
4.	ENVIRONMENTAL	4
5.	PROTECTION	5
6.	ATTACHMENTS	5
	6.1. Product Dimension	6
	6.2. Frequency Generator Output	7
	6.3. TUV Certificate	8
	6.4. UL Certificate	9-12
	6.5. Electrical specifications for pwm production	13-14



# DYNATRON CORPORATION

TOP MOTOR TECHNOLOGY (HUIZHOU) CO, LTD

## 1. SCOPE

This specification defines the electrical and mechanical characteristics of the □ AC / ■ DC Brush less(□Liquid State /■2-Balls Bearing )axial flow fan, which is carefully designed and manufactured for your special needs by Dynatron Corporation.

## 2. ELECTRICAL CHARACTERISTICS

Items		Description		
1.	Rated Voltage	DC 12 V		
2.	Operating Voltage	10.8 V ~ 13.2 V		
3.	PWM Frequency 25KHz	Duty Cycle D= 25%	Duty Cycle D= 50%	Duty Cycle D= 100%
4.	Start Voltage	7V		
5.	Air Flow – At rated voltage zero static pressure (minimal value)	0.777 m <sup>3</sup> /z min (27.43CFM)	1.059 m <sup>3</sup> / min (37.40CFM)	1.530m <sup>3</sup> / min (54.02CFM)
6.	Static Pressure – At rated voltage At zero air flow	2.95mm-H <sub>2</sub> O (0.116inch-H <sub>2</sub> O)	5.49mm-H <sub>2</sub> O (0.216inch-H <sub>2</sub> O)	11.45mm-H <sub>2</sub> O (0.451inch-H <sub>2</sub> O)
7.	Input Current (Max.)	0.15A	0.27A	0.66A
8.	Speed (at 25°C)	3300RPM ±10%	4500RPM ±10%	6000-6500RPM ±10%
9.	Acoustical Noise	31.70dBA	38.44dBA	46.42dBA
10.	Input Power	1.80W	3.24W	7.92W
11.	Insulation Resistance – Between Frame and Terminal	10 M ohm at DC 500 V		
12.	Dielectric Strength – Between Frame and Terminal	5 mA (Max.) @ AC 500 V 60 Hz 1 min.		
13.	Life – Continuous operating under normal temperature (40 °C or 104 °F)	70,000 hours		
14.	Rotation	Anticlockwise Air Discharged		
15.	Lead Wires	UL 1007, awg 26 or Equivalent “-“: Black; “+“: Yellow;”s“: Green. ”PWM“: Blue.		



# DYNATRON CORPORATION

TOP MOTOR TECHNOLOGY (HUIZHOU) CO, LTD

### 3. MECHANICAL CHARACTERISTICS

Items		Description
1.	Dimension	Display as Drawing
2.	Frame	PBT+30%GF UL94V-0 (Black)
3.	Impeller	PBT+30%GF UL94V-0 (Black)
4.	Bearing System	Two balls Bearing
5.	Weight	52±5grams

### 4. ENVIRONMENTAL

Items		Description
1.	Operating Temperature	- 10 °C ~ + 65 °C (65 %RH)
2.	Storage Temperature	- 30 °C ~ + 70 °C (65 %RH)
3.	Vibration Test	Motor withstands 1000 rpm vibrating with 2 mm amplitude for 30 minutes up and down, right and left, back and forth directions.
4.	Drop Test	Motor withstands one free body drop from 30 cm in high onto 10 mm thickness of wooden board for each of the three faces in minimum packing condition.
5.	Acoustic Noise	46.42dBA – Curve (Max 47.11dBA) Measuring Condition – Under rated voltage in semi-anechoic chamber equipment sound level meter. (Figure A.)

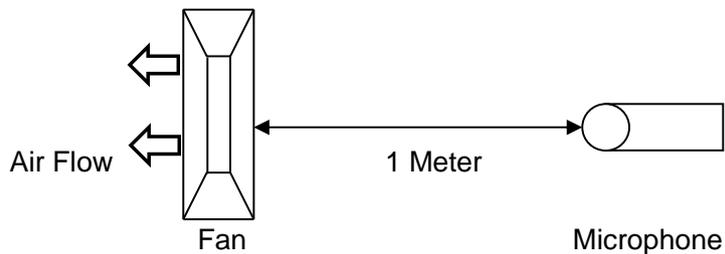

Figure A – Noise Level is measure at rated voltage in anechoic chamber in free air as above.



# DYNATRON CORPORATION

**TOP MOTOR TECHNOLOGY (HUIZHOU) CO, LTD**

## 5. PROTECTION

Items		Description
1.	Polarity Protection	For polarity error connection to power, the circuit withstands reversed connection between positive and negative leads.
2.	Locked Rotor Protection	Motor winding protects the motor from damage in 72 hours of locked rotor condition at rated voltage.

## 6. ATTACHMENTS

- 6.1. Product Dimension
- 6.2. Frequency Generator Output
- 6.3. TUV Certificate
- 6.4. UL Certificate
- 6.5. Electrical specifications for PWM production



# DYNATRON CORPORATION

TOP MOTOR TECHNOLOGY (HUIZHOU) CO, LTD

## 6.1. Product Dimension

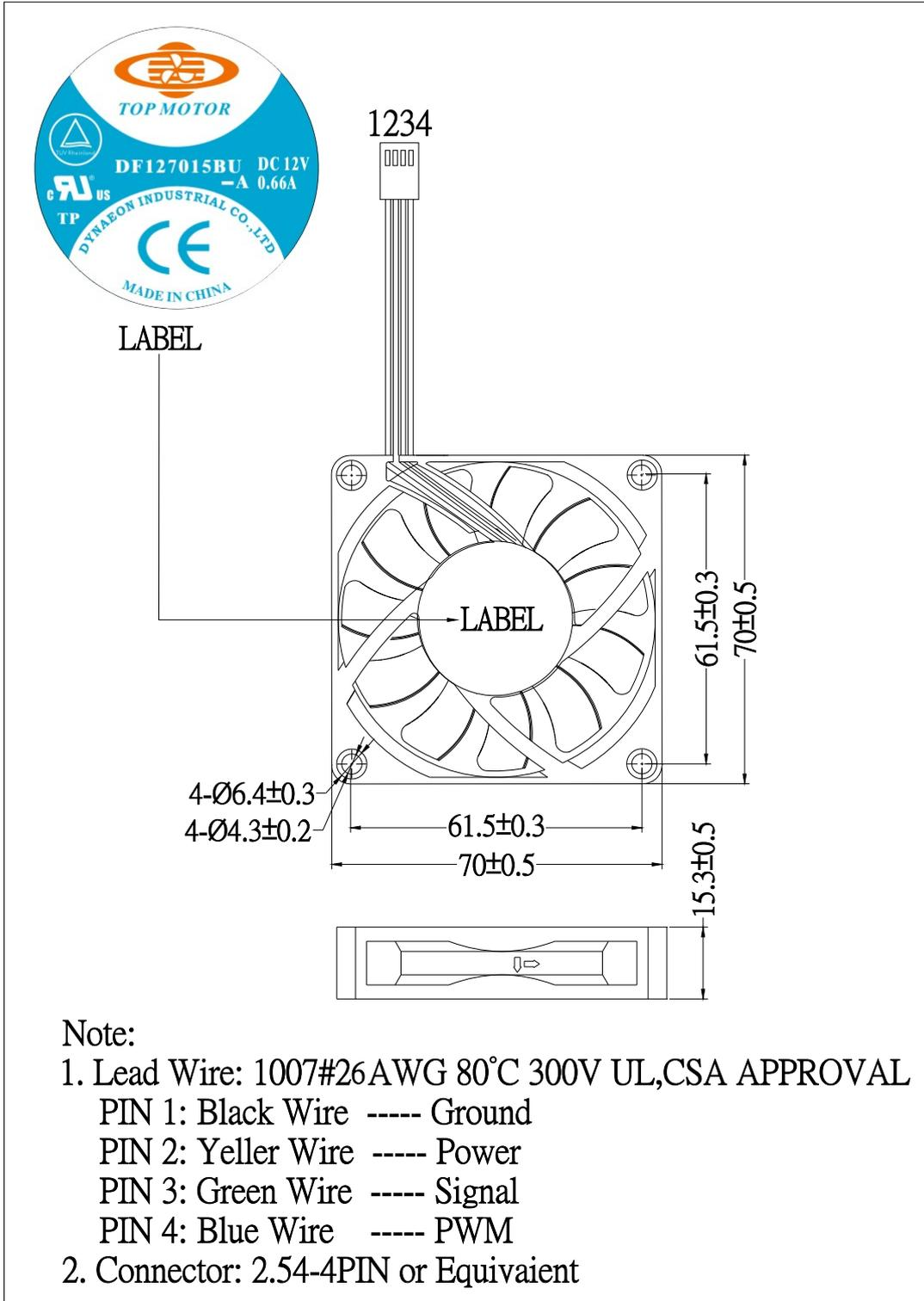



# DYNATRON CORPORATION

## TOP MOTOR TECHNOLOGY (HUIZHOU) CO, LTD

### 6.2. Frequency Generator Output

#### FREQUENCY GENERATOR O/P:

Frequency generator function is activated by an internal IC for customer's application.  
Electrical schematic:

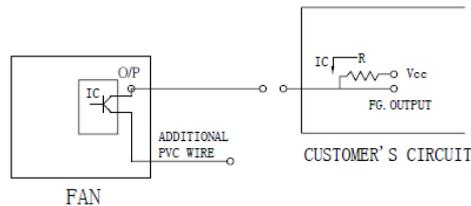

#### CUSTOMER'S CIRCUIT

$V_{cc}$  = From +5 To +28 VDC (Generally using +12 or +24 VDC)  
 $I_c$  = 5 mA max.  
 $R = V/I$  (Output "R" value calculation)

#### ● SUPPLY A WAVEFORM:

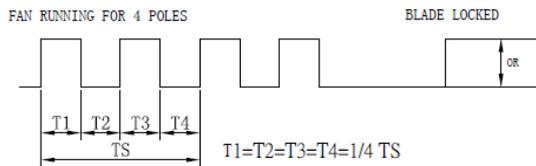

$N=R.P.M.$  (Rotation speed will be different for various models  
 L/M/H/HH/VH/SH)

$TS=60/N$  (Sec)

\* Voltage level after blade locked

#### ● OUTPUT LEVEL:

High =  $V_{cc}$  10%

Low = 0~0.5V

$I_c$  = 5 mA max.

#### ● APPLICATION:

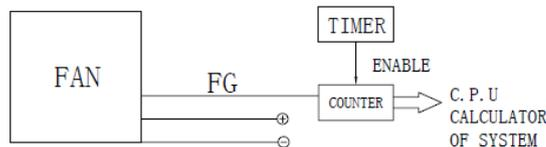

#### ● FUNCTIONS:

- By means of waveform & customer's design, schematic can reach alarm function, either in the form of buzzing or LED flashing. Adjust rotation speed.
- When power supply output voltage level decreases, it will result in the lowering of fan rotation speed. The irregular situation will be controlled by using FG. O/P through P/S circuit to increase the output voltage and result in a stable rotation speed.



# DYNATRON CORPORATION

## TOP MOTOR TECHNOLOGY (HUIZHOU) CO, LTD

### 6.3. TUV Certificate

<b>Zertifikat</b>		<b>Certificate</b>			
Zertifikat Nr. <i>Certificate No.</i> R 50064443		Blatt <i>Page</i> 0002			
Ihr Zeichen <i>Client Reference</i> PC/DTI		Unser Zeichen <i>Our Reference</i> ZTW1-TCC- 10013649 002		Ausstellungsdatum <i>Date of Issue</i> 11.11.2005 <i>(day/mo/yr)</i>	
Genehmigungsinhaber <i>License Holder</i> Dynaeon Industrial Co., Ltd. 1st Fl., No. 362, Tanan Rd. Taipei 111 Taiwan, R.O.C.			Fertigungsstätte <i>Manufacturing Plant</i> Dynaeon Ind. Co., Ltd. Ta-Li Management Zone Ching-Hsi, Dongguan P.R. China		
Prüfzeichen <i>Test Mark</i>		Geprüft nach <i>Tested acc. to</i> EN 60950-1:2001+A11			
Zertifiziertes Produkt <i>(Geräteidentifikation)</i> <b>Certified Product</b> <i>(Product Identification)</i>		Lizenzentgelte - Einheit <i>License Fee - Unit</i>			
Ventilator (DC Fan)					
wie Blatt (as page) 01					
Ergänzung (Addition)					
Bezeichnung : DP (X1) (X2) (X3) (X4) (X5) ZZZZ- (X6) (Type Designation)					
(X1) steht für (stands for) : 05, 12, 24					
(X2) steht für (stands for) : 40, 50, 60, 70, 80					
(X3) steht für (stands for) : 10, 15, 20					
(X4) steht für (stands for) : S, B, P, Q					
(X5) steht für (stands for) : U, H, M, L, E					
Z steht für (stands for) : A-Z, 0-9 oder freibleibend (or blank)					
(X6) steht für (stands for) : A, B					
Nennspannung : DC 5V (X1 = 05); DC 12V (X1 = 12) (Rated Voltage) DC 24V (X1 = 24)					
Nennstrom : siehe Aufbau-Übersicht (Rated Current) (see constructional dataform)					
ANLAGE (Appendix): 1.1					
Dem Zertifikat liegt unsere Prüf- und Zertifizierungsordnung zugrunde. Das Produkt entspricht den o.g. Anforderungen, die Herstellung wird überwacht. This certificate is based on our Testing and Certification Regulation. The product fulfills above-mentioned-requirements, the production is subject to surveillance.					
TÜV Rheinland Product Safety GmbH, Am Grauen Stein, D-51105 Köln		Zertifizierungsstelle			
Tel.:(+49/221)8 06 - 13 71 Fax:(+49/221)8 06 - 39 35 e-mail: Althoff@de.tuv.com					
		Dipl.-Ing. F. Stöckel			



# DYNATRON CORPORATION

## TOP MOTOR TECHNOLOGY (HUIZHOU) CO, LTD

### 6.4. UL Certificate



ONLINE CERTIFICATIONS DIRECTORY

#### GPWV2.E157868 Fans, Electric - Component

[Page Bottom](#)

#### Fans, Electric - Component

[See General Information for Fans, Electric - Component](#)

**DYNAEON INDUSTRIAL CO LTD**  
8TH FL 35 LANE 221 GANGCIAN RD  
NEIHU DIST  
TAIPEI, 114 TAIWAN

E157868

**DC fans**, Models D(F)1206(Z)(Y1)(X1), D(F)1207(Z)(Y1)(X1), where (F) may be F or C, (Z) may be SH, BH, BA, SM, BM, BB, SL, BL, BC, SD, BE, BF, SG, BI, BJ, SK, BN, BO, SP, BQ, BR, SS, BT, BU, SV, BW, BX, SY, BY or BZ, (Y1) may be "-", 0 through 9 or A through Z, (X1) may be 0 through 9 or A through Z.

Models DF248015(S)(X)(Y)(Z)(W), DF488015(S)(X)(Y)(Z)(W), where (S) may be S, B or P, (X) may be U, H, M or L, (Y) and (Z) may be any alphanumeric character, blank, "-" or any symbol, (W) may be seven any alphanumeric character, blank, "-" or any symbol.

Models DF121225(A)(B)(C), DF121225(A)E(C), DF241225(A)(B)(C), DF128015(A)U(C), DF128015(A)(B)(C), DF128025(A)U(C), DF128025(A)(B)(C), DF128025(A)E(C), DF248025(A)U(C), DF248025(A)(B)(C), DF129225(A)(B)(C), DF129225(A)E(C), DF249225(A)U(C), DF249225(A)(B)(C), DF126010(A)(B)(C), DF126010(A)(B)(C), DF246025(A)U(C), DF246025(A)(B)(C), DF126025(A)U(C), DF126025(A)(B)(C), DF126025(A)E(C), DB126015BU(C), DB126015B(B)(C), DF123010(A)(B)(C), DF053010(A)(B)(C), DF127015(A)U(C), DF127015(A)(B)(C), DF245010(A)(B)(C), where (A) may be S, B, P or Q, (B) may be H, M or L, (C) may be xxxxxxxx, where x may be A through Z, 0 through 9, "-" or blank.

Models DF122510(X)(Y2)(Z)-(M), DF124020(X)(Y2)(Z)-(M), DF244020(X)(Y1)(Z)-(M), DF126025(X)(Y3)(Z)-(M), DF246025(X)(Y3)(Z)-(M), DF121225(X)(Y1)(Z)-(M), DF124028(X)(Y3)(Z)-(M), where (X) may be S, B, P, Q, (Y1) may be H, M or L, (Y2) may be U, H, M or L, (Y3) may be U, H, M, L or E, (Z) is alphanumeric combination of five digits and/or alphabets, may be A through Z, 0 through 9 or blank, (M) may be A or B.

Models DF054010(X)(Y2)(Z1)(Z2)-A, DF054010(X)L(Z1)(Z2)-B, DF124010(X)(Y2)(Z1)(Z2)-A, DF124010(X)L(Z1)(Z2)-B, DF244010(X)(Y2)(Z1)(Z2)-A, DF125015(X)(Y1)(Z1)(Z2)-A, DF125020(X)(Y3)(Z1)(Z2)-A, DF126015(X)(Y1)(Z1)(Z2)-A, DF246015(X)M(Z1)(Z2)-A, DF246015(X)L(Z1)(Z2)-A, DF128020(X)(Y1)(Z1)(Z2)-A, DF128020(X)L(Z1)(Z2)-B, DB127015(X)(Y2)(Z)-A series, where (X) may be S, B, P, Q, (Y1) may be H, M or L, (Y2) may be U, H, M or L, (Y3) may be H, M, L or E, (Z1) may be blank or 3, (Z2) is alphanumeric combination of four digits and/or alphabets, may be A through Z, 0 through 9 or blank, (Z) is alphanumeric combination of five digits and/or alphabets, may be A through Z, 0 through 9 or blank.

Models DF125010(X)(Y)(Z)-A, DF126020(X)(Y)(Z)-A, DF246020(X)(Y)(Z)-A, DF121525(X)(Y1)(Z)-A, DF121525(X)(Y2)(Z)-B series, Where (X) may be S, B, P or Q, (Y) may be H, M or L, (Y1) may be U, H or M, (Y2) may be L or E, (Z) is alphanumeric combination of five digits and/or alphabets, may be A through Z, 0 through 9 or blank.

Models DF128025(X)(a)(Y)-A, DF121225(X)(b)(Y)-C, DF121225(X)E(Y)-C, DF127720(X)(a)(Y)-A, DF121425(X)(c)(Y)-A, DF126010(X)E(Y)-A series, where (X) may be S, B, P, Q, (a) may be H, M, L or E, (b) may be M or L, (c) may be U, H, M, L or E, (Y) is alphanumeric combination of five digits and/or alphabets, may be A through Z, 0 through 9 or blank.

Models DF054010(X)(Y1)(Z1)(Z2)-C, DF124010(X)(Y2)(Z1)(Z2)-C, DF244010(X)(Y2)(Z1)(Z2)-C, DF124020BU(Z1)(Z2)-C, DF124020(X)(Y1)(Z1)(Z2)-C, DF124028BU(Z1)(Z2)-C, DF124028(X)(Y1)(Z1)(Z2)-C, DF126025BU(Z1)(Z2)-C, DF126025(X)(Y1)(Z1)(Z2)-C, DF127015BU(Z1)(Z2)-A, DF127015(X)(Y1)(Z1)(Z2)-A, DF128025BU(Z1)(Z2)-B, DF128025(X)(Y1)(Z1)(Z2)-B, DF129225BU(Z1)(Z2)-A, DF129225(X)(Y1)(Z1)(Z2)-A, DF121225BU(Z1)(Z2)-D, DF121225(X)(Y1)(Z1)(Z2)-D, DF121425(X)(Y1)(Z1)(Z2)-B, DB127015BU(Z1)(Z2)-B, DB127015(X)(Y1)(Z1)(Z2)-B, DB058015(X)(Y3)(Z1)(Z2)-A, where (X) may be S, B, P or Q, where (Y1) may be H, M, L or E, where (Y2) may be U, H, M, L or E, where (Y3) may be M or L, where (Z1) may be blank or 3, where (Z2) may be alphanumeric combination of four digits and/or alphabets, may be A through Z, 0 through 9 or blank.

Models DB128015(X)(Y1)-(Z)-A, DF128038(X)(Y1)-(Z)-A, DB121225(X)(Y2)-(Z)-A, DF054010(X)(Y2)-(Z)-D, DF124010(X)(Y3)-(Z)-D, DF244010(X)(Y4)-(Z)-D, DF125010(X)(Y2)-(Z)-B, DF126010(X)(Y5)-(Z)-B series, where (X) may be S, B, P, Q, (Y1) may be U, H, M, L or E, (Y2) may be H, M or L, (Y3) may be U, M, L or E, (Y4) may be U, H, M or L, (Y5) may be H, M, L or E, (Z) is alphanumeric combination of five digits and/or alphabets, may be A through Z, 0 through 9 or blank.

**Electric fans**, Models DC0504, -1204, -1205, -1206, DF1204, -1208, -2408, -0504, -0505, -1205, -2406 followed by "S" or



# DYNATRON CORPORATION

## TOP MOTOR TECHNOLOGY (HUIZHOU) CO, LTD

"B", followed by two alphanumeric characters.

**Low voltage fans**, Models DB1206, DF1209, -1212, -2409, DH1204 followed by B or S, followed by two alphanumeric characters.



Marking: Company name or trademark *TOP MOTOR*, model designation and Recognized Component Mark for Canada,



Last Updated on 2008-02-18

---

[Questions?](#)

[Notice of Disclaimer](#)

[Page Top](#)

[Copyright © 2009 Underwriters Laboratories Inc.®](#)

The appearance of a company's name or product in this database does not in itself assure that products so identified have been manufactured under UL's Follow-Up Service. Only those products bearing the UL Mark should be considered to be Listed and covered under UL's Follow-Up Service. Always look for the Mark on the product.

UL permits the reproduction of the material contained in the Online Certification Directory subject to the following conditions: 1. The Guide Information, Designs and/or Listings (files) must be presented in their entirety and in a non-misleading manner, without any manipulation of the data (or drawings). 2. The statement "Reprinted from the Online Certifications Directory with permission from Underwriters Laboratories Inc." must appear adjacent to the extracted material. In addition, the reprinted material must include a copyright notice in the following format: "Copyright © 2009 Underwriters Laboratories Inc.®"

*An independent organization working for a safer world with integrity, precision and knowledge.*





# DYNATRON CORPORATION

## TOP MOTOR TECHNOLOGY (HUIZHOU) CO, LTD



ONLINE CERTIFICATIONS DIRECTORY

**GPWV8.E157868**

**Fans, Electric Certified for Canada - Component**

[Page Bottom](#)

**Fans, Electric Certified for Canada - Component**

[See General Information for Fans, Electric Certified for Canada - Component](#)

**DYNAEON INDUSTRIAL CO LTD**  
8TH FL 35 LANE 221 GANGCIAN RD  
NEIHU DIST  
TAIPEI, 114 TAIWAN

E157868

**DC fans**, Models D(F)1206(Z)(Y1)(X1), D(F)1207(Z)(Y1)(X1), where (F) may be F or C, (Z) may be SH, BH, BA, SM, BM, BB, SL, BL, BC, SD, BE, BF, SG, BI, BJ, SK, BN, BO, SP, BQ, BR, SS, BT, BU, SV, BW, BX, SY, BY or BZ, (Y1) may be "-", 0 through 9 or A through Z, (X1) may be 0 through 9 or A through Z.

Models DF248015(S)(X)(Y)(Z)(W), DF488015(S)(X)(Y)(Z)(W), where (S) may be S, B or P, (X) may be U, H, M or L, (Y) and (Z) may be any alphanumeric character, blank, "-" or any symbol, (W) may be seven any alphanumeric character, blank, "-" or any symbol.

Models DF121225(A)(B)(C), DF121225(A)E(C), DF241225(A)(B)(C), DF128015(A)U(C), DF128015(A)(B)(C), DF128025(A)U(C), DF128025(A)(B)(C), DF128025(A)E(C), DF248025(A)U(C), DF248025(A)(B)(C), DF129225(A)(B)(C), DF129225(A)E(C), DF249225(A)U(C), DF249225(A)(B)(C), DF126010(A)(B)(C), DF246025(A)U(C), DF246025(A)(B)(C), DF126025(A)(B)(C), DF126025(A)E(C), DB126015BU(C), DB126015B(B)(C), DF123010(A)(B)(C), DF053010(A)(B)(C), DF127015(A)U(C), DF127015(A)(B)(C), DF245010(A)(B)(C), where (A) may be S, B, P or Q, (B) may be H, M or L, (C) may be xxxxxxxx, where x may be A through Z, 0 through 9, "-" or blank.

Models DF122510(X)(Y2)(Z)-(M), DF124020(X)(Y2)(Z)-(M), DF244020(X)(Y1)(Z)-(M), DF126025(X)(Y3)(Z)-(M), DF246025(X)(Y3)(Z)-(M), DF121225(X)(Y1)(Z)-(M), DF124028(X)(Y3)(Z)-(M), where (X) may be S, B, P, Q, (Y1) may be H, M or L, (Y2) may be U, H, M or L, (Y3) may be U, H, M, L or E, (Z) is alphanumeric combination of five digits and/or alphabets, may be A through Z, 0 through 9 or blank, (M) may be A or B.

Models DF054010(X)(Y2)(Z1)(Z2)-A, DF054010(X)L(Z1)(Z2)-B, DF124010(X)(Y2)(Z1)(Z2)-A, DF124010(X)L(Z1)(Z2)-B, DF244010(X)(Y2)(Z1)(Z2)-A, DF125015(X)(Y1)(Z1)(Z2)-A, DF125020(X)(Y3)(Z1)(Z2)-A, DF126015(X)(Y1)(Z1)(Z2)-A, DF246015(X)M(Z1)(Z2)-A, DF246015(X)L(Z1)(Z2)-A, DF128020(X)(Y1)(Z1)(Z2)-A, DF128020(X)L(Z1)(Z2)-B, DB127015(X)(Y2)(Z)-A series, where (X) may be S, B, P, Q, (Y1) may be H, M or L, (Y2) may be U, H, M or L, (Y3) may be H, M, L or E, (Z1) may be blank or 3, (Z2) is alphanumeric combination of four digits and/or alphabets, may be A through Z, 0 through 9 or blank, (Z) is alphanumeric combination of five digits and/or alphabets, may be A through Z, 0 through 9 or blank.

Models DF125010(X)(Y)(Z)-A, DF126020(X)(Y)(Z)-A, DF246020(X)(Y)(Z)-A, DF121525(X)(Y1)(Z)-A, DF121525(X)(Y2)(Z)-B series, Where (X) may be S, B, P or Q, (Y) may be H, M or L, (Y1) may be U, H or M, (Y2) may be L or E, (Z) is alphanumeric combination of five digits and/or alphabets, may be A through Z, 0 through 9 or blank.

Models DF128025(X)(a)(Y)-A, DF121225(X)(b)(Y)-C, DF121225(X)E(Y)-C, DF127720(X)(a)(Y)-A, DF121425(X)(c)(Y)-A, DF126010(X)E(Y)-A series, where (X) may be S, B, P, Q, (a) may be H, M, L or E, (b) may be M or L, (c) may be U, H, M, L or E, (Y) is alphanumeric combination of five digits and/or alphabets, may be A through Z, 0 through 9 or blank.

Models DF054010(X)(Y1)(Z1)(Z2)-C, DF124010(X)(Y2)(Z1)(Z2)-C, DF244010(X)(Y2)(Z1)(Z2)-C, DF124020BU(Z1)(Z2)-C, DF124020(X)(Y1)(Z1)(Z2)-C, DF124028BU(Z1)(Z2)-C, DF124028(X)(Y1)(Z1)(Z2)-C, DF126025BU(Z1)(Z2)-C, DF126025(X)(Y1)(Z1)(Z2)-C, DF127015BU(Z1)(Z2)-A, DF127015(X)(Y1)(Z1)(Z2)-A, DF128025BU(Z1)(Z2)-B, DF128025(X)(Y1)(Z1)(Z2)-B, DF129225BU(Z1)(Z2)-A, DF129225(X)(Y1)(Z1)(Z2)-A, DF121225BU(Z1)(Z2)-D, DF121225(X)(Y1)(Z1)(Z2)-D, DF121425(X)(Y1)(Z1)(Z2)-B, DB127015BU(Z1)(Z2)-B, DB127015(X)(Y1)(Z1)(Z2)-B, DB058015(X)(Y3)(Z1)(Z2)-A, where (X) may be S, B, P or Q, where (Y1) may be H, M, L or E, where (Y2) may be U, H, M, L or E, where (Y3) may be M or L, where (Z1) may be blank or 3, where (Z2) may be alphanumeric combination of four digits and/or alphabets, may be A through Z, 0 through 9 or blank.

Models DB128015(X)(Y1)-(Z)-A, DF128038(X)(Y1)-(Z)-A, DB121225(X)(Y2)-(Z)-A, DF054010(X)(Y2)-(Z)-D, DF124010(X)(Y3)-(Z)-D, DF244010(X)(Y4)-(Z)-D, DF125010(X)(Y2)-(Z)-B, DF126010(X)(Y5)-(Z)-B series, where (X) may be S, B, P, Q, (Y1) may be U, H, M, L or E, (Y2) may be H, M or L, (Y3) may be U, M, L or E, (Y4) may be U, H, M or L, (Y5) may be H, M, L or E, (Z) is alphanumeric combination of five digits and/or alphabets, may be A through Z, 0 through 9 or blank.

**Electric fans**, Models DC0504, -1204, -1205, -1206, DF0504, -0505, -1204, -1205, -1208, -2406, -2408 followed by "S" or



# DYNATRON CORPORATION

## TOP MOTOR TECHNOLOGY (HUIZHOU) CO, LTD

"B", followed by two alphanumeric characters.

**Low voltage fans**, Models DB1206, DF1209, -1212, -2409, DH1204 followed by B or S, followed by two alphanumeric characters.



Marking: Company name or trademark **TOP MOTOR**, model designation and Recognized Component Mark for Canada,



Last Updated on 2008-02-18

---

[Questions?](#)

[Notice of Disclaimer](#)

[Page Top](#)

[Copyright © 2009 Underwriters Laboratories Inc.®](#)

The appearance of a company's name or product in this database does not in itself assure that products so identified have been manufactured under UL's Follow-Up Service. Only those products bearing the UL Mark should be considered to be Listed and covered under UL's Follow-Up Service. Always look for the Mark on the product.

UL permits the reproduction of the material contained in the Online Certification Directory subject to the following conditions: 1. The Guide Information, Designs and/or Listings (files) must be presented in their entirety and in a non-misleading manner, without any manipulation of the data (or drawings). 2. The statement "Reprinted from the Online Certifications Directory with permission from Underwriters Laboratories Inc." must appear adjacent to the extracted material. In addition, the reprinted material must include a copyright notice in the following format: "Copyright © 2009 Underwriters Laboratories Inc.®"

*An independent organization working for a safer world with integrity, precision and knowledge.*





# DYNATRON CORPORATION

## TOP MOTOR TECHNOLOGY (HUIZHOU) CO, LTD

### 6.5. Electrical Specifications for pwm production

USA Dynatron Corp.

#### Electrical Specifications for PWM production

##### Voltage

Fan operating voltage shall be within the range 12V $\pm$ 1.2V.

##### Current

Peak fan current draw during start-up operation(with 13.2V applied,with fan operating in the free stream condition)shall not exceed 2.0 A.

Fan current spike during start-up operation(with 13.2V applied with fan operating in the free stream condition)shall be allowed to exceed 1.0 A for a duration of no greater than 1.0 sec.

##### Tachometer Output Signal

Fan shall provide tachometer output signal with the following characteristics:

- \* Two pulses per revolution
- \* Open-collector or open-drain type output
- \* Motherboard will have a pull up to 12V, maximum 13.2V

##### PWM Control Input Signal

The following requirements are measured at the PWM(control) pin of the fan cable

connector:PWM Frequency:Target frequency 25kHz,

acceptable operational range 21 kHz to 28 KHz

Maximum voltage for logic low:VIL=0.8V

Absolute maximum current sourced:Imax=5mA(short circuit current)

Absolute maximum voltage level:Vmax=5.25V(open circuit voltage)

##### Fan Speed Control

###### 1.1 Maximum Fan Speed Requirements

The maximum fan speed shall be specified for the fan model by the vendor and correspond to 100% duty cycle PWM signal input.

###### 1.2 Minimum Fan Speed Requirements

The vendor shall specify the minimum RPM and the corresponding PWM duty cycle. This specified minimum RPM shall be 30% of maximum RPM or less. The fan shall be able to start and run at this RPM. To allow a lower specified minimum RPM, it is acceptable to provide a higher PWM duty cycle to the fan motor for a short period of time for startup conditions. This pulse should not exceed 30% maximum RPM and should last no longer than 2 seconds.



# DYNATRON CORPORATION

## TOP MOTOR TECHNOLOGY (HUIZHOU) CO, LTD

USA Dynatron Corp.

### 1.3 Fan Speed Response PWM Control Input Signal

The PWM input shall be delivered to the fan through the control signal on Pin4. Fan speed response to this signal shall be a continuous and monotonic of the duty cycle of the signal, from 100% to the minimum specified RPM. The fan RPM (as a percentage of maximum RPM) should match the PWM duty cycle within  $\pm 10\%$ . If no control signal is present the fan shall operate at maximum RPM.

Figure 1 Fan speed Response to PWM Control input Signal

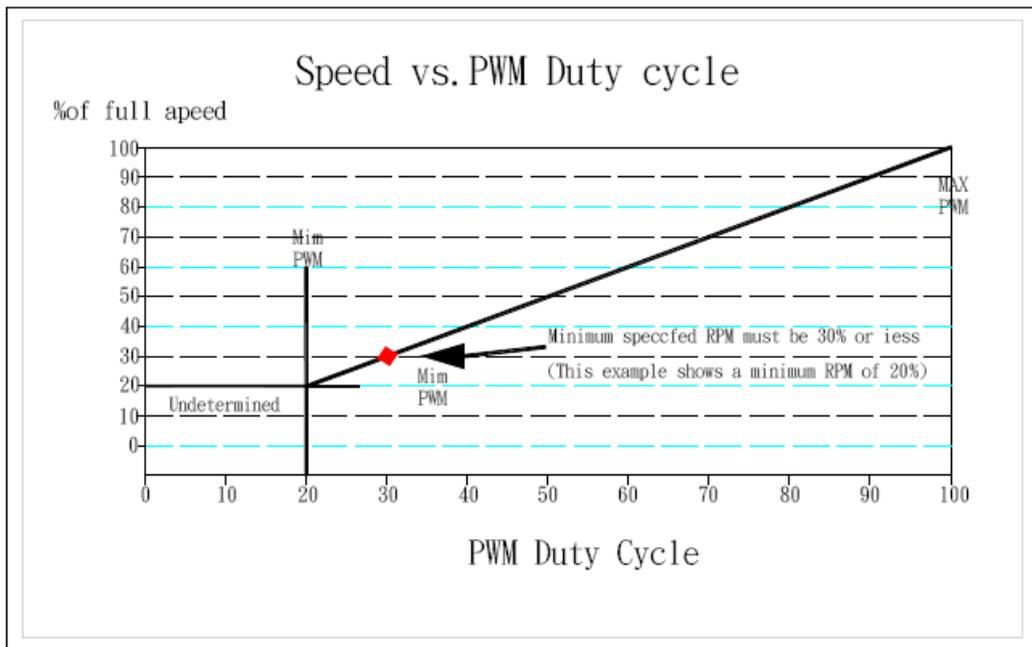

### 1.4 Operation Below Minimum RPM

For all duty cycles less than the minimum duty cycle, the RPM shall not be greater than the minimum RPM. The following graphs and definitions show three recommended solutions to handle PWM duty cycles that are less than the minimum operational PWM, as a percentage of maximum.

Reference resource by Intel's 4-wire PWM Fan controlled specification.