



# A3

1U Active Air Cooler

**PRODUCT SPECIFICATIONS**



## **NEW PRODUCT SPEC SHEET**

### **Model Number: A3**

- Recommend for AMD® G34 Processor, Socket 1974
- Active Cooler for 1U Server

### **Overall Specification:**

- Dimension: 115.0 x 75.0 x 27.5 mm
- Weight: 425 +/- 5g
- Mounting Pitch 4.1" (104.1 mm)
- Material: Copper 1100 with Skiving Fins
- 7015 Aluminum Frame Cooling Blower
- Captive with Screw-on Mounting
- Thermal Grease Pre-printed with Shin Etsu 7762
- Support CPU Power up to 115 Watts

### **Fan Specification:**

- Dimension: 70.0 x 70.0 x 15.0 mm
- Rated Speed: 6000 ± 5% RPM
- Bearing: 2 x Ball
- Rated Voltage: DC12V
- Maximum Airflow: 12.83 CFM
- Acoustical Noise: 54.4 dBA
- Lead Wire Pin Out: Pin#1 - Black (-)  
Pin#2 - Red (+)  
Pin#3 – White (Tachometer / Signal Output)

**CONFIDENTIAL DOCUMENT**

THIS DRAWING CONTAINS INFORMATION PROPRIETARY TO DYNATRON CORPORATION AND DYNAEON INDUSTRIAL CO., LTD. ANY REPRODUCTION, DISCLOSURE, OR USE OF THIS DRAWING IS EXPRESSLY PROHIBITED EXCEPT AS DYNATRON CORPORATION AND DYNAEON INDUSTRIAL CO., LTD. MAY OTHERWISE AGREE TO IN WRITING.

**ASSEMBLY PARTS**

ITEM#	DESCRIPTION	CHECKER	DATE
01	INITIAL RELEASE	LANG	02/17/2010

**WHOLE SET OF COOLER**

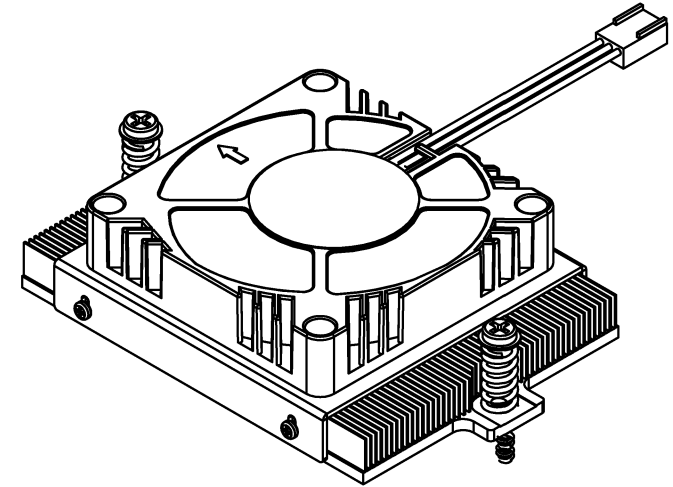
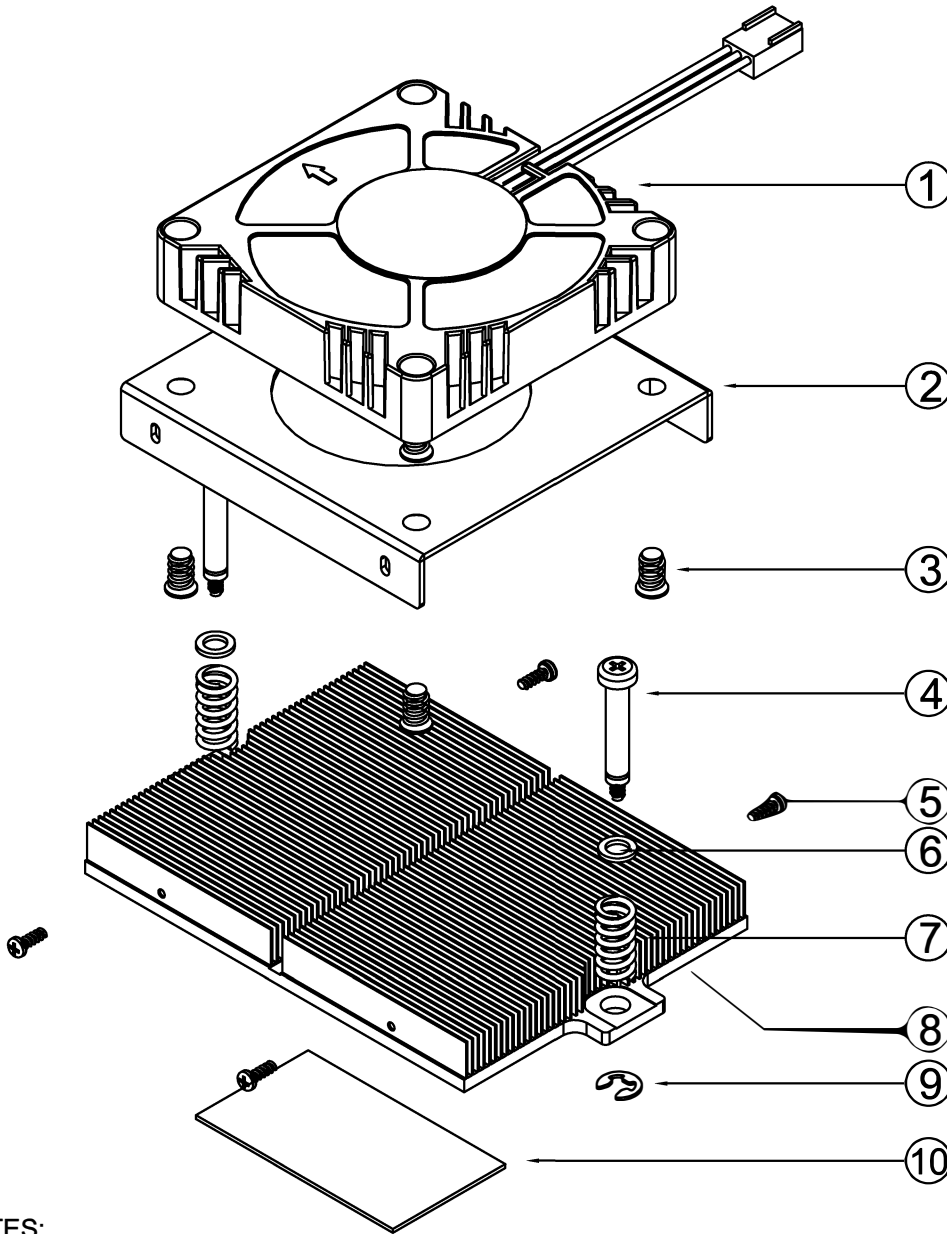

**NOTES:**

1. THE FIGURE IS FOR REFERENCE ONLY, AND NOT FOR SCALE
2. OVERALL DIMENSION : 115.0 x 74.5 x 27.5 mm
3. OVERALL WEIGHT : 425 g

10	Thermal Grease, Pre-Print	TIG830SP	1
9	E-Clip	Steel	2
8	Heatsink	Copper 1100	1
7	Spring, Ø1.4mm Wire	Plastic	2
6	Washer	Steel	2
5	Screw, Cover to Heatsink	Steel	4
4	Screw, Heatsink Mounting	Steel	2
3	Screw, Blower to Cover	Steel	4
2	Cover, Blower	Aluminum	1
1	Blower, DB127015BU-3P	Aluminum	1

Item#	Description	Material	QTY.
DATE		NAME	
02/17/2010		Engr	
CHECKED		TITLE:	
02/17/2010		LANG	
ENGL APPR.		<b>1U Active Cooler A3</b> BOM & Exploded Assembly Drawing	
MFG APPR.			
QA			
COMMENTS		DWG. No:	REV
		DYN-EP-A3	00

ITEM#	DESCRIPTION	CHECKER	DATE
1	Initial Release	LANG	02/17/10

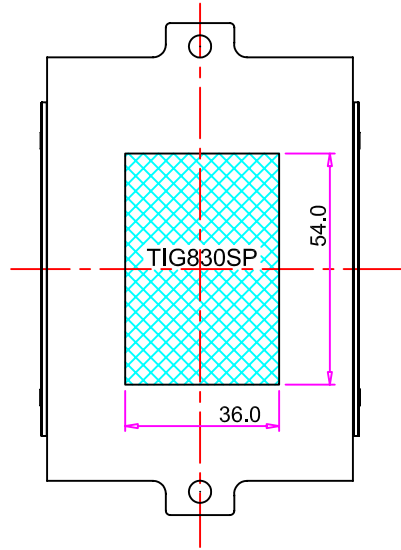
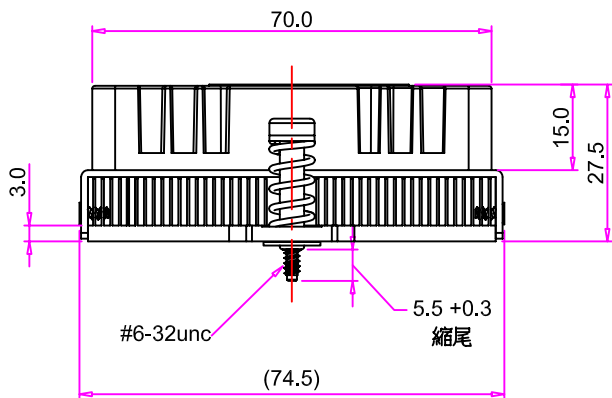
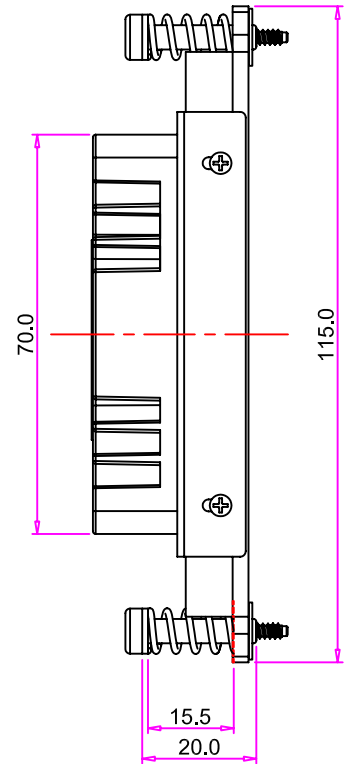
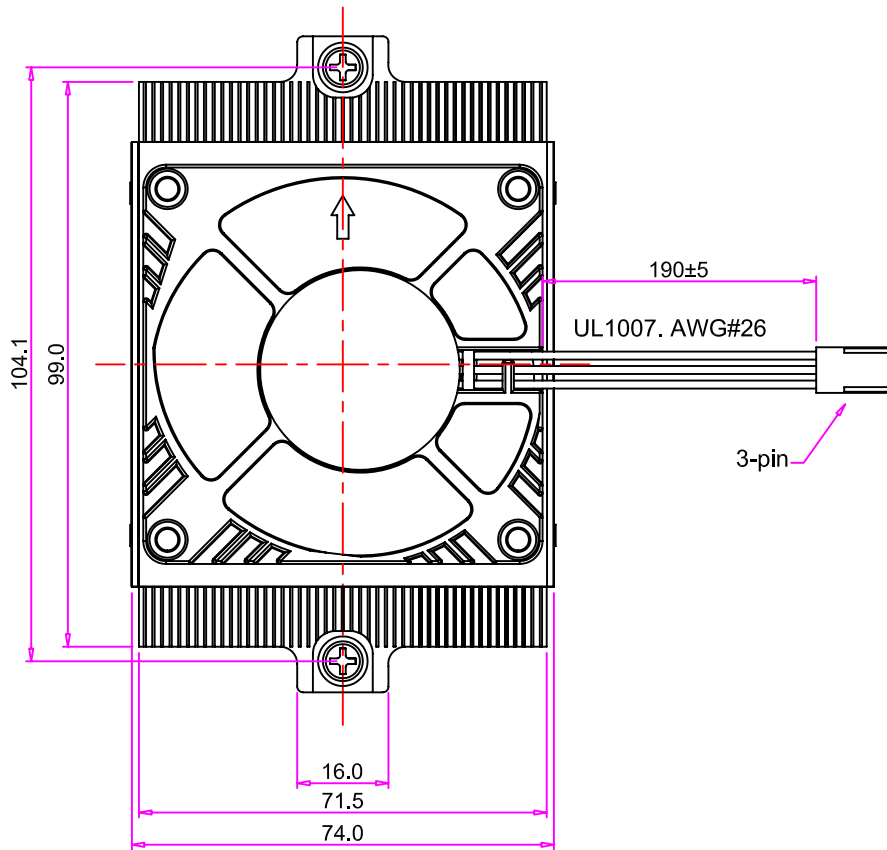

Bottom Surface  
Thermal Grease Pre-Print Zone  
Scale 3/4 : 1

	NAME	DATE
DRAWN BY	Engr.	02/17/2010
CHECKED BY	LANG	02/17/2010
ENG. APPROVED		
MFG. APPROVED	-	-



DYNATRON CORPORATION

TITLE: **1U Passive Heatsink A3**  
**Overall Dimension Drawing**

**CONFIDENTIAL DOCUMENT**

THIS DRAWING CONTAINS INFORMATION PROPRIETARY TO DYNATRON CORPORATION AND DYNAEON INDUSTRIAL CO., LTD. ANY REPRODUCTION, DISCLOSURE, OR USE OF THIS DRAWING IS EXPRESSLY PROHIBITED EXCEPT AS DYNATRON CORPORATION AND DYNAEON INDUSTRIAL CO., LTD. MAY OTHERWISE AGREE TO IN WRITING.

VIEW	
UNITS	MM

DWG. No:

**DYN-DM-A3**

REV. **00**