

EMX-WHLGP

8th Gen Intel® Whiskey Lake U Core™ SoC i7/i5/i3 &
Celeron® BGA Onboard Processor Thin MINI ITX
motherboard

User's Manual



5th Ed – 04 June 2021

FCC Statement



THIS DEVICE COMPLIES WITH PART 15 FCC RULES. OPERATION IS SUBJECT TO THE FOLLOWING TWO CONDITIONS:

- (1) THIS DEVICE MAY NOT CAUSE HARMFUL INTERFERENCE.
- (2) THIS DEVICE MUST ACCEPT ANY INTERFERENCE RECEIVED INCLUDING INTERFERENCE THAT MAY CAUSE UNDESIRE OPERATION.

THIS EQUIPMENT HAS BEEN TESTED AND FOUND TO COMPLY WITH THE LIMITS FOR A CLASS "A" DIGITAL DEVICE, PURSUANT TO PART 15 OF THE FCC RULES.

THESE LIMITS ARE DESIGNED TO PROVIDE REASONABLE PROTECTION AGAINST HARMFUL INTERFERENCE WHEN THE EQUIPMENT IS OPERATED IN A COMMERCIAL ENVIRONMENT. THIS EQUIPMENT GENERATES, USES, AND CAN RADIATE RADIO FREQUENCY ENERGY AND, IF NOT INSTALLED AND USED IN ACCORDANCE WITH THE INSTRUCTION MANUAL, MAY CAUSE HARMFUL INTERFERENCE TO RADIO COMMUNICATIONS.

OPERATION OF THIS EQUIPMENT IN A RESIDENTIAL AREA IS LIKELY TO CAUSE HARMFUL INTERFERENCE IN WHICH CASE THE USER WILL BE REQUIRED TO CORRECT THE INTERFERENCE AT HIS OWN EXPENSE.

Notice

This guide is designed for experienced users to setup the system within the shortest time. For detailed information, please always refer to the electronic user's manual.

Copyright Notice

Copyright © 2021 Avalue Technology Inc., ALL RIGHTS RESERVED.

No part of this document may be reproduced, copied, translated, or transmitted in any form or by any means, electronic or mechanical, for any purpose, without the prior written permission of the original manufacturer.

Trademark Acknowledgement

Brand and product names are trademarks or registered trademarks of their respective owners.

Disclaimer

Avalue Technology Inc. reserves the right to make changes, without notice, to any product, including circuits and/or software described or contained in this manual in order to improve design and/or performance. Avalue Technology assumes no responsibility or liability for the use of the described product(s), conveys no license or title under any patent, copyright, or masks work rights to these products, and makes no representations or warranties that

these products are free from patent, copyright, or mask work right infringement, unless otherwise specified. Applications that are described in this manual are for illustration purposes only. Avalue Technology Inc. makes no representation or warranty that such application will be suitable for the specified use without further testing or modification.

Life Support Policy

Avalue Technology's PRODUCTS ARE NOT FOR USE AS CRITICAL COMPONENTS IN LIFE SUPPORT DEVICES OR SYSTEMS WITHOUT THE PRIOR WRITTEN APPROVAL OF Avalue Technology Inc.

As used herein:

1. Life support devices or systems are devices or systems which, (a) are intended for surgical implant into body, or (b) support or sustain life and whose failure to perform, when properly used in accordance with instructions for use provided in the labeling, can be reasonably expected to result in significant injury to the user.
2. A critical component is any component of a life support device or system whose failure to perform can be reasonably expected to cause the failure of the life support device or system, or to affect its safety or effectiveness.

A Message to the Customer

Avalue Customer Services

Each and every Avalue's product is built to the most exacting specifications to ensure reliable performance in the harsh and demanding conditions typical of industrial environments. Whether your new Avalue device is destined for the laboratory or the factory floor, you can be assured that your product will provide the reliability and ease of operation for which the name Avalue has come to be known.

Your satisfaction is our primary concern. Here is a guide to Avalue's customer services. To ensure you get the full benefit of our services, please follow the instructions below carefully.

Technical Support

We want you to get the maximum performance from your products. So if you run into technical difficulties, we are here to help. For the most frequently asked questions, you can easily find answers in your product documentation. These answers are normally a lot more detailed than the ones we can give over the phone. So please consult the user's manual first.

To receive the latest version of the user's manual; please visit our Web site at:

<http://www.avalue.com.tw/>

EMX-WHLGP User's Manual

Product Warranty

Avalue warrants to you, the original purchaser, that each of its products will be free from defects in materials and workmanship for two years from the date of purchase.

This warranty does not apply to any products which have been repaired or altered by persons other than repair personnel authorized by Avalue, or which have been subject to misuse, abuse, accident or improper installation. Avalue assumes no liability under the terms of this warranty as a consequence of such events. Because of Avalue's high quality-control standards and rigorous testing, most of our customers never need to use our repair service. If any of Avalue's products is defective, it will be repaired or replaced at no charge during the warranty period. For out-of-warranty repairs, you will be billed according to the cost of replacement materials, service time, and freight. Please consult your dealer for more details. If you think you have a defective product, follow these steps:

1. Collect all the information about the problem encountered. (For example, CPU type and speed, Avalue's products model name, hardware & BIOS revision number, other hardware and software used, etc.) Note anything abnormal and list any on-screen messages you get when the problem occurs.
2. Call your dealer and describe the problem. Please have your manual, product, and any helpful information available.
3. If your product is diagnosed as defective, obtain an RMA (return material authorization) number from your dealer. This allows us to process your good return more quickly.
4. Carefully pack the defective product, a complete Repair and Replacement Order Card and a photocopy proof of purchase date (such as your sales receipt) in a shippable container. A product returned without proof of the purchase date is not eligible for warranty service.
5. Write the RMA number visibly on the outside of the package and ship it prepaid to your dealer.

Content

1. Getting Started	8
1.1 Safety Precautions	8
1.2 Packing List	8
1.3 Order information	9
1.4 Document Amendment History	9
1.5 Manual Objectives	10
1.6 System Specifications	11
1.7 Architecture Overview—Block Diagram	15
1.8 Expansion design	16
2. Hardware Configuration	17
2.1 Product Overview	18
2.2 Jumper and Connector List	19
2.3 Setting Jumpers & Connectors	21
2.3.1 Serial port 1/2 pin9 signal select (JCOM1-RI-RS485)	21
2.3.2 Serial port 1/2 pin9 signal select (JCOM2-RI-RS486)	21
2.3.3 LVDS Back Light power selection (JSBKL1)	22
2.3.4 AT/ATX Power Mode Select (JSATX1)	22
2.3.5 Clear CMOS (JCMOS1)	23
2.3.6 LCD Inverter connector (JBKL1)	23
2.3.7 Serial port 1 connector (COM1)	24
2.3.8 Serial port 2 connector (COM2)	24
2.3.9 General purpose I/O connector (DIO1)	25
2.3.10 SPI connector (JSPI1)	25
2.3.11 Serial port 3-6 connector (COM3-6)	26
2.3.12 SATA Power connector (SPWR1)	27
2.3.13 CPU Fan connector (JFAN1)	27
2.3.14 USB connector 1(USB1)	28
2.3.15 USB connector 2(USB2)	28
2.3.16 LVDS connector (LVDS1)	29
2.3.17 Front Audio connector (FAUD1)	30
2.3.18 EC Debug (JEC_DEBUG)	30
2.3.19 Battery connector (BAT1)	31
2.3.20 PS/2 keyboard & mouse header (KB/MS)	31
2.3.21 Miscellaneous setting connector 1 (FPT1)	32
2.3.22 Miscellaneous setting connector 2 (FPT2)	32
2.3.23 LED indicator connector 1 (LED1)	33
2.3.24 LED indicator connector 2 (LED2)	33

EMX-WHLGP User's Manual

2.3.25	LED indicator connector 3 (LED3)	34
2.3.26	Speaker connector (SPK1)	34
2.3.27	JI2C connector (JI2C1)	35
2.3.28	LPC connector (JLPC1)	35
2.3.29	CPU Heatsink Heater Connector (JHT1/2/3/4/5/6)	36
2.3.30	LED Indicator for Heater (JHT_LED1)	36
2.3.31	Gold Finger (GF)	37
2.3.32	Power connector (PWR1)	39
3	BIOS Setup	40
3.1	Introduction	41
3.2	Starting Setup	41
3.3	Using Setup	42
3.4	Getting Help	43
3.5	In Case of Problems	43
3.6	BIOS setup	44
3.6.1	Main Menu	44
3.6.1.1	System Language	45
3.6.1.2	System Date	45
3.6.1.3	System Time	45
3.6.2	Advanced Menu	45
3.6.2.1	CPU Configuration	46
3.6.2.2	Power & Performance	47
3.6.2.2.1	CPU - Power Management Control	47
3.6.2.2.1.1	Config TDP Configurations	48
3.6.2.2.2	GT - Power Management Control	50
3.6.2.3	PCH-FW Configuration	51
3.6.2.3.1	Firmware Update Configuration	52
3.6.2.4	Trusted Computing	52
3.6.2.5	ACPI Settings	53
3.6.2.6	IT8528 Super IO Configuration	54
3.6.2.6.1	Serial Port 1 Configuration	55
3.6.2.6.2	Serial Port 2 Configuration	55
3.6.2.6.3	Serial Port 3 Configuration	56
3.6.2.6.4	Serial Port 4 Configuration	57
3.6.2.6.5	Serial Port 5 Configuration	57
3.6.2.6.6	Serial Port 6 Configuration	58
3.6.2.7	EC 8528 HW monitor	58
3.6.2.7.1	EC 8528 HW monitor-note	59
3.6.2.8	S5 RTC Wake Settings	60
3.6.2.9	Serial Port Console Redirection	60

3.6.2.9.1	Legacy Serial Redirection Port	61
3.6.2.10	USB Configuration	62
3.6.2.11	NVMe controller and Drive information	63
3.6.2.12	Network Stack Configuration	63
3.6.3	Chipset.....	64
3.6.3.1	System Agent (SA) Configuration.....	64
3.6.3.1.1	Memory Configuration	65
3.6.3.1.2	Graphics Configuration	66
3.6.3.2	PCH-IO Configuration.....	67
3.6.3.2.1	PCI Express Configuration	67
3.6.3.2.1.1	PCIe Root Port 8(LAN2-I210).....	68
3.6.3.2.1.2	PCIe Root Port 9(LAN3-I210/GF slot)	69
3.6.3.2.1.3	PCIe Root Port 10(M.2 KeyA)	70
3.6.3.2.1.4	PCIe Root Port 11(M.2 KeyB/SATA0).....	71
3.6.3.2.1.5	PCIe Root Port 13(GP PCIe4).....	72
3.6.3.2.2	SATA And RST Configuration	73
3.6.3.2.3	HD Audio Configuration	74
3.6.3.3	Board & Panel Configuration	74
3.6.4	Security.....	76
3.6.4.1	Secure Boot.....	77
4.6.4.1.1	Restore Factory Keys	78
4.6.4.1.2	Reset To Setup Mode.....	78
4.6.4.1.3	Key Management.....	79
3.6.5	Boot	80
3.6.6	Save and Exit	81
3.6.6.1	Save Changes and Reset.....	81
3.6.6.2	Discard Changes and Reset.....	81
3.6.6.3	Restore Defaults	82
3.6.6.4	Launch EFI Shell from filesystem device	82
4.	Drivers Installation.....	83
4.1	Install Chipset Driver	84
4.2	Install VGA Driver.....	85
4.3	Install ME Driver	86
4.4	Install Audio Driver (For Realtek ALC888S HD Audio).....	87
4.5	Install LAN Driver	88
4.6	Install RST Driver	90
5.	Mechanical Drawing	92

1. Getting Started

1.1 Safety Precautions

Warning!



Always completely disconnect the power cord from your chassis whenever you work with the hardware. Do not make connections while the power is on. Sensitive electronic components can be damaged by sudden power surges. Only experienced electronics personnel should open the PC chassis.

Caution!



Always ground yourself to remove any static charge before touching the CPU card. Modern electronic devices are very sensitive to static electric charges. As a safety precaution, use a grounding wrist strap at all times. Place all electronic components in a static-dissipative surface or static-shielded bag when they are not in the chassis.

1.2 Packing List

Before you begin installing your single board, please make sure that the following materials have been shipped:

- 1 x EMX-WHLGP motherboard
- 1 x SATA cable
- 1 x SATA power cable

Avalue design heatsink and heater solution for extended temperature support, but optional for customer purchase, please refer to Order information and Avalue sales.



If any of the above items is damaged or missing, contact your retailer.

1.3 Order information

Avalue P/N	Description	Note
EMX-WHLGP-430-A1R	Intel Celeron 4305UE Thin MiniITX Board	No heatsink, heater
EMX-WHLGP-43A1-01R		With heatsink, heater
EMX-WHLGP-814-A1R	Intel Core i3-8145UE Thin MiniITX Board	No heatsink, heater
EMX-WHLGP-81A1-01R		With heatsink, heater
EMX-WHLGP-836-A1R	Intel Core i5-8365UE Thin MiniITX Board	No heatsink, heater
EMX-WHLGP-83A1-01R		With heatsink, heater
EMX-WHLGP-866-A1R	Intel Core i7-8665UE Thin MiniITX Board	No heatsink, heater
EMX-WHLGP-86A1-01R		With heatsink, heater

1.4 Document Amendment History

Revision	Date	By	Comment
1 st	March 2020	Avalue	Initial Release
2 nd	June 2020	Avalue	Update Setting Jumpers & Connectors
3 rd	December 2020	Avalue	Update User condition suggestion
4 th	January 2021	Avalue	Update Setting Jumpers & Connectors
5 th	June 2021	Avalue	Update Setting Jumpers & Connectors

1.5 Manual Objectives

This manual describes in details Avalue Technology EMX-WHLGP Single Board.

We have tried to include as much information as possible but we have not duplicated information that is provided in the standard IBM Technical References, unless it proved to be necessary to aid in the understanding of this board.

We strongly recommend that you study this manual carefully before attempting to set up EMX-WHLGP or change the standard configurations. Whilst all the necessary information is available in this manual we would recommend that unless you are confident, you contact your supplier for guidance.

Please be aware that it is possible to create configurations within the CMOS RAM that make booting impossible. If this should happen, clear the CMOS settings, (see the description of the Jumper Settings for details).

If you have any suggestions or find any errors regarding this manual and want to inform us of these, please contact our Customer Service department with the relevant details.

1.6 System Specifications

System	
CPU	Onboard Whiskey Lake U Intel® Core™ SoC i7/i5/i3 & Celeron® BGA Processor
BIOS	AMI uEFI BIOS, 256Mbit SPI Flash ROM
I/O Chip	EC IT8528E
System Memory	Two 260-pin DDR4 2400 MHz SO-DIMM socket, supports up to 32GB Max (non ECC only)
Watchdog Timer	H/W Reset, 1sec. – 65535sec./min. 1sec. or 1min. step
H/W Status Monitor	CPU temperature monitoring Voltages monitoring CPU fan speed control
Expansion	1 x M.2 Type B 3042/2242/2260/2280 (with 1 x PCI-e x 1 (default) or SATA by BIOS), USB 2.0 with 1 x SIM card slot, support WWAN+GNSS or SSD with 1 x SIM card slot, support WWAN+GNSS or SSD. 1 x M.2 Key A 2230 support WiFi module (1 x PCI-e x 1 & USB 2.0 Signal) Expansion Design – Gold Finger with 1 x PCI-e x1 and 3rd LAN port by switch IC , 1 USB 2.0, SMBus , 1x PCI-e x 4
S3/S4	Yes (S0/S3/S4/S5)
I/O	
USB	3 x USB3.1 Gen1at I/O, USB Type C without DP Signal 4 x USB 2.0
GPIO	16-bits GPIO
Display	
Chipset	Intel® Processor Graphics
Resolution	3 x HDMI 1.4b: 3840 x 2160 @ 30 Hz, 2560 x 1600@ 30 Hz Note: HDMI1 signal from eDP converter to HDMI, thus HDMI1 does not support hot plug and audio output. Also, HDMI1 Signal share with LVDS, default LVDS.
Multiple Display	Triple Display Default: LVDS + HDMI + HDMI
HDMI	3 x HDMI 1.4b: 3840 x 2160 @ 30 Hz, 2560 x 1600@ 30 Hz
LCD Interface	2CH 18/24bits LVDS 1920 x 1080 (Chrontel. CH7511B eDP to LVDS Converter)
Audio	
AC97 Codec	Realtek ALC888S HD Audio Decoding Controller
Audio Amp	TI TPA3113D2PWP Stereo Class-D 6W x 2
Ethernet	
LAN Chip	1 x Intel® I219LM Gigabit Ethernet PHY 2 x Intel® I210IT PCI-e Gigabit Ethernet (Co-lay Intel® I211AT/I210AT)

EMX-WHLGP User's Manual

Ethernet Interface	Gigabit Ethernet
Internal I/O Connectors	
Fan	1 x 1 x 4 pin, pitch 2.54mm CPU fan connector with smart fan function supported
System 1 I2C	1 x 1 x 5 pin, pitch 2.00mm, +3.3V Level
Buzzer	Onboard
CMOS Battery	1 x horizontal type battery connector (Battery cable 170mm length)
Power ON	1 x 2 x 5 pin, pitch 2.54mm connector for front panel 1 1 x 2 x 5 pin, pitch 2.54mm connector for front panel 2
Audio	1 x 2 x 5 pin, pitch 2.54mm connector for front Audio
External I/O Connector	<p>Storage:</p> <p>1 x M.2 Type B 3042/2242/2260/2280 (with 1 x PCI-e x 1 (default) or SATA by BIOS), USB 2.0 with 1 x SIM card slot, support WWAN+GNSS or SSD with 1 x SIM card slot, support WWAN+GNSS or SSD</p> <p>1 x SATA III 1 x SATA power box connectors</p> <p>COM:</p> <p>COM 1 & COM2: COM 1 & COM2 support RS232/422/485 connector, with / +5V & +12V Supported and RS422/485 by BIOS setting</p> <p>2 x 2 x 5 pin, pitch 2.00mm connector support RS-232 connector, Pin 9 with / +5V & +12V Supported</p> <p>2 x 2 x 3 pin, pitch 2.00mm connector support RS422/485 connector, Pin 5 with / +5V Supported</p> <p>COM3 to 6: 1 x 2 x 20 pin, pitch 2.00mm connector for COM3~6: support RS-232 connector</p> <p>2 x 2 x 5 pin, pitch 2.54mm connector for 4 USB 2.0</p> <p>1 x 2 x 10 pin, pitch 2.00mm connector for GPIO: 16 bits & +3.3S Level SMBus</p> <p>1 x 2 x 4 pin, pitch 2.00mm connector for PS2 KB/MS</p> <p>1 x 2 x 4 pin, pitch 2.00mm connector for BIOS SPI</p> <p>1 x 2 x 5 pin, pitch 2.00mm connector for EC SPI</p> <p>1 x 2 x 5 pin, pitch 2.0mm connector for LPC debug.</p> <p>1 x horizontal type battery connector (Battery cable 170mm length)</p> <p>1 x 2 x 5 pin, pitch 2.54mm connector for front panel 1</p> <p>1 x 2 x 5 pin, pitch 2.54mm connector for front panel 2</p> <p>1 x 2 x 20 pin, pitch 1.25mm connector for LVDS (must be using WF40H6-7GAA178 connector)</p> <p>1 x 1 x 5 pin, pitch 2.00mm Wafer connector for LCD inverter backlight connector (5V/12V)</p> <p>1 x 1 x 3 pin, pitch 2.54mm connector LCD backlight brightness adjustment</p>

	(PWM/DC) 1 x 2 x 5 pin, pitch 2.54mm connector for front Audio 1 x 4 pin, pitch wafer 2.00mm connector for 6W x 2 Speaker 1 x 3 pin, pitch 2.00mm connector for CMOS clear 1 x 1 x 4 pin, pitch 2.54mm CPU fan connector with smart fan function supported 3 x 1 x 4 pin, pitch 2.00mm connector for LAN Activity Indicator LED 1 x 2 x 2 pin, pitch 4.20mm connector for power input connector 1 x 1 x 3 pin, pitch 2.54mm connector for AT/ATX mode 6 x 1 x 2 pin, pitch 2.00mm box connector support heater Fanless Operating
Rear I/O Connectors	
USB	4 x USB3.1 Gen1
LAN	1 x Intel® I219LM Gigabit Ethernet PHY 2 x Intel® I210IT PCI-e Gigabit Ethernet (Co-lay Intel® I211AT)
HDMI	3 x HDMI
LED	3 x 1 x 4 pin, pitch 2.00mm connector for LAN Activity Indicator LED
Rear Side External I/O Connector	3 x RJ-45 3 x HDMI 3 x USB3.1 Gen1 at I/O, USB Type C without DP Signal Mic-in with Line-out in one connector
Mechanical & Environmental	
Power Requirement	DC in +12V~24V
ACPI	Single power ATX Support S0, S3, S4, S5 ACPI 5.0 Compliant
Power Type	AT / ATX mode Switchable Through Jumper
Operating Temp.	-20~60°C (-4~140°F), with heatsink, heater, 60°C with 0.5 m/s air flow
Storage Temp.	-40~ +75°C
Operating Humidity	40°C @ 95% Relative Humidity, Non-condensing
Size (L x W)	6.7" x 6.7" (170mm x 170mm)
Weight	0.40 kg
OS Support	Win10 64bit, Linux



Note: Specifications are subject to change without notice.

EMX-WHLGP User's Manual

User condition suggestion:

1. EMX-WHLGP standard package does not include I/O bracket due to LAN 2 & 3 connector exceed standard Thin MiniITX chassis. Customer need to customized chassis and I/O bracket base on needed application.
2. HDMI1 signal from eDP converter to HDMI, thus HDMI1 does not support hot plug and audio output. Also, HDMI1 Signal share with LVDS, default LVDS.
3. With heatsink and heater, it takes around 8 to 10 minutes for EMX-WHLGP boot up from -20°C.
4. It is suggested to use more than 84Watt Power adapter for EMX-WHLGP , especially for 4 core CPU i7-8665UE, maximum current 70A, which 120Watt power adapter is required.
Please refer to Avalue Board Product Design Verification report for detail testing data.

1.7 Architecture Overview—Block Diagram

The following block diagram shows the architecture and main components of EMX-WHLGP.

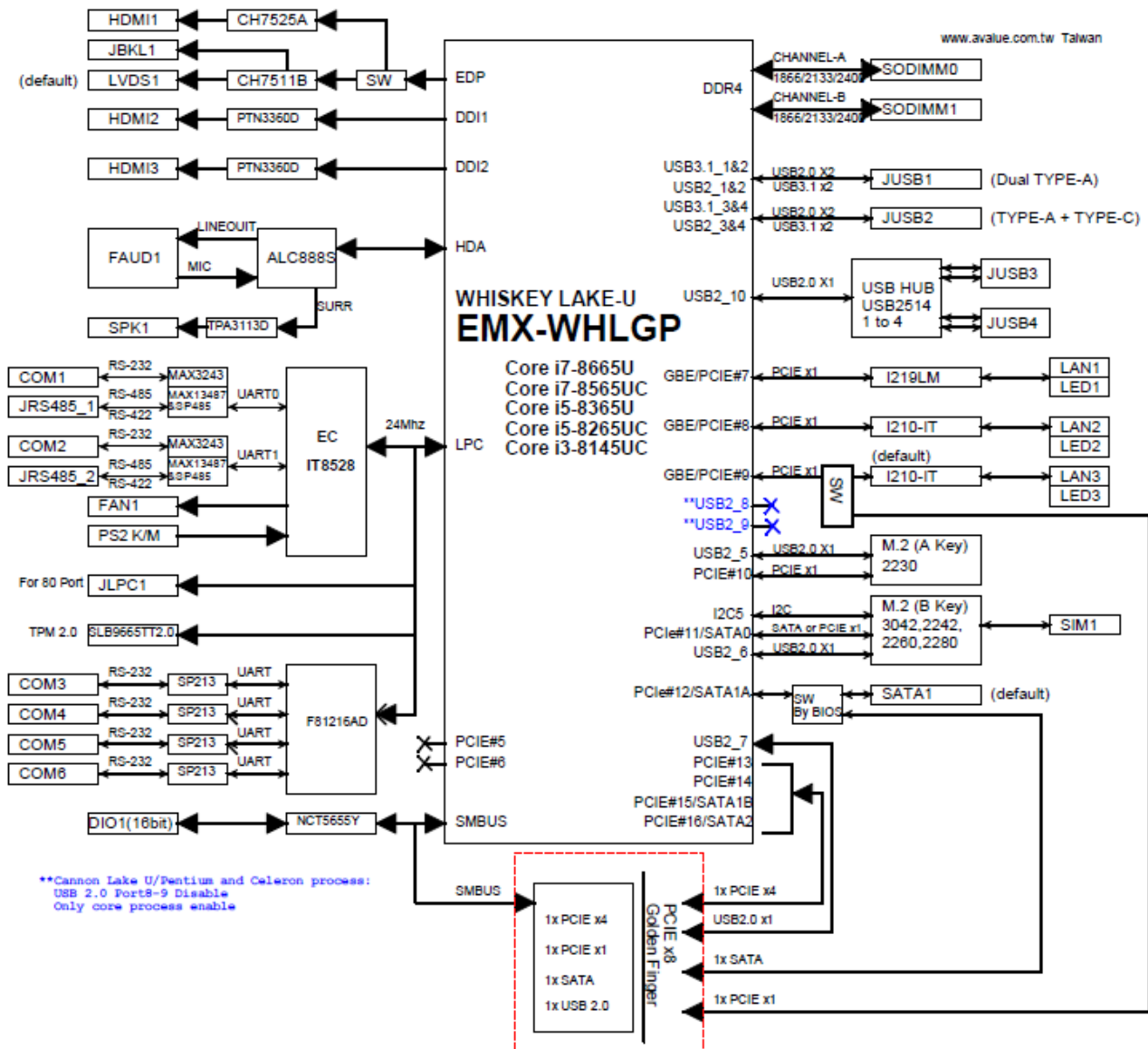

1.8 Expansion design

Expansion Design – Gold Finger

PCIEx8 Golden Finger

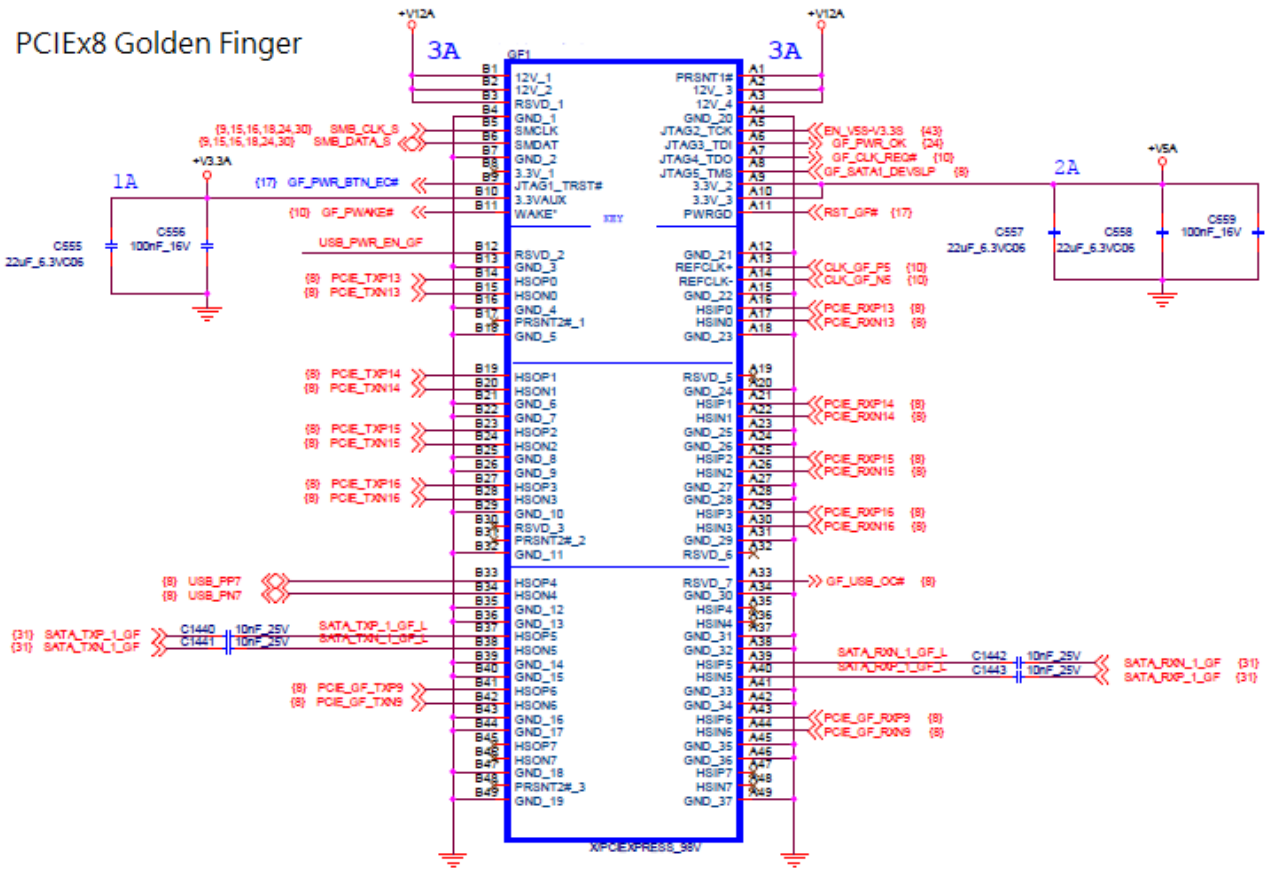

2. Hardware Configuration

2.1 Product Overview

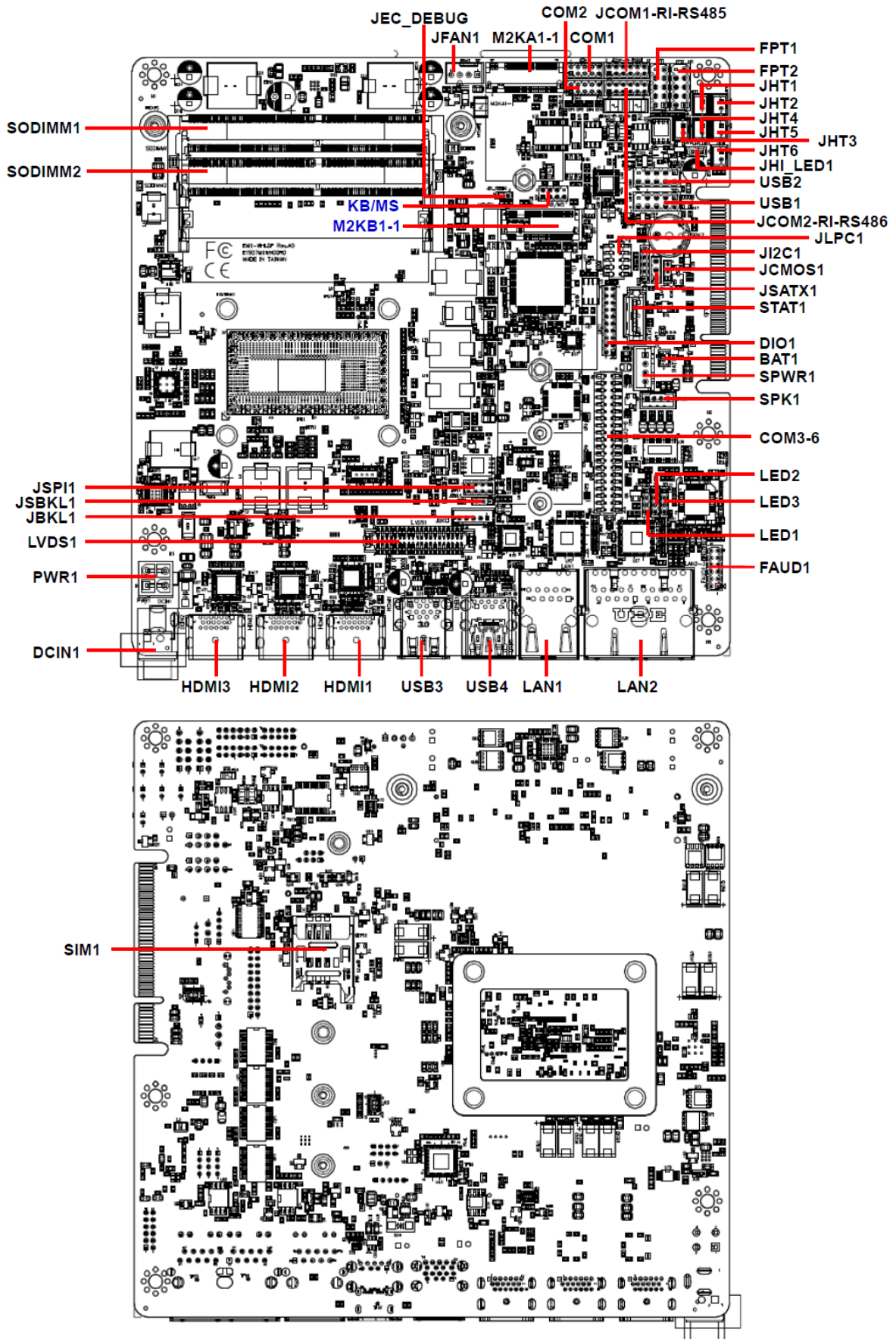

2.2 Jumper and Connector List

You can configure your board to match the needs of your application by setting jumpers. A jumper is the simplest kind of electric switch.

It consists of two metal pins and a small metal clip (often protected by a plastic cover) that slides over the pins to connect them. To “close” a jumper you connect the pins with the clip. To “open” a jumper you remove the clip. Sometimes a jumper will have three pins, labeled 1, 2, and 3. In this case, you would connect either two pins.

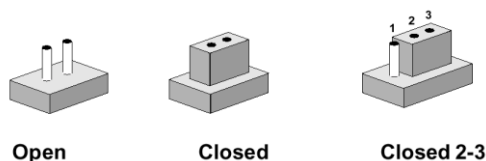

The jumper settings are schematically depicted in this manual as follows:



A pair of needle-nose pliers may be helpful when working with jumpers.

Connectors on the board are linked to external devices such as hard disk drives, a keyboard, or floppy drives. In addition, the board has a number of jumpers that allow you to configure your system to suit your application.

If you have any doubts about the best hardware configuration for your application, contact your local distributor or sales representative before you make any changes.

The following tables list the function of each of the board's jumpers and connectors.

Jumpers

Label	Function	Note
JSBKL1	LVDS Back Light power selection	3 x 1 header, pitch 2.00mm
JSATX1	AT/ATX Power Mode Select	3 x 1 header, pitch 2.54mm
JCOMS1	Clear CMOS	3 x 1 header, pitch 2.00mm
JCOM1-RI-RS485	Serial port 1/2 pin9 signal select	6 x 2 header, pitch 2.00mm
JCOM2-RI-RS486	Serial port 1/2 pin9 signal select	6 x 2 header, pitch 2.00mm

Connectors

Label	Function	Note
FPT1/2	Miscellaneous setting connector 1/2	5 x 2 header, pitch 2.54mm
SODIMM1/2	206-pin DDR4 SO-DIMM socket	
FAUD1	Front Audio connector	6 x 2 header, pitch 2.00mm

EMX-WHLGP User's Manual

JBKL1	LCD Inverter connector	5 x 1 wafer, pitch 2.00mm
JSPI1	SPI connector	4 x 2 header, pitch 2.00mm
JEC_DEBUG	EC Debug	2 x 1 header, pitch 2.00mm
COM1/2	Serial Port 1/2 connector	5 x 2 header, pitch 2.00mm
COM3-6	Serial Port 3-6 connector	20 x 2 header, pitch 2.00mm
DIO1	General purpose I/O connector	10 x 2 header, pitch 2.00mm
SPK1	Speaker connector	4 x 1 wafer, pitch 2.00mm
LVDS1	LVDS Connector	20 x 2 wafer, pitch 1.25mm
USB1/2	USB connector 1/2	5 x 2 header, pitch 2.54mm
USB3/4	USB connector 3/4	
LAN1/2	RJ-45 Ethernet 1/2	
LED1/2/3	LED indicator connector 1/2/3	4 x 1 header, pitch 2.00mm
M2KA1-1	M.2 2230 Key A slot	
M2KB1-1	M.2 3042/2242/2260/2280 Key B Slot	
JLPC	LPC connector	5 x 2 header, pitch 2.00mm
DCIN1	DC Power-in connector	
PWR1	Power connector	2 x 2 wafer, pitch 4.20mm
SATA1	Serial ATA connector	SATA1 is not functioning in EMX-SKLGP-3855 SKU
SPWR1	SATA Power connector	4 x 1 wafer, pitch 2.54mm
JI2C1	JI2C connector	5 x 1 header, pitch 2.00mm
HDMI1/2/3	HDMI connector 1/2/3	
JFAN1	CPU Fan connector	1 x 4 wafer, pitch 2.54 mm
SIM1	SIM card slot	
KB/MS	PS/2 keyboard & mouse header	4 x 2 header, pitch 2.00mm
BAT1	Battery connector	2 x 1 wafer, pitch 1.25mm
JHT_LED	LED Indicator for Heater	2 x 1 header, pitch 2.54mm
JHT1/23/4/5/6	CPU Heatsink Heater Connector	2 x 1 header, pitch 2.00mm
GF	Gold Finger	

2.3 Setting Jumpers & Connectors

2.3.1 Serial port 1/2 pin9 signal select (JCOM1-RI-RS485)

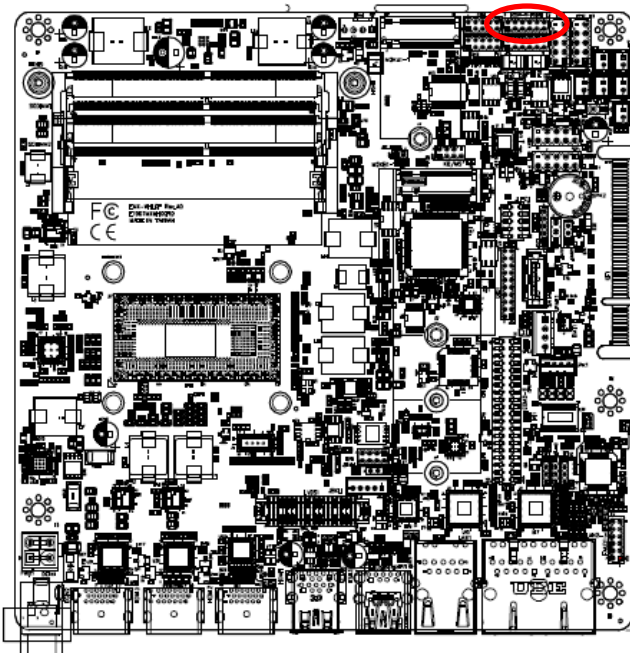

Ring*

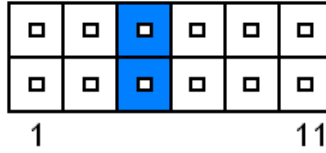

+12V

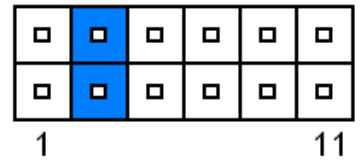

+5V

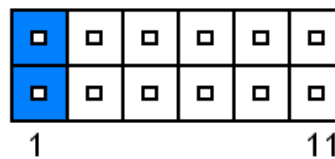

* Default

2.3.2 Serial port 1/2 pin9 signal select (JCOM2-RI-RS486)

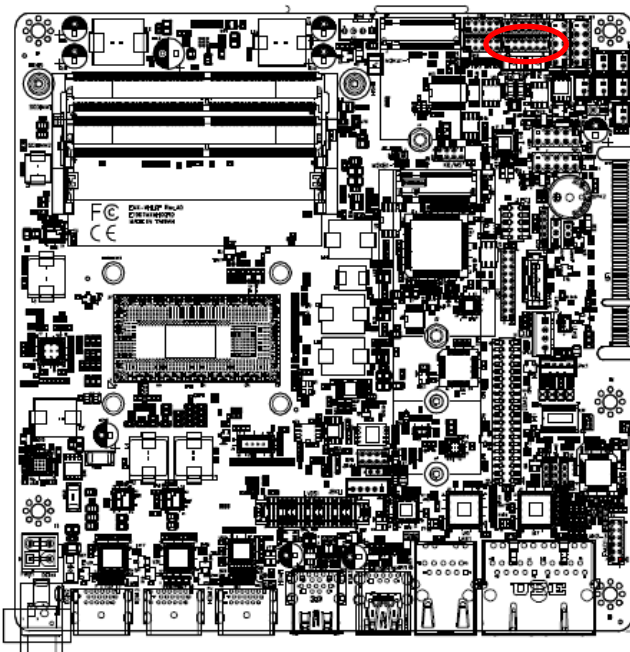

Ring*

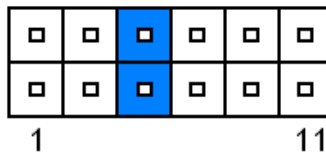

+12V

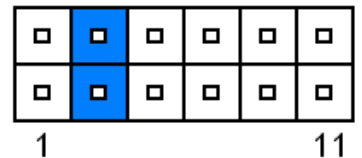

+5V

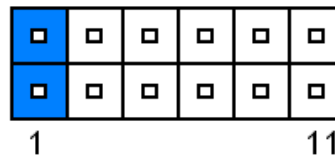

* Default

2.3.3 LVDS Back Light power selection (JSBKL1)

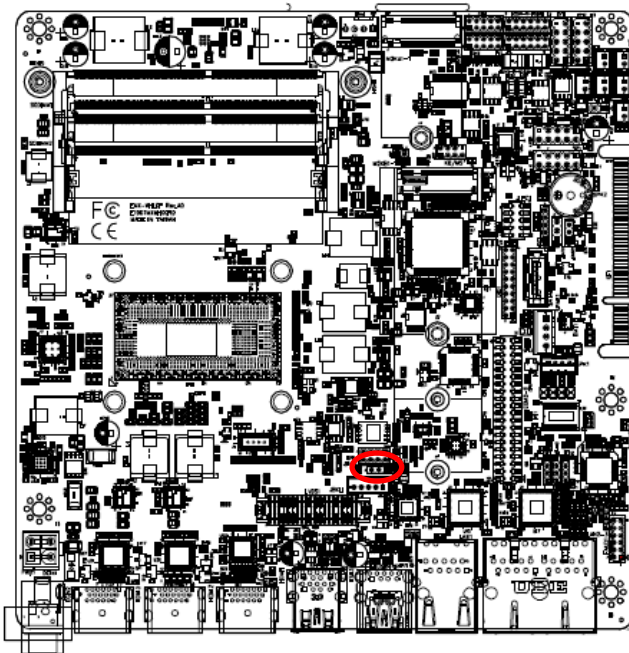

PWM Mode*

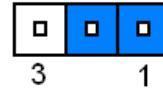

3

1

DC Mode

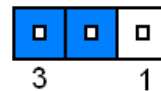

3

1

* Default

2.3.4 AT/ATX Power Mode Select (JSATX1)

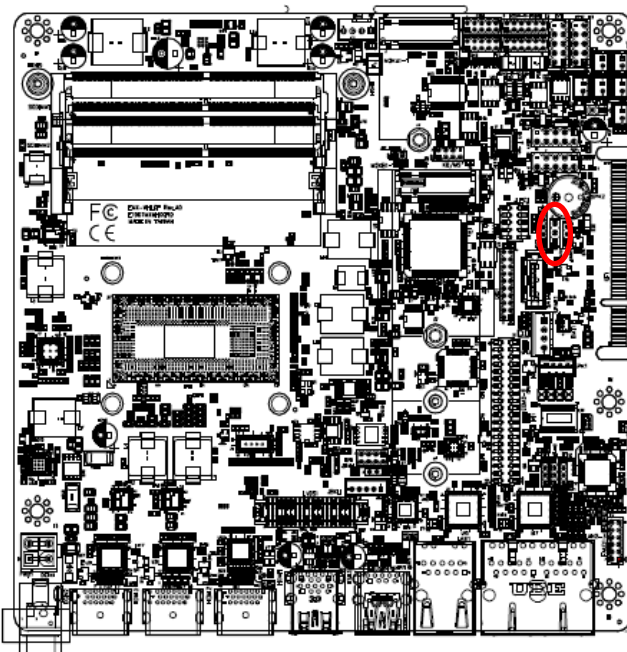

ATX*

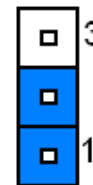

3

1

AT

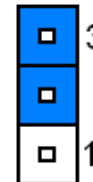

3

1

* Default

2.3.5 Clear CMOS (JCMOS1)

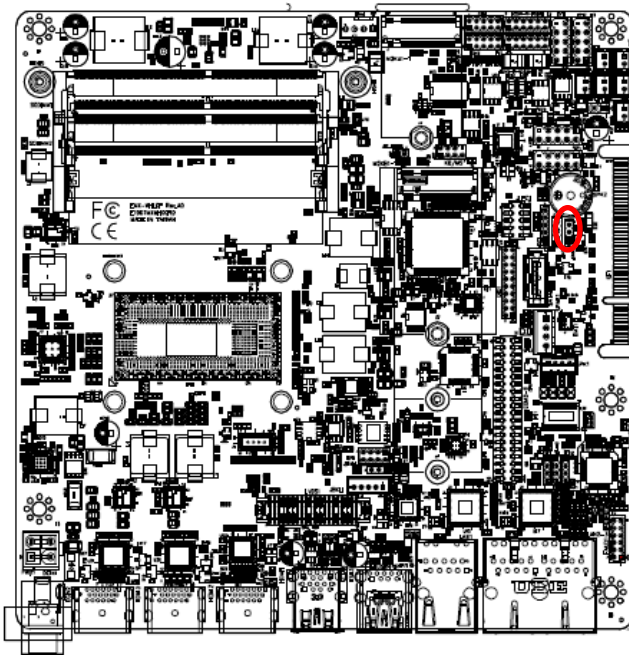

Protect*

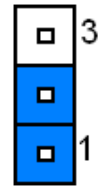

Clear CMOS

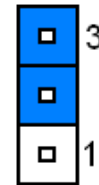

* Default

2.3.6 LCD Inverter connector (JBKL1)

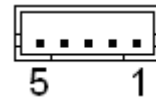
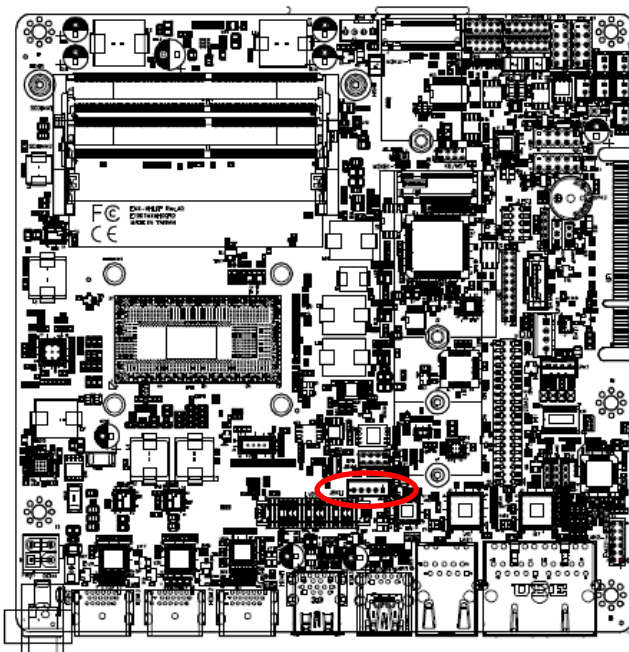

PIN	Signal
1	+12V
2	GND
3	LVDS_BKLT_EN
4	LVDS_BKLTCTL
5	+5V

2.3.7 Serial port 1 connector (COM1)

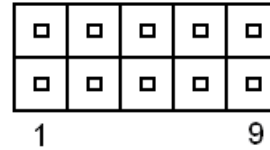
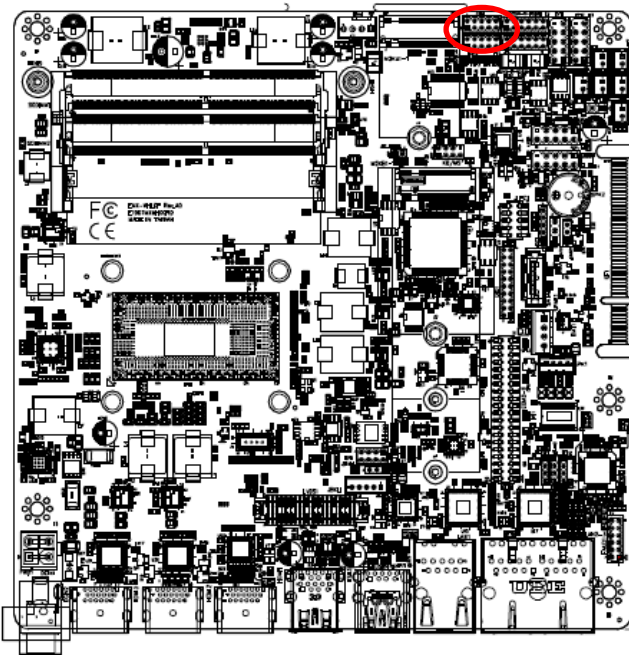

Signal	PIN	PIN	Signal
COM_DCD#_1	1	2	COM_RXD_1
COM_TXD_1	3	4	COM_DTR#_1
GND	5	6	COM_DSR#_1
COM_RTS#_1	7	8	COM_CTS#_1
COM_R#_1_R	9	10	NC

2.3.8 Serial port 2 connector (COM2)

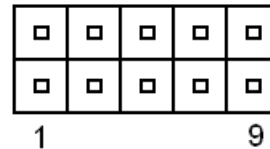
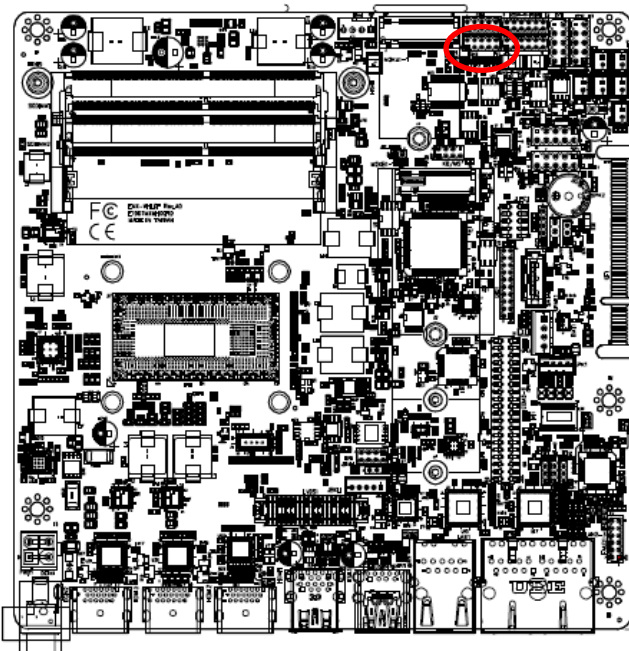

Signal	PIN	PIN	Signal
COM_DCD#_2	1	2	COM_RXD_2
COM_TXD_2	3	4	COM_DTR#_2
GND	5	6	COM_DSR#_2
COM_RTS#_2	7	8	COM_CTS#_2
COM_R#_2_R	9	10	NC

2.3.9 General purpose I/O connector (DIO1)

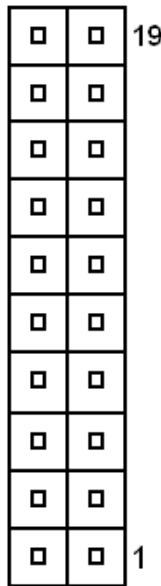
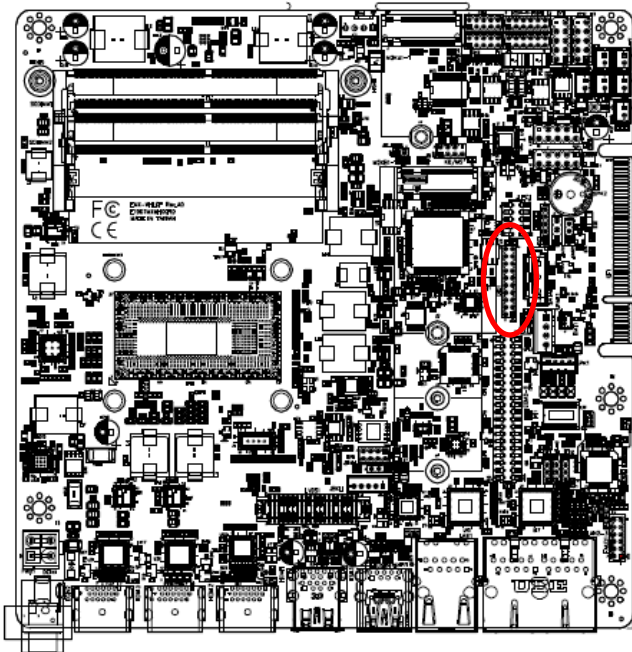

Signal	PIN	PIN	Signal
DI0	1	2	DO0
DI1	3	4	DO1
DI2	5	6	DO2
DI3	7	8	DO3
DI4	9	10	DO4
DI5	11	12	DO5
DI6	13	14	DO6
DI7	15	16	DO7
SMB_CLK_S	17	18	SMB_DATA_S
GND	19	20	+5V

2.3.10 SPI connector (JSPI1)

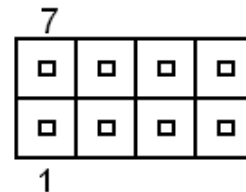
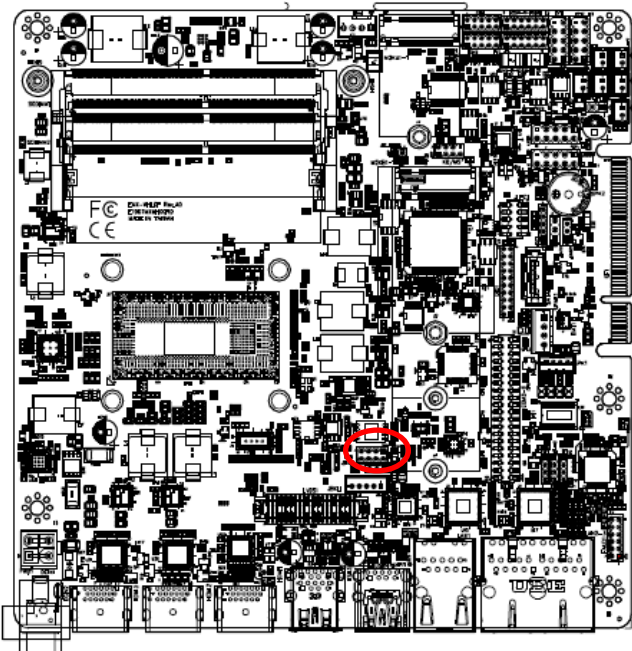

Signal	PIN	PIN	Signal
+3.3A_SPI	1	2	GND
SPI0_CS0#	3	4	SPI_CLK
SPI_SO	5	6	SPI_SI
HOLD#	7	8	SPI_WP#

2.3.11 Serial port 3-6 connector (COM3-6)

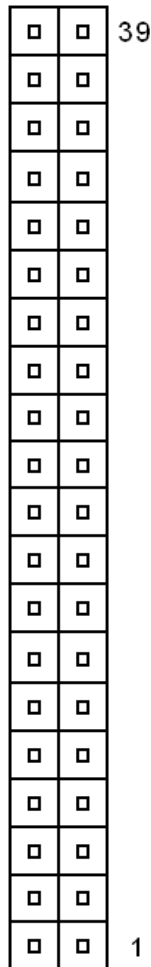
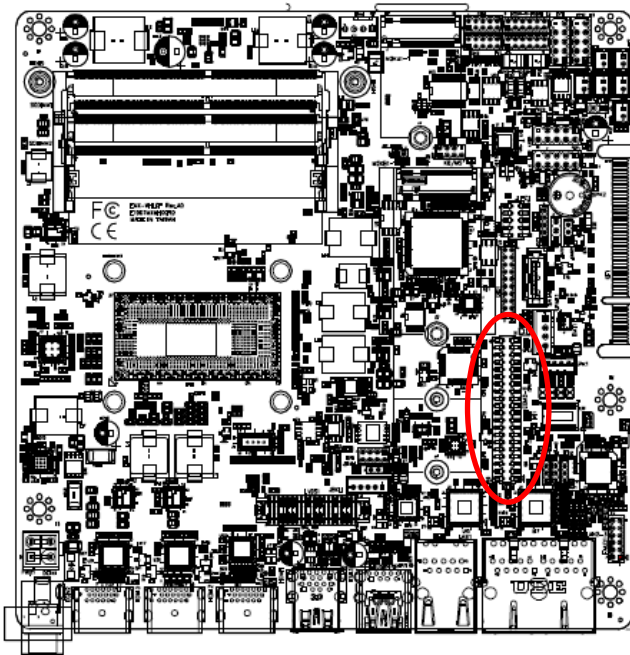

Signal	PIN	PIN	Signal
NC	40	39	COM_R#_6
COM_CTS#_6	38	37	COM_RTS#_6
COM_DSR#_6	36	35	GND
COM_DTR#_6	34	33	COM_TXD_6
COM_RXD_6	32	31	COM_DCD#_6
NC	30	29	COM_R#_5
COM_CTS#_5	28	27	COM_RTS#_5
COM_DSR#_5	26	25	GND
COM_DTR#_5	24	23	COM_TXD_5
COM_RXD_5	22	21	COM_DCD#_5
NC	20	19	COM_R#_4
COM_CTS#_4	18	17	COM_RTS#_4
COM_DSR#_4	16	15	GND
COM_DTR#_4	14	13	COM_TXD_4
COM_RXD_4	12	11	COM_DCD#_4
NC	10	9	COM_R#_3
COM_CTS#_3	8	7	COM_RTS#_3
COM_DSR#_3	6	5	GND
COM_DTR#_3	4	3	COM_TXD_3
COM_RXD_3	2	1	COM_DCD#_3

2.3.12 SATA Power connector (SPWR1)

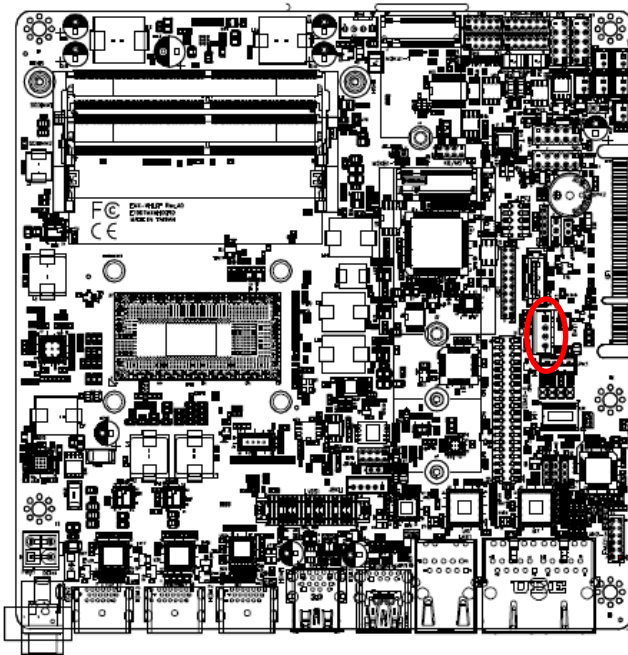

PIN	Signal
1	+V5S_SATA1
2	GND
3	GND
4	+V12S_SATA1

2.3.13 CPU Fan connector (JFAN1)

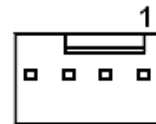
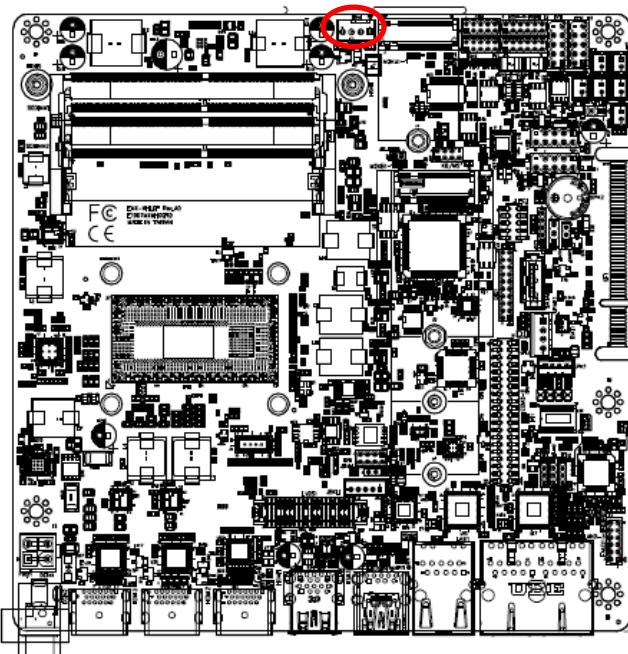

PIN	Signal
1	GND
2	+12V_FAN1
3	CPUFANIN
4	FAN_PWM0

2.3.14 USB connector 1(USB1)

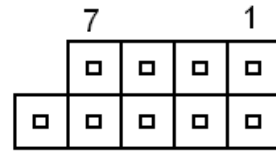
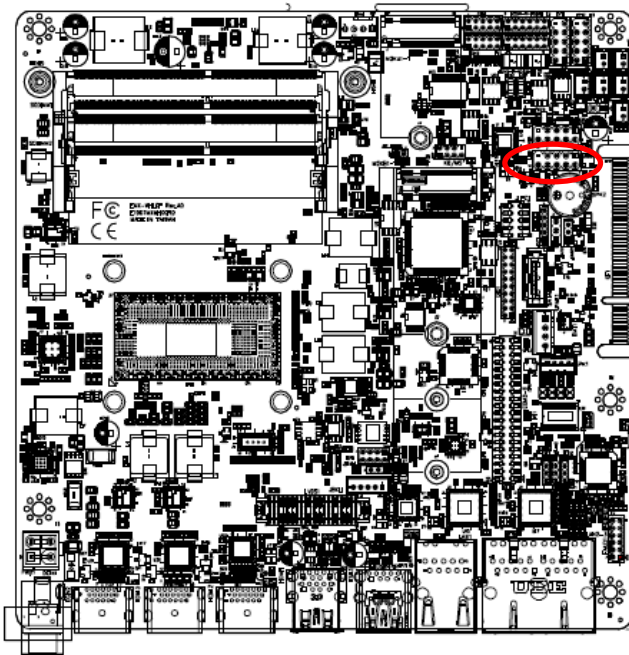

Signal	PIN	PIN	Signal
+V5A_HUB1-4	1	2	+V5A_HUB1-4
UHUB_DM1_R	3	4	UHUB_DM2_R
UHUB_DP1_R	5	6	UHUB_DP2_R
GND	7	8	GND
		10	NC

2.3.15 USB connector 2(USB2)

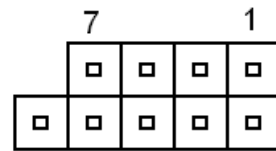
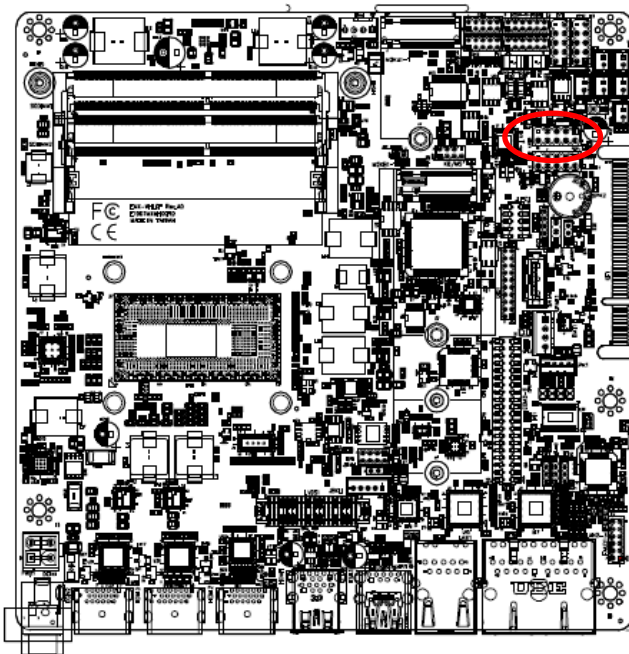

Signal	PIN	PIN	Signal
+V5A_HUB1-4	1	2	+V5A_HUB1-4
UHUB_DM3_R	3	4	UHUB_DM4_R
UHUB_DP3_R	5	6	UHUB_DP4_R
GND	7	8	GND
		10	NC

2.3.16 LVDS connector (LVDS1)

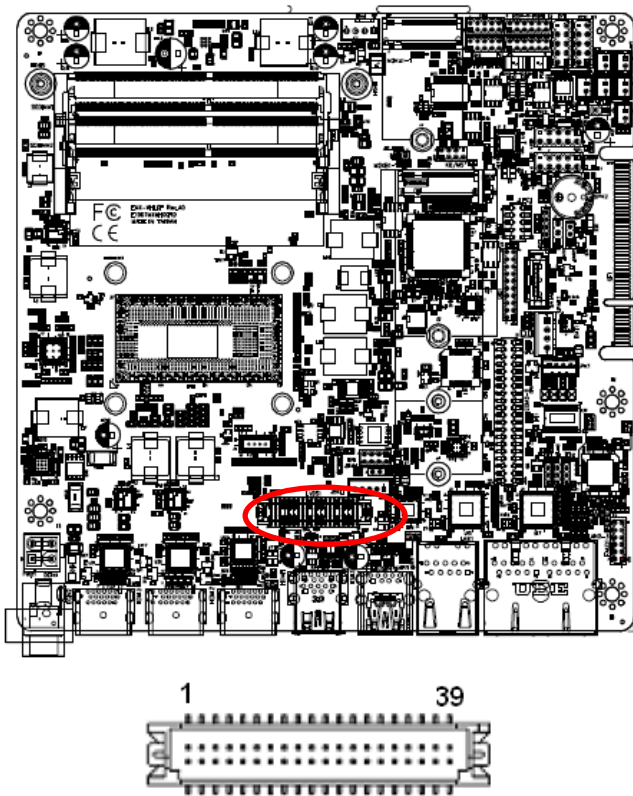

Signal	PIN	PIN	Signal
+5V_LVDS	2	1	+3.3V_LVDS
+5V_LVDS	4	3	+3.3V_LVDS
NC	6	5	NC
GND	8	7	GND
LVDS_DATA0_P	10	9	LVDS_DATA1_P
LVDS_DATA0_N	12	11	LVDS_DATA1_N
GND	14	13	GND
LVDS_DATA2_P	16	15	LVDS_DATA3_P
LVDS_DATA2_N	18	17	LVDS_DATA3_N
GND	20	19	GND
LVDS_DATA4_P	22	21	LVDS_DATA5_P
LVDS_DATA4_N	24	23	LVDS_DATA5_N
GND	26	25	GND
LVDS_DATA6_P	28	27	LVDS_DATA7_P
LVDS_DATA6_N	30	29	LVDS_DATA7_N
GND	32	31	GND
LVDS_CLK1_P	34	33	LVDS_CLK2_P
LVDS_CLK1_N	36	35	LVDS_CLK2_N
GND	38	37	GND
+12V	40	39	+12V

2.3.17 Front Audio connector (FAUD1)

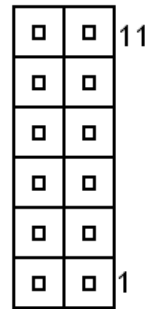
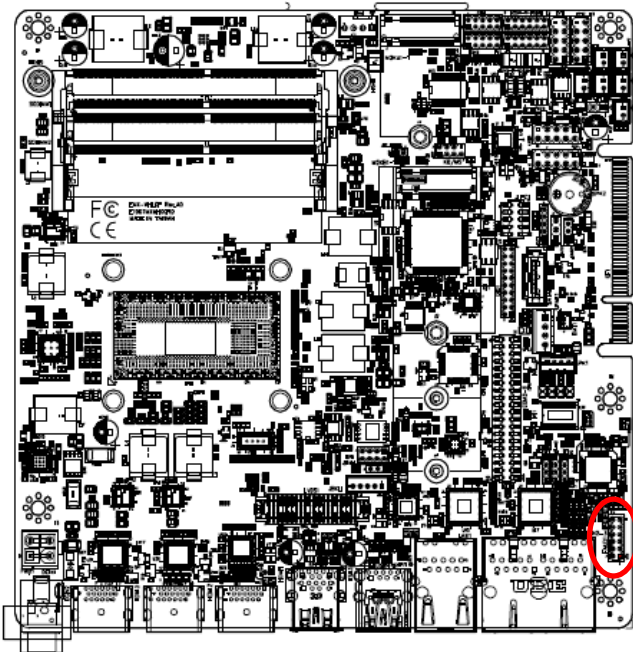

Signal	PIN	PIN	Signal
GND_AUD	12	11	MIC1_JD
NC	10	9	LINEOUT1_JD
MIC1_LIN	8	7	MIC1_RIN
NC	6	5	NC
GND_AUD	4	3	GND_AUD
LINEOUT_L	2	1	LINEOUT_R

2.3.18 EC Debug (JEC_DEBUG)

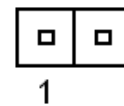
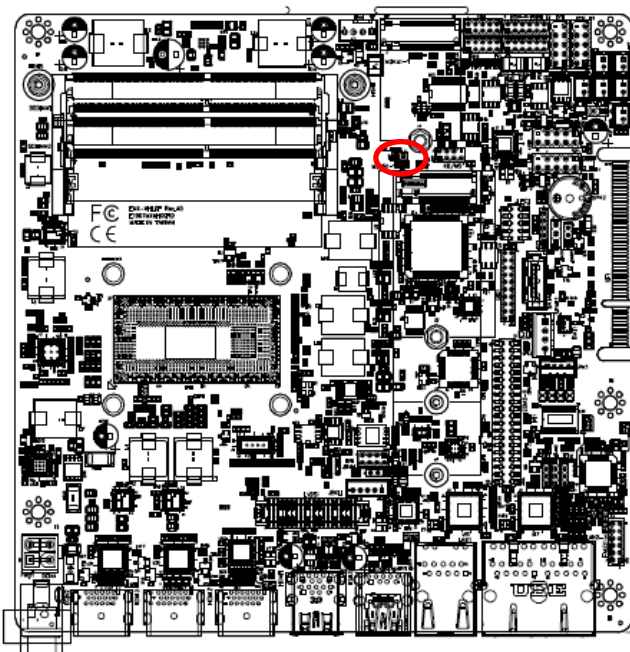

PIN	Signal
1	EC_SMCLK
2	EC_SMDAT

2.3.19 Battery connector (BAT1)

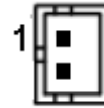
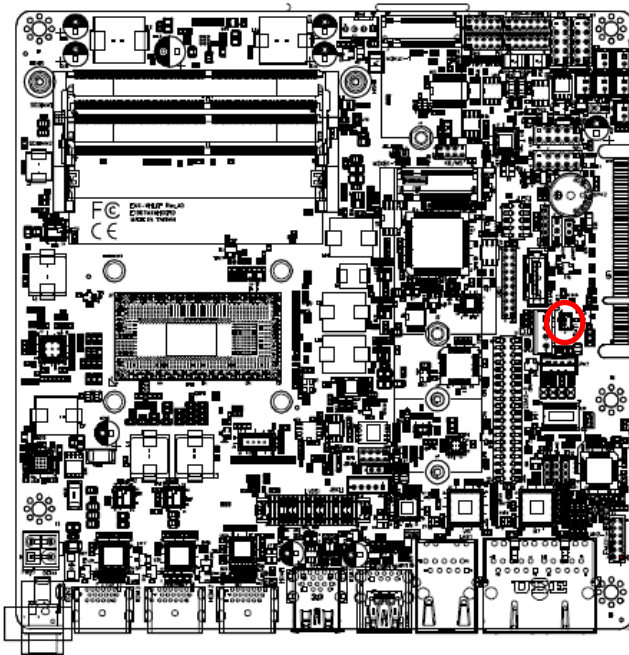

PIN	Signal
1	+VRTCBAT
2	GND

2.3.20 PS/2 keyboard & mouse header (KB/MS)

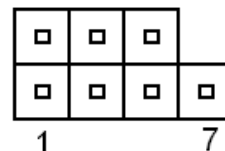
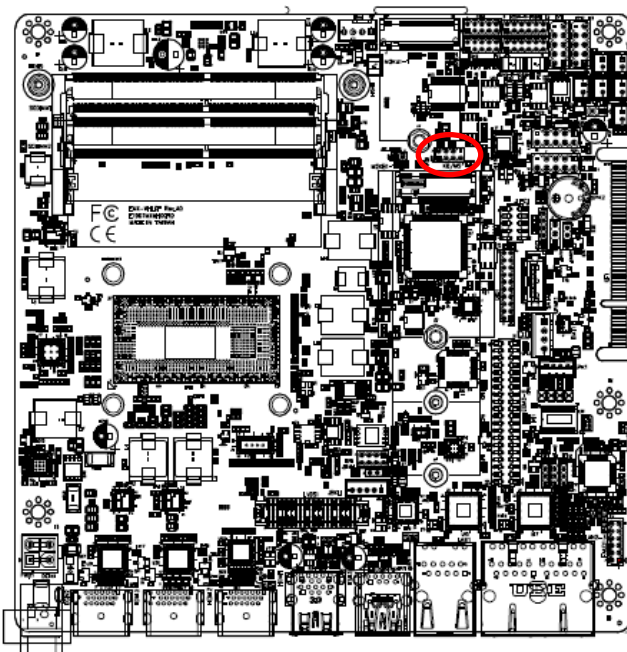

Signal	PIN	PIN	Signal
KBDAT	1	2	KBCLK
GND	3	4	5V
MSDAT	5	6	MSCLK
NC	7		

2.3.21 Miscellaneous setting connector 1 (FPT1)

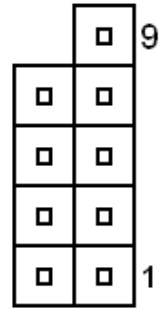
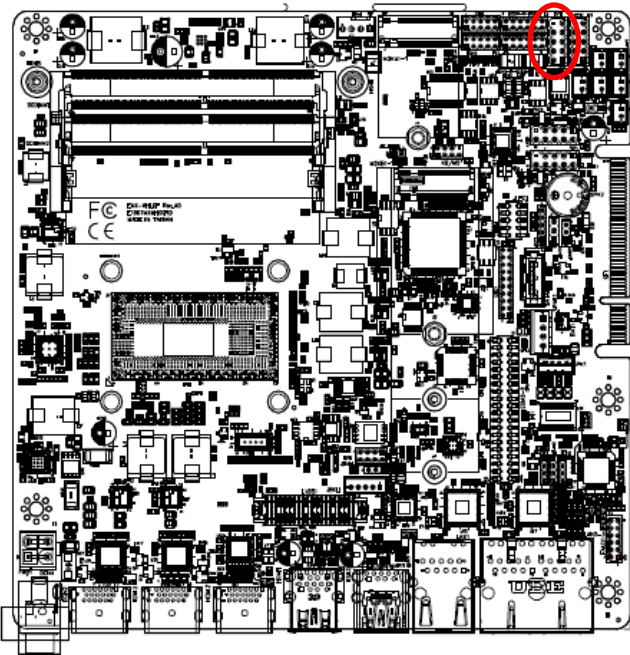

Signal	PIN	PIN	Signal
		9	NC
-PWR_BTN	8	7	-Reset
+PWR_BTN	6	5	+Reset
-PWR_LED	4	3	-HD_LED
+PWR_LED	2	1	+HD_LED

2.3.22 Miscellaneous setting connector 2 (FPT2)

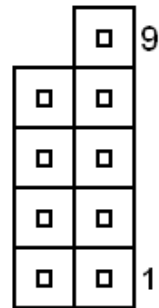
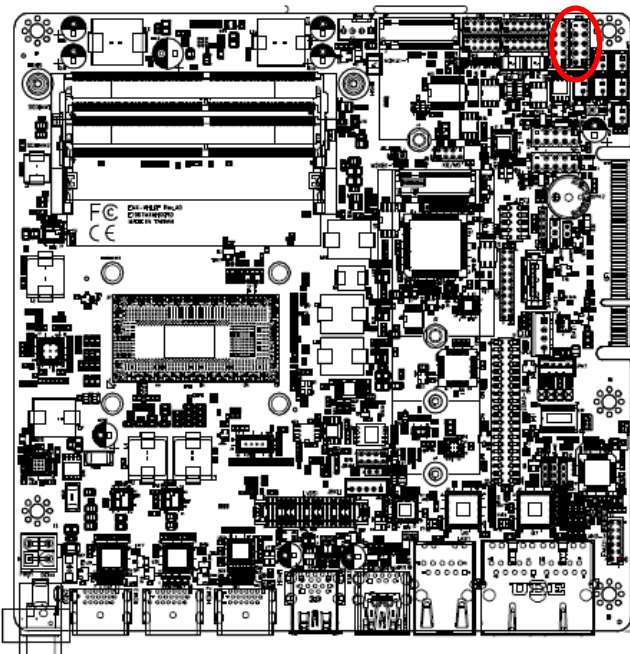

Signal	PIN	PIN	Signal
Speaker+	1	2	BLK_VR(10K)
NC	3	4	BLK_UP
NC	5	6	BLK_DN
Speaker-	7	8	GND
NC	9	10	

2.3.23 LED indicator connector 1 (LED1)

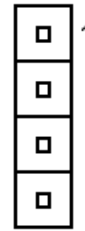
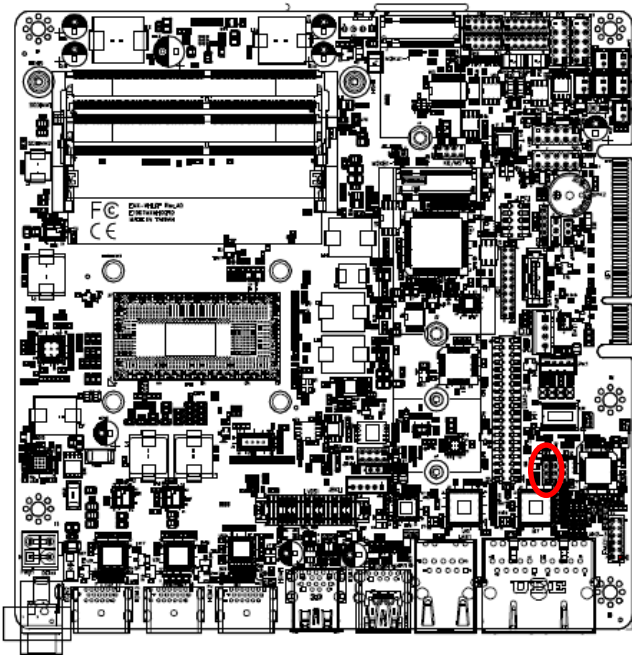

PIN	Signal
1	LAN1_ACT_P
2	LAN1_ACT_N
3	LAN1_100#_LED
4	LAN1_1000#_LED

2.3.24 LED indicator connector 2 (LED2)

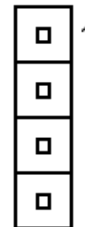
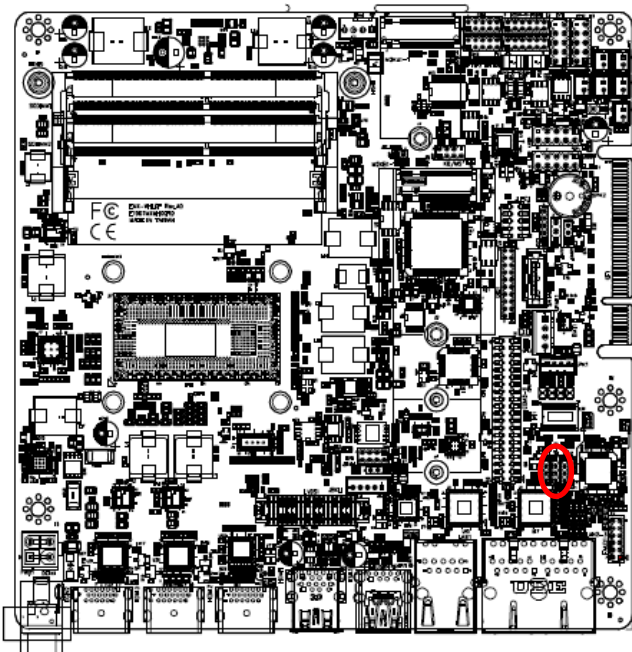

PIN	Signal
1	LAN2_ACT_P
2	LAN2_ACT_N
3	LAN2_100#_LED
4	LAN2_1000#_LED

2.3.25 LED indicator connector 3 (LED3)

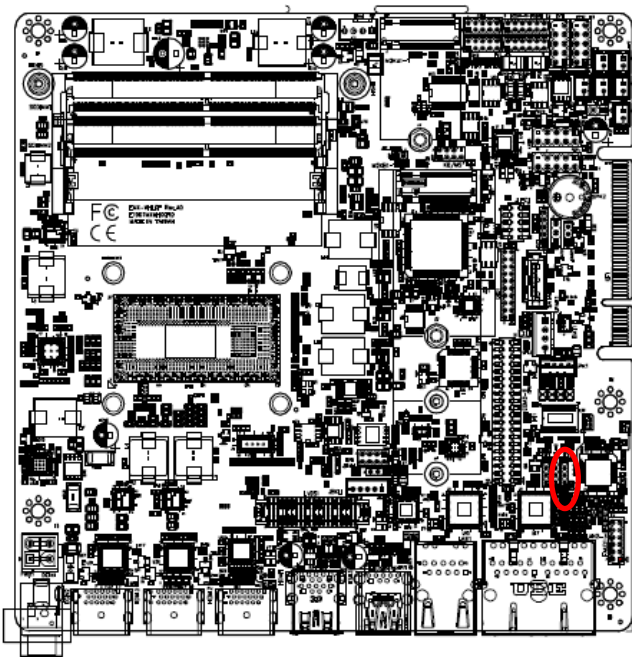

PIN	Signal
1	LAN3_ACT_P
2	LAN3_ACT_N
3	LAN3_100#_LED
4	LAN3_1000#_LED

2.3.26 Speaker connector (SPK1)

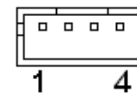
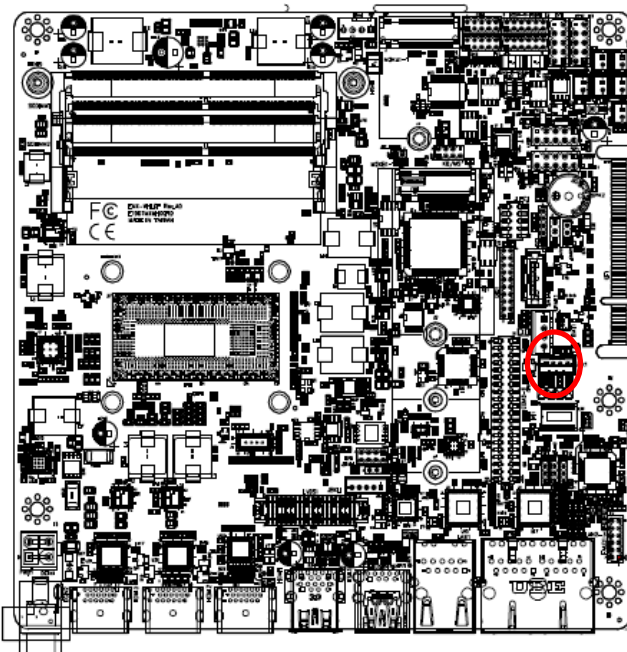

PIN	Signal
1	SPK_L+
2	SPK_L-
3	SPK_R+
4	SPK_R-

2.3.27 JI2C connector (JI2C1)

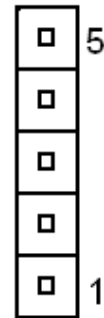
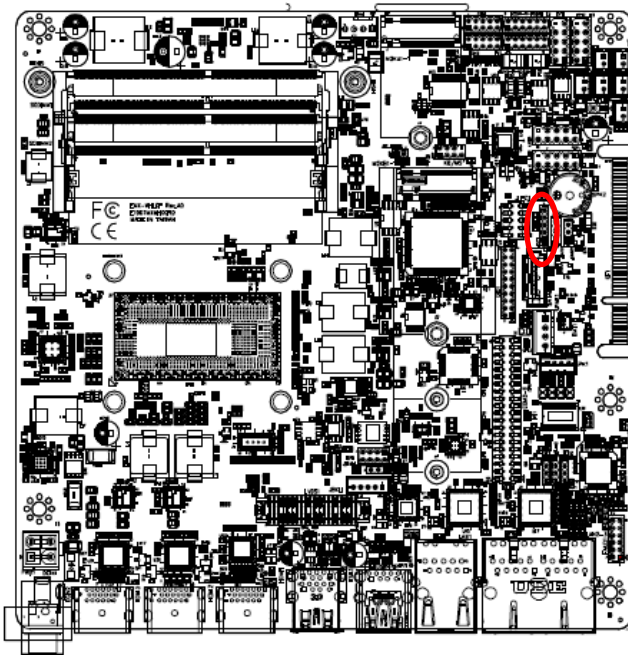

PIN	Signal
1	+3.3V
2	INT_I2C0#
3	I2C0_CLK
4	I2C0_DATA
5	GND

2.3.28 LPC connector (JLPC1)

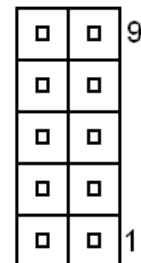
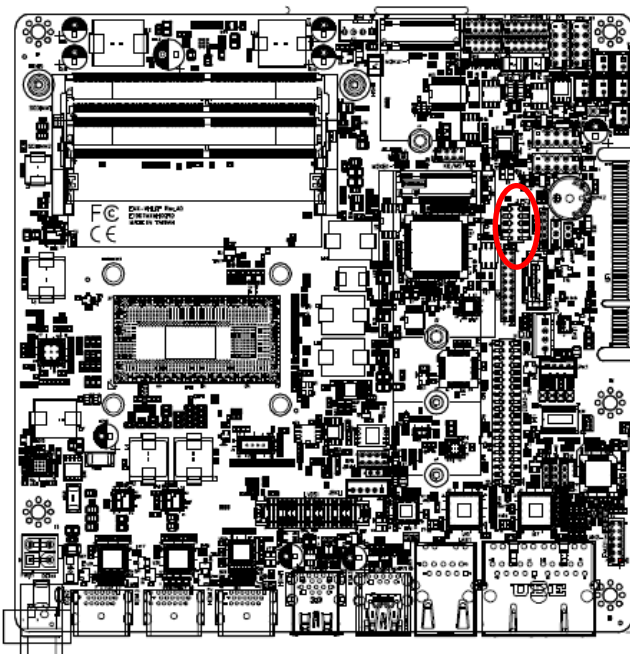

Signal	PIN	PIN	Signal
GND	10	9	LPC_SERIRQ
LPC_CLK	8	7	LPC_AD3
LPC_FRAME#	6	5	LPC_AD2
PCH_PLTRST#	4	3	LPC_AD1
+3.3V	2	1	LPC_AD0

2.3.29 CPU Heatsink Heater Connector (JHT1/2/3/4/5/6)

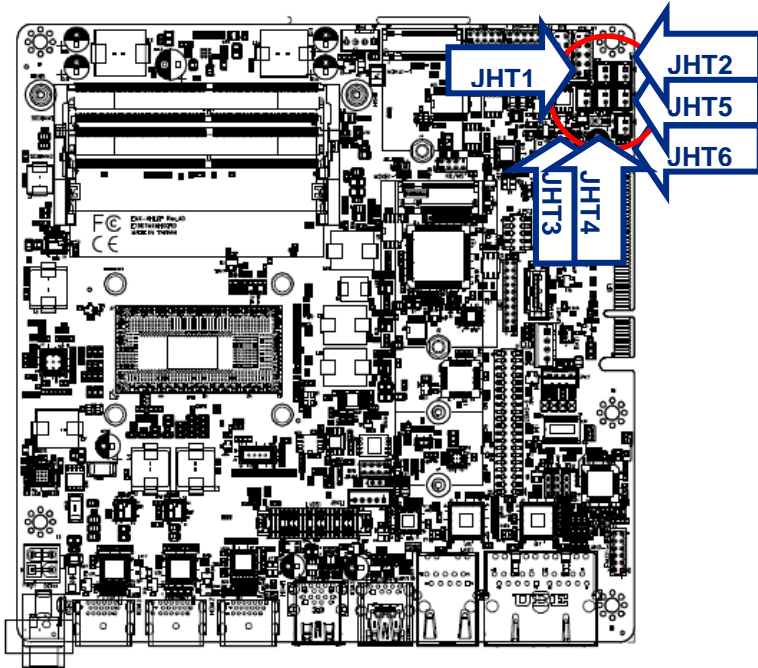

PIN	Signal
1	+12V
2	GND

2.3.30 LED Indicator for Heater (JHT_LED1)

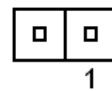
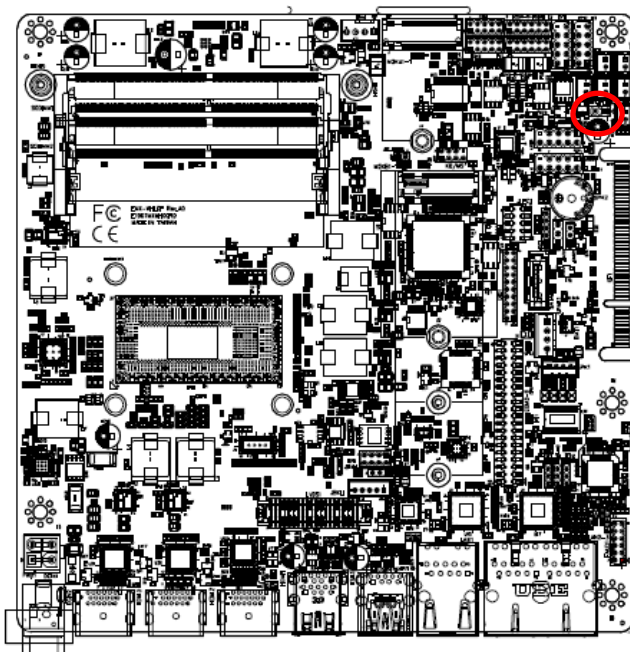

PIN	Signal
1	+12V
2	GND

2.3.31 Gold Finger (GF)

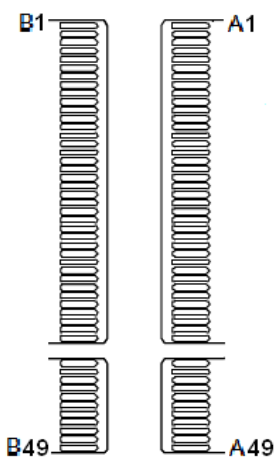
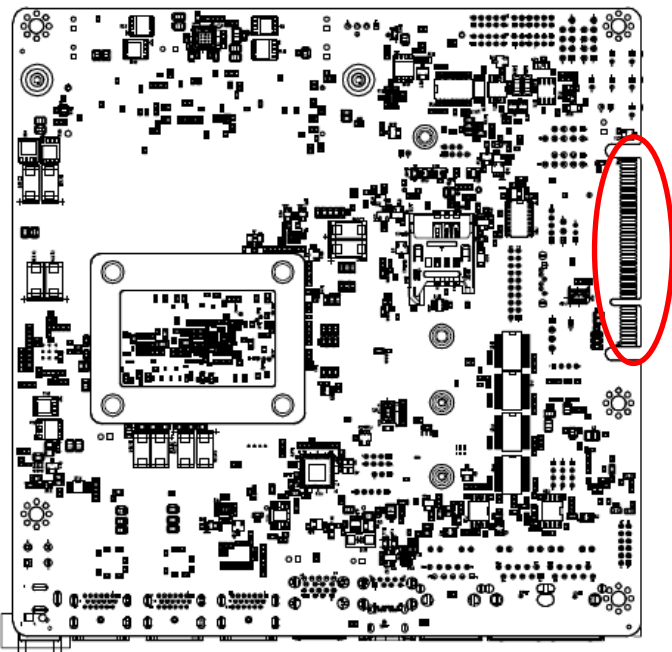
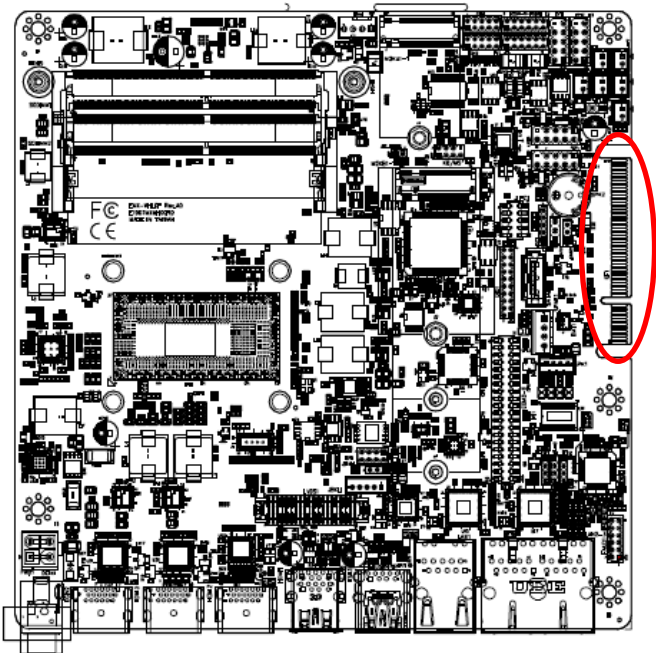

Signal	PIN	PIN	Signal
+12V	B1	A1	+12V
+12V	B2	A2	+12V
+12V	B3	A3	+12V
GND	B4	A4	GND
SMB_CLK_S	B5	A5	EN_V5S-V3.3S
SMB_DATA_S	B6	A6	GF_PWR_OK
GND	B7	A7	GF_CKL_REQ#
NC	B8	A8	GF_SATA1_DEVSLP
GF_PWR_BTN_EC#	B9	A9	+5V
+3.3V	B10	A10	+5V
GF_PWAKE#	B11	A11	RST_GF#
	KEY		
USB_PWR_EN_GF	B12	A12	GND
GND	B13	A13	CLK_GF_P5
PCIE_TXP13	B14	A14	CLK_GF_N5
PCIE_TXN13	B15	A15	GND
GND	B16	A16	PCIE_RXP13
NC	B17	A17	PCIE_RXN13
GND	B18	A18	GND
PCIE_TXP14	B19	A19	NC
PCIE_TXN14	B20	A20	GND
GND	B21	A21	PCIE_RXP14
GND	B22	A22	PCIE_RXN14
PCIE_TXP15	B23	A23	GND
PCIE_TXN15	B24	A24	GND
GND	B25	A25	PCIE_RXP15

EMX-WHLGP User's Manual

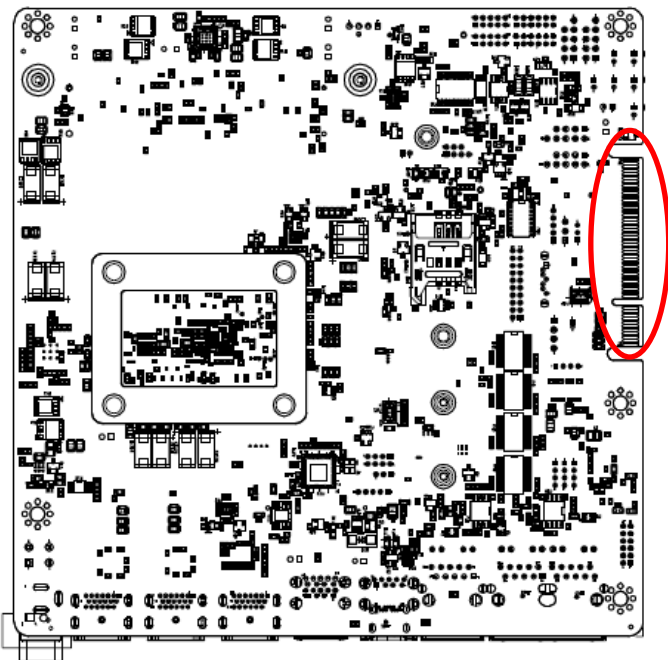
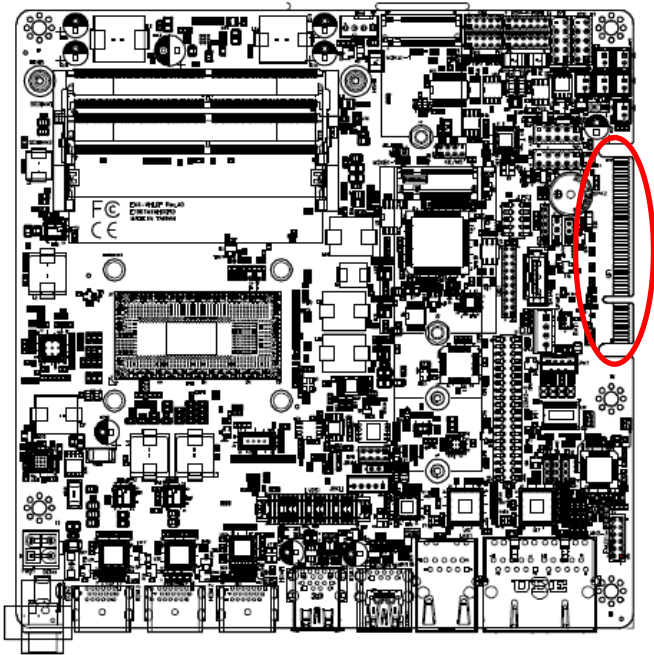

Signal	PIN	PIN	Signal
GND	B26	A26	PCIE_RXN15
PCIE_TXP16	B27	A27	GND
PCIE_TXN16	B28	A28	GND
GND	B29	A29	PCIE_RXP16
NC	B30	A30	PCIE_RXN16
NC	B31	A31	GND
GND	B32	A32	NC
USB_PP7	B33	A33	GF_USB_OC#
USB_PN7	B34	A34	GND
GND	B35	A35	NC
GND	B36	A36	NC
SATA_TXP_1_GF_L	B37	A37	GND
SATA_TXN_1_GF_L	B38	A38	GND
GND	B39	A39	SATA_RXN_1_GF_L
GND	B40	A40	SATA_RXP_1_GF_L
PCIE_GF_TXP9	B41	A41	GND
PCIE_GF_TXN9	B42	A42	GND
GND	B43	A43	PCIE_GF_RXP9
GND	B44	A44	PCIE_GF_RXN9
NC	B45	A45	GND
NC	B46	A46	GND
GND	B47	A47	NC
NC	B48	A48	NC
GND	B49	A49	GND

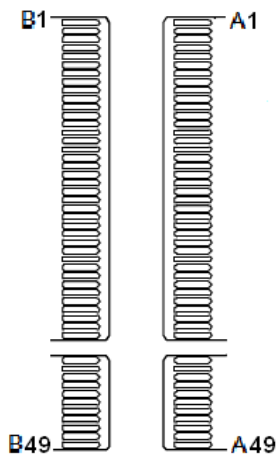

2.3.32 Power connector (PWR1)

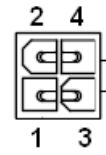
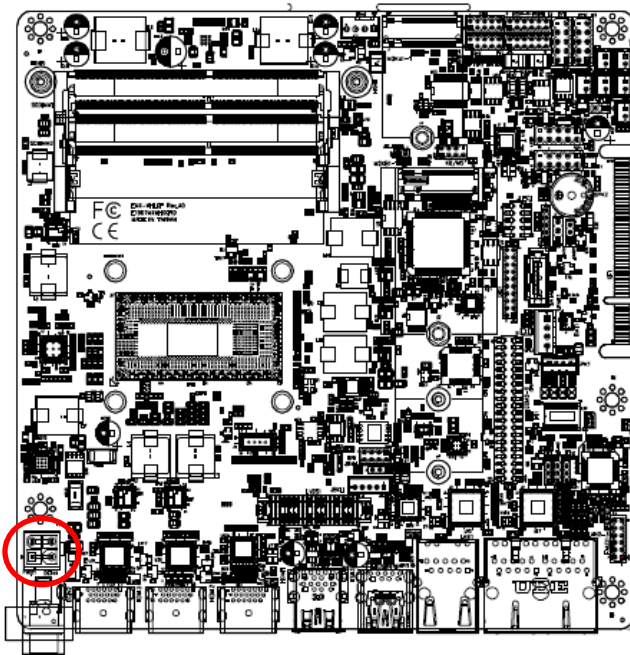

Signal	PIN	PIN	Signal
GND	2	4	+VIN
GND	1	3	+VIN

Note: VIN = 12~24V

3. BIOS Setup

3.1 Introduction

The BIOS setup program allows users to modify the basic system configuration. In this following chapter will describe how to access the BIOS setup program and the configuration options that may be changed.

3.2 Starting Setup

The AMI BIOS™ is immediately activated when you first power on the computer. The BIOS reads the system information contained in the NVRAM and begins the process of checking out the system and configuring it. When it finishes, the BIOS will seek an operating system on one of the disks and then launch and turn control over to the operating system.

While the BIOS is in control, the Setup program can be activated in one of two ways:

By pressing or <F2> immediately after switching the system on, or

By pressing the or <F2> key when the following message appears briefly at the left-top of the screen during the POST (Power On Self Test).

Press or <F2> to enter SETUP

If the message disappears before you respond and you still wish to enter Setup, restart the system to try again by turning it OFF then ON or pressing the "RESET" button on the system case. You may also restart by simultaneously pressing <Ctrl>, <Alt>, and <Delete> keys. If you do not press the keys at the correct time and the system does not boot, an error message will be displayed and you will again be asked to.

Press F1 to Continue, DEL to enter SETUP

3.3 Using Setup

In general, you use the arrow keys to highlight items, press <Enter> to select, use the PageUp and PageDown keys to change entries, press <F1> for help and press <Esc> to quit. The following table provides more detail about how to navigate in the Setup program using the keyboard.

Button	Description
↑↓→←	Move
Enter	Select
+/-	Value
Esc	Exit
F1	General Help
F2	Previous Values
F3	Optimized Defaults
F4	Save & Exit Setup
<K>	Scroll help area upwards
<M>	Scroll help area downwards

- **Navigating Through The Menu Bar**

Use the left and right arrow keys to choose the menu you want to be in.



Note: Some of the navigation keys differ from one screen to another.

- **To Display a Sub Menu**

Use the arrow keys to move the cursor to the sub menu you want. Then press <Enter>. A “>” pointer marks all sub menus.

3.4 Getting Help

Press F1 to pop up a small help window that describes the appropriate keys to use and the possible selections for the highlighted item. To exit the Help Window press <Esc> or <Enter> key.

3.5 In Case of Problems

If, after making and saving system changes with Setup, you discover that your computer no longer is able to boot, the AMI BIOS supports an override to the NVRAM settings which resets your system to its defaults.

The best advice is to only alter settings which you thoroughly understand. To this end, we strongly recommend that you avoid making any changes to the chipset defaults. These defaults have been carefully chosen by both BIOS Vendor and your systems manufacturer to provide the absolute maximum performance and reliability. Even a seemingly small change to the chipset setup has the potential for causing you to use the override.

3.6 BIOS setup

Once you enter the Aptio Setup Utility, the Main Menu will appear on the screen. The Main Menu allows you to select from several setup functions and exit choices. Use the arrow keys to select among the items and press <Enter> to accept and enter the sub-menu.

3.6.1 Main Menu

This section allows you to record some basic hardware configurations in your computer and set the system clock.

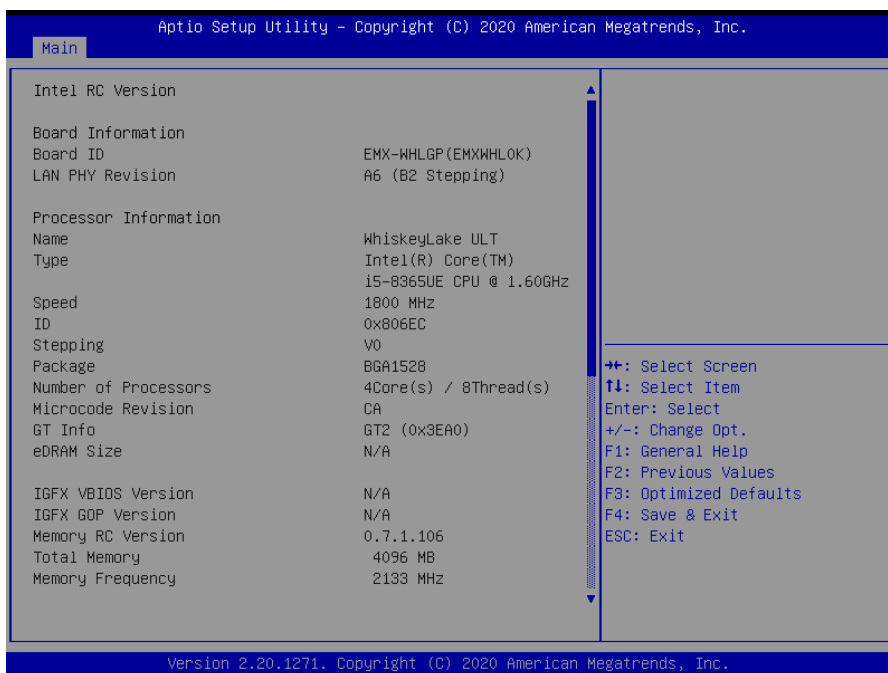
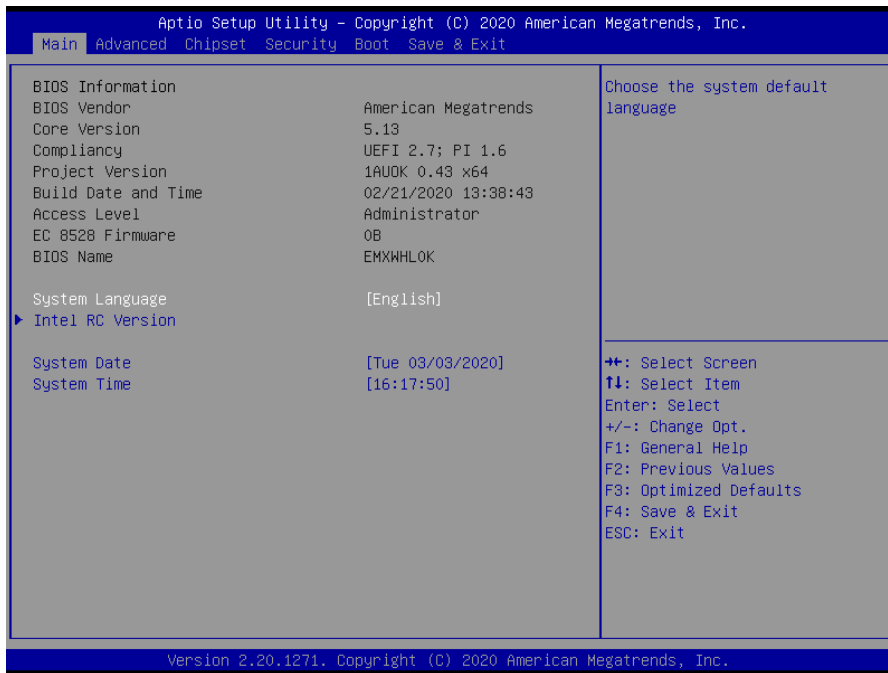

3.6.1.1 System Language

This option allows choosing the system default language.

3.6.1.2 System Date

Use the system date option to set the system date. Manually enter the day, month and year.

3.6.1.3 System Time

Use the system time option to set the system time. Manually enter the hours, minutes and seconds.



Note: The BIOS setup screens shown in this chapter are for reference purposes only, and may not exactly match what you see on your screen.

Visit the Avalue website (www.avalue.com.tw) to download the latest product and BIOS information.

3.6.2 Advanced Menu

This section allows you to configure your CPU and other system devices for basic operation through the following sub-menus.

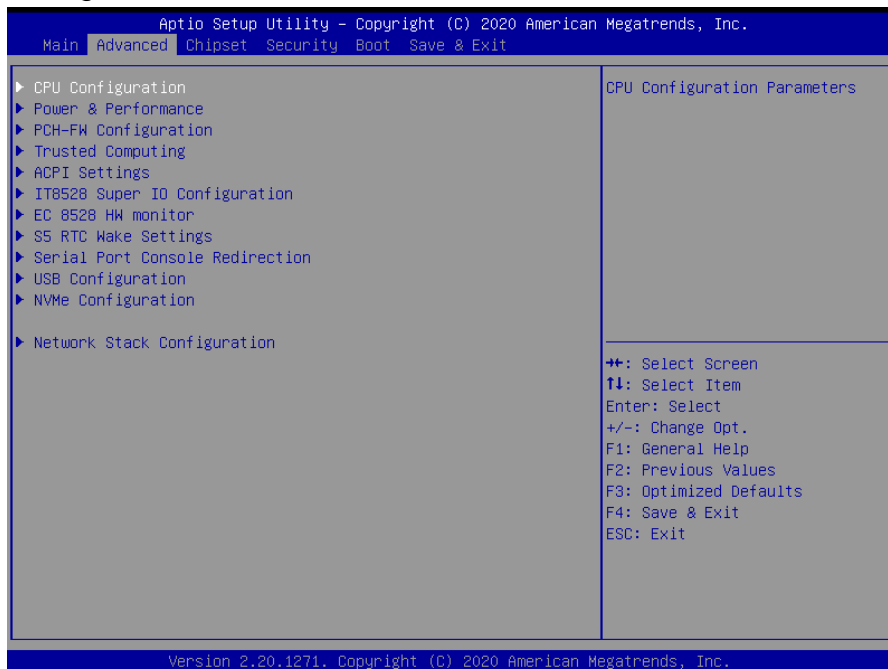

EMX-WHLGP User's Manual

3.6.2.1 CPU Configuration

Use the CPU configuration menu to view detailed CPU specification and configure the CPU.



Item	Options	Description
Intel (VMX) Virtualization Technology	Disabled, Enabled[Default]	When enabled, a VMM can utilize the additional hardware capabilities provided by Vanderpool Technology.
Active Processor Cores	All[Default] 1 2 3 4	Number of cores to enable in each processor package.

3.6.2.2 Power & Performance



3.6.2.2.1 CPU - Power Management Control

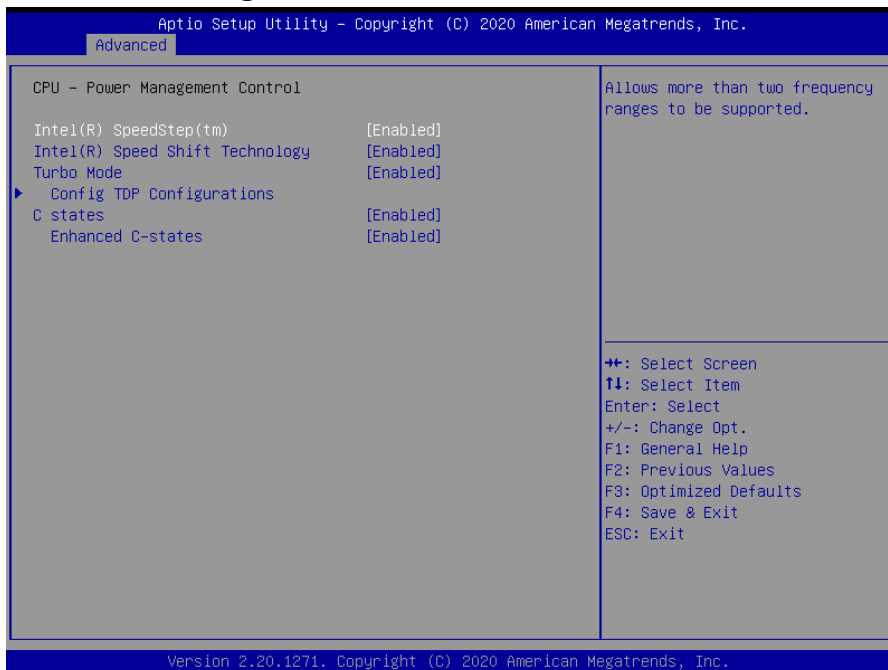

Item	Options	Description
Intel(R) SpeedStep(tm)	Disabled, Enabled[Default]	Allows more than two frequency ranges to be supported.
Intel(R) Speed Shift Technology	Disabled, Enabled[Default]	Enable/Disable Intel(R) Speed Shift Technology support. Enabling will expose the CPPC v2 interface to allow for hardware controlled P-states.

EMX-WHLGP User's Manual

Turbo Mode	Disabled, Enabled[Default]	Enable/Disable processor Turbo Mode (requires Intel Speed Step or Intel Speed Shift to be available and enabled).
C states	Disabled, Enabled[Default]	Enable/Disable CPU Power Management. Allows CPU to go to C states when it's not 100% utilized.
Enhanced C-states	Disabled, Enabled[Default]	Enable/Disable C1E. When enabled, CPU will switch to minimum speed when all cores enter C-State.

3.6.2.2.1.1 Config TDP Configurations

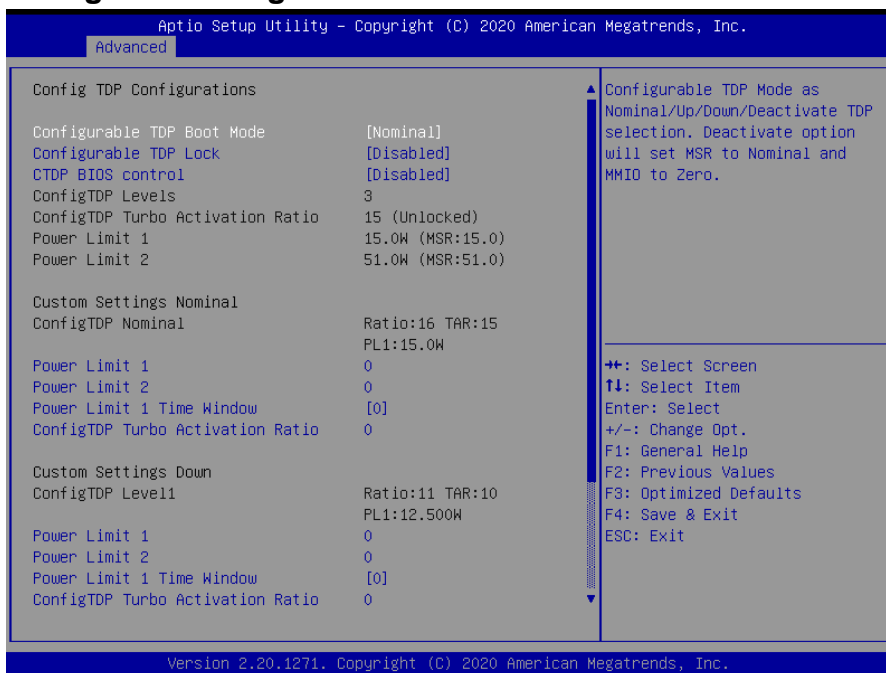

Item	Options	Description
Configurable TDP Boot Mode	Nominal[Default] Up Down Deactivate	Configurable TDP Mode as Nominal/Up/Down/Deactivate TDP selection. Deactivate option will set MSR to Nominal and MMIO to Zero.
Configurable TDP Lock	Enabled, Disabled[Default]	Configurable TDP Mode Lock sets the Lock bits on TURBO_ACTIVATION_RATIO and CONFIG_TDP_CONTROL. Note: When CTDTP Lock is enabled Custom ConfigTDP Count will be forced to 1 and Custom ConfigTDP Boot Index will be forced to 0.
CTDTP BIOS control	Enabled, Disabled[Default]	Enables CTDTP control via runtime ACPI BIOS methods. This "BIOS only" feature does not require EC or driver support.
Power Limit 1	0	Power Limit 1 in Milli Watts. BIOS will round to the nearest 1/8W when programming. 0 = no custom override. For 12.50W, enter 12500. Overclocking

		SKU: Value must be between Max and Min Power Limits (specified by PACKAGE_POWER_SKU_MSR). Other SKUs: This value must be between Min Power
Power Limit 2	0	Power Limit 2 value in Milli Watts. BIOS will round to the nearest 1/8W when programming. 0 = no custom override. For 12.50W, enter 12500. Processor applies control policies such that the package power does not exceed this limit.
Power Limit 1 Time Window	<p>0[Default]</p> <p>1</p> <p>2</p> <p>3</p> <p>4</p> <p>5</p> <p>6</p> <p>7</p> <p>8</p> <p>10</p> <p>12</p> <p>14</p> <p>16</p> <p>20</p> <p>24</p> <p>28</p> <p>32</p> <p>40</p> <p>48</p> <p>56</p> <p>64</p> <p>80</p> <p>96</p> <p>112</p> <p>128</p>	Power Limit 1 Time Window value in seconds. The value may vary from 0 to 128. 0 = use default value (28 sec). Defines time window which TDP value should be maintained.
ConfigTDP Turbo Activation Ratio	0	Custom value for Turbo Activation Ratio. Needs to be configured with valid values from LFM to Max Turbo. 0 means don't use custom value.

3.6.2.2.2 GT - Power Management Control



Item	Options	Description
RC6(Render Standby)	Disabled, Enabled[Default]	Check to enable render standby support.
Maximum GT frequency	Default Max Frequency[Default] 100Mhz 150Mhz 200Mhz 250Mhz 300Mhz 350Mhz 400Mhz 450Mhz 500Mhz 550Mhz 600Mhz 650Mhz 700Mhz 750Mhz 800Mhz 850Mhz 900Mhz 950Mhz 1000Mhz 1050Mhz 1100Mhz 1150Mhz 1200Mhz	Auto Updated

Disable Turbo GT frequency	Enabled, Disabled[Default]	Enabled: Disables Turbo GT frequency. Disabled GT frequency is not limited
-----------------------------------	-------------------------------	-------------------------------------------------------------------------------

3.6.2.3 PCH-FW Configuration

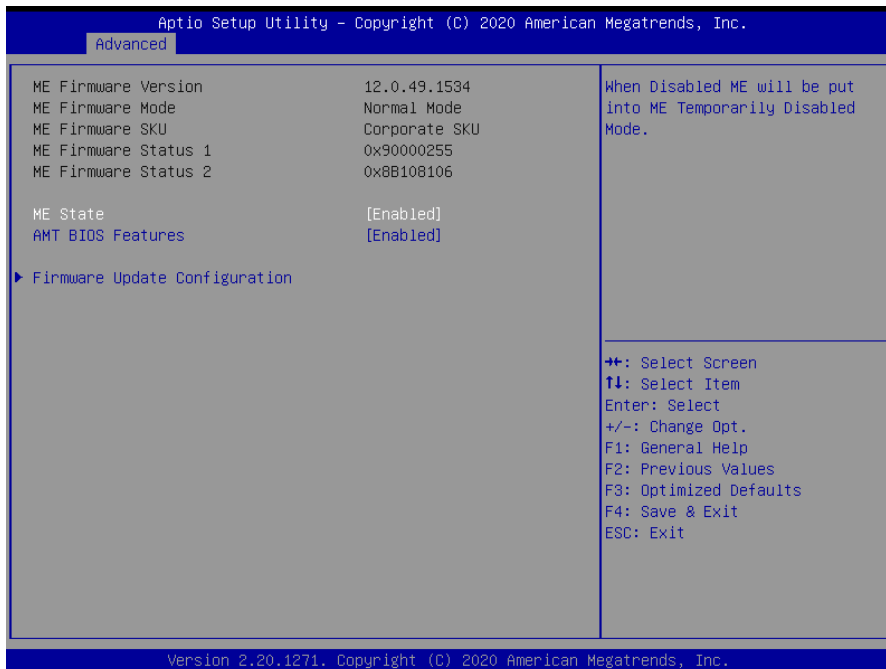

Item	Options	Description
ME State	Disabled, Enabled[Default]	When Disabled ME will be put into ME Temporarily Disabled Mode.
AMT BIOS Features	Disabled, Enabled[Default]	When disabled AMT BIOS Features are no longer supported and user is no longer able to access MEBx Setup. Note: This option does not disable Manageability Features in FW.

EMX-WHLGP User's Manual

3.6.2.3.1 Firmware Update Configuration

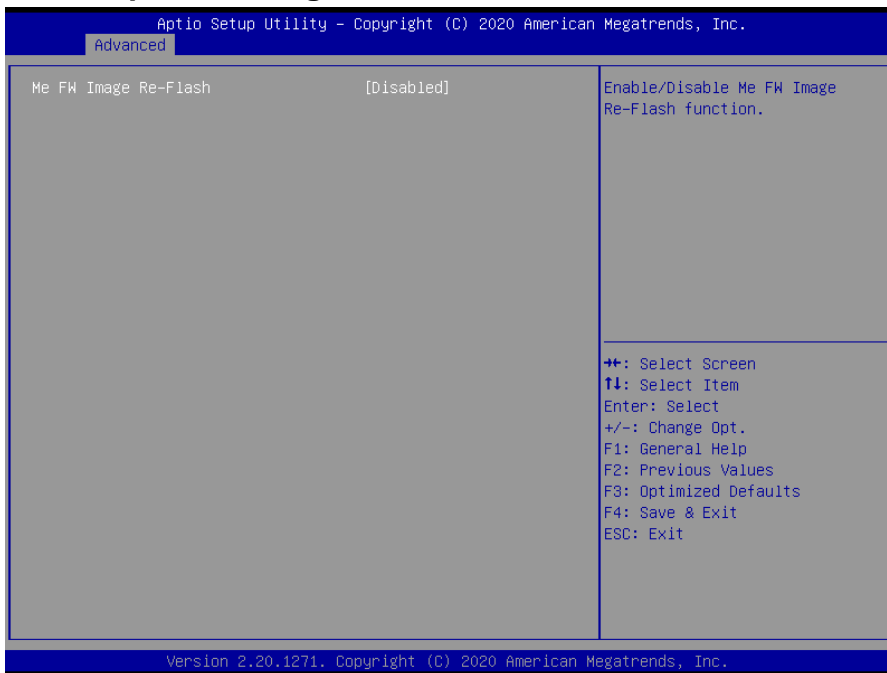

Item	Options	Description
Me FW Image Re-Flash	Disabled[Default], Enabled	Enable/Disable Me FW Image Re-Flash function.

3.6.2.4 Trusted Computing

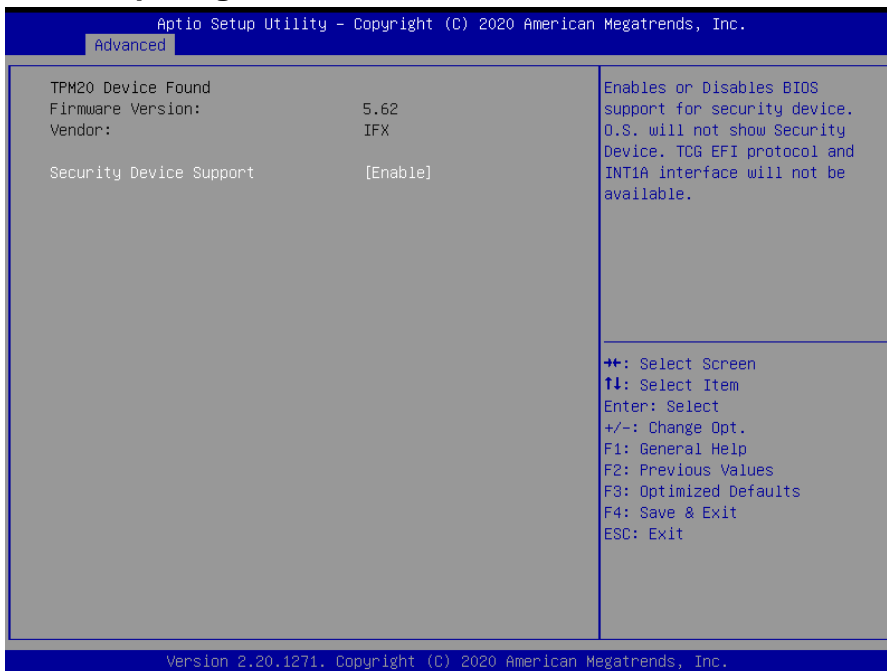

Item	Options	Description
Security Device Support	Disabled, Enabled[Default]	Enable or Disable BIOS support for security device. O.S. will not show Security Device. TCG EFI protocol and INT1A interface will not be available.

3.6.2.5 ACPI Settings



Item	Options	Description
Enable Hibernation	Disabled Enabled[Default],	Enables or Disables System ability to Hibernate (OS/S4 Sleep State). This option may be not effective with some operating systems.
ACPI Sleep State	Suspend Disabled, S3 (Suspend to RAM)[Default]	Select the highest ACPI sleep state the system will enter when the SUSPEND button is pressed.

EMX-WHLGP User's Manual

3.6.2.6 IT8528 Super IO Configuration

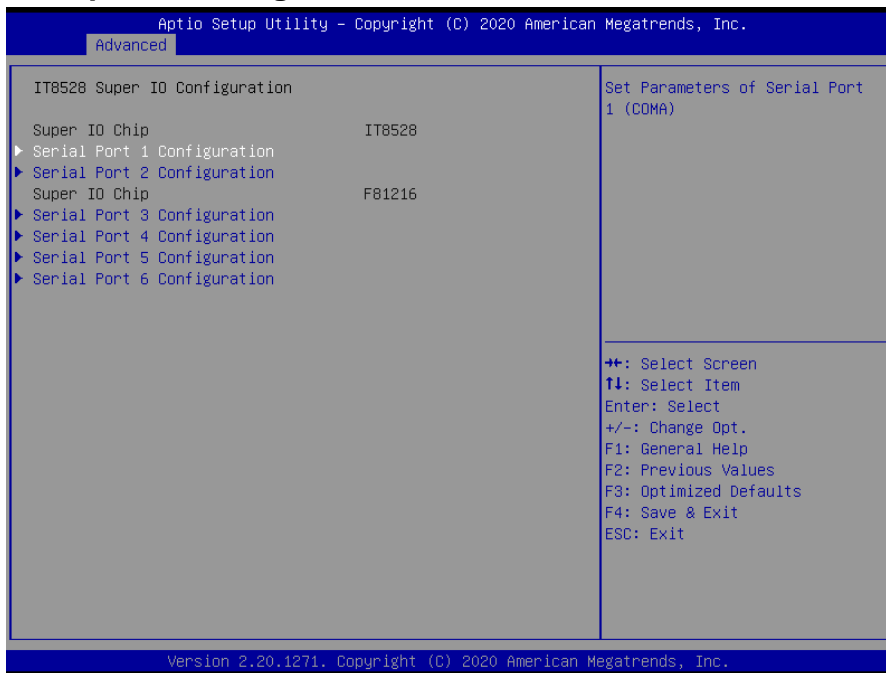

Item	Description
Serial Port 1 Configuration	Set Parameters of Serial Port 1 (COMA).
Serial Port 2 Configuration	Set Parameters of Serial Port 2 (COMB).
Serial Port 3 Configuration	Set Parameters of Serial Port 3 (COMC).
Serial Port 4 Configuration	Set Parameters of Serial Port 4 (COMD).
Serial Port 5 Configuration	Set Parameters of Serial Port 5 (COME).
Serial Port 6 Configuration	Set Parameters of Serial Port 6 (COMF).

3.6.2.6.1 Serial Port 1 Configuration

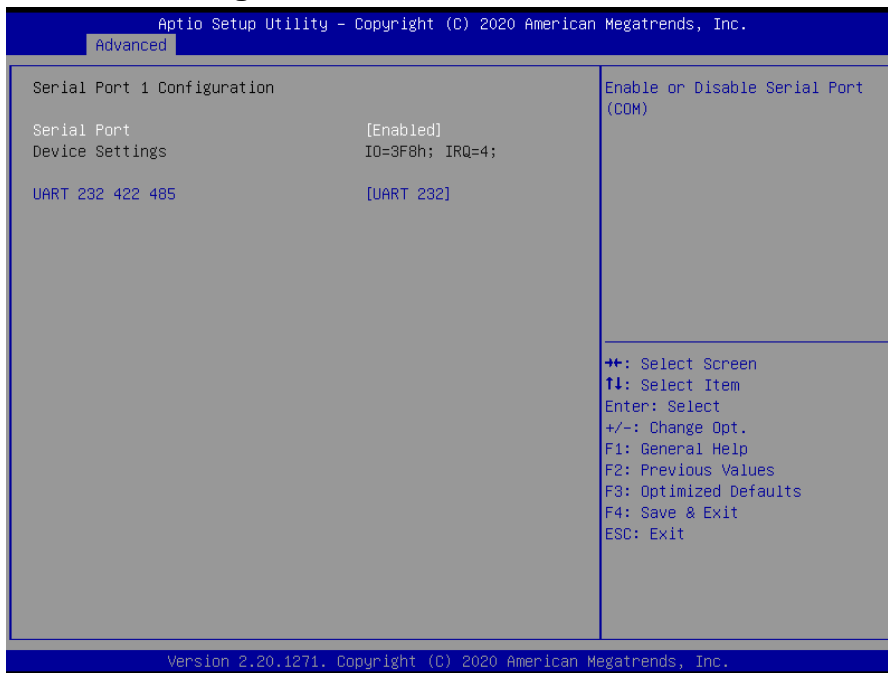

Item	Option	Description
Serial Port	Disabled Enabled[Default],	Enable or Disable Serial Port (COM).
UART 232 422 485	UART 232[Default], UART 422, UART 485	Change the Serial Port as RS232/422/485.

3.6.2.6.2 Serial Port 2 Configuration

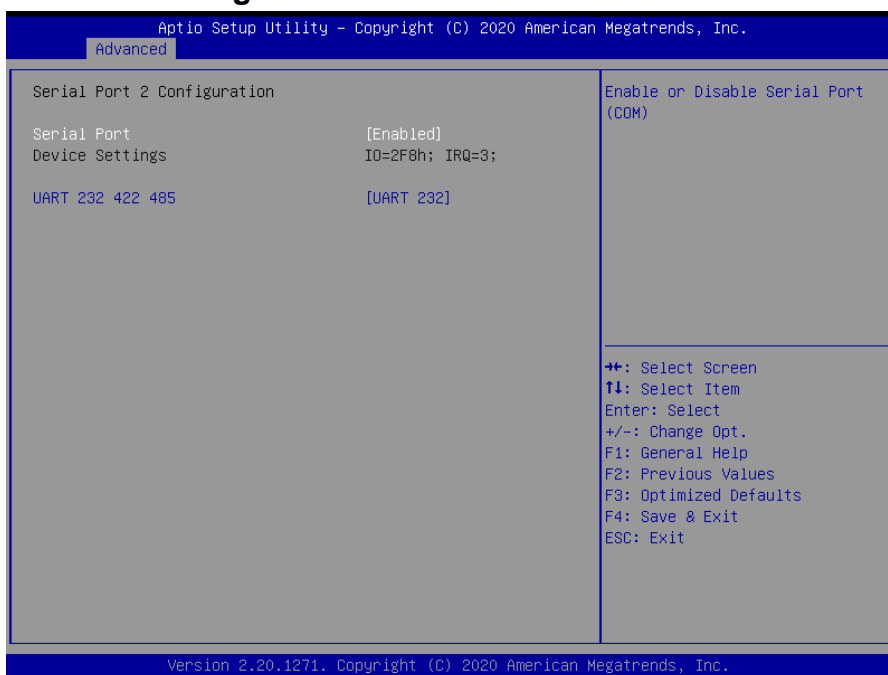

EMX-WHLGP User's Manual

Item	Option	Description
Serial Port	Disabled Enabled[Default],	Enable or Disable Serial Port (COM).
UART 232 422 485	UART 232[Default], UART 422, UART 485	Change the Serial Port as RS232/422/485.

3.6.2.6.3 Serial Port 3 Configuration

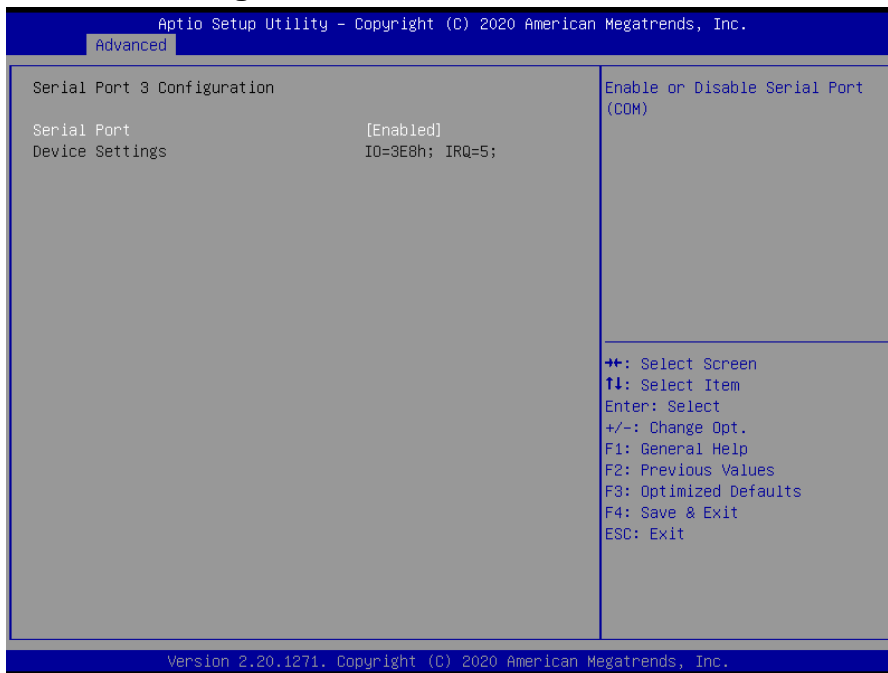

Item	Option	Description
Serial Port	Disabled Enabled[Default],	Enable or Disable Serial Port (COM).

3.6.2.6.4 Serial Port 4 Configuration



Item	Option	Description
Serial Port	Disabled Enabled[Default],	Enable or Disable Serial Port (COM).

3.6.2.6.5 Serial Port 5 Configuration

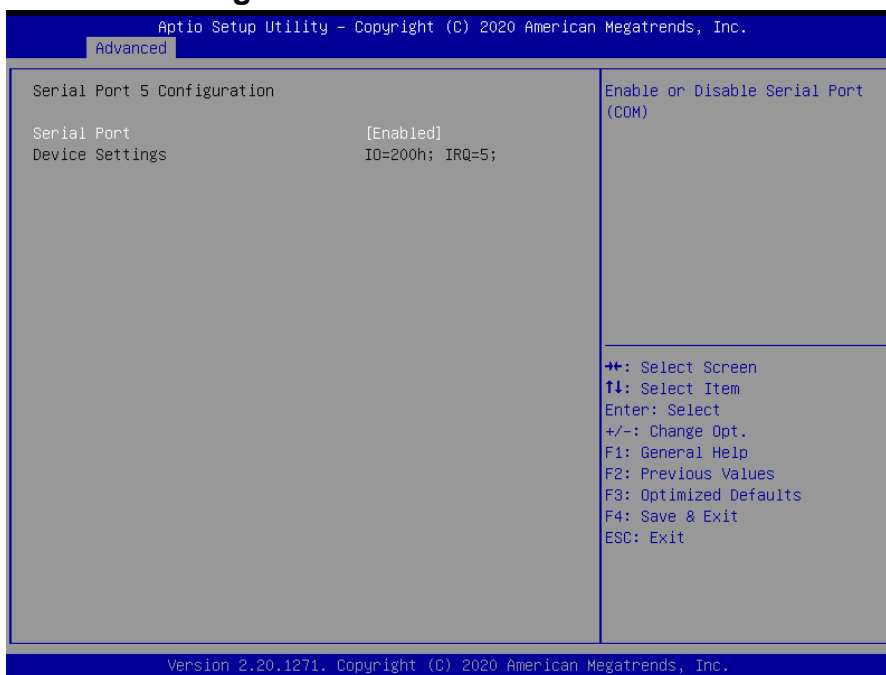

Item	Option	Description
Serial Port	Disabled Enabled[Default],	Enable or Disable Serial Port (COM).

3.6.2.6.6 Serial Port 6 Configuration

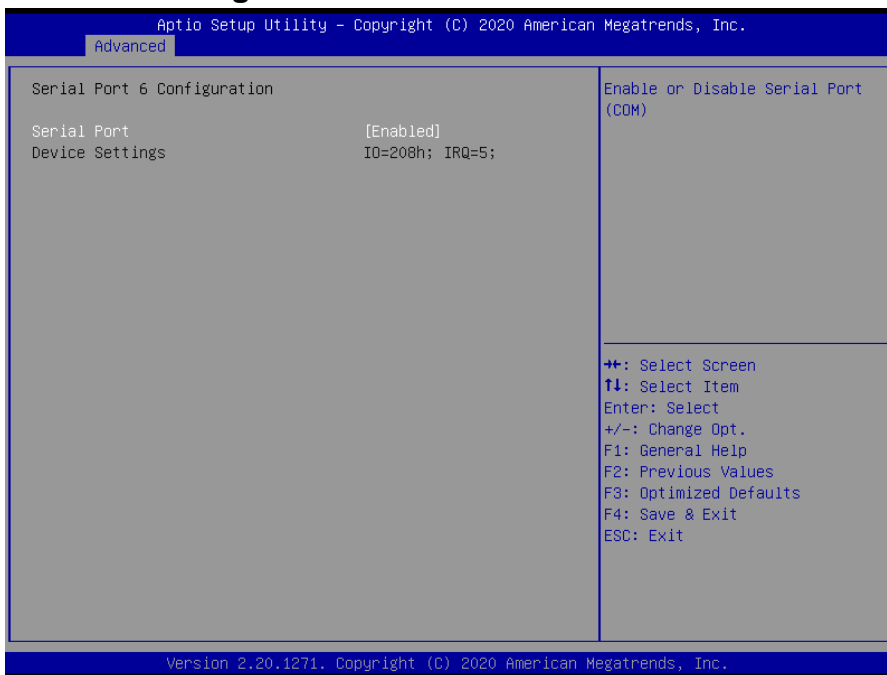

Item	Option	Description
Serial Port	Disabled Enabled[Default],	Enable or Disable Serial Port (COM).

3.6.2.7 EC 8528 HW monitor

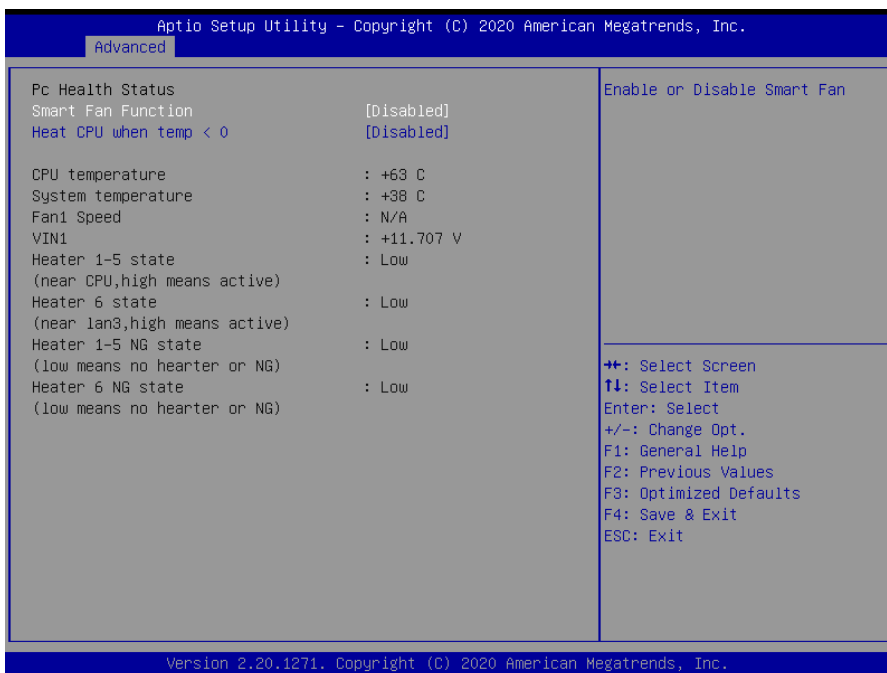

Item	Options	Description
Smart Fan Function	Disabled[Default], Enabled	Enabled or Disable Smart Fan
Heat CPU when temp < 0	Disabled[Default], Enabled	Turn on heater when CPU temperature below 0degree C before system boot up.

3.6.2.7.1 EC 8528 HW monitor-note

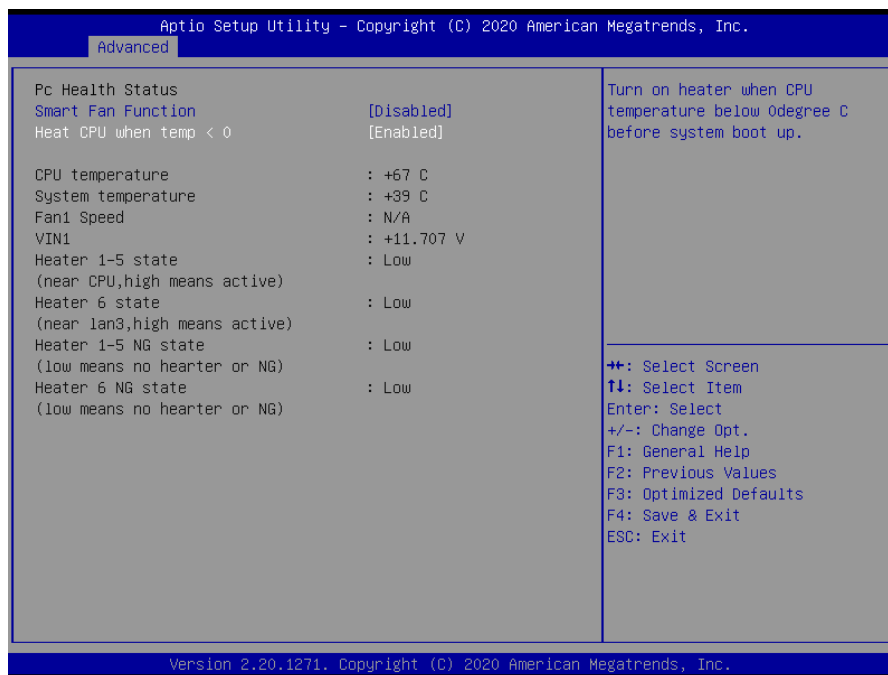

Item	Options	Description
Smart Fan Function	Disabled[Default], Enabled	Enabled or Disable Smart Fan
Heat CPU when temp < 0	For finished product package with heatsink and heater attached, item Heat CPU when temp < 0 would be enabled as default.	

EMX-WHLGP User's Manual

3.6.2.8 S5 RTC Wake Settings

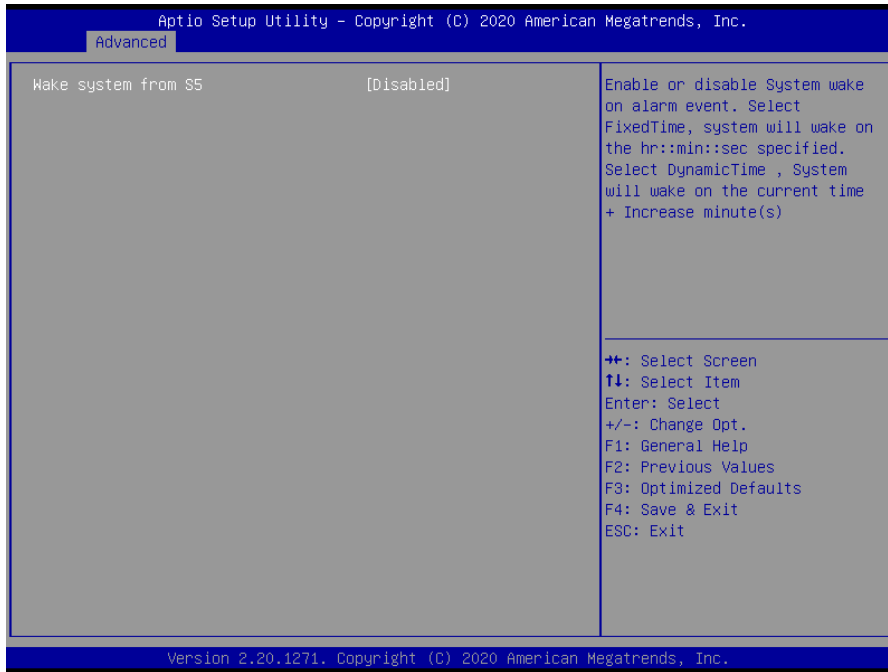

Item	Options	Description
Wake system from S5	Disabled[Default], Fixed Time Dynamic Time	Enabled or disable System wake on alarm event. Select Fixed Time, system will wake on the hr::min::sec specified. Select Dynamic Time, System will wake on the current time + Increase minute(s)

3.6.2.9 Serial Port Console Redirection

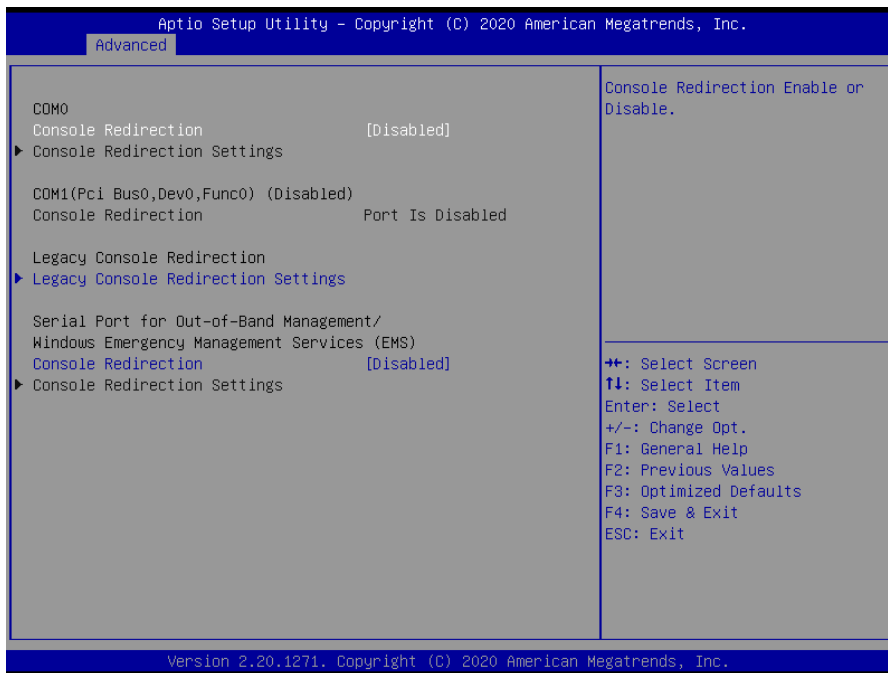

Item	Option	Description
Console Redirection	Disabled[Default], Enabled	Console Redirection Enabled or Disable.

3.6.2.9.1 Legacy Serial Redirection Port

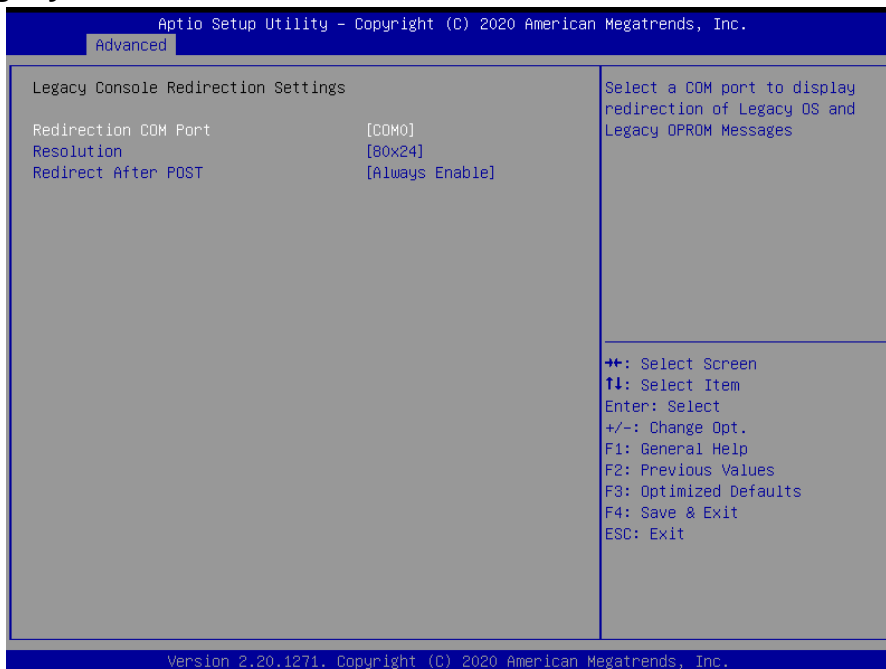

Item	Option	Description
Redirection COM Port	COM0	Select a COM port to display redirection of Legacy OS and Legacy OPROM Messages
Resolution	80x24[Default], 80x25	On Legacy Os, the Number of Rows and Columns supported redirection
Redirect After POST	Always Enable[Default], BootLoader	When Bootloader is selected, then Legacy Console Redirection is disabled before booting to legacy OS. When Always Enable is selected, then Legacy Console Redirection is enabled for legacy OS. Default setting for this option is set to Always Enable.

3.6.2.10 USB Configuration

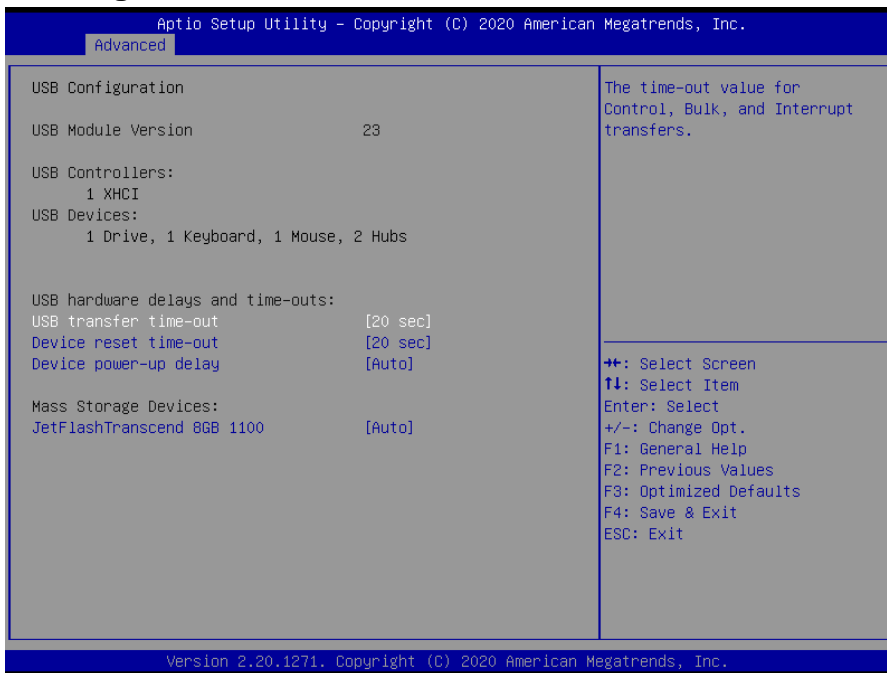

Item	Options	Description
USB transfer time-out	1 sec 5 sec 10 sec 20 sec [Default]	The time-out value for Control, Bulk, and Interrupt transfers.
Device reset time-out	10 sec 20 sec [Default] 30 sec 40 sec	USB mass storage device Start Unit command time-out.
Device power-up delay	Auto [Default] Manual	Maximum time the device will take before it properly reports itself to the Host Controller. 'Auto' uses default value: for a Root port it is 100ms, for a Hub port the delay is taken form Hub descriptor.
JetFlashTranscend 8GB 1100	Auto [Default] Floppy Forced FDD Hard Disk CD-ROM	Mass storage device emulation type. 'AUTO' enumerates devices according to their media format. Optical drives are emulated as 'CDROM', drive with no media will be emulated according to a drive type.

3.6.2.11 NVMe controller and Drive information

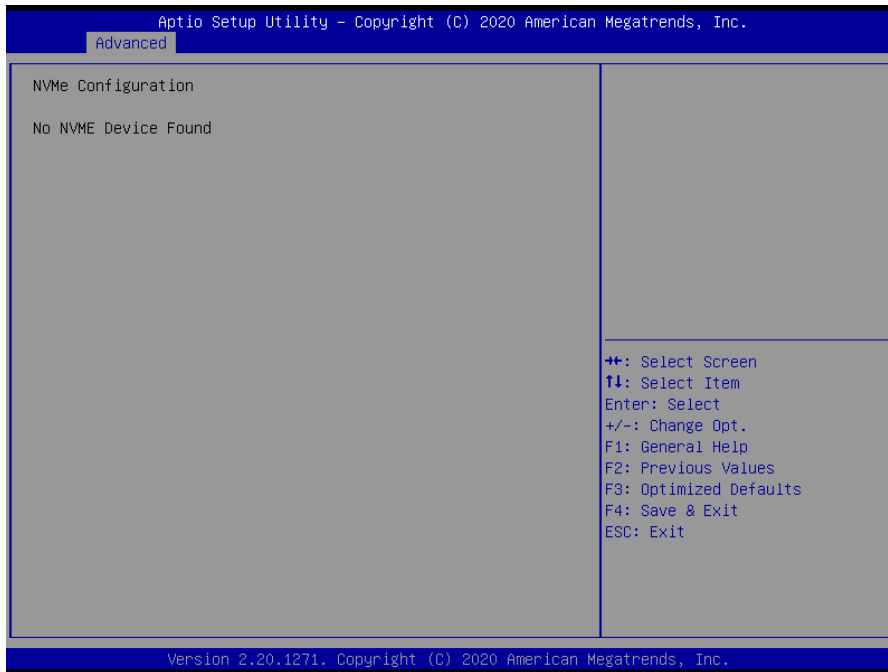

3.6.2.12 Network Stack Configuration



EMX-WHLGP User's Manual

3.6.3 Chipset

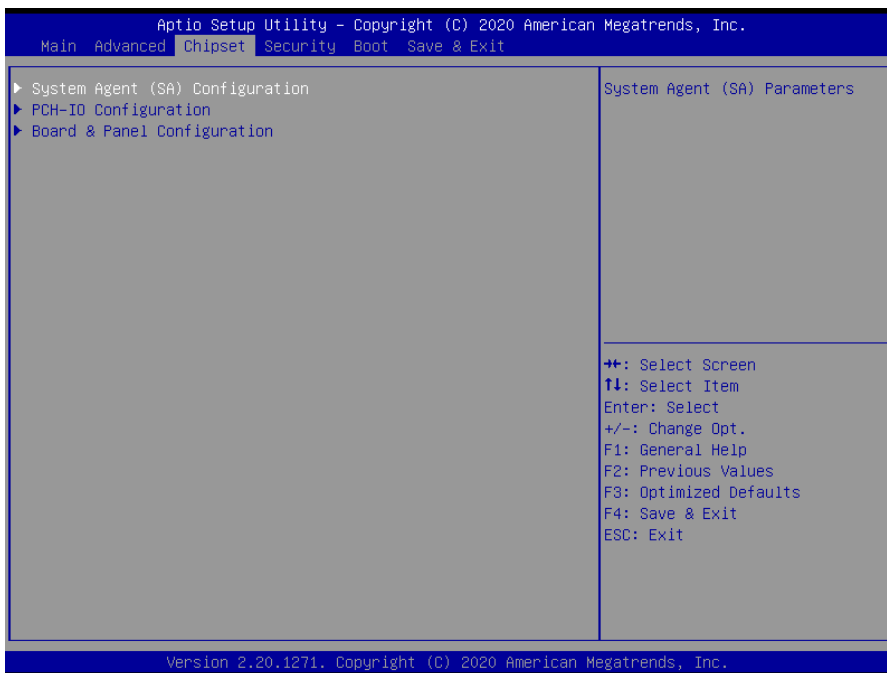

3.6.3.1 System Agent (SA) Configuration



Item	Option	Description
VT-d	Disabled Enabled[Default]	VT-d capability.

3.6.3.1.1 Memory Configuration

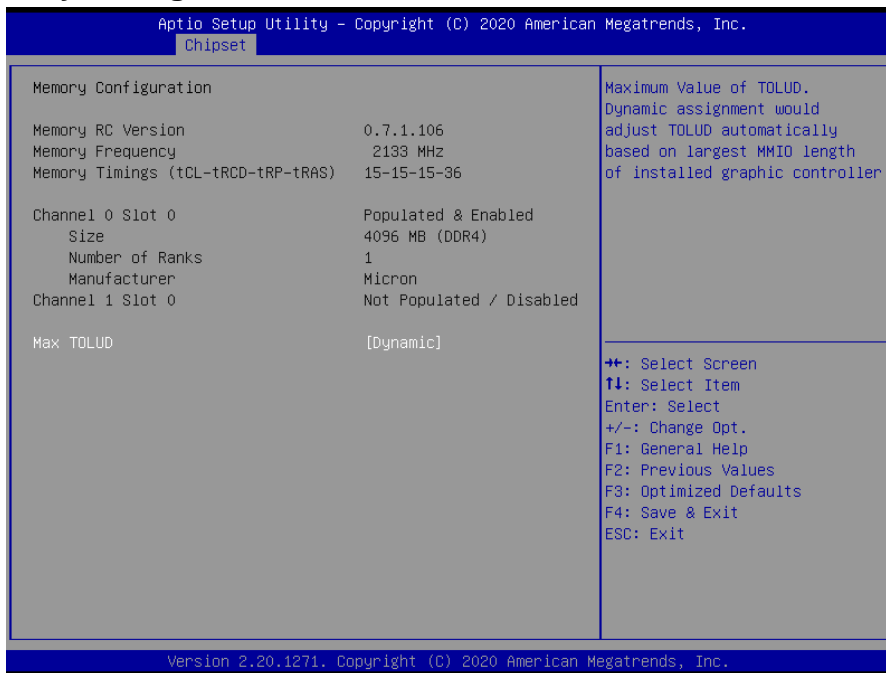

Item	Option	Description
Max TOLUD	Dynamic 1GB[Default] 1GB 1.25GB 1.5GB 1.75 GB 2 GB 2.25 GB 2.5 GB 2.75 GB 3 GB	Maximum Value of TOLUD. Dynamic assignment would adjust TOLUD automatically based on largest MMIO length of installed graphic controller

3.6.3.1.2 Graphics Configuration

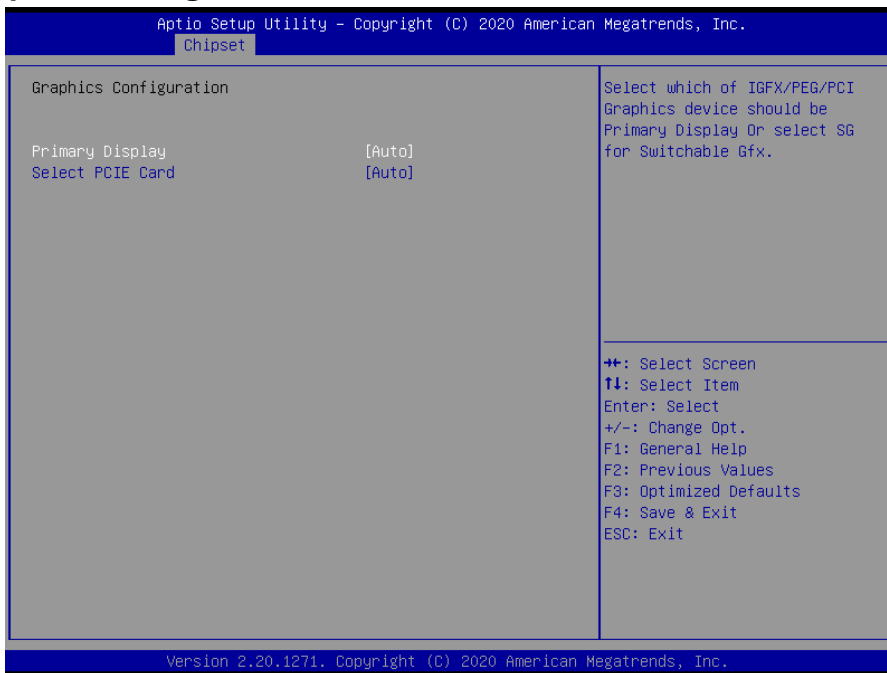

Item	Option	Description
Primary Display	Auto[Default] IGFX PEG PCI SG	Select which of IGFX/PEG/PCI Graphics device should be Primary Display Or select SG for Switchable Gfx.
Select PCIE Card	Auto[Default] Elk Creek 4 PEG Eval	Select the card used on the platform Auto : Skip GPIO based Power Enable to dGPU Elk Creek 4: DGPU Power Enable = ActiveLow PEG Eval : DGPU Power Enable = ActiveHigh

3.6.3.2 PCH-IO Configuration



Item	Option	Description
PCH LAN(I219) Controller	Enabled[Default] Disabled	Enable/Disable onboard NIC.

3.6.3.2.1 PCI Express Configuration

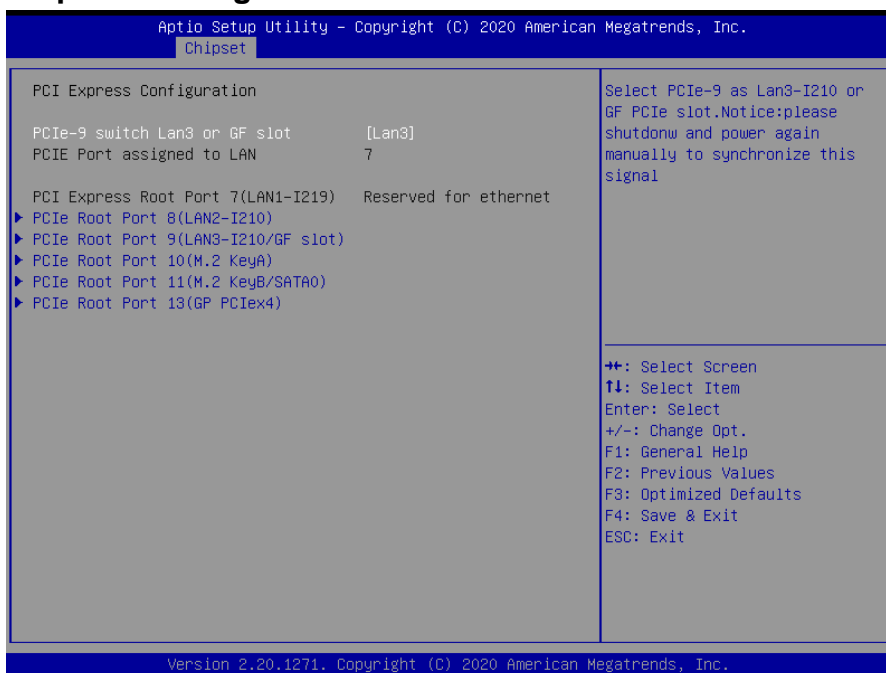

Item	Option	Description
PCIe-9 switch Lan3 or GF slot	Lan3 [Default]	Select PCIe-9 as Lan3-1210 or GF PCIe

EMX-WHLGP User's Manual

	GF slot	slot Notice:please shutdown and power again manually to synchronize this signal
--	---------	---------------------------------------------------------------------------------

3.6.3.2.1.1 PCIe Root Port 8(LAN2-I210)

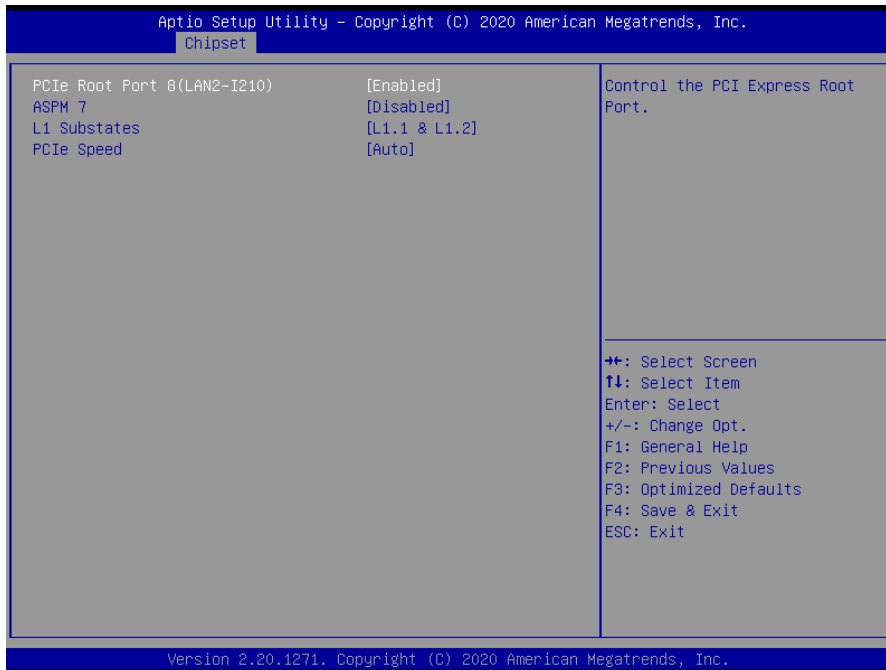

Item	Option	Description
PCIe Root Port 8(LAN2-I210)	Disabled Enabled[Default],	Control the PCI Express Root Port.
ASPM 7	Disabled[Default] L0s L1 L0sL1 Auto,	Set the ASPM Level: Force L0s - Force all links to L0s State AUTO - BIOS auto configure DISABLE - Disables ASPM.
L1 Substates	Disabled L1.1 L1.1 & L1.2[Default],	PCI Express L1 Substates settings.
PCIe Speed	Auto[Default] Gen1 Gen2 Gen3	Configure PCIe speed.

3.6.3.2.1.2 PCIe Root Port 9(LAN3-I210/GF slot)

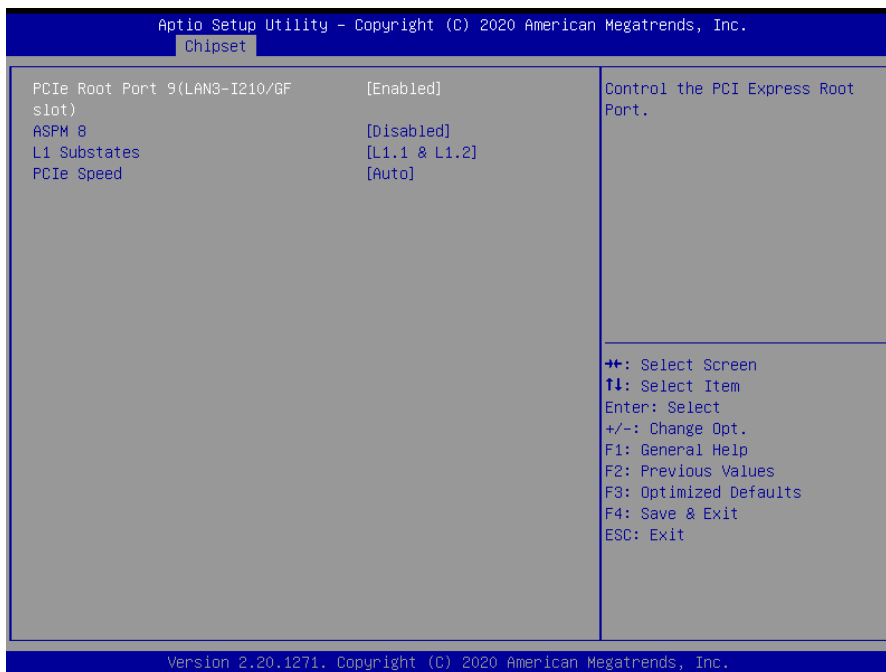

Item	Option	Description
PCIe Root Port 9 (LAN3-I210/GF slot)	Disabled Enabled[Default],	Control the PCI Express Root Port.
ASPM 8	Disabled[Default] L0s L1 L0sL1 Auto,	Set the ASPM Level: Force L0s - Force all links to L0s State AUTO - BIOS auto configure DISABLE - Disables ASPM.
L1 Substates	Disabled L1.1 L1.1 & L1.2[Default],	PCI Express L1 Substates settings.
PCIe Speed	Auto[Default] Gen1 Gen2 Gen3	Configure PCIe speed.

3.6.3.2.1.3 PCIe Root Port 10(M.2 KeyA)

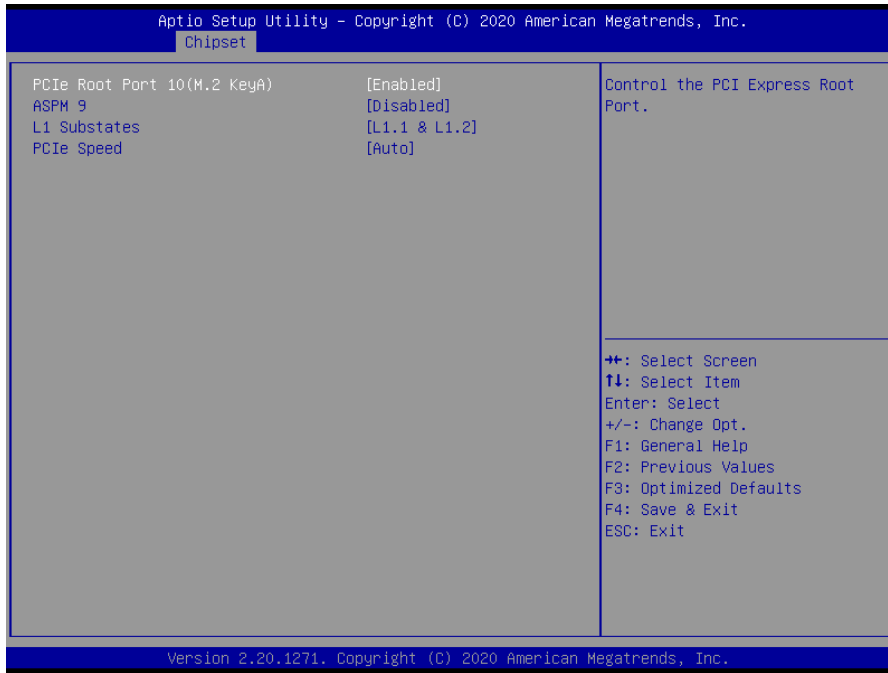

Item	Option	Description
PCIe Root Port 10(M.2 KeyA)	Disabled Enabled[Default],	Control the PCI Express Root Port.
ASPM 9	Disabled[Default] L0s L1 L0sL1 Auto,	Set the ASPM Level: Force L0s - Force all links to L0s State AUTO - BIOS auto configure DISABLE - Disables ASPM.
L1 Substates	Disabled L1.1 L1.1 & L1.2[Default],	PCI Express L1 Substates settings.
PCIe Speed	Auto[Default] Gen1 Gen2 Gen3	Configure PCIe speed.

3.6.3.2.1.4 PCIe Root Port 11(M.2 KeyB/SATA0)

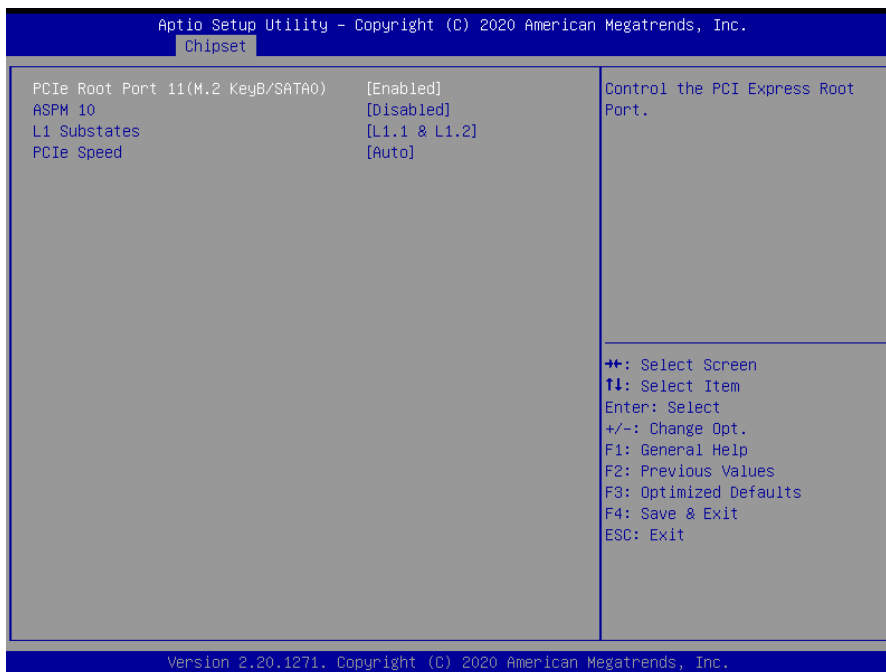

Item	Option	Description
PCIe Root Port 11 (M.2 KeyB/SATA0)	Disabled Enabled[Default],	Control the PCI Express Root Port.
ASPM 10	Disabled[Default] L0s L1 L0sL1 Auto,	Set the ASPM Level: Force L0s - Force all links to L0s State AUTO - BIOS auto configure DISABLE - Disables ASPM.
L1 Substates	Disabled L1.1 L1.1 & L1.2[Default],	PCI Express L1 Substates settings.
PCIe Speed	Auto[Default] Gen1 Gen2 Gen3	Configure PCIe speed.

3.6.3.2.1.5 PCIe Root Port 13(GP PCIe4)

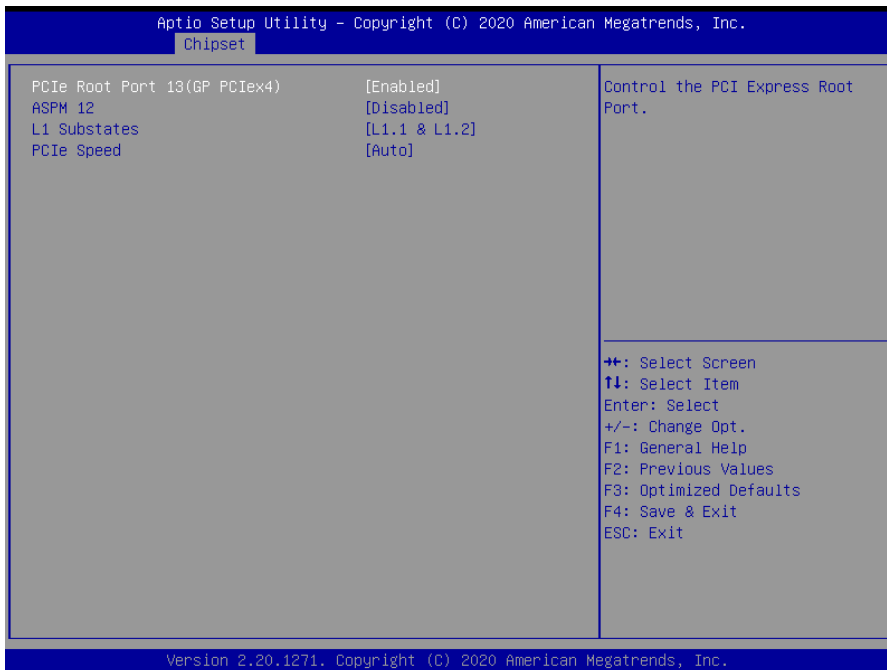

Item	Option	Description
PCIe Root Port 13(GP PCIe4)	Disabled Enabled[Default],	Control the PCI Express Root Port.
ASPM 12	Disabled[Default] L0s L1 L0sL1 Auto,	Set the ASPM Level: Force L0s - Force all links to L0s State AUTO - BIOS auto configure DISABLE - Disables ASPM.
L1 Substates	Disabled L1.1 L1.1 & L1.2[Default],	PCI Express L1 Substates settings.
PCIe Speed	Auto[Default] Gen1 Gen2 Gen3	Configure PCIe speed.

3.6.3.2.2 SATA And RST Configuration



Item	Options	Description
SATA Controller(s)	Enabled[Default] Disabled,	Enable/Disable SATA Device.
SATA Mode Selection	AHCI[Default] RAID	Determines how SATA controller(s) operate.
SATA Test Mode	Enabled[Default] Disabled,	Test Mode Enable/Disable (Loop Back).
Port0	Disabled, Enabled[Default]	Enable or Disable SATA Port.
SATA Device Type	Hard Disk Drive Solid State Drive[Default]	Identify the SATA port is connected to Solid State Drive or Hard Disk Drive.
Port1	Disabled, Enabled[Default]	Enable or Disable SATA Port.
SATA Device Type	Hard Disk Drive[Default] Solid State Drive	Identify the SATA port is connected to Solid State Drive or Hard Disk Drive.

3.6.3.2.3 HD Audio Configuration

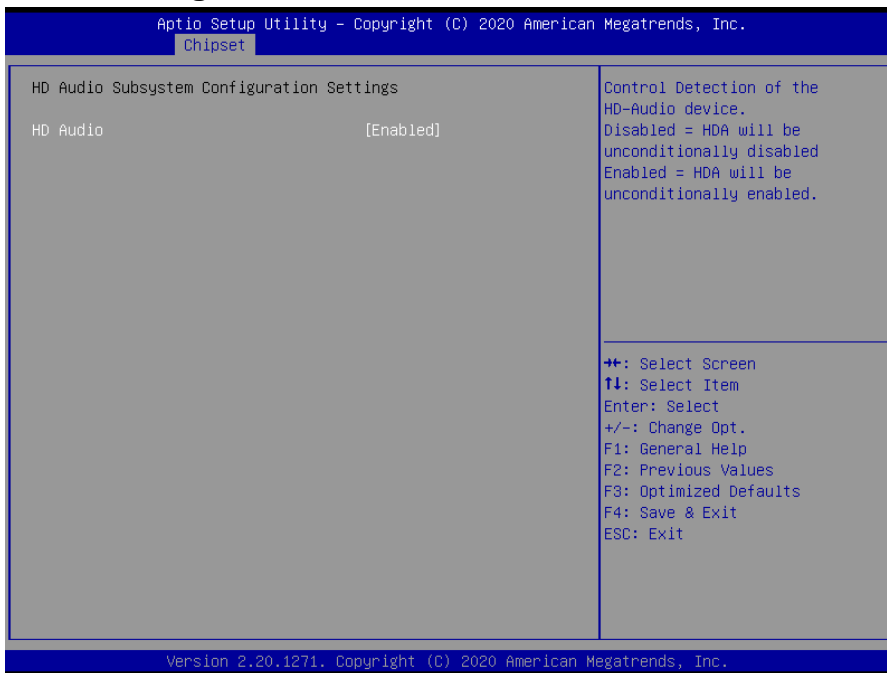

Item	Option	Description
HD Audio	Disabled Enabled[Default],	Control Detection of the HD-Audio device. Disabled = HDA will be unconditionally disabled Enabled = HDA will be unconditionally enabled.

3.6.3.3 Board & Panel Configuration

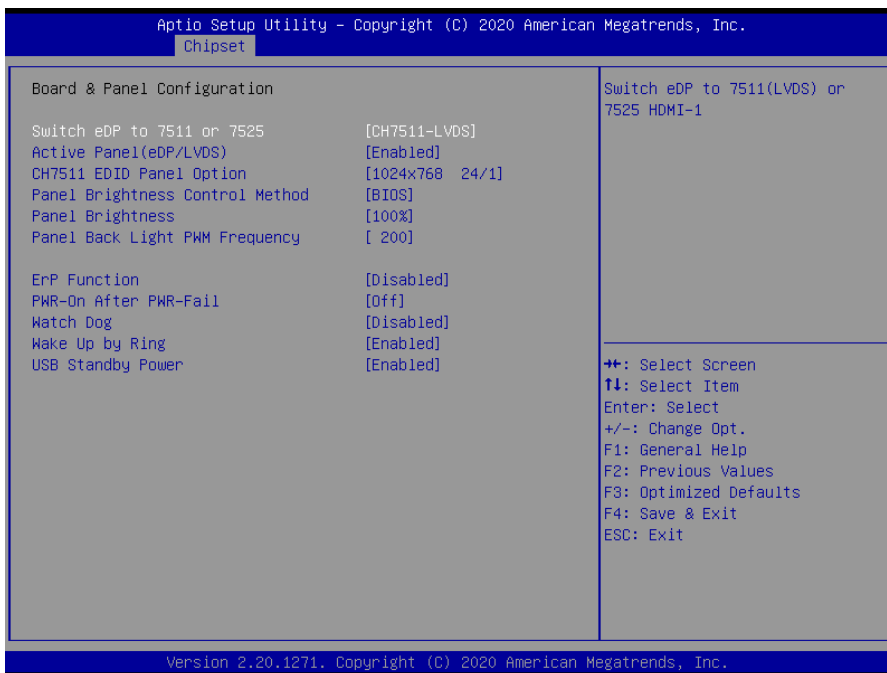

Item	Option	Description
Switch eDP to 7511 or 7525	CH7511-LVDS[Default] CH7525-HDMI1	Switch eDP to 7511(LVDS) or 7525 HDMI-1
Active Panel(eDP/LVDS)	Disabled Enabled[Default],	Active Internal LVDS(eDP->Ch7511 -to-LVDS)
CH7511 EDID Panel Option	1024 x 768 24/1[Default] 800 x 600 18/1 1024 x 768 18/1 1366 x 768 18/1 1024 x 600 18/1 1280 x 800 18/1 1920 x 200 24/2 1920 x 1080 18/2 1280 x 1024 24/2 1440 x 900 18/2 1600 x1200 24/2 1366 x768 24/1 1920 x1080 24/2 1680 x1050 24/2	Port1-EDP to LVDS(Chrotel 7511)Panel EDID Option
Panel Brightness Control Method	BIOS[Default] BR Button VR OS Driver	Panel Brightness Control Method. 1.BIOS 2.OS Driver
Panel Brightness	00% 25% 50% 75% 100%[Default]	Select Panel(eDP/LVDS) back light PWM duty.
Panel Back Light PWM Frequency	200[Default] 300 400 500 700 1k 2k 3k 5k 10k 20k	Select Panel(eDP/LVDS) back light PWM Frequency
ErP Function	Disabled[Default], Enabled	ErP Function (Deep S5).
PWR-On After PWR-Fail	Off[Default], On Last State	AC loss resume.
Watch Dog	Disabled[Default], 30 sec 40 sec 50 sec 1 min 2 min 10 min	Select WatchDog

EMX-WHLGP User's Manual

	30 min	
Wake Up by Ring	Disabled Enabled[Default],	Wake Up by Ring from S3/S4/S5
USB Standby Power	Disabled Enabled[Default],	Enabled/Disabled USB Standby Power during S3/S4/S5

3.6.4 Security

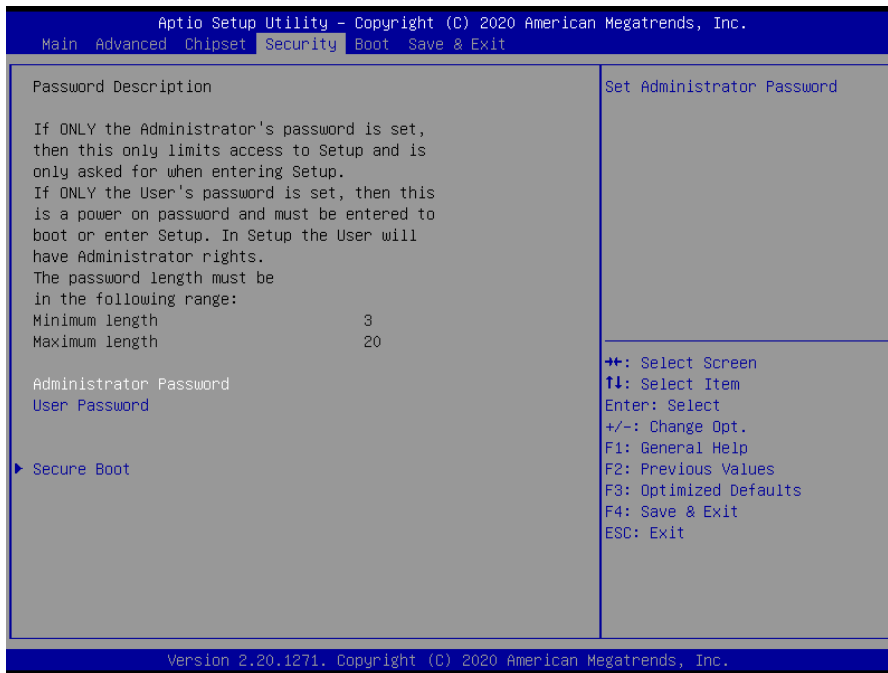

- **Administrator Password**

Set Administrator Password

- **User Password**

Set User Password

3.6.4.1 Secure Boot

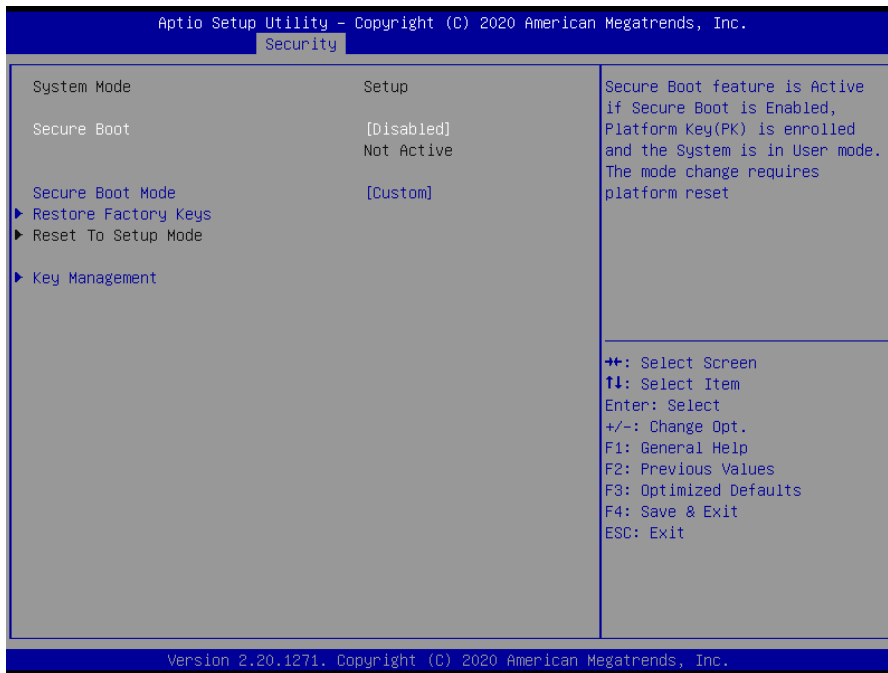

Item		Description
Secure Boot	Disabled Enabled[Default],	Secure Boot feature is Active if Secure Boot is Enabled, Platform Key(PK) is enrolled and the System is in User mode. The mode change requires platform reset
Secure Boot Mode	Standard Custom[Default],	Secure Boot mode options: Standard or Custom. In Custom mode, Secure Boot Policy variables can be configured by a physically present user without full authentication

4.6.4.1.1 Restore Factory Keys

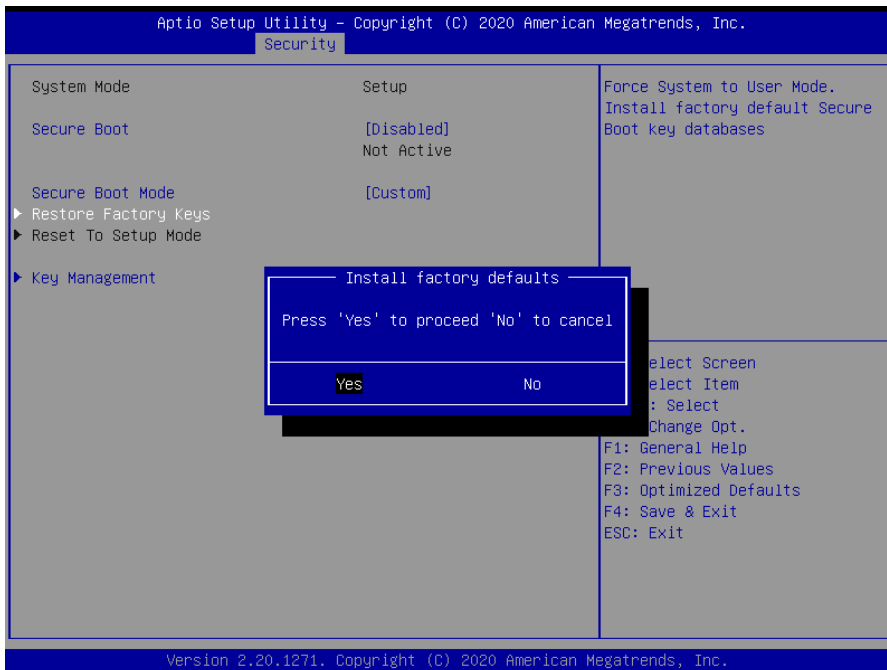

4.6.4.1.2 Reset To Setup Mode

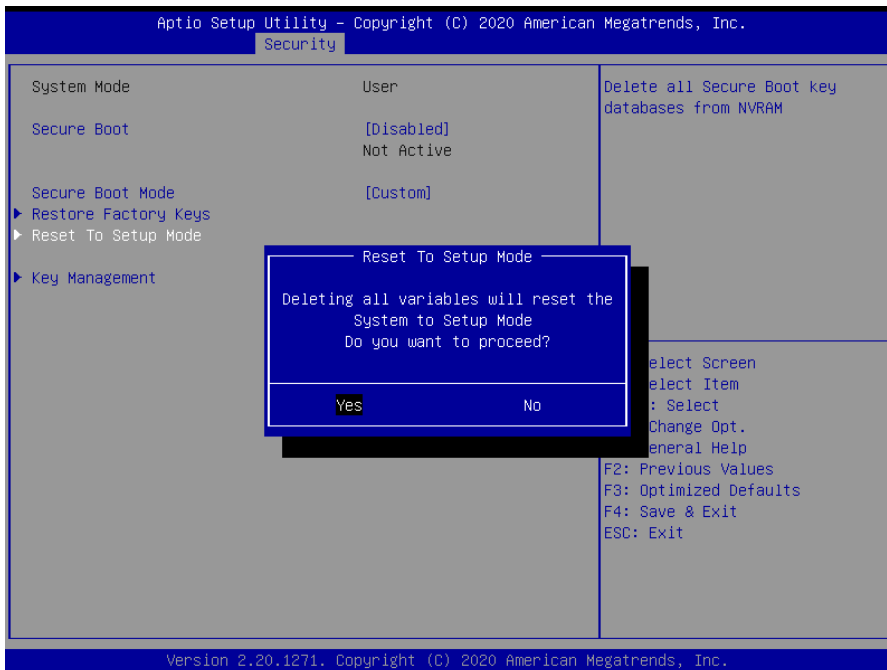

4.6.4.1.3 Key Management

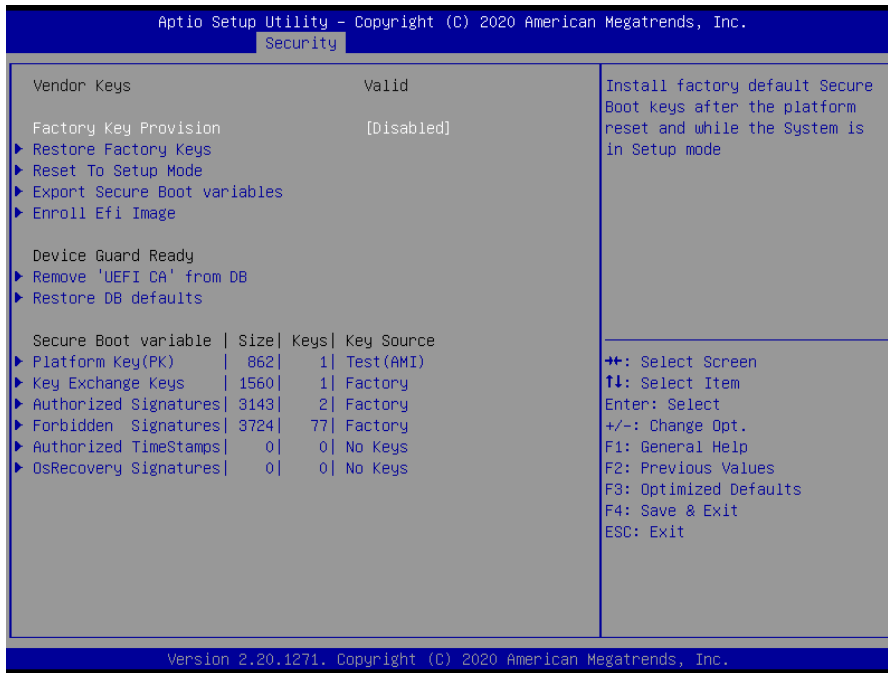

Item	Option	Description
Factory Key Provision	Disabled[Default] Enabled	Install factory default Secure Boot keys after the platform reset and while the System is in Setup mode
Restore Factory Keys		Force System to User Mode. Install factory default Secure Boot key databases
Reset To Setup Mode		Delete all Secure Boot key databases from NVRAM
Export Secure Boot variables		Copy NVRAM content of Secure Boot variables to files in a root folder on a file system device
Enroll Efi Image		Allow the image to run in Secure Boot mode. Enroll SHA256 Hash certificate of a PE image into Authorized Signature Database (db)
Remove 'UEFI CA' from DB		Device Guard ready system must not list 'Microsoft UEFI CA' Certificate in Authorized Signature database (db)
Restore DB defaults		Restore DB variable to factory defaults

EMX-WHLGP User's Manual

3.6.5 Boot

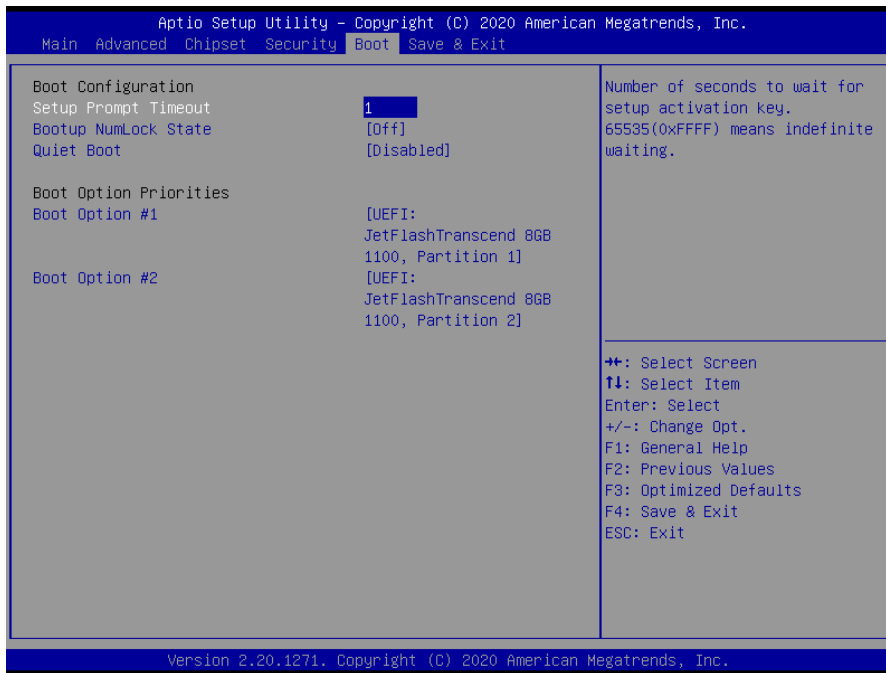

Item	Option	Description
Setup Prompt Timeout	1	Number of seconds to wait for setup activation key. 65535(0xFFFF) means indefinite waiting.
Bootup NumLock State	On Off[Default]	Select the Keyboard NumLock state
Quiet Boot	Disabled[Default] Enabled	Enables or disables Quiet Boot option
Boot Option #1	Sets the system boot order.	
Boot Option #2	Sets the system boot order.	

3.6.6 Save and Exit

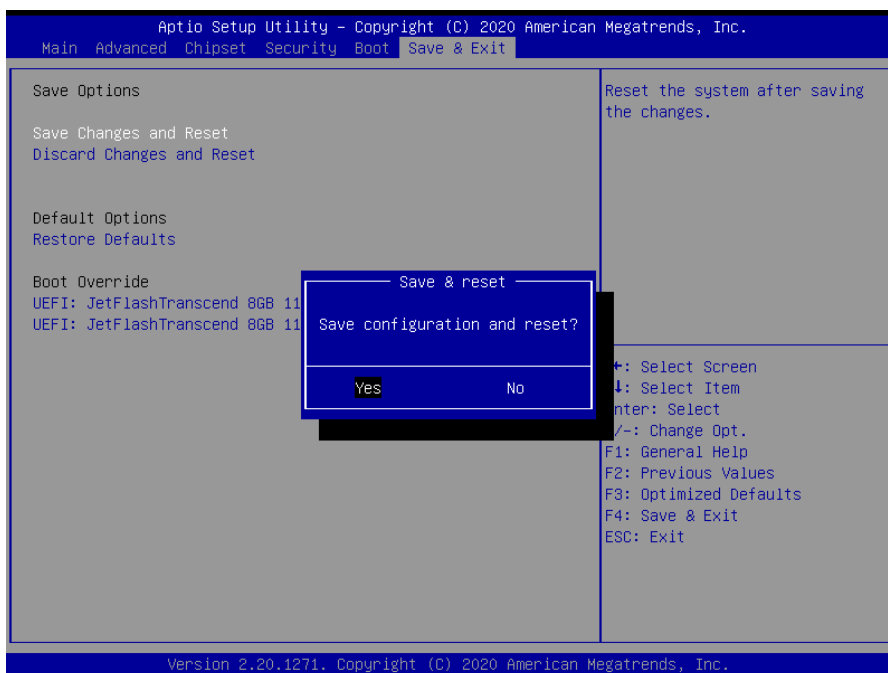
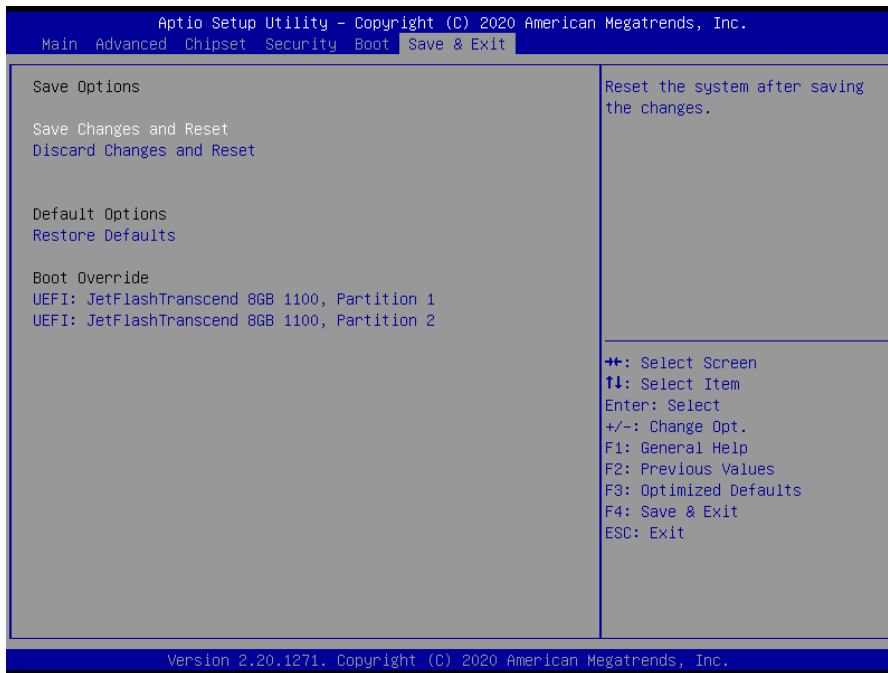

3.6.6.1 Save Changes and Reset

Reset the system after saving the changes.

3.6.6.2 Discard Changes and Reset

Reset system setup without saving any changes.

EMX-WHLGP User's Manual

3.6.6.3 *Restore Defaults*

Restore/Load Default values for all the setup options.

3.6.6.4 *Launch EFI Shell from filesystem device*

Attempts to Launch EFI Shell application (Shell.efi) from one of the available filesystem devices.

4. Drivers Installation



Note: Installation procedures and screen shots in this section are for your reference and may not be exactly the same as shown on your screen.

4.1 Install Chipset Driver

All drivers can be found on the Avalue Official Website:

<http://www.avalu.com.tw>.



Note: The installation procedures and screen shots in this section are based on Windows 10 operation system.

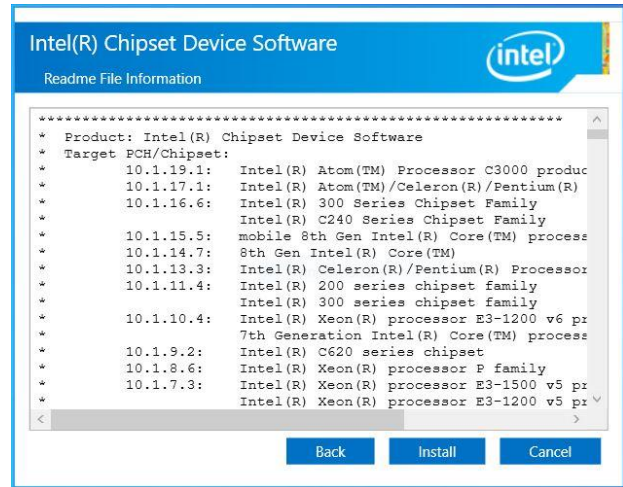

Step 3. Click Install.

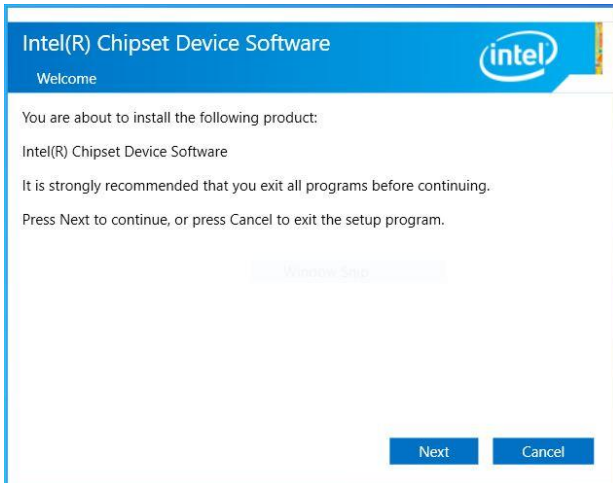

Step1. Click Next.



Step 4. Complete setup.

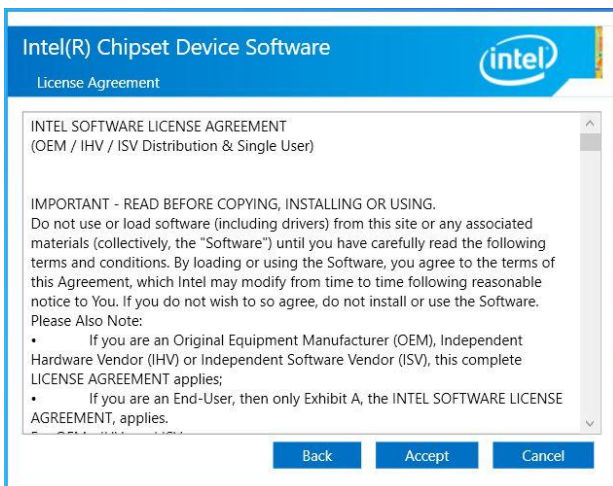

Step 2. Click Accept.

4.2 Install VGA Driver

All drivers can be found on the Avalue Official Website:

<http://www.avalue.com.tw>.



Note: The installation procedures and screen shots in this section are based on Windows 10 operation system.

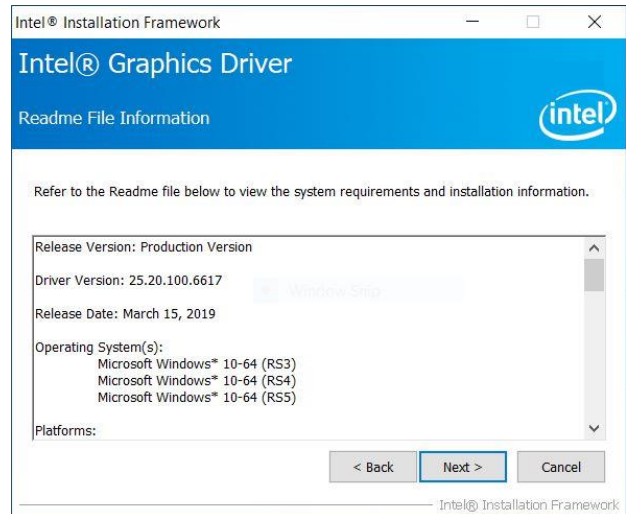

Step 3. Click Install.

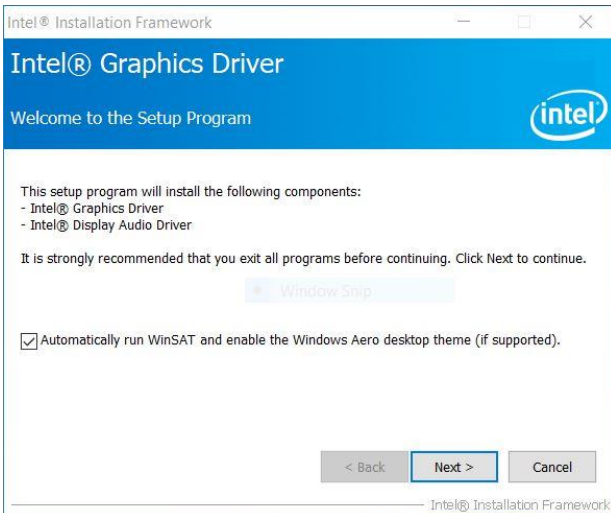

Step 1. Click Next to continue installation.

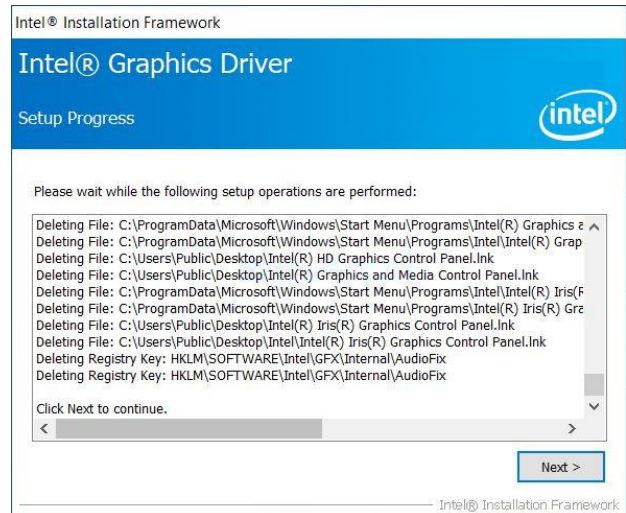

Step 4. Click Next

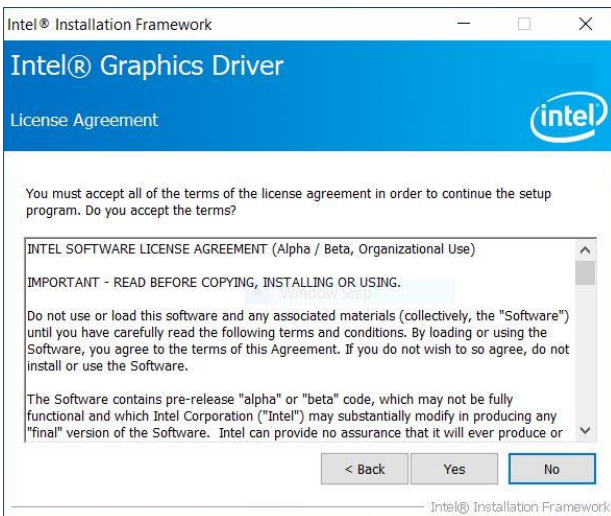

Step 2.
Click **Yes** to accept license agreement.

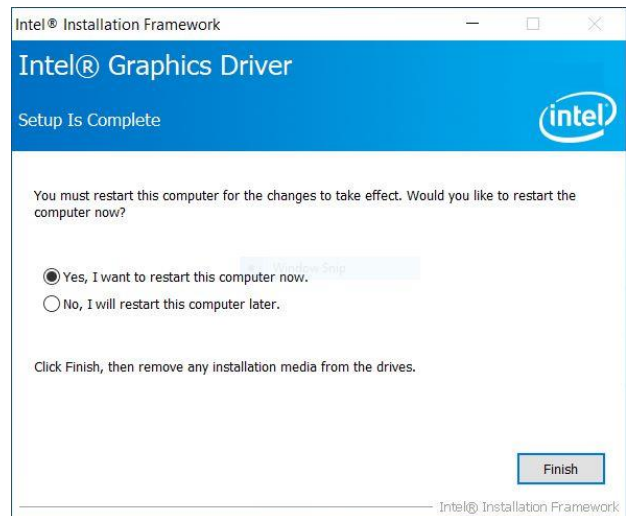

Step 5. Click Finish to complete setup.

4.3 Install ME Driver

All drivers can be found on the Avalue Official Website:

<http://www.avalue.com.tw>.



Note: The installation procedures and screen shots in this section are based on Windows 10 operation system.

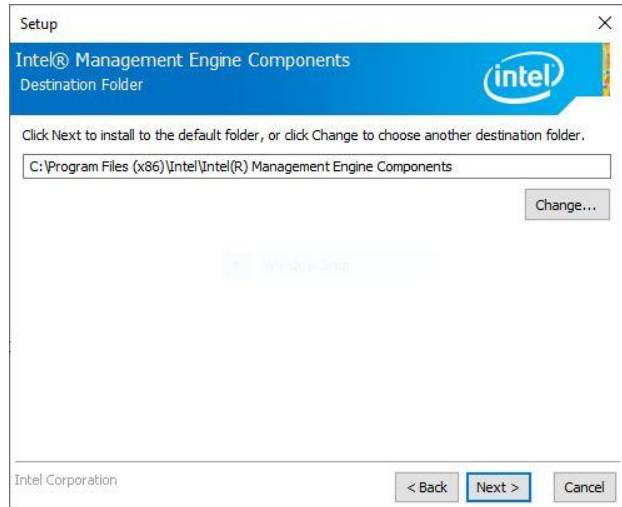

Step 3. Click Next.



Step 1. Click Next to continue setup.

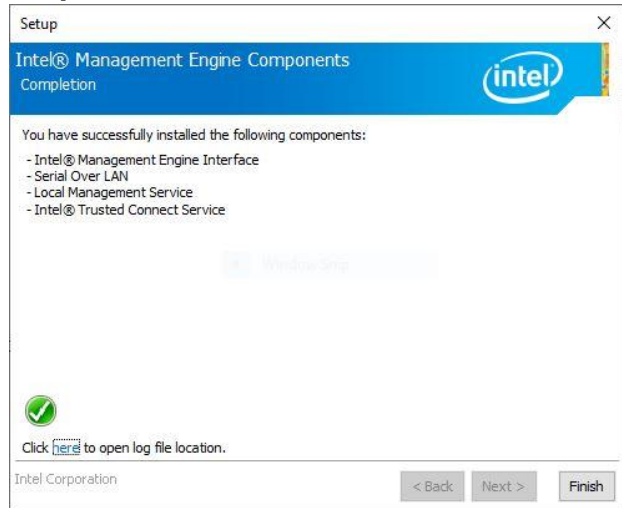

Step 4. Click Finish to complete setup.



Step 2. Click Next.

4.4 Install Audio Driver (For Realtek ALC888S HD Audio)

All drivers can be found on the Avalue Official Website:

<http://www.avalue.com.tw>.



Note: The installation procedures and screen shots in this section are based on Windows 10 operation system.

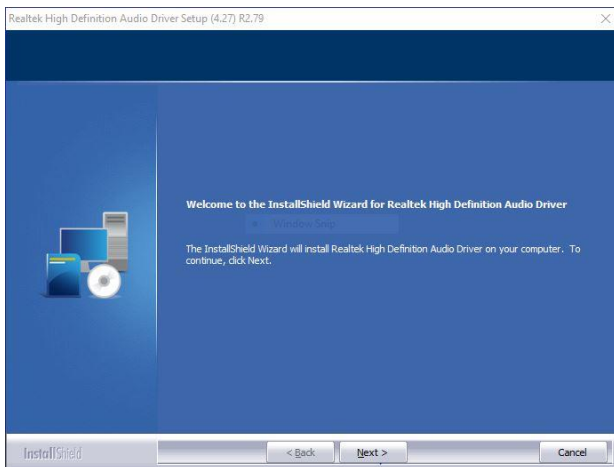

Step1. Click **Next** to Install.

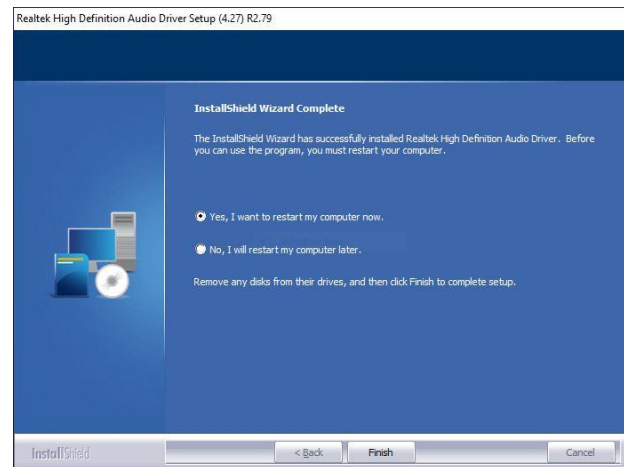

Step 2. Click **Finish** to complete setup.

4.5 Install LAN Driver

All drivers can be found on the Avalue Official Website:

<http://www.avalue.com.tw>.



Note: The installation procedures and screen shots in this section are based on Windows 10 operation system.

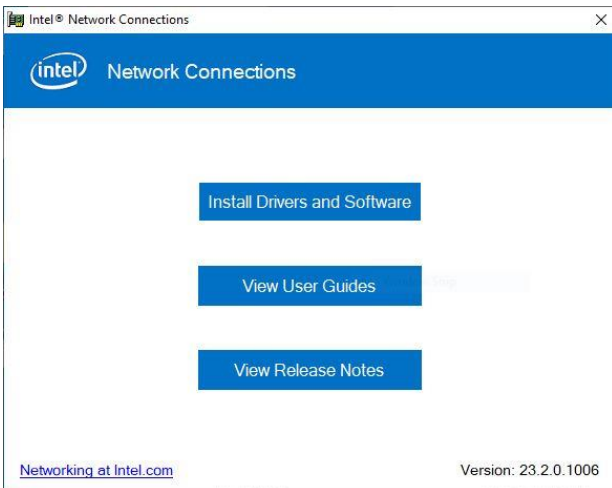

Step 1.
Click **Install Drivers and Software**.

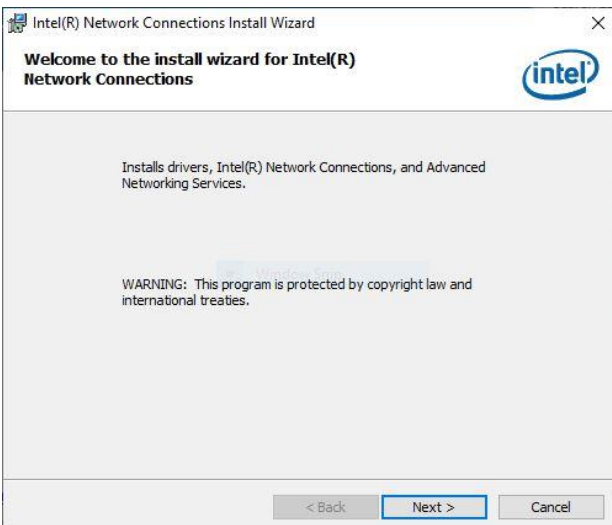

Step 2. Click **Next**.

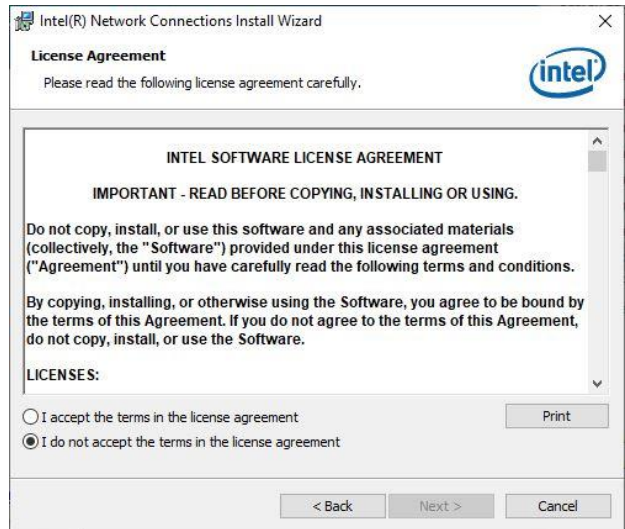

Step 3. Click **Next**.

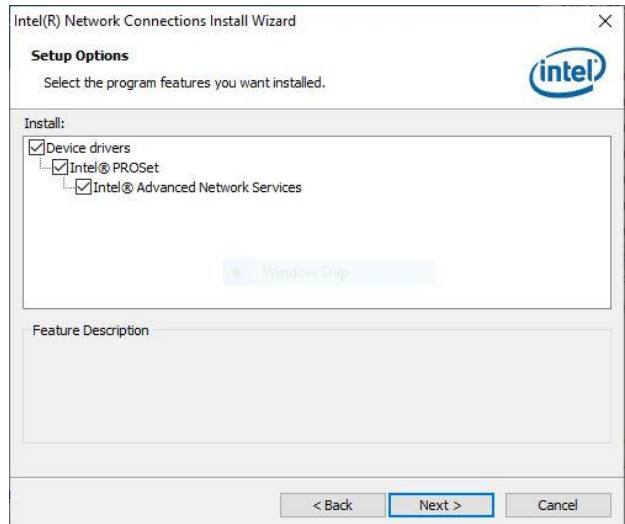

Step 4. Click **Next**.

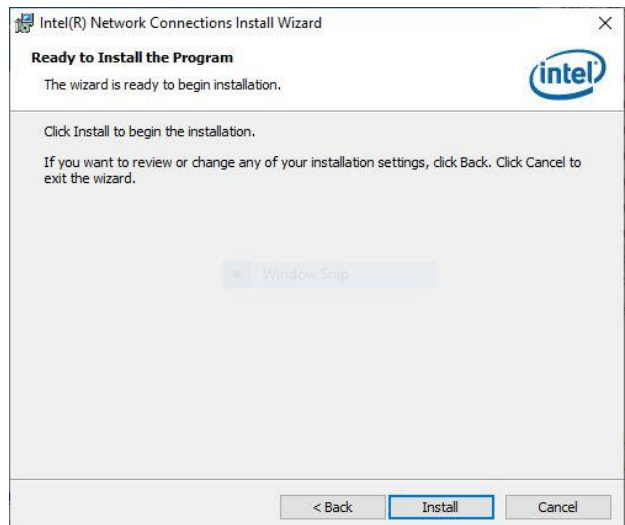

Step 5. Click **Install**.

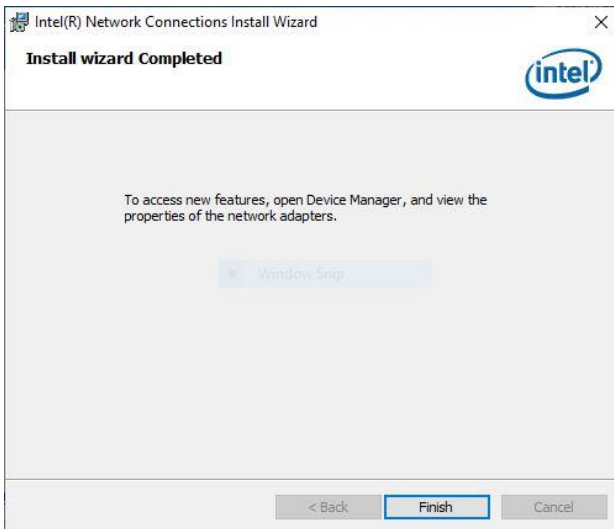

Step 6. Click **Finish** to complete setup.

4.6 Install RST Driver

All drivers can be found on the Avalue Official Website:

<http://www.avalu.com.tw>.



Note: The installation procedures and screen shots in this section are based on Windows 10 operation system.

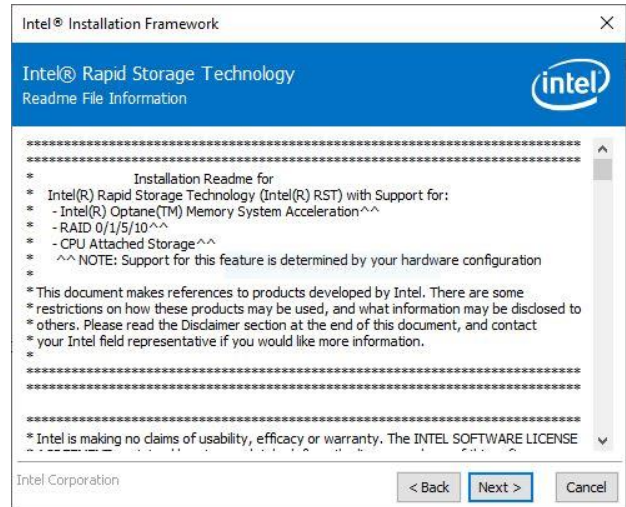

Step 3. Click Next.

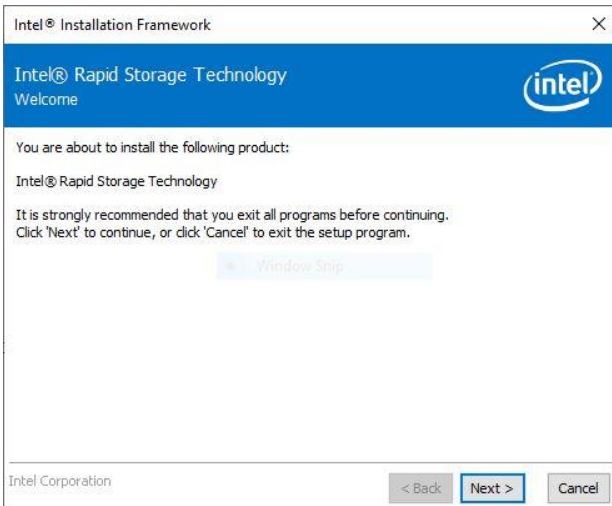

Step 1. Click Next to continue installation.

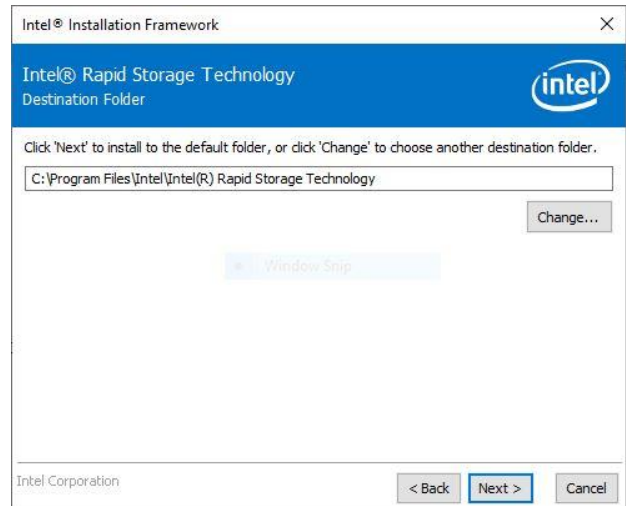

Step 4. Click Next.

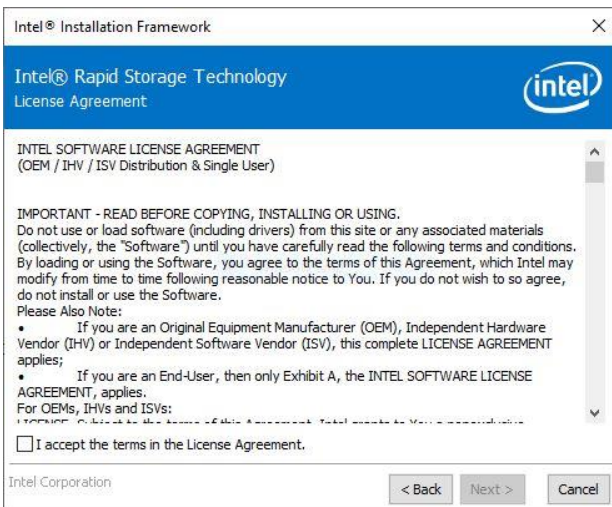

Step 2. Click Next.

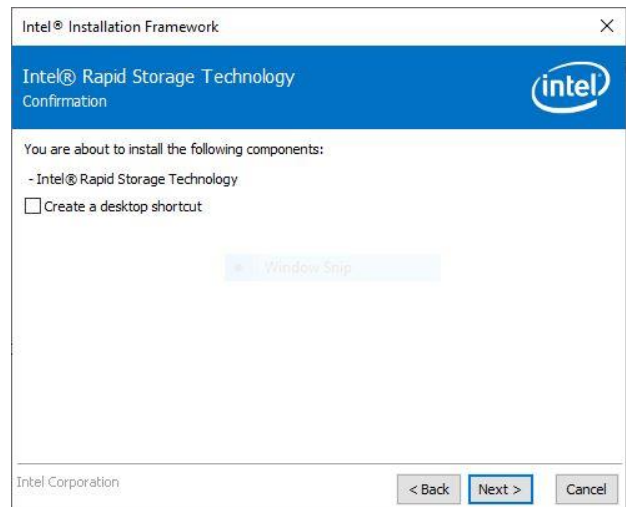

Step 5. Click Next.

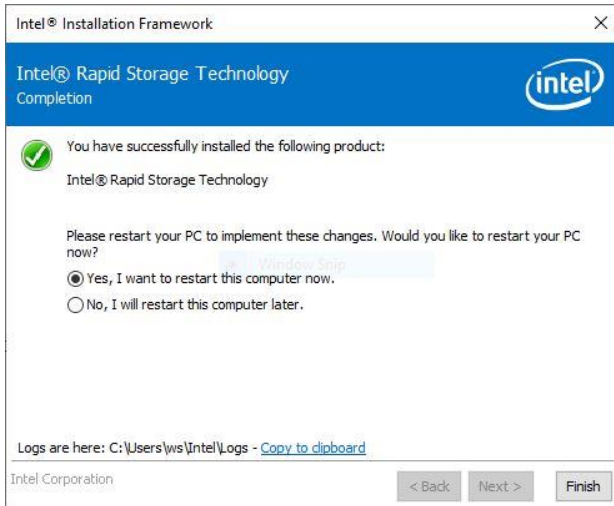

Step 6. Click **Finish** to complete setup.

5. Mechanical Drawing



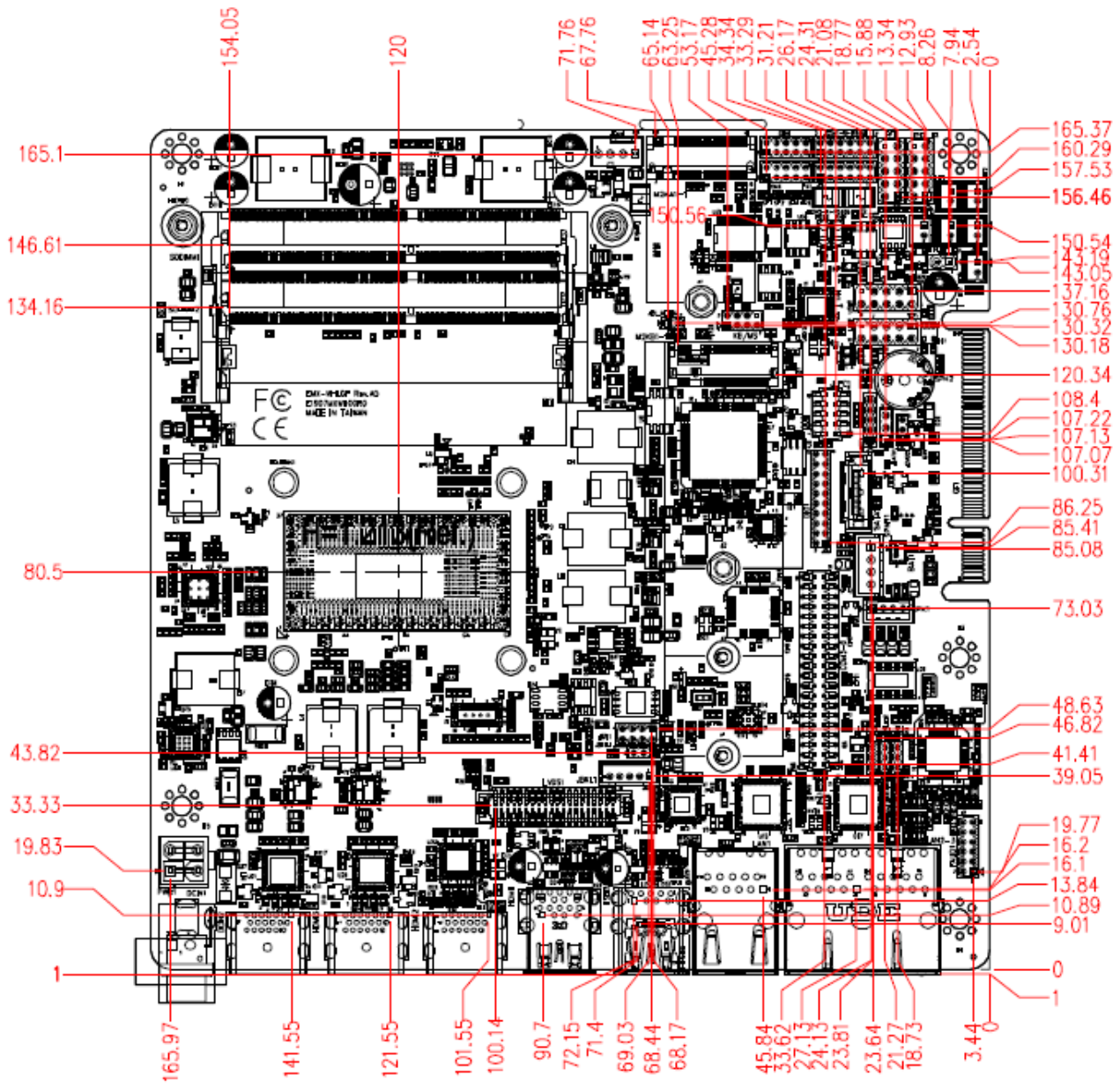

Unit: mm

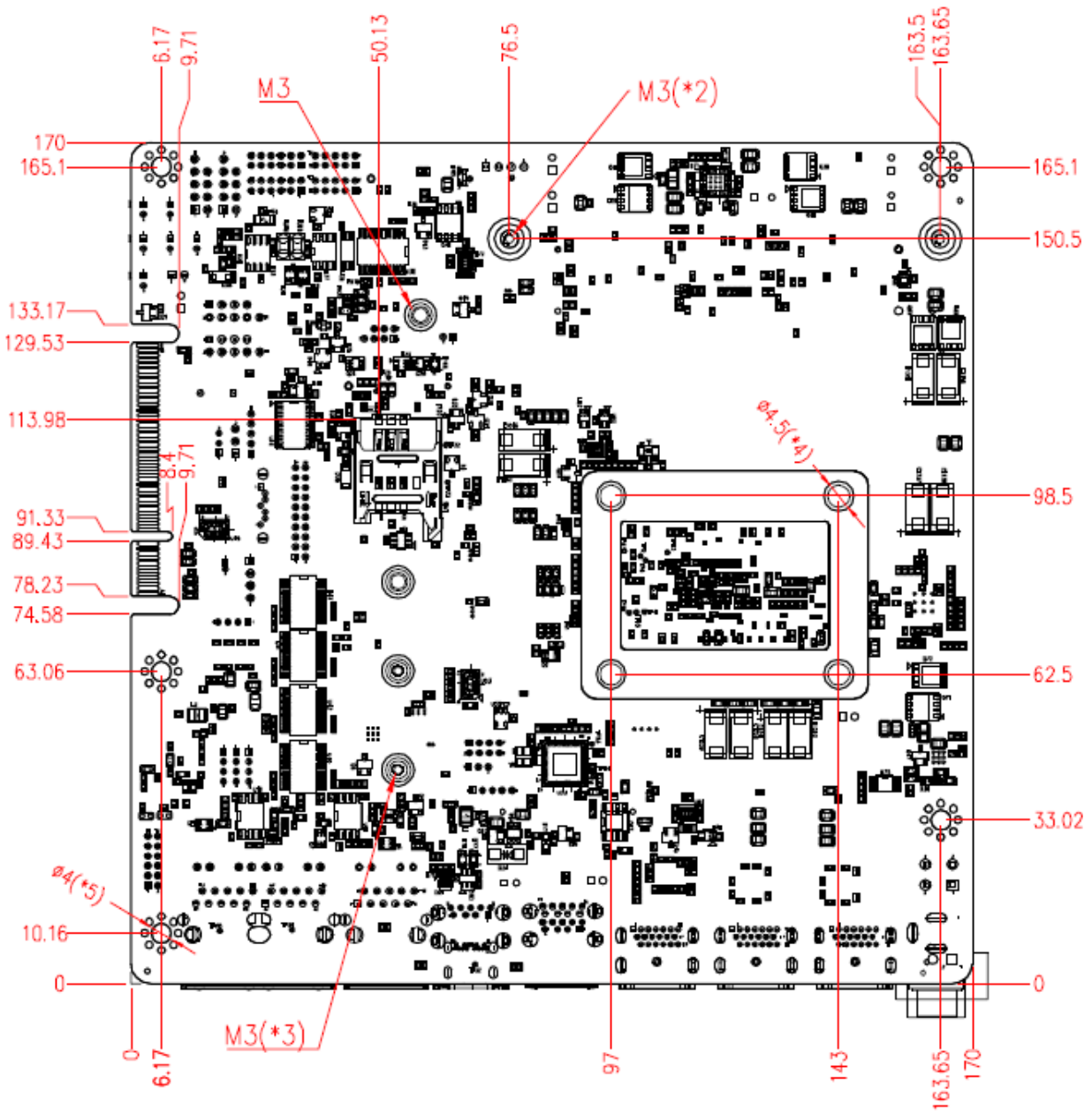

Unit: mm

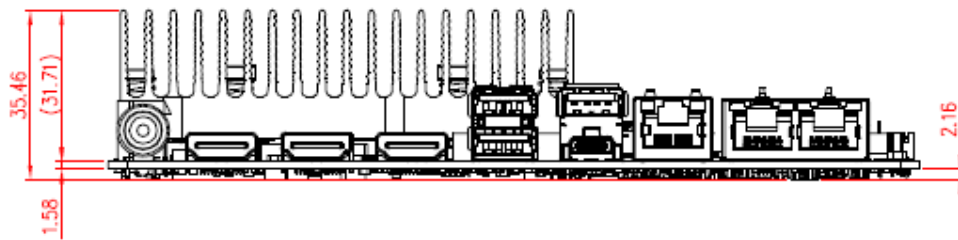
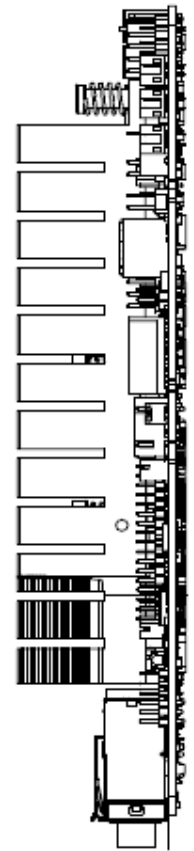
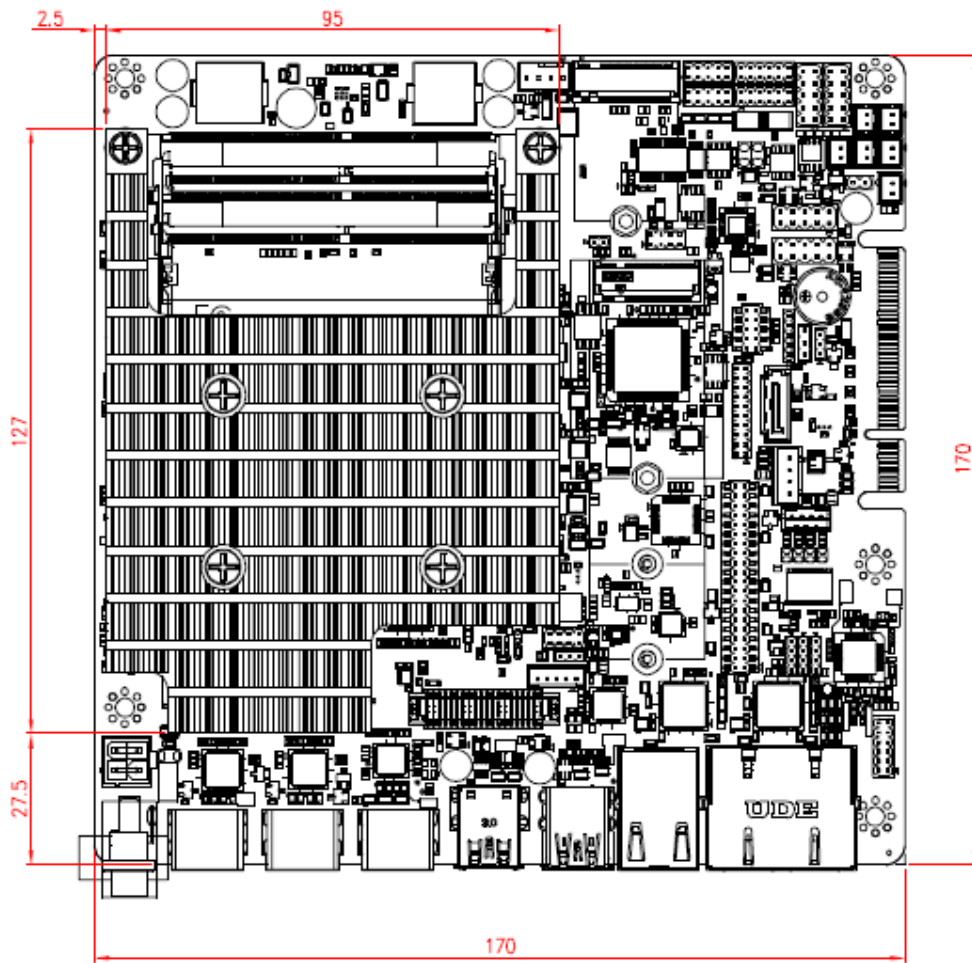

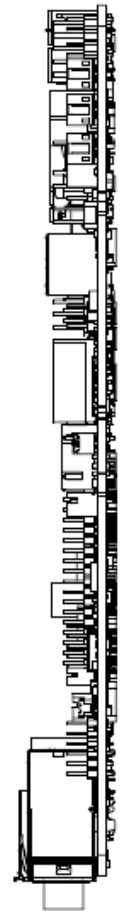
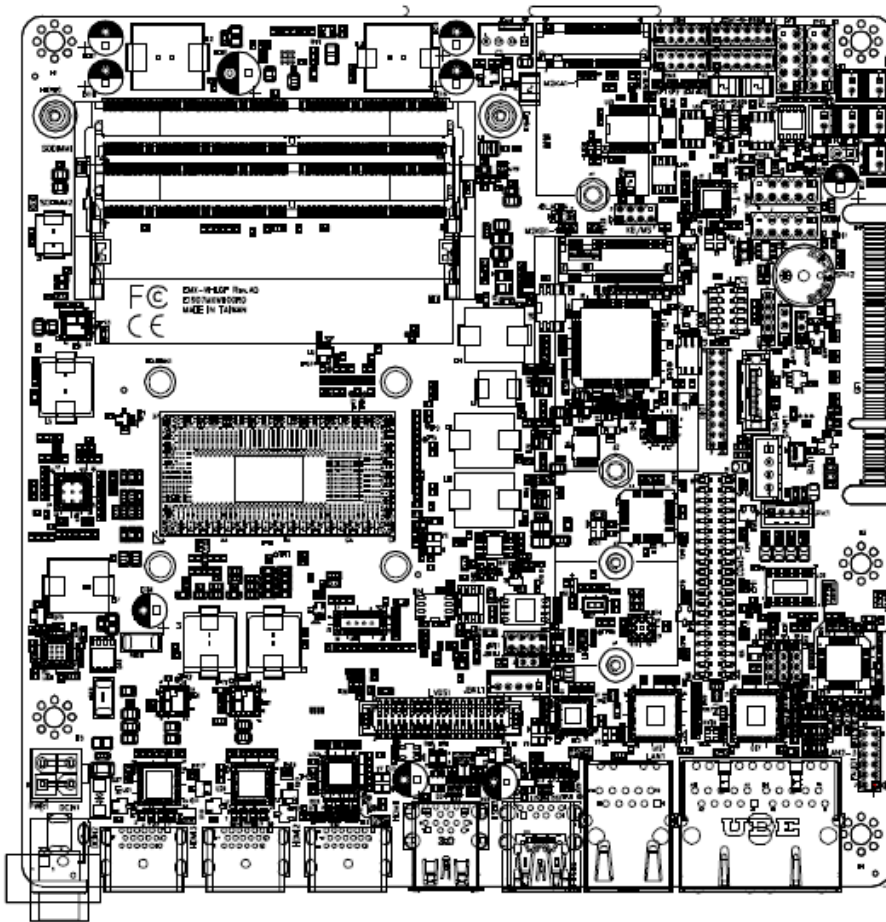

Unit: mm

