

# ESM-SKLA

6th Gen Intel® Xeon® E3-1500 series /Core™ Processor i3 series

Type6 COMe Basic Module with Intel® CM236 Chipset

## User's Manual

1<sup>st</sup> Ed – 05 July 2016

### Copyright Notice

Copyright © 2016 Avalue Technology Inc., ALL RIGHTS RESERVED.

Part No. E2047288100R

## FCC Statement



THIS DEVICE COMPLIES WITH PART 15 FCC RULES. OPERATION IS SUBJECT TO THE FOLLOWING TWO CONDITIONS:

(1) THIS DEVICE MAY NOT CAUSE HARMFUL INTERFERENCE.

(2) THIS DEVICE MUST ACCEPT ANY INTERFERENCE RECEIVED INCLUDING INTERFERENCE THAT MAY CAUSE UNDESIRE OPERATION.

THIS EQUIPMENT HAS BEEN TESTED AND FOUND TO COMPLY WITH THE LIMITS FOR A CLASS "A" DIGITAL DEVICE, PURSUANT TO PART 15 OF THE FCC RULES.

THESE LIMITS ARE DESIGNED TO PROVIDE REASONABLE PROTECTION AGAINST HARMFUL INTERFERENCE WHEN THE EQUIPMENT IS OPERATED IN A COMMERCIAL ENVIRONMENT. THIS EQUIPMENT GENERATES, USES, AND CAN RADIATE RADIO FREQUENCY ENERGY AND, IF NOT INSTALLED AND USED IN ACCORDANCE WITH THE INSTRUCTION MANUAL, MAY CAUSE HARMFUL INTERFERENCE TO RADIO COMMUNICATIONS.

OPERATION OF THIS EQUIPMENT IN A RESIDENTIAL AREA IS LIKELY TO CAUSE HARMFUL INTERFERENCE IN WHICH CASE THE USER WILL BE REQUIRED TO CORRECT THE INTERFERENCE AT HIS OWN EXPENSE.

## Notice

This guide is designed for experienced users to setup the system within the shortest time. For detailed information, please always refer to the electronic user's manual.

## Copyright Notice

Copyright © 2016 Avalue Technology Inc., ALL RIGHTS RESERVED.

No part of this document may be reproduced, copied, translated, or transmitted in any form or by any means, electronic or mechanical, for any purpose, without the prior written permission of the original manufacturer.

## Trademark Acknowledgement

Brand and product names are trademarks or registered trademarks of their respective owners.

## Disclaimer

Avalue Technology Inc. reserves the right to make changes, without notice, to any product, including circuits and/or software described or contained in this manual in order to improve design and/or performance. Avalue Technology assumes no responsibility or liability for the use of the described product(s), conveys no license or title under any patent, copyright, or masks work rights to these products, and makes no representations or warranties that

these products are free from patent, copyright, or mask work right infringement, unless otherwise specified. Applications that are described in this manual are for illustration purposes only. Avalue Technology Inc. makes no representation or warranty that such application will be suitable for the specified use without further testing or modification.

### Life Support Policy

Avalue Technology's PRODUCTS ARE NOT FOR USE AS CRITICAL COMPONENTS IN LIFE SUPPORT DEVICES OR SYSTEMS WITHOUT THE PRIOR WRITTEN APPROVAL OF Avalue Technology Inc.

As used herein:

1. Life support devices or systems are devices or systems which, (a) are intended for surgical implant into body, or (b) support or sustain life and whose failure to perform, when properly used in accordance with instructions for use provided in the labeling, can be reasonably expected to result in significant injury to the user.
2. A critical component is any component of a life support device or system whose failure to perform can be reasonably expected to cause the failure of the life support device or system, or to affect its safety or effectiveness.

### A Message to the Customer

#### *Avalue Customer Services*

Each and every Avalue's product is built to the most exacting specifications to ensure reliable performance in the harsh and demanding conditions typical of industrial environments. Whether your new Avalue device is destined for the laboratory or the factory floor, you can be assured that your product will provide the reliability and ease of operation for which the name Avalue has come to be known.

Your satisfaction is our primary concern. Here is a guide to Avalue's customer services. To ensure you get the full benefit of our services, please follow the instructions below carefully.

#### *Technical Support*

We want you to get the maximum performance from your products. So if you run into technical difficulties, we are here to help. For the most frequently asked questions, you can easily find answers in your product documentation. These answers are normally a lot more detailed than the ones we can give over the phone. So please consult the user's manual first.

To receive the latest version of the user's manual; please visit our Web site at:

<http://www.avalue.com.tw/>

# CONTENT

<b>1. Getting Started</b> .....	<b>7</b>
1.1 Safety Precautions .....	7
1.2 Packing List.....	7
1.3 Document Amendment History .....	8
1.4 Manual Objectives.....	9
1.5 System Specifications .....	10
1.6 Architecture Overview—Block Diagram .....	12
<b>2. Hardware Configuration</b> .....	<b>13</b>
2.1 Product Overview.....	14
2.2 Installation Procedure .....	16
2.2.1 Main Memory.....	17
2.3 Connector List.....	19
2.4 Setting Jumpers & Connectors .....	20
2.4.1 AT/ATX mode selector (SW1).....	20
2.4.1.1 Signal Description –AT/ATX mode selection.....	20
2.4.2 COM Express Connector 1 (CN1A) .....	21
2.4.2.1 Signal Description – COM Express Connector 1 (CN1A).....	25
2.4.2.1.1 Audio Signals .....	25
2.4.2.1.2 Gigabit Ethernet Signals .....	25
2.4.2.1.3 PCI Express Signals.....	25
2.4.2.1.4 Flat Panel LVDS Signals.....	26
2.4.2.1.5 LPC Signals.....	26
2.4.2.1.6 Miscellaneous Signals.....	26
2.4.2.1.7 GPIO Signals.....	26
2.4.2.1.8 Power Signals .....	27
2.4.2.1.9 Power & System Management Signals.....	27
2.4.2.1.10 SATA Signals.....	28
2.4.2.1.11 VGA Signals.....	28
2.4.2.1.12 USB Signals.....	28
2.4.2.1.13 I2C Signals.....	28
2.4.2.1.14 COM.0 Pins Signals.....	28
2.4.3 COM Express Connector 2 (CN1B) .....	29
2.4.3.1 Signal Description – COM Express Connector 2 (CN1B).....	33
2.4.3.1.1 USB3.0 Signals .....	33

2.4.3.1.2 PEG Signals .....	33
2.4.3.1.3 DDI Signals.....	33
<b>3.BIOS Setup .....</b>	<b>34</b>
3.1 Introduction .....	35
3.2 Starting Setup .....	35
3.3 Using Setup .....	36
3.4 Getting Help.....	37
3.5 In Case of Problems.....	37
3.6 BIOS setup.....	38
3.6.1 Main Menu.....	38
3.6.1.1 System Language.....	39
3.6.1.2 System Date .....	39
3.6.1.3 System Time.....	39
3.6.2 Advanced Menu .....	40
3.6.2.1 Driver Health.....	40
3.6.2.2 Trusted Computing .....	41
3.6.2.3 APCI Settings .....	42
3.6.2.4 IT8528 Super IO Configuration.....	43
3.6.2.4.1 Serial Port 1 Configuration .....	44
3.6.2.4.2 Serial Port 2 Configuration .....	44
3.6.2.5 AMT Configuration.....	45
3.6.2.6 PCH-FW Configuration.....	46
3.6.2.6.1 Firmware Update Configuration.....	47
3.6.2.7 H/W Monitor.....	47
3.6.2.7.1 Smart Fan Mode Configuration .....	48
3.6.2.8 S5 RTC Wake Settings.....	49
3.6.2.9 Serial Port Console Redirection .....	51
3.6.2.10 CPU Configuration.....	51
3.6.2.11 Intel TXT Configuration.....	53
3.6.2.12 SATA Configuration.....	53
3.6.2.13 Network Stack Configuration .....	54
3.6.2.14 CSM Configuration .....	56
3.6.2.15 USB Configuration .....	57
3.6.3 Chipset.....	58
3.6.3.1 System Agent (SA) Configuration.....	59
3.6.3.1.1 Graphics Configuration .....	59
3.6.3.1.2 DMI/OPI Configuration .....	61
3.6.3.1.3 PEG Port Configuration .....	62
3.6.3.1.4 Memory Configuration .....	64
3.6.3.1.5 GT- Power Management Control.....	65

## **ESM-SKLA User's Manual**

3.6.3.2	PCH-IO Configuration.....	65
3.6.3.2.1	PCI Express Configuration .....	66
3.6.3.2.2	USB Configuration .....	72
3.6.3.2.3	HD Audio Configuration .....	72
3.6.4	Security.....	73
3.6.4.1	Secure Boot menu .....	74
3.6.4.1.1	Key Management.....	75
3.6.5	Boot .....	75
3.6.6	Save and exit.....	76
3.6.6.1	Save Changes and Reset.....	76
3.6.6.2	Discard Changes and Reset.....	76
3.6.6.3	Restore Defaults .....	76
3.6.6.4	Launch EFI Shell from filesystem device .....	77
<b>4.</b>	<b>Drivers Installation.....</b>	<b>78</b>
4.1	Install Chipset Driver .....	79
4.2	Install Display Driver .....	80
4.3	Install LAN Driver (For Intel I219LM).....	81
4.4	Install ME Driver.....	82
<b>5.</b>	<b>Mechanical Drawing .....</b>	<b>83</b>

# 1. Getting Started

## 1.1 Safety Precautions

### Warning!



Always completely disconnect the power cord from your chassis whenever you work with the hardware. Do not make connections while the power is on. Sensitive electronic components can be damaged by sudden power surges. Only experienced electronics personnel should open the PC chassis.

### Caution!



Always ground yourself to remove any static charge before touching the CPU card. Modern electronic devices are very sensitive to static electric charges. As a safety precaution, use a grounding wrist strap at all times. Place all electronic components in a static-dissipative surface or static-shielded bag when they are not in the chassis.

## 1.2 Packing List

Before you begin installing your single board, please make sure that the following materials have been shipped:

- 1 x ESM-SKLA 6th Gen Intel® Xeon® E3-1500 series /Core™ Processor i3 series, Type6 COMe Basic Module with Intel® CM236 Chipset
- 1 x Driver/Utility DVD-ROM
- 5 x Screw
- 1 x Desiccant



---

If any of the above items is damaged or missing, contact your retailer.

---

### 1.3 Document Amendment History

Revision	Date	By	Comment
1 <sup>st</sup>	July 2016	Avalue	Initial Release



## 1.4 Manual Objectives

This manual describes in details Avalue Technology ESM-SKLA Single Board.

We have tried to include as much information as possible but we have not duplicated information that is provided in the standard IBM Technical References, unless it proved to be necessary to aid in the understanding of this board.

We strongly recommend that you study this manual carefully before attempting to set up ESM-SKLA series or change the standard configurations. Whilst all the necessary information is available in this manual we would recommend that unless you are confident, you contact your supplier for guidance.

Please be aware that it is possible to create configurations within the NVRAM that make booting impossible. If this should happen, clear the NVRAM settings, (see the description of the Jumper Settings for details).

If you have any suggestions or find any errors regarding this manual and want to inform us of these, please contact our Customer Service department with the relevant details.

## 1.5 System Specifications

<b>System</b>																												
<b>CPU</b>	Intel® Xeon® Processor E3-1505M v5 (8M Cache, 2.80 GHz) Intel® Xeon® Processor E3-1505L v5 (8M Cache, 2.00 GHz) Intel® Core™ i3-6100E Processor (3M Cache, 2.70 GHz) Intel® Core™ i3-6102E Processor (3M Cache, 1.90 GHz)																											
<b>BIOS</b>	AMI uEFI BIOS, 128 Mbit SPI Flash ROM iAMTsupported																											
<b>System Chipset</b>	Intel chipset CM236																											
<b>I/O Chip</b>	EC(IT8528E)																											
<b>System Memory</b>	Two 260-pin SODIMM DDR4 2133 SDRAM with ECC support																											
<b>Watchdog Timer</b>	H/W Reset, 1sec. ~ 65535sec. and 1sec./step																											
<b>H/W Status Monitor</b>	Monitoring System Temperature, Voltage and FAN Status with Auto Throttling Control																											
<b>Expansion</b>	8 x PCIe * 1 (IBL #546717)																											
<b>I/O</b>																												
<b>MIO</b>	4 x SATAIII (Support RAID0,1,5,10), LPC, I2C,SPI, SMBus, UART																											
<b>USB</b>	8 USB 2.0, 4 USB 3.0																											
<b>GPIO</b>	WDT/I2C/UART x 2 (2-wire; level 3.3V) /HW monitor/FAN/8bit GPIO																											
<b>Display</b>																												
<b>Chipset</b>	Intel® Skylake Processor integrated Graphics																											
<b>Resolution</b>	HDMI 1.4: Max. resolution 4096 x 2304 @24Hz (only one display output) LVDS: Max. resolution 1920 x 1080 @60Hz VGA: Max. resolution 1920 x 1080 @60Hz																											
<b>Multiple Display</b>	Active 3 Display Combinations : IBL#556527 rev 1.2 page 76 <table border="1" data-bbox="515 1514 952 1971"> <thead> <tr> <th>Display1</th> <th>Display2</th> <th>Display3</th> </tr> </thead> <tbody> <tr> <td>DP</td> <td>DP</td> <td>DP</td> </tr> <tr> <td>DP</td> <td>DP</td> <td>HDMI</td> </tr> <tr> <td>DP</td> <td>DP</td> <td>VGA*</td> </tr> <tr> <td>DP</td> <td>HDMI</td> <td>HDMI</td> </tr> <tr> <td>HDMI</td> <td>HDMI</td> <td>HDMI</td> </tr> <tr> <td>DVI</td> <td>DVI</td> <td>DVI</td> </tr> <tr> <td>HDMI</td> <td>DVI</td> <td>DVI</td> </tr> <tr> <td>DVI</td> <td>HDMI</td> <td>HDMI</td> </tr> </tbody> </table> <p>Note:</p>	Display1	Display2	Display3	DP	DP	DP	DP	DP	HDMI	DP	DP	VGA*	DP	HDMI	HDMI	HDMI	HDMI	HDMI	DVI	DVI	DVI	HDMI	DVI	DVI	DVI	HDMI	HDMI
Display1	Display2	Display3																										
DP	DP	DP																										
DP	DP	HDMI																										
DP	DP	VGA*																										
DP	HDMI	HDMI																										
HDMI	HDMI	HDMI																										
DVI	DVI	DVI																										
HDMI	DVI	DVI																										
DVI	HDMI	HDMI																										

	1. For VGA, a DP to VGA converter is required		
	Display1	Display2	Display3
	eDP	DP	DP
	eDP	DP	HDMI
	eDP	HDMI	DP
	eDP	HDMI	HDMI
	eDP	HDMI	DVI
	eDP	DVI	HDMI
	eDP	DVI	DP
	eDP	DP	DVI
	Display1	Display2	Display3
	VGA/DP1	HDMI1	PCIE2(DP/HDMI)**
eDP/LVDS	VGA/DP1	HDMI1	
eDP/LVDS	VGA/DP1	PCIE2(DP/HDMI)**	
eDP/LVDS	HDMI1	PCIE2(DP/HDMI) **	
Note: Use with EEV-EX14			
<b>HDMI</b>	HDMI 1.4		
<b>Audio</b>			
<b>Audio Amp</b>	intel HD audio I/F		
<b>Mechanical &amp; Environmental</b>			
<b>Power Requirement</b>	+9 ~ +19V		
<b>ACPI</b>	Single power ATX Support S0, S3, S4, S5 ACPI 5.0 Compliant		
<b>Power Type</b>	AT/ATX		
<b>Operating Temp.</b>	Standard: 0 to 60°C		
<b>Storage Temp.</b>	-40°C to 75°C		
<b>Operating Humidity</b>	0% ~ 90% relative humidity, non-condensing		
<b>Size (L x W)</b>	125 mm x 95 mm (Please consult product engineers for the production feasibility if the size is larger than 410 x 360mm or smaller than 80 x 70mm)		
<b>Weight</b>	0.44lbs(0.2kg)		



**Note:** Specifications are subject to change without notice.

## 1.6 Architecture Overview—Block Diagram

The following block diagram shows the architecture and main components of ESM-SKLA.

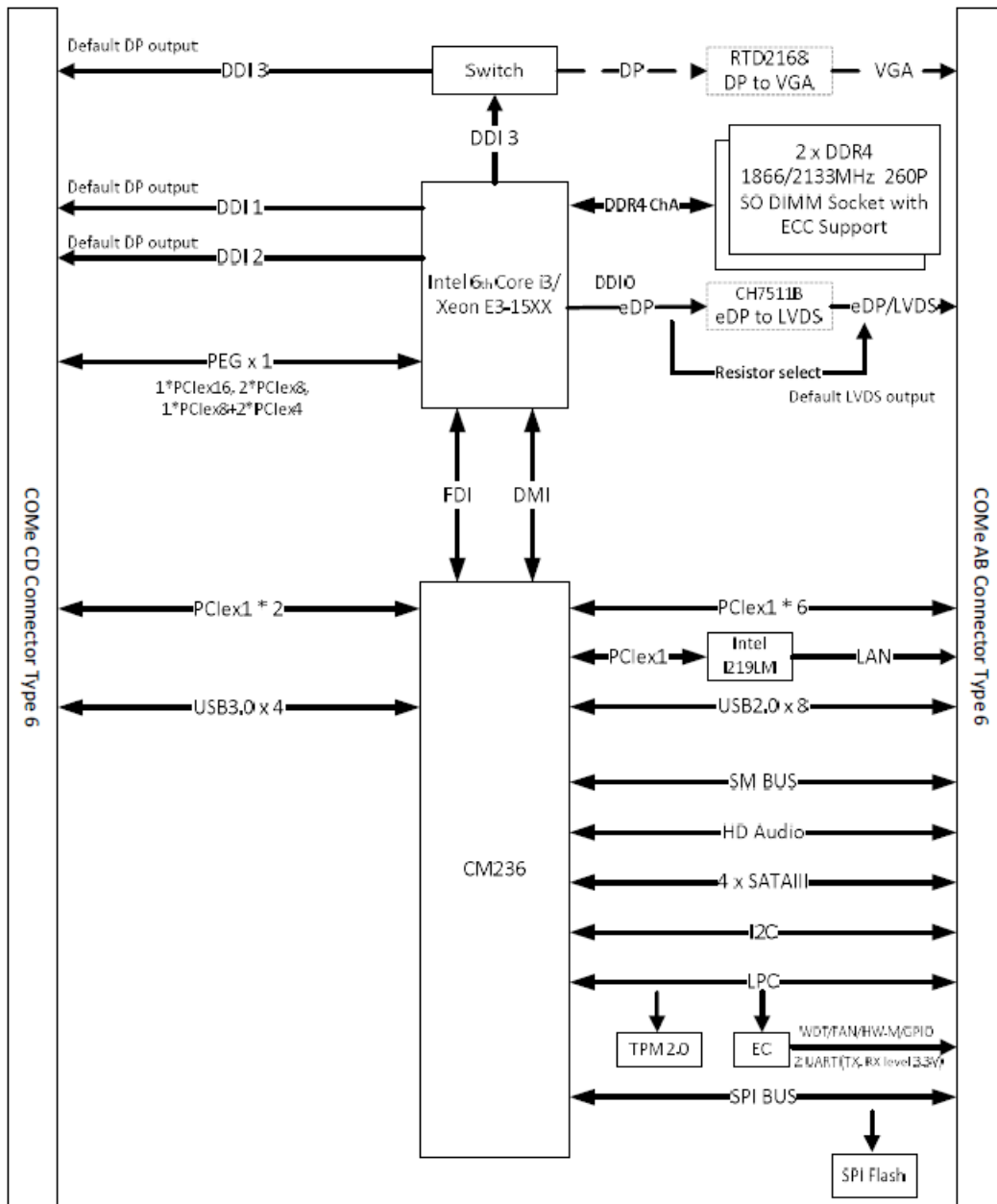

# 2. Hardware Configuration

---

## 2.1 Product Overview

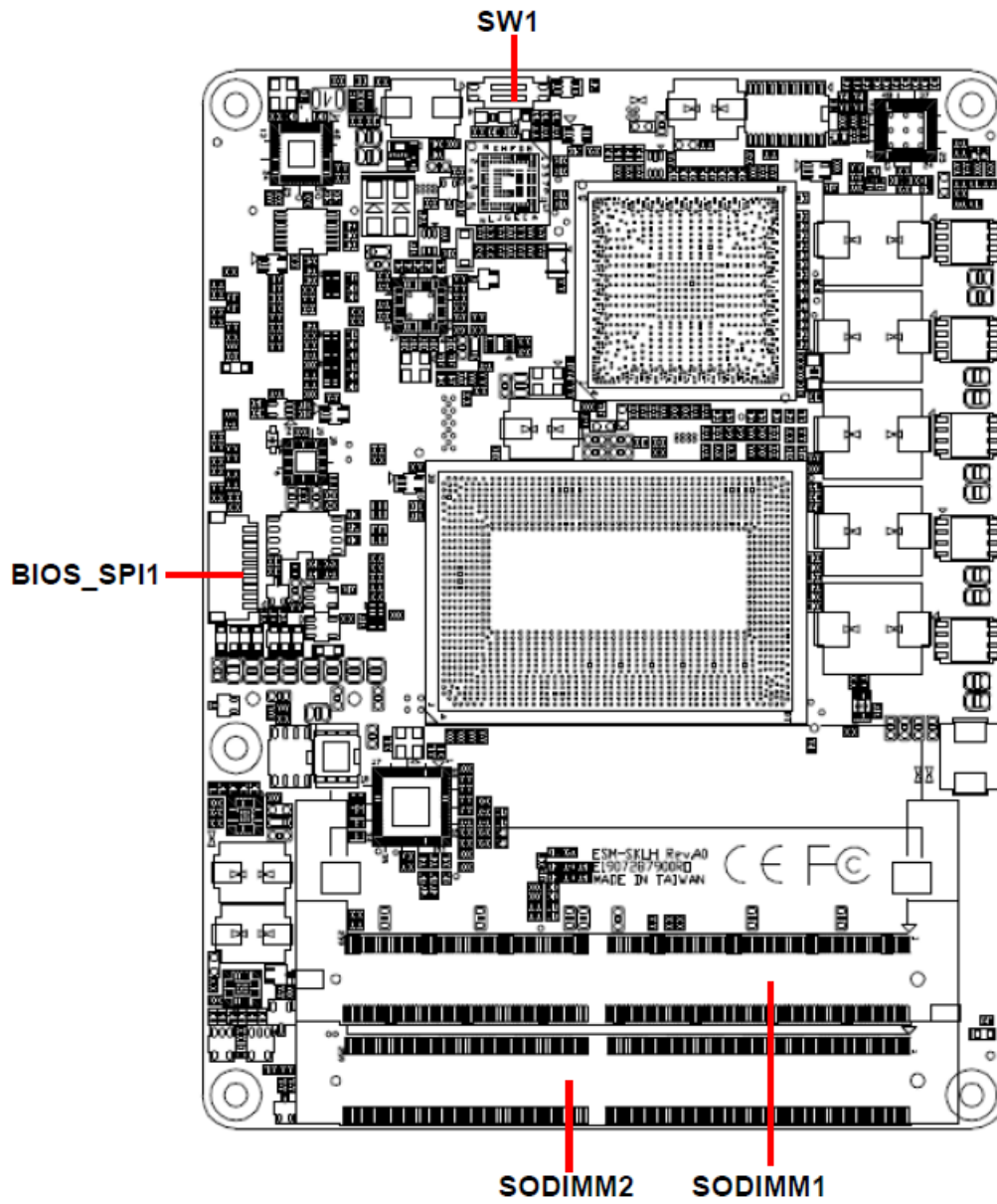

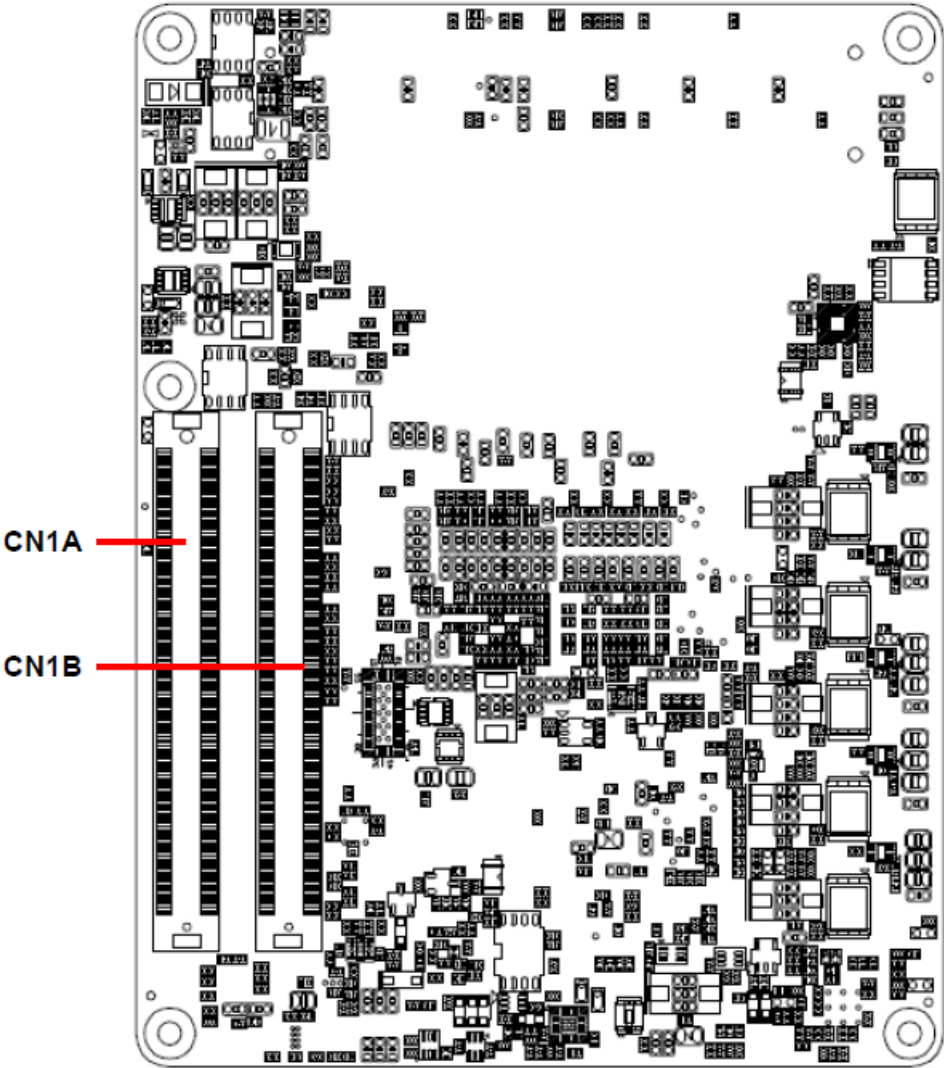

### 2.2 Installation Procedure

This chapter explains you the instructions of how to setup your system.

1. Turn off the power supply.
2. Insert the DIMM module (be careful with the orientation).
3. Insert all external cables for hard disk, keyboard, mouse, USB etc. except for flat panel. A CRT monitor must be connected in order to change NVRAM settings to support flat panel.
4. Connect power supply to the board via the ATXPWR.
5. Turn on the power.
6. Enter the BIOS setup by pressing the delete key during boot up. Use the "Save & Exit \ Restore Defaults" feature.
7. If TFT panel display is to be utilized, make sure the panel voltage is correctly set before connecting the display cable and turning on the power.



### 2.2.1 Main Memory

ESM-SKLA provides two 260-pin SODIMM socket, supports up to 32GB DDR4 2133 SDRAM

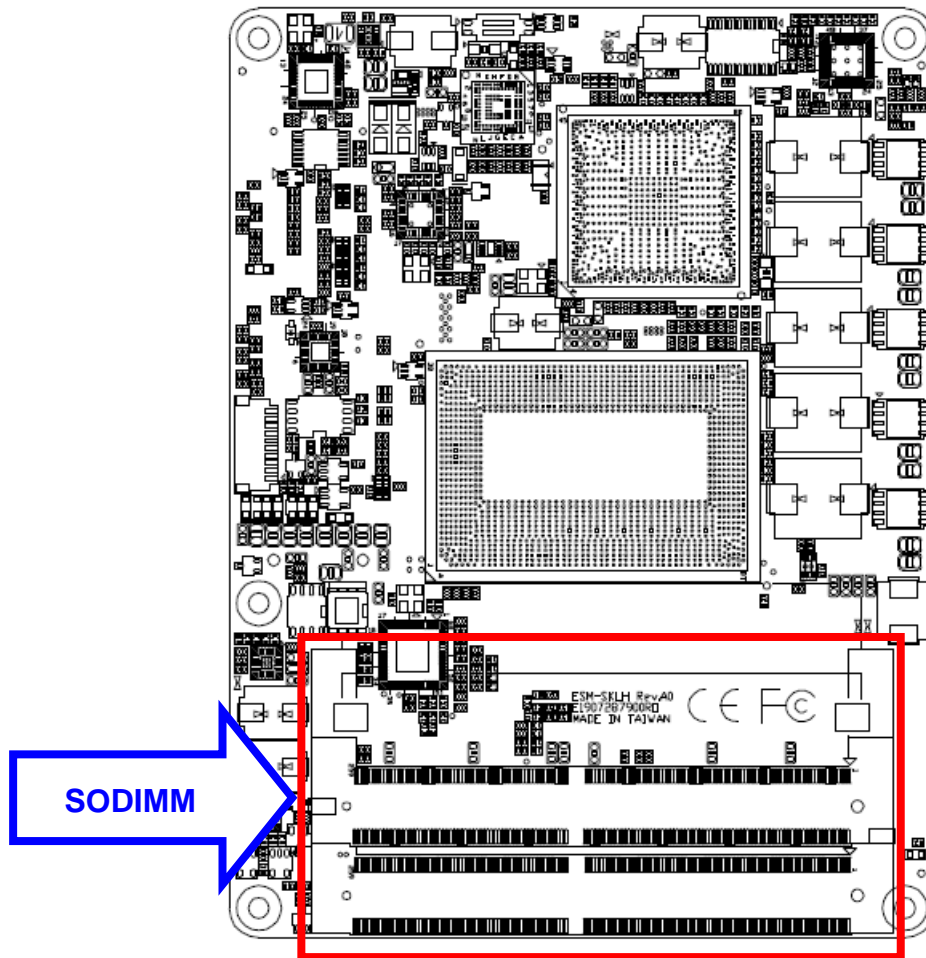

Make sure to unplug the power supply before adding or removing DIMMs or other system components. Failure to do so may cause severe damage to board and components.

## ESM-SKLA User's Manual

- Locate the SODIMM socket on the board.
- Carefully hold two edges of the SODIMM module. avoid touching its connectors.
- Align the notch key on the module with the rib on the slot.
- Firmly press the modules into the socket which automatically snaps into the mounting notch. Do not force the SODIMM module in with extra force as the SODIMM module only fits in one direction.

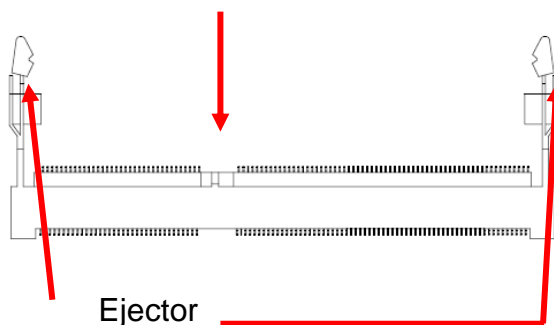
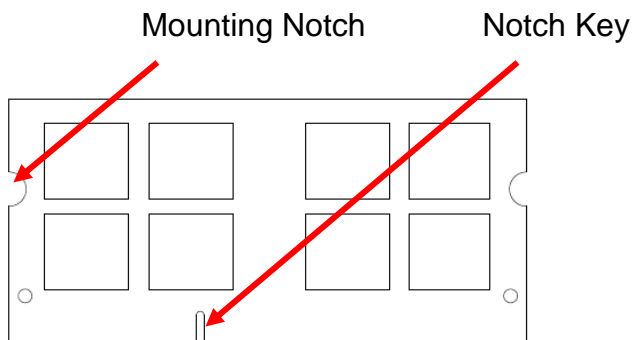

**260-pin DDR4 SODIMM**

- To remove SODIMM modules, simultaneously push the two ejector tabs outward, then pull out the SODIMM module.



### **Note:**

- (1) Please do not change any DDR4 SDRAM parameter in BIOS setup to increase your system's performance without acquiring technical information in advance.
- (2) Static electricity can damage the electronic components of the computer or optional boards. Before proceeding, ensure that you are discharged of static electricity by briefly touching a grounded metal object.

## 2.3 Connector List

You can configure your board to match the needs of your application by setting jumpers. A jumper is the simplest kind of electric switch.

It consists of two metal pins and a small metal clip (often protected by a plastic cover) that slides over the pins to connect them. To “close” a jumper you connect the pins with the clip. To “open” a jumper you remove the clip. Sometimes a jumper will have three pins, labeled 1, 2, and 3. In this case, you would connect either two pins.

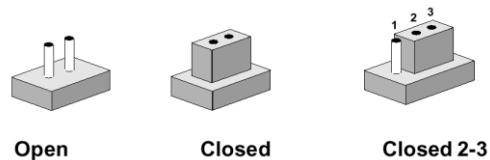

The jumper settings are schematically depicted in this manual as follows:



A pair of needle-nose pliers may be helpful when working with jumpers.

Connectors on the board are linked to external devices such as hard disk drives, a keyboard, or floppy drives. In addition, the board has a number of jumpers that allow you to configure your system to suit your application.

If you have any doubts about the best hardware configuration for your application, contact your local distributor or sales representative before you make any changes.

The following tables list the function of each of the board's jumpers and connectors.

### Connectors

Label	Function	Note
<b>BIOS_SPI1</b>	(Reserved for BIOS programming)	5 x 2 header, pitch 2.00mm
<b>CN1A</b>	COM Express connector 1	
<b>CN1B</b>	COM Express connector 2	
<b>SODIMM1</b>	260-pin DDR4 SDRAM DIMM socket	
<b>SODIMM2</b>	260-pin DDR4 SDRAM DIMM socket	
<b>SW1</b>	AT/ATX mode selector	

## 2.4 Setting Jumpers & Connectors

### 2.4.1 AT/ATX mode selector (SW1)

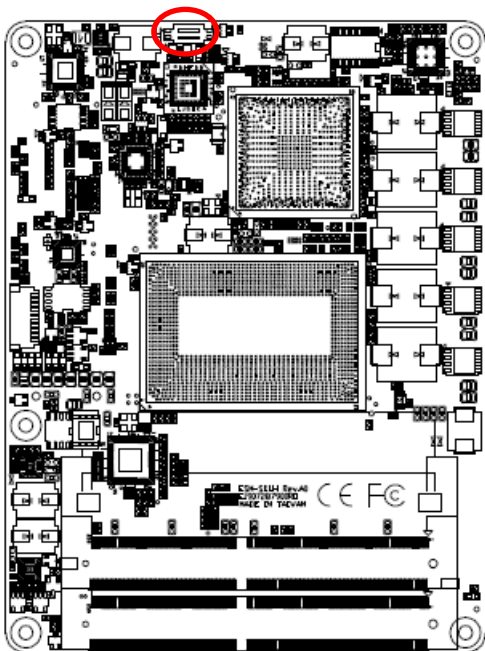

AT/ATX mode



AT mode\*

OFF	1	⇨	ON
	2		

ATX mode

OFF	1	⇦	ON
	2		

\*Default

#### 2.4.1.1 Signal Description –AT/ATX mode selection

AT/ATX mode	Description
<p>AT mode</p>	Auto-power on, no need to press Power button to enable power on/off
<p>ATX mode</p>	Press the power button to enable power on/off

2.4.2 COM Express Connector 1 (CN1A)

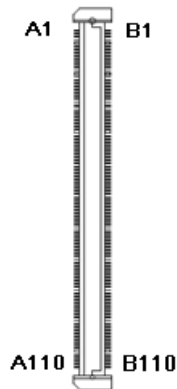
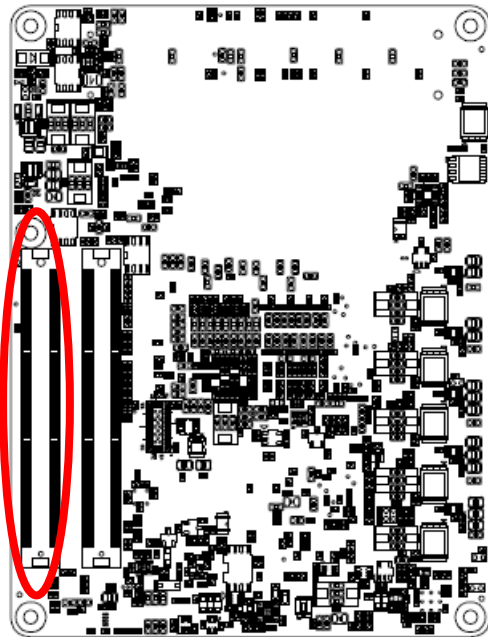

Signal	PIN	PIN	Signal
GND	A1	B1	GND
GBE0_MDI3-	A2	B2	GBE0_ACT#
GBE0_MDI3+	A3	B3	LPC_FRAME#
GBE0_LINK100#	A4	B4	LPC_AD0
GBE0_LINK1000#	A5	B5	LPC_AD1
GBE0_MDI2-	A6	B6	LPC_AD2
GBE0_MDI2+	A7	B7	LPC_AD3
GBE0_LINK#	A8	B8	NC
GBE0_MDI1-	A9	B9	NC
GBE0_MDI1+	A10	B10	LPC_CLK
GND	A11	B11	GND
GBE0_MDI0-	A12	B12	PWRBTN#
GBE0_MDI0+	A13	B13	SMB_CK
GBE0_CTREF	A14	B14	SMB_DAT
SUS_S3#	A15	B15	SMB_ALERT#
SATA0_TX+	A16	B16	SATA1_TX+
SATA0_TX-	A17	B17	SATA1_TX-
SUS_S4#	A18	B18	SUS_STAT#
SATA0_RX+	A19	B19	SATA1_RX+
SATA0_RX-	A20	B20	SATA1_RX-
GND	A21	B21	GND
SATA2_TX+	A22	B22	SATA3_TX+
SATA2_TX-	A23	B23	SATA3_TX-
SUS_S5#	A24	B24	PWR_OK
SATA2_RX+	A25	B25	SATA3_RX+
SATA2_RX-	A26	B26	SATA3_RX-
BATLOW#	A27	B27	WDT
(S)ATA_ACT#	A28	B28	NC
AC/HDA_SYNC	A29	B29	AC/HDA_SDIN1
AC/HDA_RST#	A30	B30	AC/HDA_SDIN0

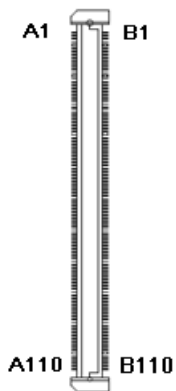
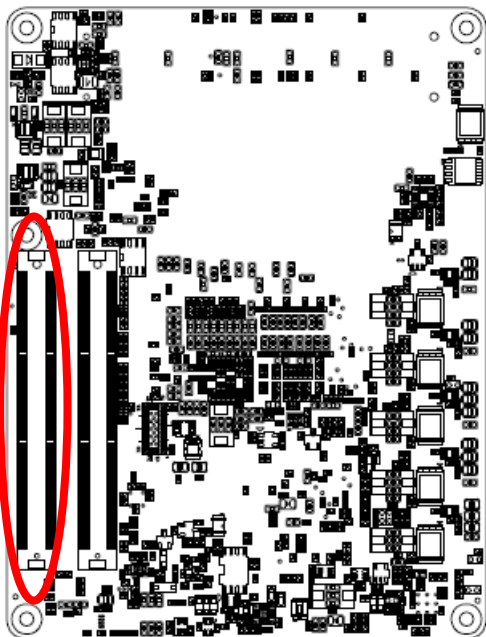

Signal	PIN	PIN	Signal
GND	A31	B31	GND
AC/HDA_BITCLK	A32	B32	SPKR
AC/HDA_SDOOUT	A33	B33	I2C_CK
BIOS_DIS0#	A34	B34	I2C_DAT
THRMTRIP#	A35	B35	THRM#
USB6-	A36	B36	USB7-
USB6+	A37	B37	USB7+
USB_6_7_OC#	A38	B38	USB_4_5_OC#
USB4-	A39	B39	USB5-
USB4+	A40	B40	USB5+
GND	A41	B41	GND
USB2-	A42	B42	USB3-
USB2+	A43	B43	USB3+
USB_2_3_OC#	A44	B44	USB_0_1_OC#
USB0-	A45	B45	USB1-
USB0+	A46	B46	USB1+
VCC_RTC	A47	B47	EXCD1_PERST#
EXCD0_PERST#	A48	B48	EXCD1_CPPE#
EXCD0_CPPE#	A49	B49	SYS_RESET#
LPC_SERIRQ	A50	B50	CB_RESET#
GND	A51	B51	GND
PCIE_TX5+	A52	B52	PCIE_RX5+
PCIE_TX5-	A53	B53	PCIE_RX5-
GPI0	A54	B54	GPO1
PCIE_TX4+	A55	B55	PCIE_RX4+
PCIE_TX4-	A56	B56	PCIE_RX4-
GND	A57	B57	GPO2
PCIE_TX3+	A58	B58	PCIE_RX3+
PCIE_TX3-	A59	B59	PCIE_RX3-
GND	A60	B60	GND

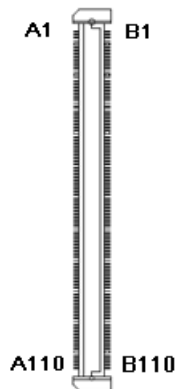
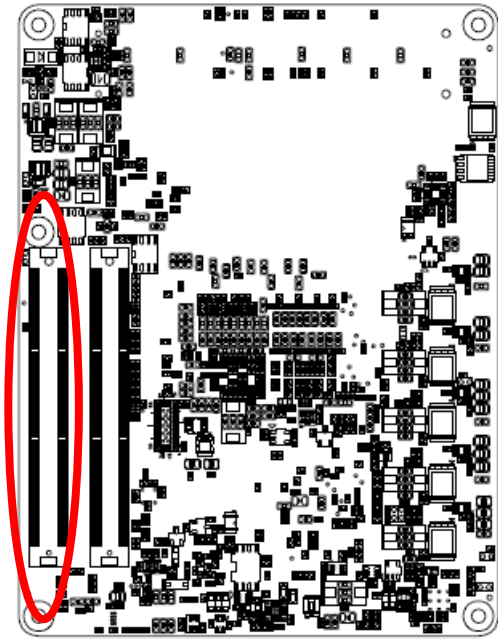

Signal	PIN	PIN	Signal
PCIE_TX2+	A61	B61	PCIE_RX2+
PCIE_TX2-	A62	B62	PCIE_RX2-
GPI1	A63	B63	GPO3
PCIE_TX1+	A64	B64	PCIE_RX1+
PCIE_TX1-	A65	B65	PCIE_RX1-
GND	A66	B66	WAKE0#
GPI2	A67	B67	WAKE1#
PCIE_TX0+	A68	B68	PCIE_RX0+
PCIE_TX0-	A69	B69	PCIE_RX0-
GND	A70	B70	GND
LVDS_A0+	A71	B71	LVDS_B0+
LVDS_A0-	A72	B72	LVDS_B0-
LVDS_A1+	A73	B73	LVDS_B1+
LVDS_A1-	A74	B74	LVDS_B1-
LVDS_A2+	A75	B75	LVDS_B2+
LVDS_A2-	A76	B76	LVDS_B2-
LVDS_VDD_EN	A77	B77	LVDS_B3+
LVDS_A3+	A78	B78	LVDS_B3-
LVDS_A3-	A79	B79	LVDS_BKLT_EN
GND	A80	B80	GND
LVDS_A_CK+	A81	B81	LVDS_B_CK+
LVDS_A_CK-	A82	B82	LVDS_B_CK-
LVDS_I2C_CK	A83	B83	LVDS_BKLT_CTRL
LVDS_I2C_DAT	A84	B84	VCC_5V_SBY_1
GPI3	A85	B85	VCC_5V_SBY_2
RSVD1	A86	B86	VCC_5V_SBY_3
RSVD2	A87	B87	VCC_5V_SBY_4
PCIE_CLK_REF+	A88	B88	BIOS_DIS1#
PCIE_CLK_REF--	A89	B89	VGA_RED
GND	A90	B90	GND

# ESM-SKLA User's Manual

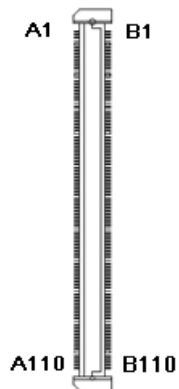
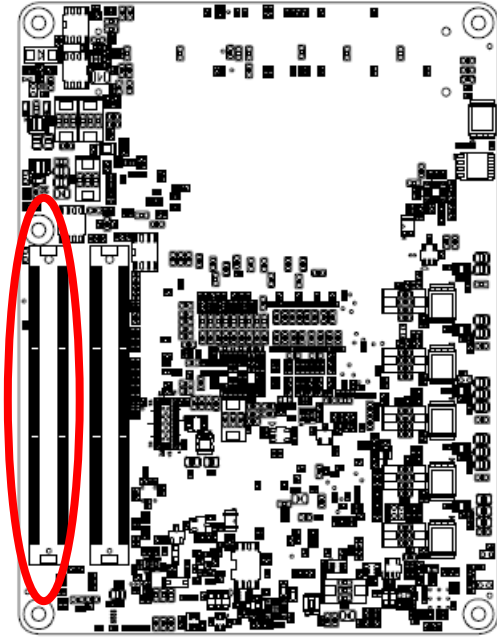

Signal	PIN	PIN	Signal
SPI_POWER	A91	B91	VGA_GRN
SPI_MISO	A92	B92	VGA_BLU
GPO0	A93	B93	VGA_HSYNC
SPI_CLK	A94	B94	VGA_VSYNC
SPI_MOSI	A95	B95	VGA_I2C_CK
PP_TPM	A96	B96	VGA_I2C_DAT
NC	A97	B97	SPI_CS#
SER0_TX	A98	B98	NC
SER0_RX	A99	B99	NC
GND	A100	B100	GND
SER1_TX	A101	B101	FAN_PWMOUT
SER1_RX	A102	B102	FAN_TACHIN
LID#	A103	B103	SLEEP#
VCC	A104	B104	VCC
VCC	A105	B105	VCC
VCC	A106	B106	VCC
VCC	A107	B107	VCC
VCC	A108	B108	VCC
VCC	A109	B109	VCC
GND	A110	B110	GND



### 2.4.2.1 Signal Description – COM Express Connector 1 (CN1A)

#### 2.4.2.1.1 Audio Signals

Signal	Signal Description
AC/HDA_SYNC	AC/HD Audio Sync
AC/HDA_RST#	AC/HD Audio Reset
AC/HDA_SDIN[0:2]	Audio CODEC Serial Data
AC/HDA_BITCLK	AC/HD Audio Clock
AC/HDA_SDOUT	AC/HD Audio Data

#### 2.4.2.1.2 Gigabit Ethernet Signals

Signal	Signal Description																				
GBE0_MD[0:3] +/-	Gigabit Ethernet Controller 0: Media Dependent Interface Differential Pairs 0,1,2,3. The MDI can operate in 1000, 100 and 10 Mbit / sec modes. Some pairs are unused in some modes, per the following:																				
	<table border="1"> <thead> <tr> <th></th> <th>1000B-T</th> <th>100B-T</th> <th>10B-T</th> </tr> </thead> <tbody> <tr> <td>MDI[0] +/-</td> <td>B1_DA+/-</td> <td>TX+/-</td> <td>TX+/-</td> </tr> <tr> <td>MDI[1] +/-</td> <td>B1_DB+/-</td> <td>RX+/-</td> <td>RX+/-</td> </tr> <tr> <td>MDI[2] +/-</td> <td>B1_DC+/-</td> <td>X</td> <td>X</td> </tr> <tr> <td>MDI[3] +/-</td> <td>B1_DD+/-</td> <td>X</td> <td>X</td> </tr> </tbody> </table>		1000B-T	100B-T	10B-T	MDI[0] +/-	B1_DA+/-	TX+/-	TX+/-	MDI[1] +/-	B1_DB+/-	RX+/-	RX+/-	MDI[2] +/-	B1_DC+/-	X	X	MDI[3] +/-	B1_DD+/-	X	X
		1000B-T	100B-T	10B-T																	
	MDI[0] +/-	B1_DA+/-	TX+/-	TX+/-																	
	MDI[1] +/-	B1_DB+/-	RX+/-	RX+/-																	
MDI[2] +/-	B1_DC+/-	X	X																		
MDI[3] +/-	B1_DD+/-	X	X																		
GBE0_ACT#	Gigabit Ethernet Controller 0 activity indicator, active low.																				
GBE0_Link#	Gigabit Ethernet Controller 0 link indicator, active low.																				
GBE0_Link100#	Gigabit Ethernet Controller 0 100 Mbit / sec link indicator, active low.																				
GBE0_Lin1000#	Gigabit Ethernet Controller 0 1000 Mbit / sec link indicator, active low.																				

#### 2.4.2.1.3 PCI Express Signals

Signal	Signal Description
PCIE_TX[0:6] +/-	PCI Express Differential Transmit Pair 0-6
PCIE_RX[0:6] +/-	PCI Express Differential Receive Pair 0-6
PCIE0_CK_REF +/-	Reference clock output for PCI Express lanes 0-6 and for PCI Express Graphics lanes 0-15

## ESM-SKLA User's Manual

### 2.4.2.1.4 Flat Panel LVDS Signals

Signal	Signal Description
LVDS_BKLT_CTRL	Controls panel digital power.
ENBKL#	Controls backlight power enable.
LVDS_I2C_CK	I2C clock output for LVDS display use.
LVDS_I2C_DAT	I2C data line for LVDS display use.
LVDS_A[0:3] +/-	LVDS Channel A differential pairs.
LVDS_B[0:3] +/-	LVDS Channel B differential pairs.
LVDS_VDD_EN	LVDS panel power enables.
LVDS_A_CK +/-	LVDS Channel A differential clock.
LVDS_B_CK +/-	LVDS Channel A differential clock.

### 2.4.2.1.5 LPC Signals

Signal	Signal Description
LPC_FRAME#	LPC frame indicates the start of an LPC cycle
LPC_AD[0:3]	LPC multiplexed address, command and data bus
LPC_DRQ[0:1]#	LPC serial DMA request
LPC_CLK	LPC clock output - 33MHz nominal
LPC_SERIRQ	LPC serial interrupt

### 2.4.2.1.6 Miscellaneous Signals

Signal	Signal Description																																								
SPKR	Output for audio enunciator - the "speaker" in PC-AT systems																																								
BIOS_DIS0# BIOS_DIS1#	<p>Selection straps to determine the BIOS boot device</p> <table border="1"> <thead> <tr> <th>BIOS_DIS1#</th> <th>BIOS_DIS0#</th> <th>Chipset SPI CS1# Destination</th> <th>Chipset SPI CS0# Destination</th> <th>Carrier SPI_CS#</th> <th>SPI Descriptor</th> <th>Bios Entry</th> <th>Ref Line</th> </tr> </thead> <tbody> <tr> <td>1</td> <td>1</td> <td>Module</td> <td>Module</td> <td>High</td> <td>Module</td> <td>SPI0/SPI1</td> <td>0</td> </tr> <tr> <td>1</td> <td>0</td> <td>Module</td> <td>Module</td> <td>High</td> <td>Module</td> <td>Carrier FWH</td> <td>1</td> </tr> <tr> <td>0</td> <td>1</td> <td>Module</td> <td>Carrier</td> <td>SPI0</td> <td>Carrier</td> <td>SPI0/SPI1</td> <td>2</td> </tr> <tr> <td>0</td> <td>0</td> <td>Carrier</td> <td>Module</td> <td>SPI1</td> <td>Module</td> <td>SPI0/SPI1</td> <td>3</td> </tr> </tbody> </table>	BIOS_DIS1#	BIOS_DIS0#	Chipset SPI CS1# Destination	Chipset SPI CS0# Destination	Carrier SPI_CS#	SPI Descriptor	Bios Entry	Ref Line	1	1	Module	Module	High	Module	SPI0/SPI1	0	1	0	Module	Module	High	Module	Carrier FWH	1	0	1	Module	Carrier	SPI0	Carrier	SPI0/SPI1	2	0	0	Carrier	Module	SPI1	Module	SPI0/SPI1	3
BIOS_DIS1#	BIOS_DIS0#	Chipset SPI CS1# Destination	Chipset SPI CS0# Destination	Carrier SPI_CS#	SPI Descriptor	Bios Entry	Ref Line																																		
1	1	Module	Module	High	Module	SPI0/SPI1	0																																		
1	0	Module	Module	High	Module	Carrier FWH	1																																		
0	1	Module	Carrier	SPI0	Carrier	SPI0/SPI1	2																																		
0	0	Carrier	Module	SPI1	Module	SPI0/SPI1	3																																		

### 2.4.2.1.7 GPIO Signals

Signal	Signal Description
GPI[0:4]	General purpose input pins.
GPO[0:4]	General purpose output pins.

2.4.2.1.8 Power Signals

Signal	Signal Description
VCC_5V_SBY	Standby power input: +5.0V nominal. See Electrical Specifications for allowable input range. If VCC5_SBY is used, all available VCC_5V_SBY pins on the connector(s) must be used. Only used for standby and suspend functions. May be left unconnected if these functions are not used in the system design.
VCC_RTC	Real-time clock circuit-power input. Nominally +3.0V.

2.4.2.1.9 Power & System Management Signals

Signal	Signal Description
SUS_S3#	Indicates system is in Suspend to RAM state. Active low output.
SUS_S4#	Indicates system is in Suspend to Disk state. Active low output.
SUS_S5#	Indicates system is in Soft Off state.
BATLOW#	Indicates that external battery is low
PWRBTN#	Power button to bring system out of S5 (soft off), active on rising edge.
SMB_CK	System Management Bus bidirectional clock line.
SMB_DTA	System Management Bus bidirectional data line.
SMB_ALERT#	System Management Bus Alert - input can be used to generate an SMI# (System Management Interrupt) or to wake the system.
SUS_STAT#	Indicates imminent suspend operation.
PWR_OK	Power OK from main power supply
SYS_RESET#	Reset button input. Active low input.
WAKE0#	PCI Express wake up signal.
WAKE1#	General purpose wake up signal.

## ESM-SKLA User's Manual

### 2.4.2.1.10 SATA Signals

Signal	Signal Description
SATA[0:3]_TX +/-	Serial ATA Channel 0-3 transmit differential pair.
SATA[0:3]_RX +/-	Serial ATA Channel 0-3 receive differential pair.
ATA_ACT#	ATA (parallel and serial) activity indicator, active low.

### 2.4.2.1.11 VGA Signals

Signal	Signal Description
VGA_RED	Red for monitor. Analog DAC output.
VGA_GRN	Green for monitor. Analog DAC output.
VGA_BLU	Blue for monitor. Analog DAC output.
VGA_HSYNC	Horizontal sync output to VGA monitor
VGA_VSYNC	Vertical sync output to VGA monitor
VGA_I <sup>2</sup> C_CLK	DDC clock line (I2C port dedicated to identify VGA monitor capabilities)
VGA_I <sup>2</sup> C_DAT	DDC data line.

### 2.4.2.1.12 USB Signals

Signal	Signal Description
USB[0:7] +/-	USB differential pairs, channels 0 through 7
USB_0_1_OC#	USB over-current sense, USB channels 0 and 1
USB_2_3_OC#	USB over-current sense, USB channels 2 and 3
USB_4_5_OC#	USB over-current sense, USB channels 4 and 5
USB_6_7_OC#	USB over-current sense, USB channels 6 and 7

### 2.4.2.1.13 I2C Signals

Signal	Signal Description
I2C_CLK	General purpose I2C port clock output.
I2C_DAT	General purpose I2C port data I/O line.

### 2.4.2.1.14 COM.0 Pins Signals

Signal	Signal Description
SER0/1_TX	TTL level outputs from the Module.
SER0/1_RX	TTL level inputs from the Module.

### 2.4.3 COM Express Connector 2 (CN1B)

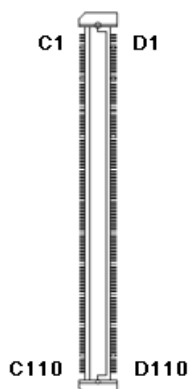
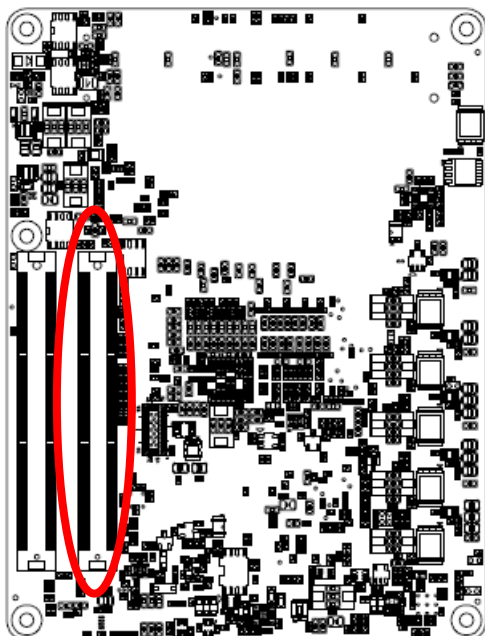

Signal	PIN	PIN	Signal
GND	C1	D1	GND
GND	C2	D2	GND
USB_SSRX0-	C3	D3	USB_SSTX0-
USB_SSRX0+	C4	D4	USB_SSTX0+
GND	C5	D5	GND
USB_SSRX1-	C6	D6	USB_SSTX1-
USB_SSRX1+	C7	D7	USB_SSTX1+
GND	C8	D8	GND
USB_SSRX2-	C9	D9	USB_SSTX2-
USB_SSRX2+	C10	D10	USB_SSTX2+
GND	C11	D11	GND
USB_SSRX3-	C12	D12	USB_SSTX3-
USB_SSRX3+	C13	D13	USB_SSTX3+
GND	C14	D14	GND
NC	C15	D15	DDI1_CTRLCLK_AUX+
NC	C16	D16	DDI1_CTRLDATA_AUX-
RSVD5	C17	D17	NC
RSVD6	C18	D18	NC
PCIE_RX6+	C19	D19	PCIE_TX6+
PCIE_RX6-	C20	D20	PCIE_TX6-
GND	C21	D21	GND
PCIE_RX7+	C22	D22	PCIE_TX7+
PCIE_RX7-	C23	D23	PCIE_TX7-
DDI1_HPD	C24	D24	NC
NC	C25	D25	NC
NC	C26	D26	DDI1_PAIR0+
RSVD7	C27	D27	DDI1_PAIR0-
NC	C28	D28	NC
NC	C29	D29	DDI1_PAIR1+
NC	C30	D30	DDI1_PAIR1-

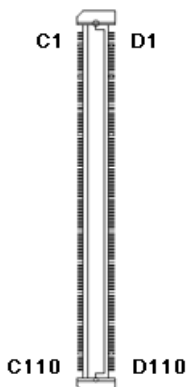
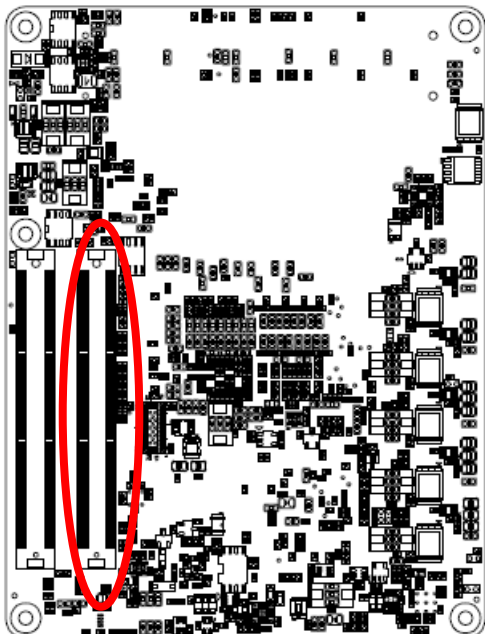

Signal	PIN	PIN	Signal
GND	C31	D31	GND
DDI2_CTRLCLK_AUX+	C32	D32	DDI1_PAIR2+
DDI2_CTRLDATA_AUX-	C33	D33	DDI1_PAIR2-
DDI2_DDC_AUX_SEL	C34	D34	DDI1_DDC_AUX_SEL
NC	C35	D35	NC
DDI3_CTRLCLK_AUX+	C36	D36	DDI1_PAIR3+
DDI3_CTRLDATA_AUX-	C37	D37	DDI1_PAIR3-
DDI3_DDC_AUX_SEL	C38	D38	NC
DDI3_PAIR0+	C39	D39	DDI2_PAIR0+
DDI3_PAIR0-	C40	D40	DDI2_PAIR0-
GND	C41	D41	GND
DDI3_PAIR1+	C42	D42	DDI2_PAIR1+
DDI3_PAIR1-	C43	D43	DDI2_PAIR1-
DDI3_HPD	C44	D44	DDI2_HPD
NC	C45	D45	NC
DDI3_PAIR2+	C46	D46	DDI2_PAIR2+
DDI3_PAIR2-	C47	D47	DDI2_PAIR2-
NC	C48	D48	NC
DDI3_PAIR3+	C49	D49	DDI2_PAIR3+
DDI3_PAIR3-	C50	D50	DDI2_PAIR3-
GND	C51	D51	GND
PEG_RX0+	C52	D52	PEG_TX0+
PEG_RX0-	C53	D53	PEG_TX0-
TYPE0#	C54	D54	PEG_LANE_RV#
PEG_RX1+	C55	D55	PEG_TX1+
PEG_RX1-	C56	D56	PEG_TX1-
TYPE1#	C57	D57	TYPE2#
PEG_RX2+	C58	D58	PEG_TX2+
PEG_RX2-	C59	D59	PEG_TX2-
GND	C60	D60	GND

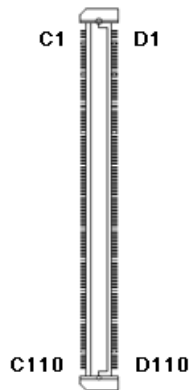
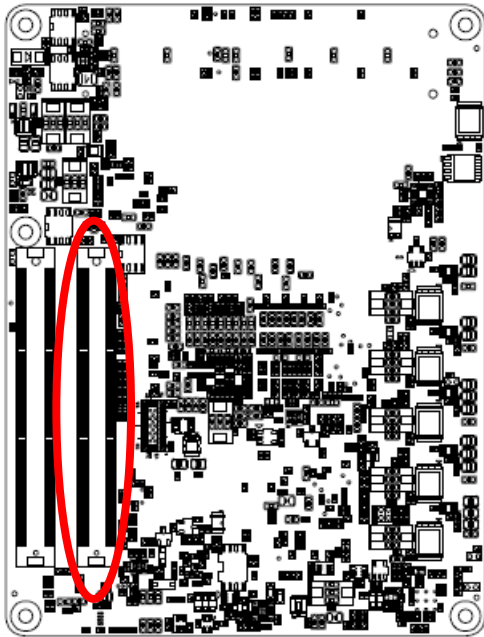

Signal	PIN	PIN	Signal
PEG_RX3+	C61	D61	PEG_TX3+
PEG_RX3-	C62	D62	PEG_TX3-
NC	C63	D63	NC
NC	C64	D64	NC-
PEG_RX4+	C65	D65	PEG_TX4+
PEG_RX4-	C66	D66	PEG_TX4-
NC	C67	D67	GND
PEG_RX5+	C68	D68	PEG_TX5+
PEG_RX5-	C69	D69	PEG_TX5-
GND	C70	D70	GND
PEG_RX6+	C71	D71	PEG_TX6+
PEG_RX6-	C72	D72	PEG_TX6-
GND	C73	D73	GND
PEG_RX7+	C74	D74	PEG_TX7+
PEG_RX7-	C75	D75	PEG_TX7-
GND	C76	D76	GND
NC	C77	D77	NC
PEG_RX8+	C78	D78	PEG_TX8+
PEG_RX8-	C79	D79	PEG_TX8-
GND	C80	D80	GND
PEG_RX9+	C81	D81	PEG_TX9+
PEG_RX9-	C82	D82	PEG_TX9-
NC	C83	D83	NC
GND	C84	D84	GND
PEG_RX10+	C85	D85	PEG_TX10+
PEG_RX10-	C86	D86	PEG_TX10-
GND	C87	D87	GND
PEG_RX11+	C88	D88	PEG_TX11+
PEG_RX11-	C89	D89	PEG_TX11-
GND	C90	D90	GND

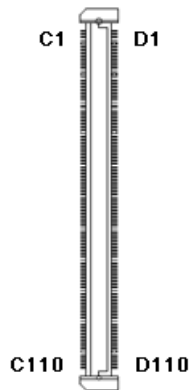
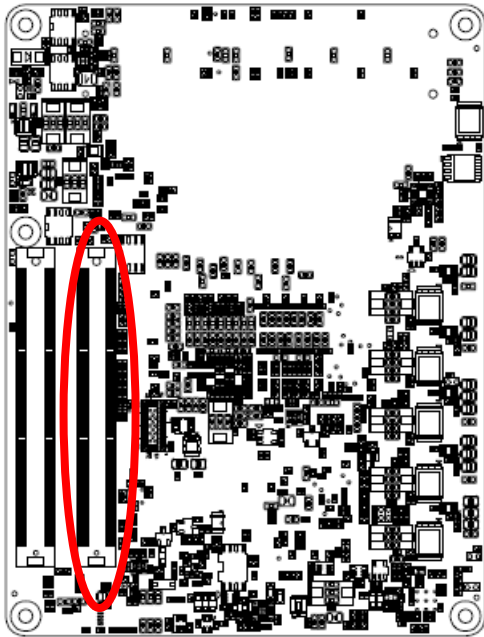

Signal	PIN	PIN	Signal
PEG_RX12+	C91	D91	PEG_TX12+
PEG_RX12-	C92	D92	PEG_TX12-
GND	C93	D93	GND
PEG_RX13+	C94	D94	PEG_TX13+
PEG_RX13-	C95	D95	PEG_TX13-
GND	C96	D96	GND
NC	C97	D97	NC
PEG_RX14+	C98	D98	PEG_TX14+
PEG_RX14-	C99	D99	PEG_TX14-
GND	C100	D100	GND
PEG_RX15+	C101	D101	PEG_TX15+
PEG_RX15-	C102	D102	PEG_TX15-
GND	C103	D103	GND
VCC	C104	D104	VCC
VCC	C105	D105	VCC
VCC	C106	D106	VCC
VCC	C107	D107	VCC
VCC	C108	D108	VCC
VCC	C109	D109	VCC
GND	C110	D110	GND



### 2.4.3.1 Signal Description – COM Express Connector 2 (CN1B)

#### 2.4.3.1.1 USB3.0 Signals

Signal	Signal Description
USB_SSTX[0:3]+ USB_SSTX[0:3]-	Additional transmit signal differential pairs for the SuperSpeed USB data path.
USB_SSRX[0:3]+ USB_SSRX[0:3]-	Additional receive signal differential pairs for the SuperSpeed USB data path.

#### 2.4.3.1.2 PEG Signals

Signal	Signal Description
PEG_TX[ 0:15]+ PEG_TX[ 0:15]-	PCI Express Graphics transmit differential paris.
PEG_RX[ 0:15]+ PEG_RX[ 0:15]-	PCI Express Graphics recevie differential paris.
PEG_LANE_RV#	PCI Express Graphics lane reversal input strap. Pull low on the Carrier board to reverse lane order.

#### 2.4.3.1.3 DDI Signals

Signal	Signal Description
DDI[1:3]_PAIR[0:3]+ DDI[1:3]_PAIR [0:3]-	Digital Display Interface 1 to 3 Pair[0:3] differential pairs
DDI[1:3]_DDC_AUX_SEL	Selects the function of DDI[1:3]_CTRLCLK_AUX+ and DDI[1:3]_CTRLDATA_AUX-. If this input is floating the AUX pair is used for the DP AUX+/- signals. If pulled-high the AUX pair contains the CRTLCLK and CTRLDATA signals.
DDI[1:3]_CTRLCLK_AUX+	DP AUX+function if DDI[1:3]_DDC_AUX_SEL is no connect HDMI/DVI 12C CTRLCLK if DDI[1:3]_DDC_AUX_SEL is pulled high
DDI[1:3]_CTRLDATA_AUX-	DP AUX-function if DDI[1:3]_DDC_AUX_SEL is no connect HDMI/DVI 12C CTRLDATA if DDI[1:3]_DDC_AUX_SEL is pulled high
DDI[1:3]_HPD	Digital Display Interface Hot-Plug Detect

# 3. BIOS Setup

---

### 3.1 Introduction

The BIOS setup program allows users to modify the basic system configuration. In this following chapter will describe how to access the BIOS setup program and the configuration options that may be changed.

### 3.2 Starting Setup

AMI BIOS™ is immediately activated when you first power on the computer. The BIOS reads the system information contained in the NVRAM and begins the process of checking out the system and configuring it. When it finishes, the BIOS will seek an operating system on one of the disks and then launch and turn control over to the operating system.

While the BIOS is in control, the Setup program can be activated in one of two ways:

By pressing <F2> or <Del> immediately after switching the system on, or

By pressing the <F2> or <Del> key when the following message appears briefly at the left-top of the screen during the POST (Power On Self Test).

**Press <F2> or <Del> to enter SETUP**

If the message disappears before you respond and you still wish to enter Setup, restart the system to try again by turning it OFF then ON or pressing the "RESET" button on the system case. You may also restart by simultaneously pressing <Ctrl>, <Alt>, and <Delete> keys.

### 3.3 Using Setup

In general, you use the arrow keys to highlight items, press <Enter> to select, use the PageUp and PageDown keys to change entries, press <F1> for help and press <Esc> to quit. The following table provides more detail about how to navigate in the Setup program using the keyboard.

Button	Description
↑	Move to previous item
↓	Move to next item
←	Move to the item in the left hand
→	Move to the item in the right hand
Esc key	Main Menu -- Quit and not save changes into NVRAM Status Page Setup Menu and Option Page Setup Menu -- Exit current page and return to Main Menu
+ key	Increase the numeric value or make changes
- key	Decrease the numeric value or make changes
F1 key	General help, only for Status Page Setup Menu and Option Page Setup Menu
F2 key	Previous Values
F3 key	Optimized defaults
F4 key	Save & Exit Setup

- **Navigating Through The Menu Bar**

Use the left and right arrow keys to choose the menu you want to be in.



**Note:** Some of the navigation keys differ from one screen to another.

- **To Display a Sub Menu**

Use the arrow keys to move the cursor to the sub menu you want. Then press <Enter>. A “➤” pointer marks all sub menus.

### 3.4 Getting Help

Press F1 to pop up a small help window that describes the appropriate keys to use and the possible selections for the highlighted item. To exit the Help Window press <Esc> or the F1 key again.

### 3.5 In Case of Problems

If, after making and saving system changes with Setup, you discover that your computer no longer is able to boot, the BIOS supports an override to the NVRAM settings which resets your system to its defaults.

The best advice is to only alter settings which you thoroughly understand. To this end, we strongly recommend that you avoid making any changes to the chipset defaults. These defaults have been carefully chosen by both your systems manufacturer to provide the absolute maximum performance and reliability. Even a seemingly small change to the chipset setup has the potential for causing you to use the override.

### 3.6 BIOS setup

Once you enter the Aptio Setup Utility, the Main Menu will appear on the screen. The Main Menu allows you to select from several setup functions and exit choices. Use the arrow keys to select among the items and press <Enter> to accept and enter the sub-menu.

#### 3.6.1 Main Menu

This section allows you to record some basic hardware configurations in your computer and set the system clock.

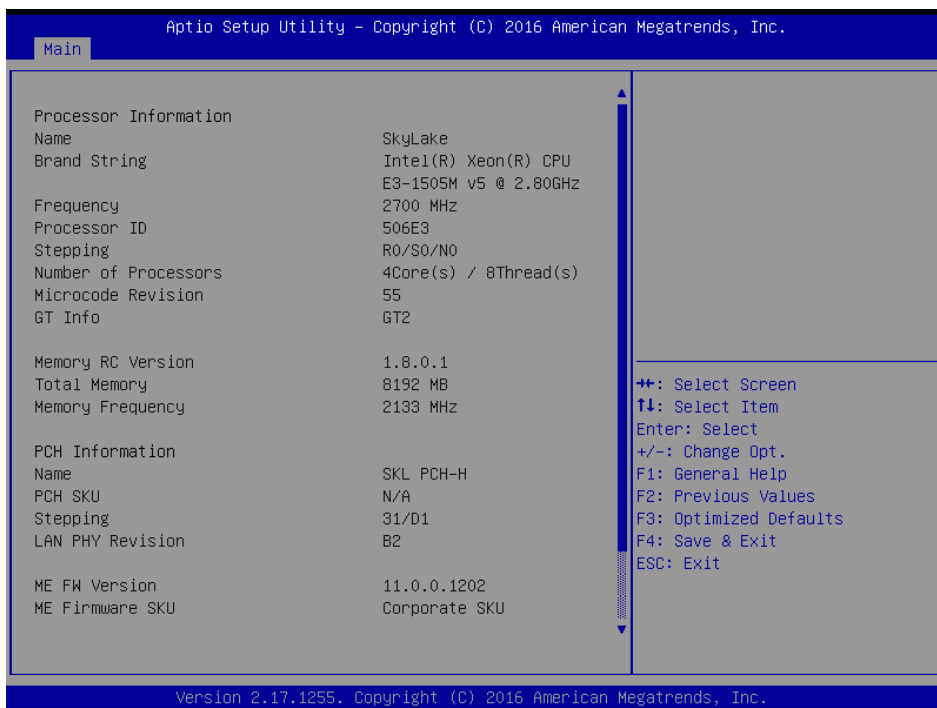

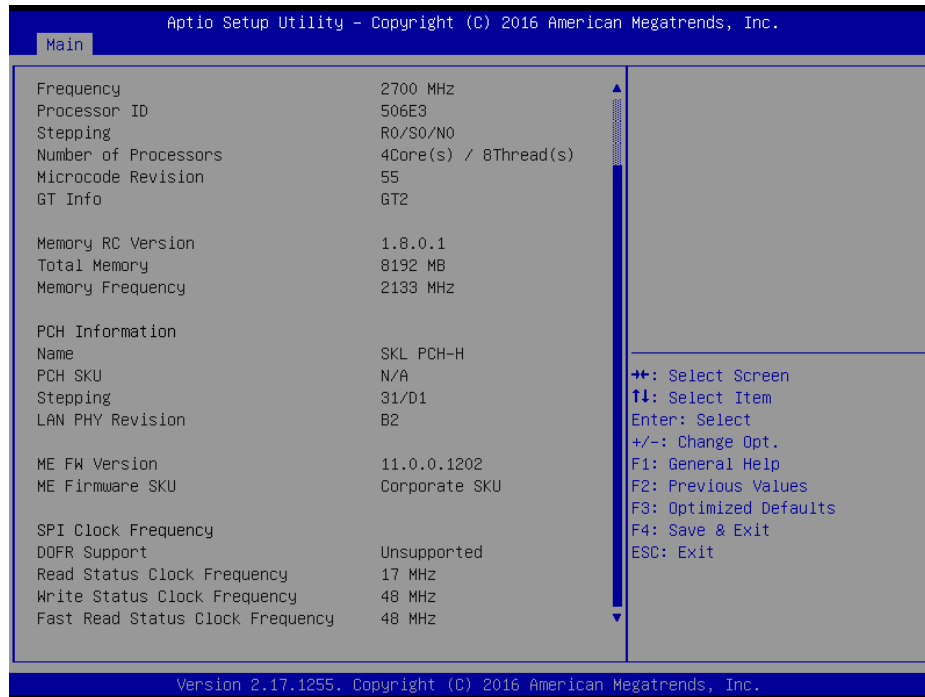

### 3.6.1.1 System Language

This option allows choosing the system default language.

### 3.6.1.2 System Date

Use the system date option to set the system date. Manually enter the day, month and year.

### 3.6.1.3 System Time

Use the system time option to set the system time. Manually enter the hours, minutes and seconds.



**Note:** The BIOS setup screens shown in this chapter are for reference purposes only, and may not exactly match what you see on your screen.

Visit the Avalue website ([www.avalue.com.tw](http://www.avalue.com.tw)) to download the latest product and BIOS information.

# ESM-SKLA User's Manual

## 3.6.2 Advanced Menu

This section allows you to configure your CPU and other system devices for basic operation through the following sub-menus.

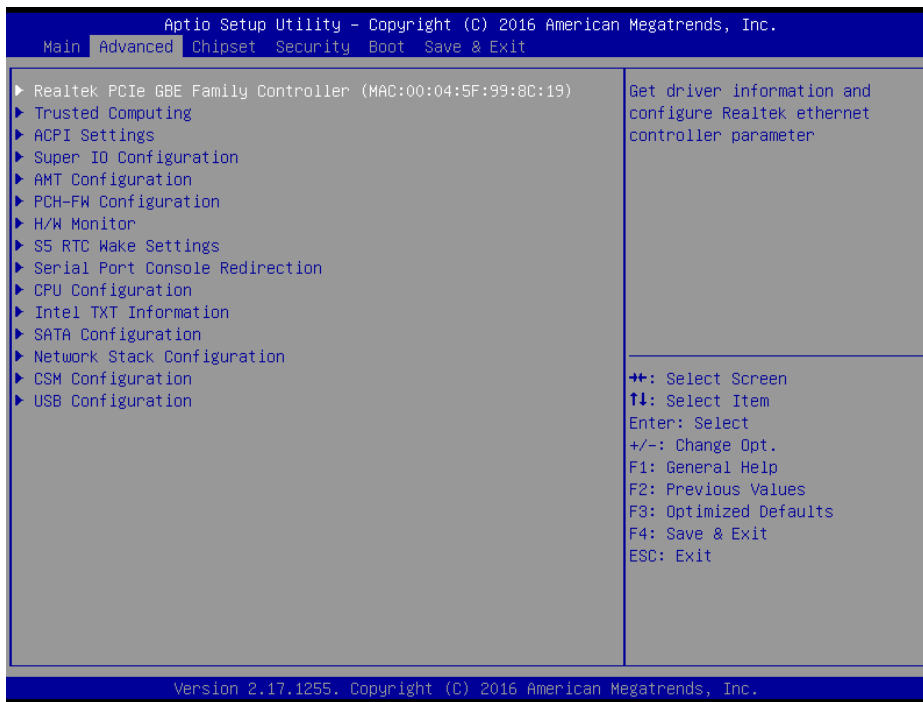

### 3.6.2.1 Driver Health

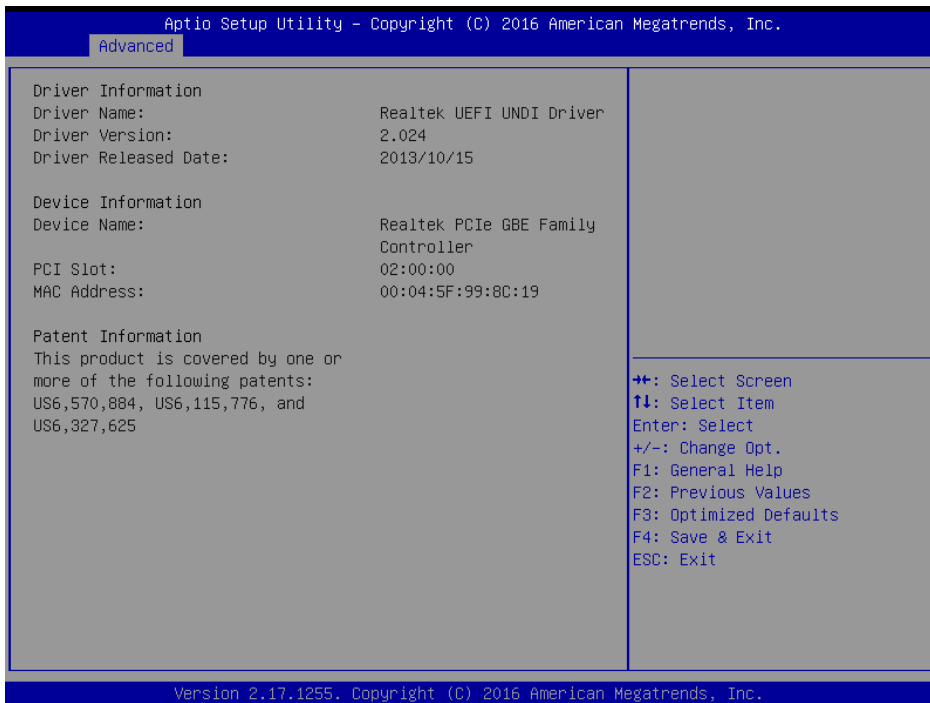



3.6.2.2 Trusted Computing

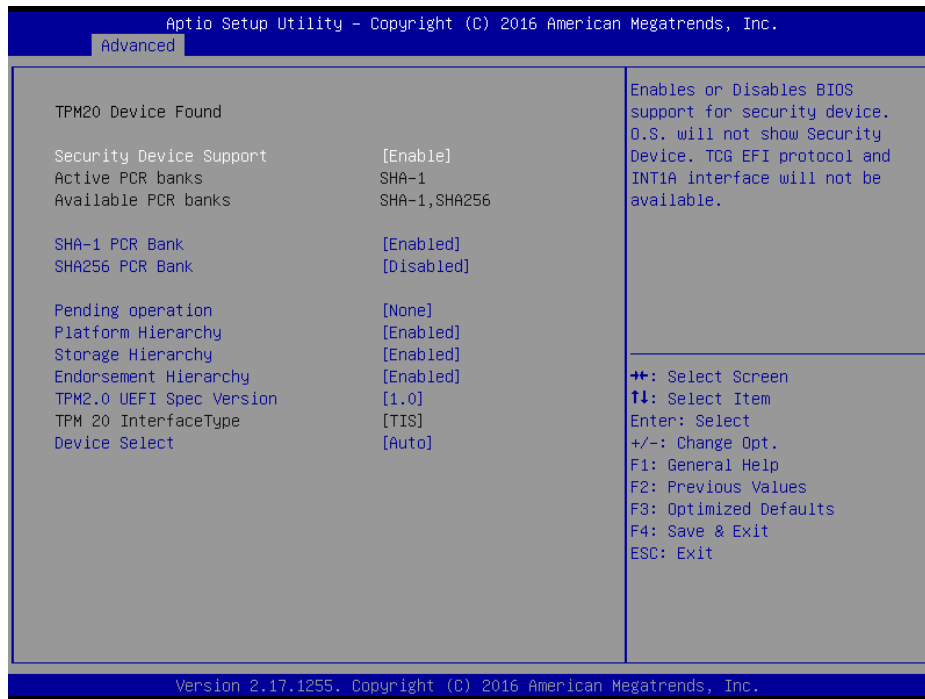

Item	Options	Description
<b>Security Device Support</b>	Disable, Enable[Default]	Enables or Disables BIOS support for security device. O.S. will not show Security Device. TCG EFI protocol and INT1A interface will not be available.
<b>SHA-1 PCR Bank</b>	Disabled Enabled[Default],	Enable or Disable SHA-1 PCR Bank.
<b>SHA256 PCR Bank</b>	Disabled[Default], Enabled	Enable or Disable SHA256 PCR Bank.
<b>Pending operation</b>	None[Default], TPM Clear	Schedule an Operation for the Security Device. NOTE: Your Computer will reboot during restart in order to change State of Security Device.
<b>Platform Hierarchy</b>	Disabled Enabled[Default],	Enable or Disable Platform Hierarchy.
<b>Storage Hierarchy</b>	Disabled Enabled[Default],	Enable or Disable Storage Hierarchy.
<b>Endorsement Hierarchy</b>	Disabled Enabled[Default],	Enable or Disable Endorsement Hierarchy.
<b>TPM2.0 UEFI Spec Version</b>	1.0[Default], 1.x	Select the TCG2 Spec Version Support, 1.0: the Compatible mode for Win8/Win10, 1.x: For TCG2 never spec for Win10.
<b>Device Select</b>	Auto[Default],	TPM 1.2 will restrict support to TPM 1.2 devices, TPM 2.0 will restrict support to TPM 2.0 devices, Auto will support both with the default set to TPM 2.0 devices if not found, TPM 1.2 devices will be enumerated.

3.6.2.3 APCI Settings

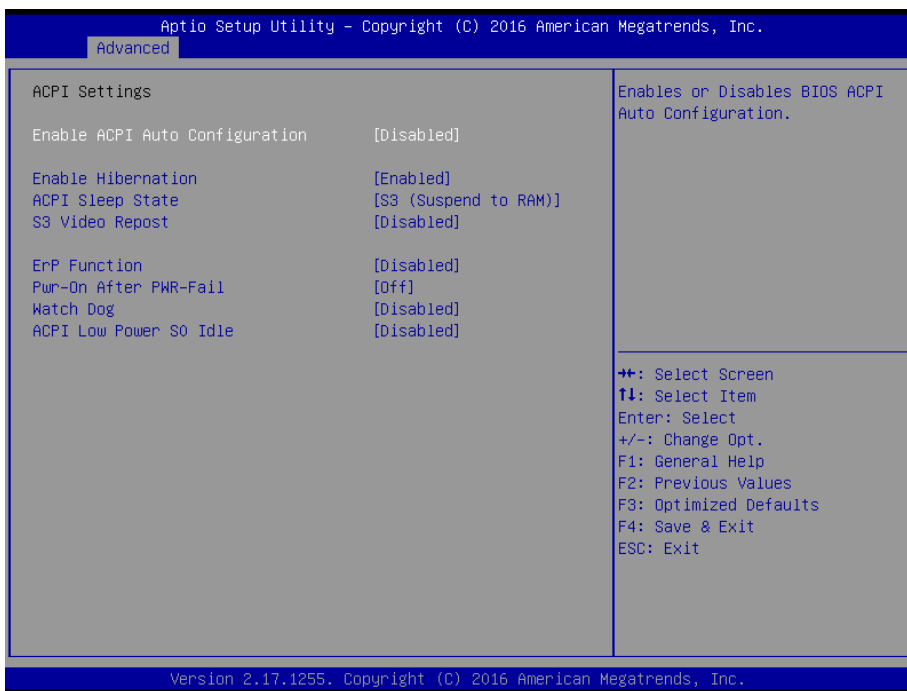

Item	Options	Description
<b>Enable ACPI Auto Configuration</b>	Disabled <b>[Default]</b> , Enabled	Enables or Disables BIOS ACPI Auto Configuration.
<b>Enable Hibernation</b>	Disabled Enabled <b>[Default]</b> ,	Enables or Disables System ability to Hibernate (OS/S4 Sleep State). This option may be not effective with some OS.
<b>ACPI Sleep State</b>	Suspend Disabled, S3 (Suspend to RAM) <b>[Default]</b>	Select the highest ACPI sleep state the system will enter when the SUSPEND button is pressed.
<b>S3 Video Repost</b>	Disabled <b>[Default]</b> , Enabled	Enable or Disable S3 Video Repost.
<b>ErP Function</b>	Disabled <b>[Default]</b> , Enabled	ErP Function (Deep S5).
<b>Pwr-On After PWR-Fail</b>	Off <b>[Default]</b> On Last state	Select the power station after power failure.
<b>Watch Dog</b>	Disabled <b>[Default]</b> , 30 sec 40 sec 50 sec 1 min 2 min 10 min 30 min	Select Watch Dog Timer (WDT) Mode.

<b>ACPI Low Power S0 Idle</b>	Disabled[ <b>Default</b> ], Enabled	Enable or Disable ACPI Low Power S0 Idle Support.
-------------------------------	--	---

### 3.6.2.4 IT8528 Super IO Configuration

You can use this item to set up or change the IT8528 Super IO configuration for serial ports.

Please refer to 3.6.2.4.1~ 3.6.2.4.2 for more information.



Item	Description
<b>Serial Port 1 Configuration</b>	Set Parameters of Serial Port 1 (COMA).
<b>Serial Port 2 Configuration</b>	Set Parameters of Serial Port 2 (COMB).

3.6.2.4.1 Serial Port 1 Configuration

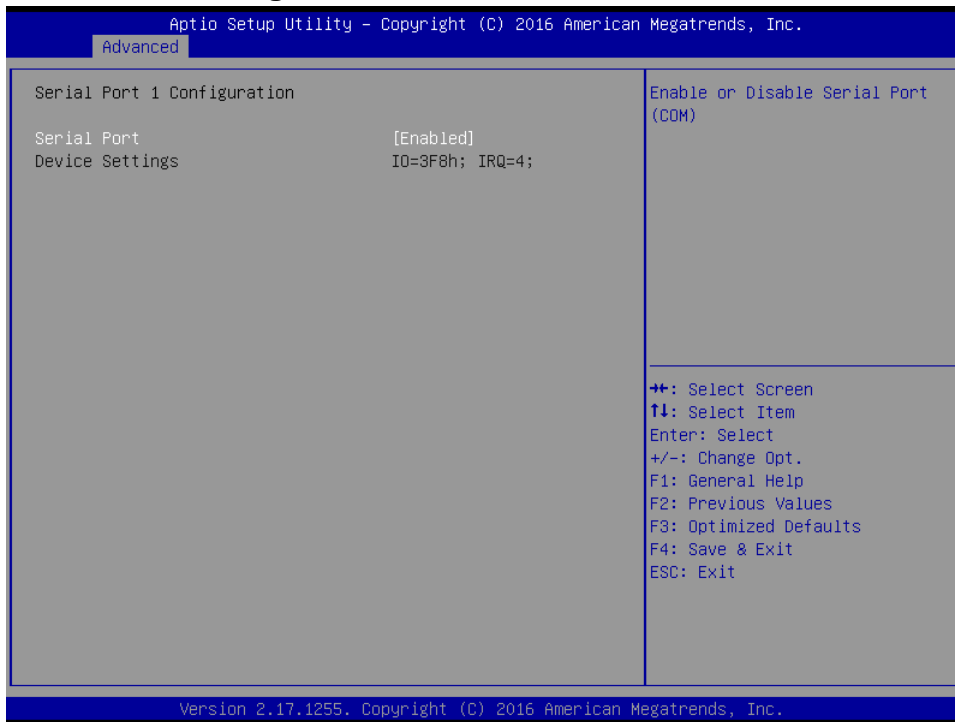

Item	Option	Description
Serial Port	Enabled[Default], Disabled	Enable or Disable Serial Port (COM).

**Note:**

Only TX / RX signal, not a full-featured UART function.

3.6.2.4.2 Serial Port 2 Configuration

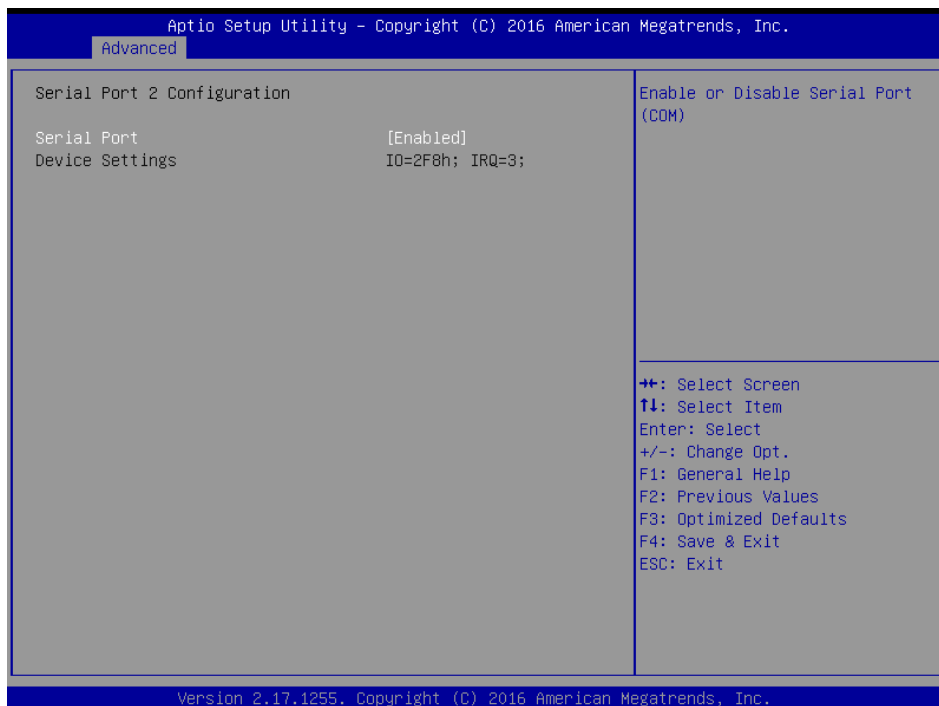

Item	Option	Description
Serial Port	Enabled[Default], Disabled	Enable or Disable Serial Port (COM).

**Note:**

Only TX / RX signal, not a full-featured UART function.

### 3.6.2.5 AMT Configuration

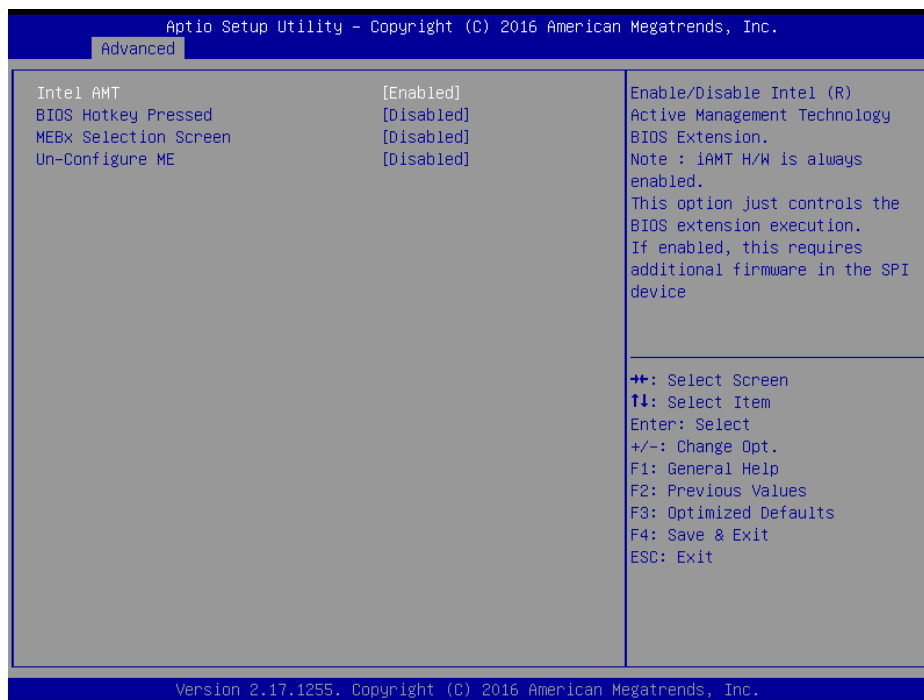

Item	Options	Description
Intel AMT	Disabled Enabled[Default],	Enable/Disable Intel® Active Management Technology BIOS Extension. Note: iAMT H/W is always enabled. This option just controls the BIOS extension execution. If enabled, this requires additional firmware in the SPI device.
BIOS Hotkey Pressed	Disabled[Default] Enabled,	OEMFlag Bit 1: Enable/Disable BIOS hotkey press.
MEBx Selection Screen	Disabled[Default] Enabled,	OEMFlag Bit 2: Enable/Disable MEBx selection screen.
Un-Configure ME	Disabled[Default] Enabled,	OEMFlag Bit 15: Un-Configure ME without password.

3.6.2.6 PCH-FW Configuration



Item	Options	Description
<b>fTPM Switch Selection</b>	GPDMA Work-Around[Default], MSFT QFE Solution	Select the desired fTPM solution to be used.
<b>TPM Device Selection</b>	dTPM 1.2[Default], PTT	Selects TPM device: PTT or dTPM. PTT – Enables PTT in SkuMgr dTPM 1.2 – Disables PTT in SkuMgr Warning! PTT/dTPM will be disabled and all data saved on it will be lost.

### 3.6.2.6.1 Firmware Update Configuration

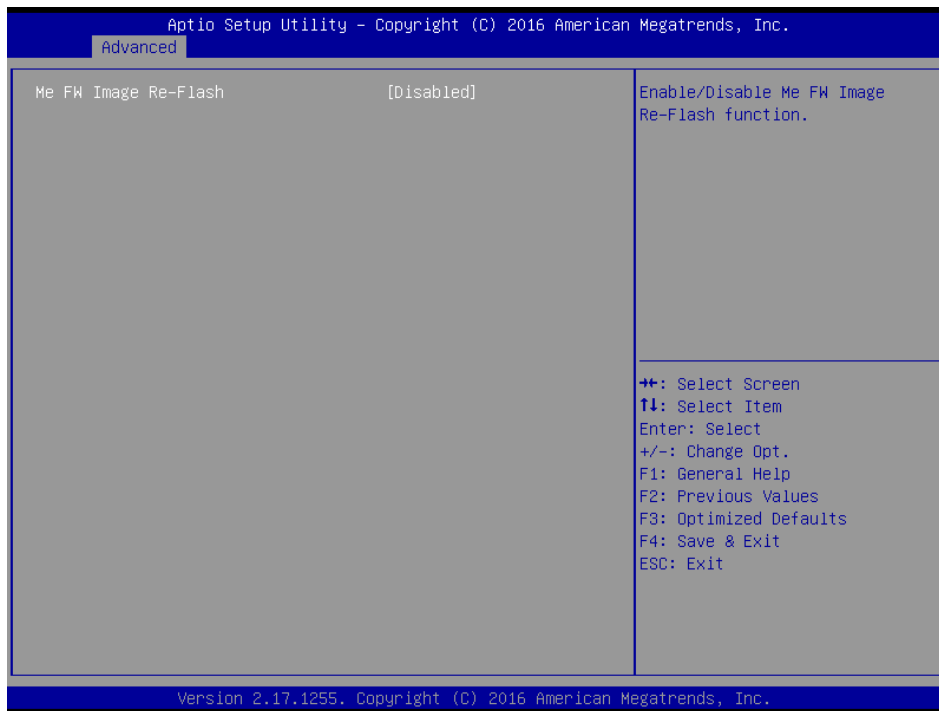

Item	Option	Description
ME FW Image Re-Flash	Disabled <b>[Default]</b> , Enabled	Enable/Disable Me FW Image Re-Flash function.

### 3.6.2.7 H/W Monitor

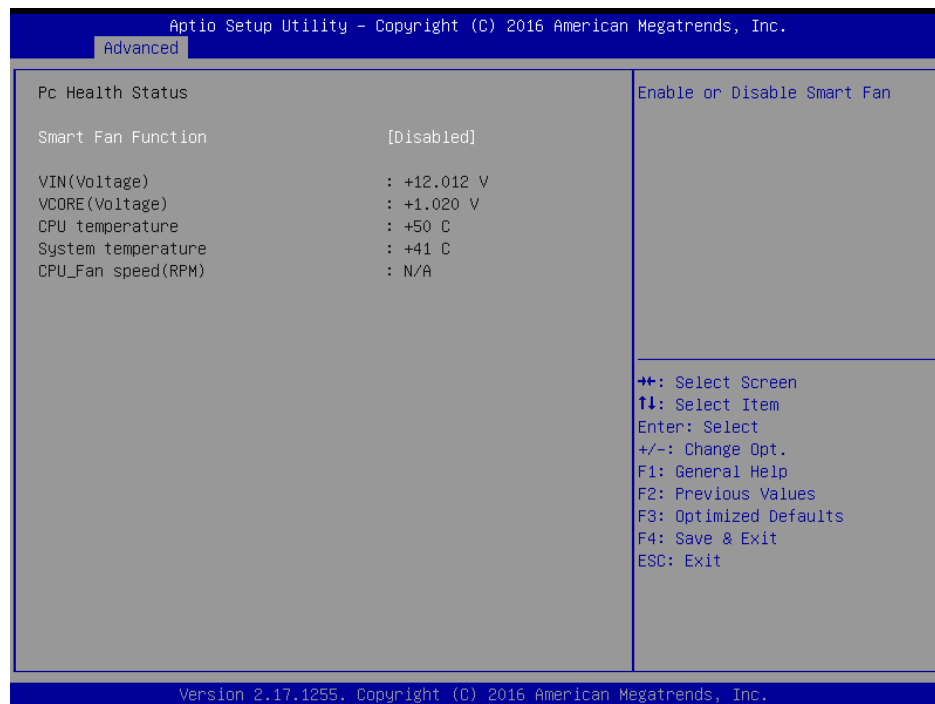

Item	Options	Description
Smart Fan Function	Enabled, Disabled[Default]	Enables or Disables Smart Fan.

### 3.6.2.7.1 Smart Fan Mode Configuration

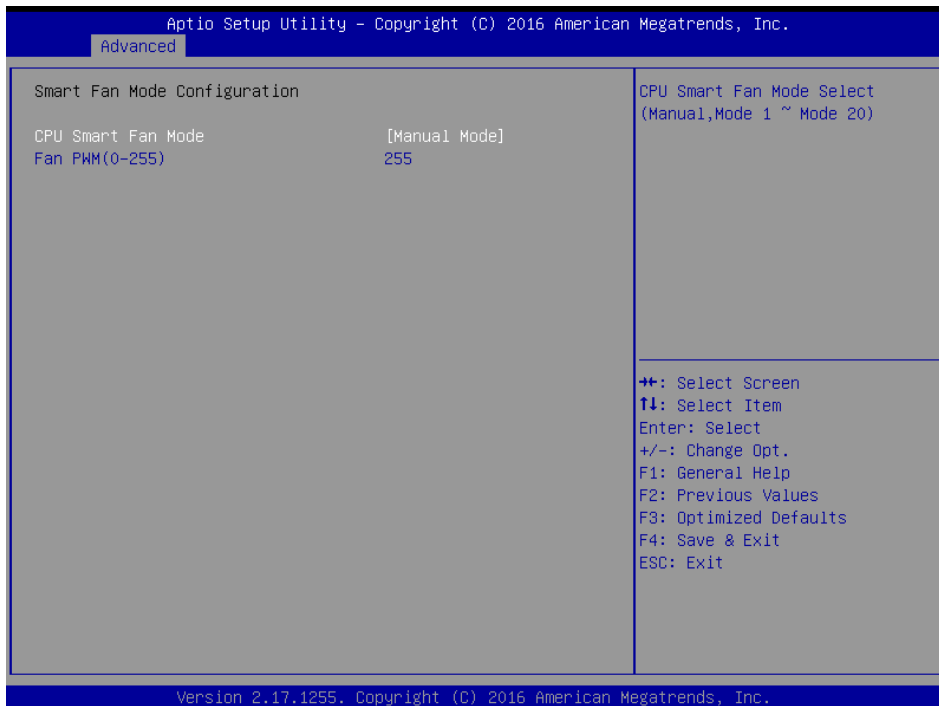

Item	Option	Description
CPU Smart Fan Mode	Manual Mode[Default], Mode 01/02/03/04/05 /06/07/08/09/10 /11/12/13/14/15 /16/17/18/19/20	CPU Smart Fan Mode Select (Manual, Mode 1~Mode 20).
Fan PWM (0-255)	0-255[Default]	Fan PWM duty (0-255).



3.6.2.8 S5 RTC Wake Settings

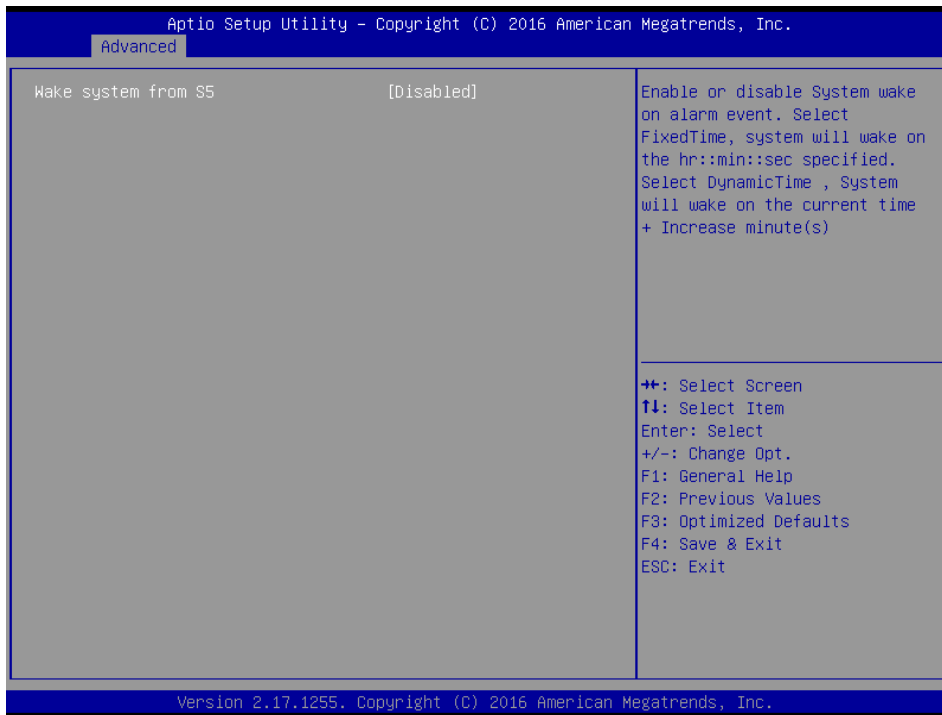

Item	Options	Description
Wake system from S5	Disabled[Default], Fixed Time Dynamic Time	Enable or disable System wake on alarm event. Select Fixed Time, system will wake on the hr::min::sec specified. Select Dynamic Time, System will wake on the current time + Increase minute(s).

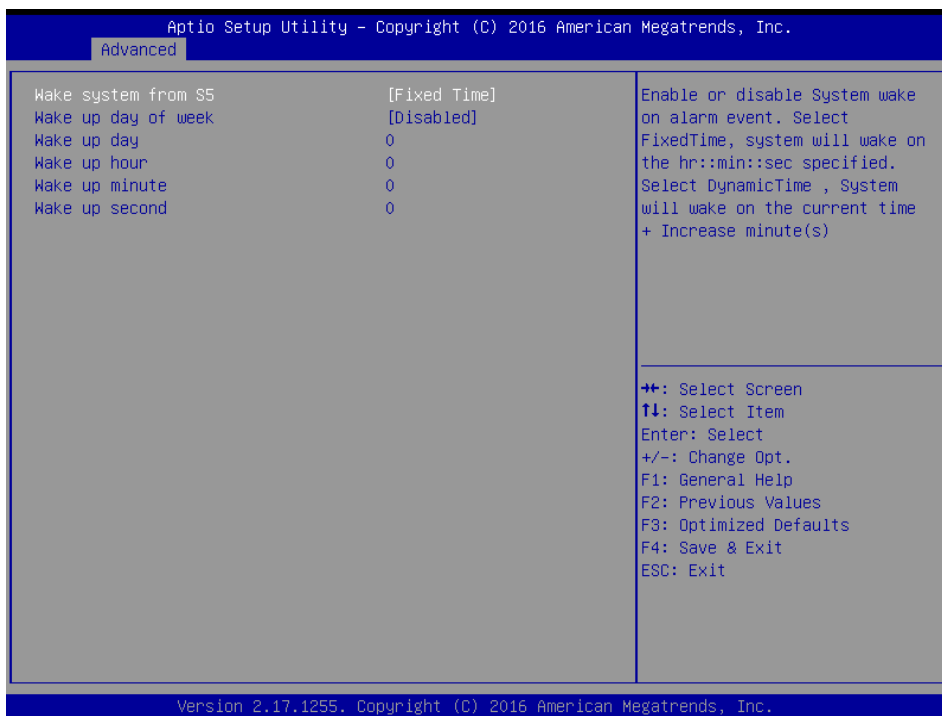

# ESM-SKLA User's Manual

Item	Options	Description
Wake system from S5	Disabled, Fixed Time[Default] Dynamic Time	Enable or disable System wake on alarm event. Select Fixed Time, system will wake on the hr::min::sec specified. Select Dynamic Time, System will wake on the current time + Increase minute(s).
Wake up day of week	Disabled[Default] Monday-Friday Monday-Saturday	Wake up day of week. (Monday-Friday) or (Monday-Saturday).
Wake up day	1-31	Select 0 for daily system wake up 1-31 for which day of the month that you would like the system to wake up.
Wake up hour	0-23	Select 0-23 For example enter 3 for 3am and 15 for 3pm.
Wake up minute	0-23	Select 0-23 For example enter 3 for 3am and 15 for 3pm.
Wake up second	0-23	Select 0-23 For example enter 3 for 3am and 15 for 3pm.

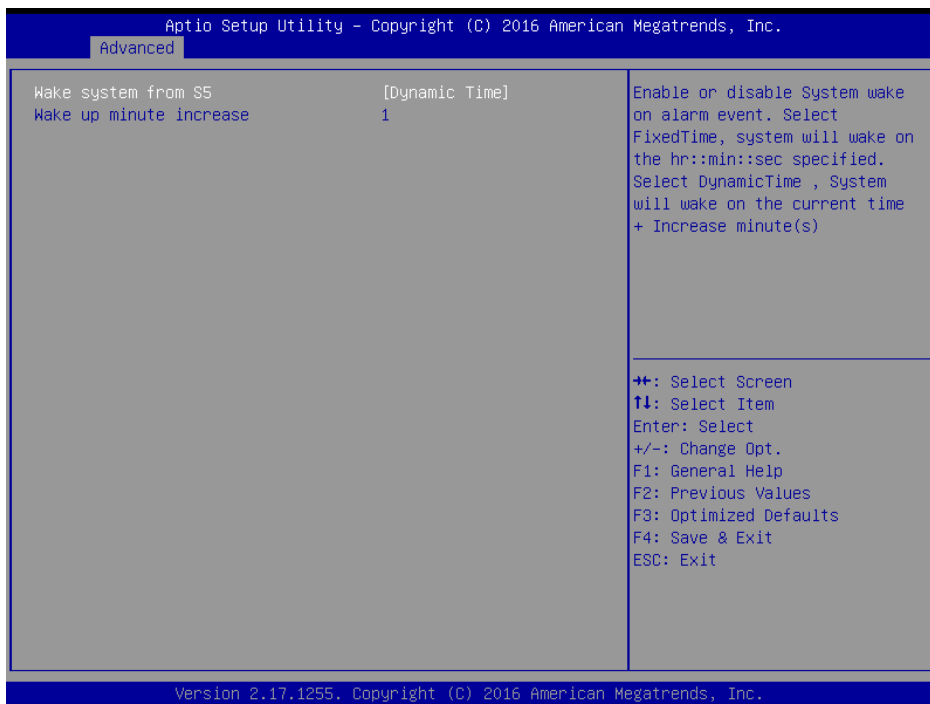

Item	Options	Description
Wake system from S5	Disabled, Fixed Time Dynamic Time[Default]	Enable or disable System wake on alarm event. Select Fixed Time, system will wake on the hr::min::sec specified. Select Dynamic Time, System will wake on the current time + Increase minute(s).
Wake up minute increase	1-5	1-5.

### 3.6.2.9 Serial Port Console Redirection



Item	Options	Description
Console Redirection	Disabled[Default], Enabled	Console Redirection Enable or Disable.

### 3.6.2.10 CPU Configuration

Use the CPU configuration menu to view detailed CPU specification and configure the CPU.

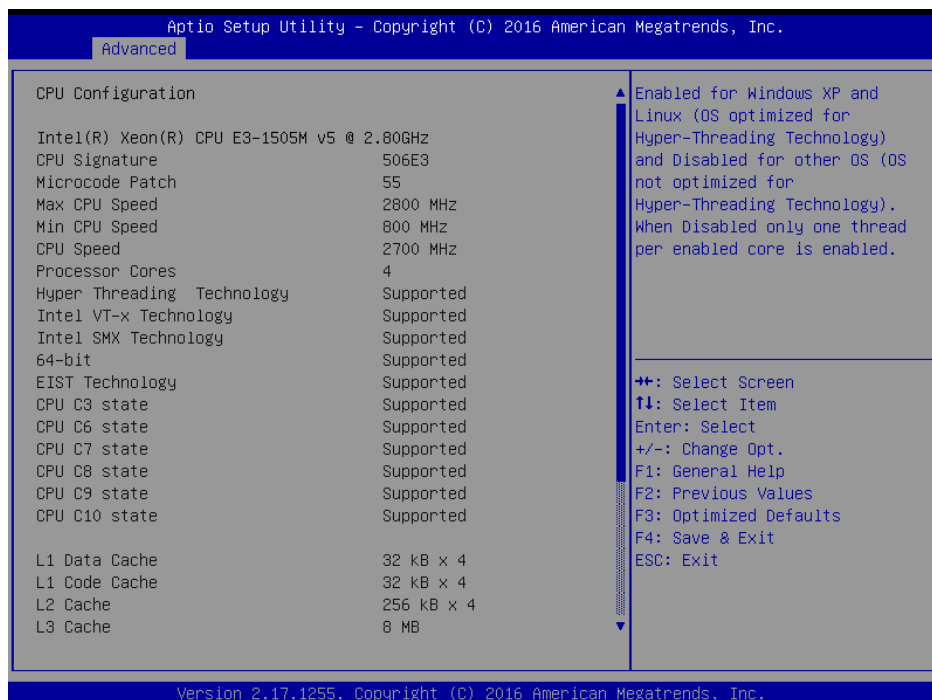

# ESM-SKLA User's Manual

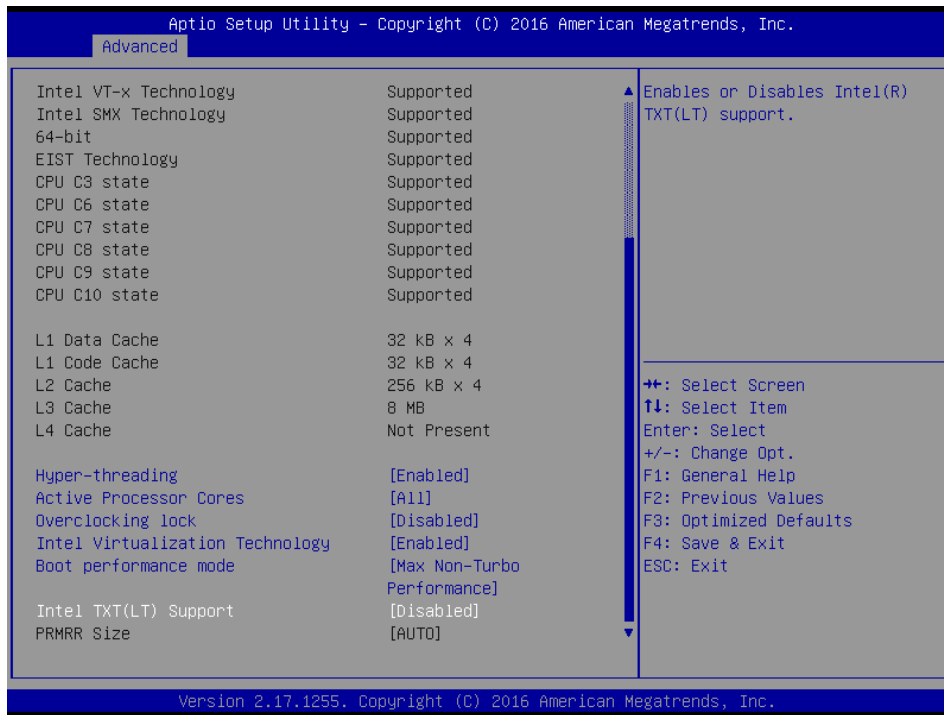

Item	Options	Description
<b>Hyper-threading</b>	Disabled, Enabled[ <b>Default</b> ]	Enabled for Windows XP and Linux (OS optimized for Hyper-Threading Technology) and Disabled for other OS (OS not optimized for Hyper-Threading Technology). When Disabled only one thread per enabled core is enabled.
<b>Active Processor Cores</b>	All[ <b>Default</b> ] 1 2 3	Number of cores to enable in each processor package.
<b>Overclocking lock</b>	Disabled[ <b>Default</b> ], Enabled	FLEX_RATIO (194) MSR.
<b>Intel Virtualization Technology</b>	Disabled Enabled[ <b>Default</b> ]	When enabled, a VMM can utilize the additional hardware capabilities provided by Vanderpool Technology.
<b>Boot performance mode</b>	Max Battery Max Non-Turbo Performance[ <b>Default</b> ] Turbo Performance	Select the performance state that the BIOS will set before OS handoff.
<b>Intel TXT(LT) Support</b>	Disabled[ <b>Default</b> ], Enabled	Enables or Disables Intel® TXT(LT) support.

### 3.6.2.11 Intel TXT Configuration



### 3.6.2.12 SATA Configuration



Item	Options	Description
SATA Controller(s)	Enabled[Default] Disabled,	Enable or disable SATA Device.

## ESM-SKLA User's Manual

<b>SATA Mode Selection</b>	AHCI[ <b>Default</b> ], RAID	Determines how SATA controller(s) operate.
<b>Aggressive LPM Support</b>	Enabled[ <b>Default</b> ] Disabled	Enable PCH to aggressively enter link power state.
<b>Port 0/1/2/3</b>	Enabled[ <b>Default</b> ] Disabled,	Enable or Disable SATA Port.
<b>SATA Device Type</b>	Hard Disk Drive[ <b>Default</b> ] Solid State Drive	Identify the SATA port is connected to Solid State Drive or Hard Disk Drive.
<b>Topology</b>	Unknown ISATA[ <b>Default</b> ] Direct Connect Flex M2	Identify the SATA Topology if it is Default or ISATA or Flex or DirectConnect or M2.

### 3.6.2.13 Network Stack Configuration

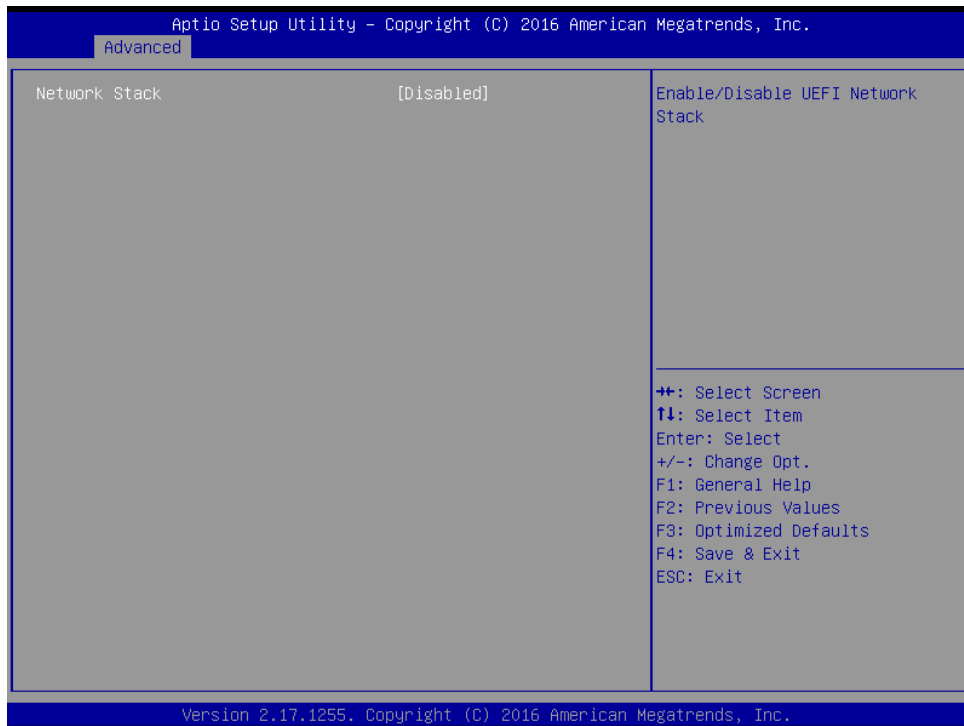

Item	Options	Description
<b>Network Stack</b>	Enabled Disabled[ <b>Default</b> ]	Enable/Disable UEFI Network Stack.

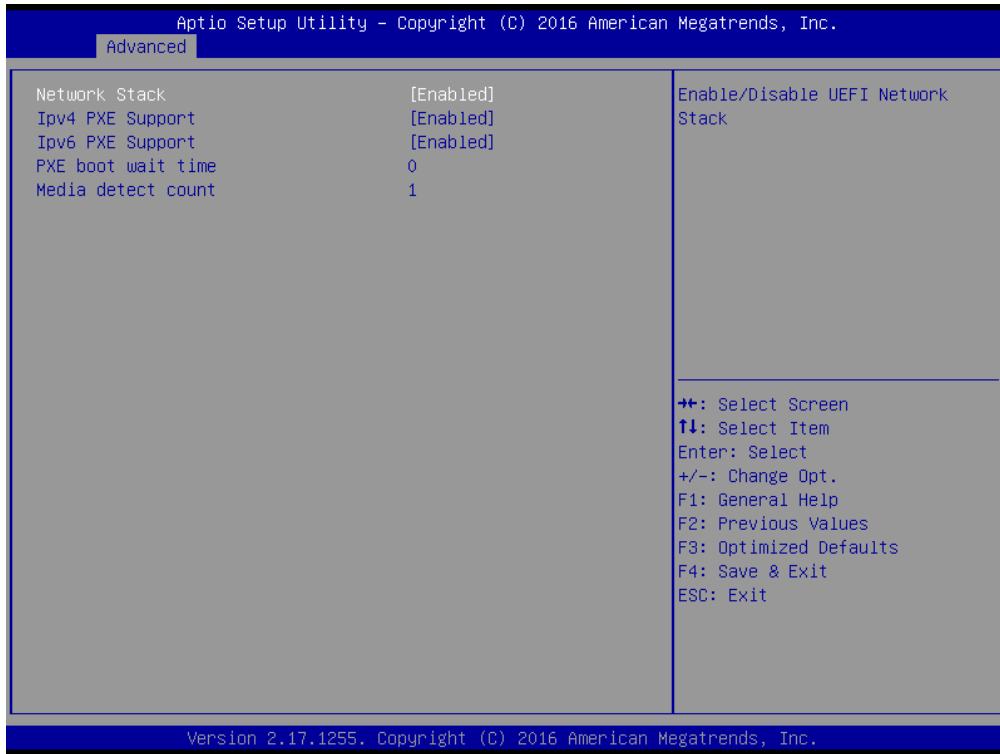

Item	Options	Description
<b>Network Stack</b>	Enabled[Default] Disabled	Enable/Disable UEFI Network Stack.
<b>Ipv4 PXE Support</b>	Enabled[Default] Disabled	Enable Ipv4 PXE Boot Support. If disabled IPV4 PXE boot option will not be created.
<b>Ipv6 PXE Support</b>	Enabled[Default] Disabled	Enable Ipv6 PXE Boot Support. If disabled IPV6 PXE boot option will not be created.
<b>PXE boot wait time</b>	0	Wait time to press ESC key to abort the PXE boot.
<b>Media detect count</b>	1	Number of times presence of media will be checked.

3.6.2.14 CSM Configuration



Item	Options	Description
CSM Support	Enabled Disabled[Default]	Enable/Disable CSM Support.

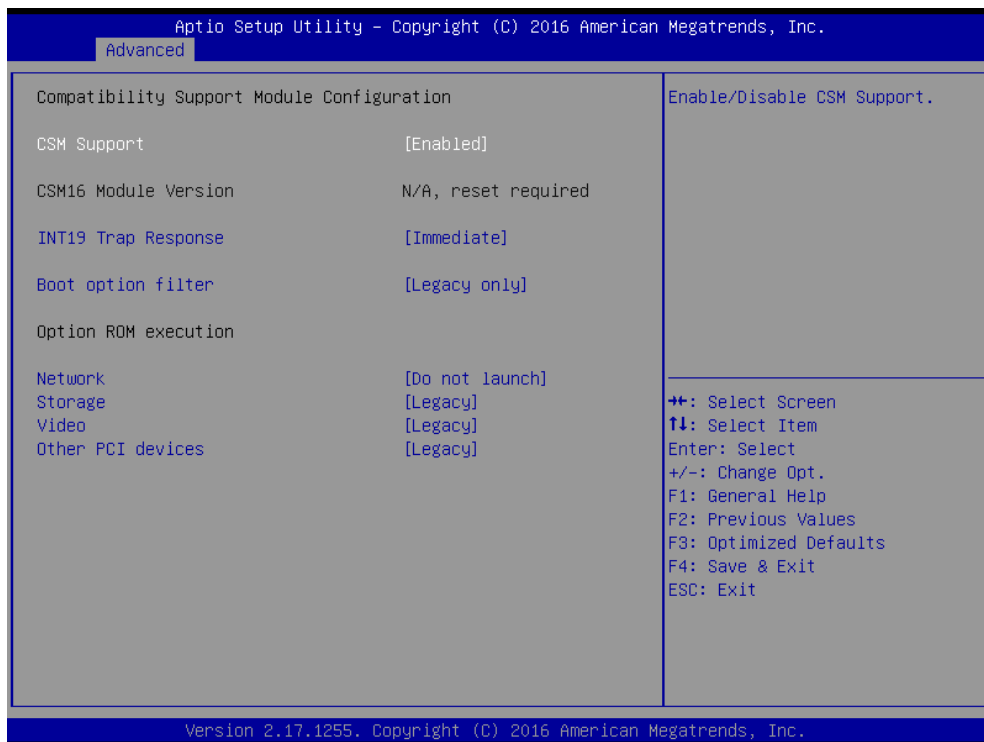



Item	Options	Description
<b>CSM Support</b>	Enabled[Default] Disabled	Enable/Disable CSM Support.
<b>INT19 Trap Response</b>	Immediate[Default] Postponed	BIOS reaction on INT19 trapping by Option ROM: IMMEDIATE – execute the trap right away; POSTPONED – execute the trap during legacy boot.
<b>Boot Option filter</b>	UEFI and Legacy Legacy only[Default] UEFI only	This option controls Legacy/UEFI ROMs priority.
<b>Network</b>	Do not launch[Default] UEFI Legacy	Controls the execution of UEFI and Legacy PXE OpROM.
<b>Storage</b>	Do not launch UEFI Legacy[Default]	Controls the execution of UEFI and Legacy Storage OpROM.
<b>Video</b>	Do not launch UEFI Legacy[Default]	Controls the execution of UEFI and Legacy Video OpROM.
<b>Other PCI devices</b>	Do not launch UEFI Legacy[Default]	Determines OpROM execution policy for devices other than Network, Storage, or Vide.

### 3.6.2.15 USB Configuration

The USB Configuration menu helps read USB information and configures USB settings.



Item	Options	Description
<b>XHCI Hand-off</b>	Enabled[Default] Disabled	This is a workaround for OSEw without XHCI hand-off support. The XHCI ownership change

## ESM-SKLA User's Manual

		should be claimed by XHCI driver.
<b>Port 60/64 Emulation</b>	Enabled Disabled[ <b>Default</b> ]	Enable I/O port 60h/64h emulation support. This should be enabled for the complete USB keyboard legacy support for non-USB aware OSes.
<b>USB transfer time-out</b>	1 sec 5 sec 10 sec 20 sec[ <b>Default</b> ]	The time-out value for Control, Bulk, and Interrupt transfers.
<b>Device reset time-out</b>	10 sec 20 sec[ <b>Default</b> ] 30 sec 40 sec	USB mass storage device Start Unit command time-out.
<b>Device power-up delay</b>	Auto[ <b>Default</b> ] Manual	Maximum time the device will take before it properly reports itself to the Host Controller. 'Auto' uses default value: for a Root port it is 100ms, for a Hub port the delay is taken form Hub descriptor.
<b>Mass Storage Devices</b>	Auto[ <b>Default</b> ] Floppy Forced FDD Hard Disk CD-ROM	Mass storage device emulation type. 'AUTO' enumerates devices according to their media format. Optical drives are emulated as 'CDROM', drives with no media will be emulated according to a drive type.

### 3.6.3 Chipset



### 3.6.3.1 System Agent (SA) Configuration

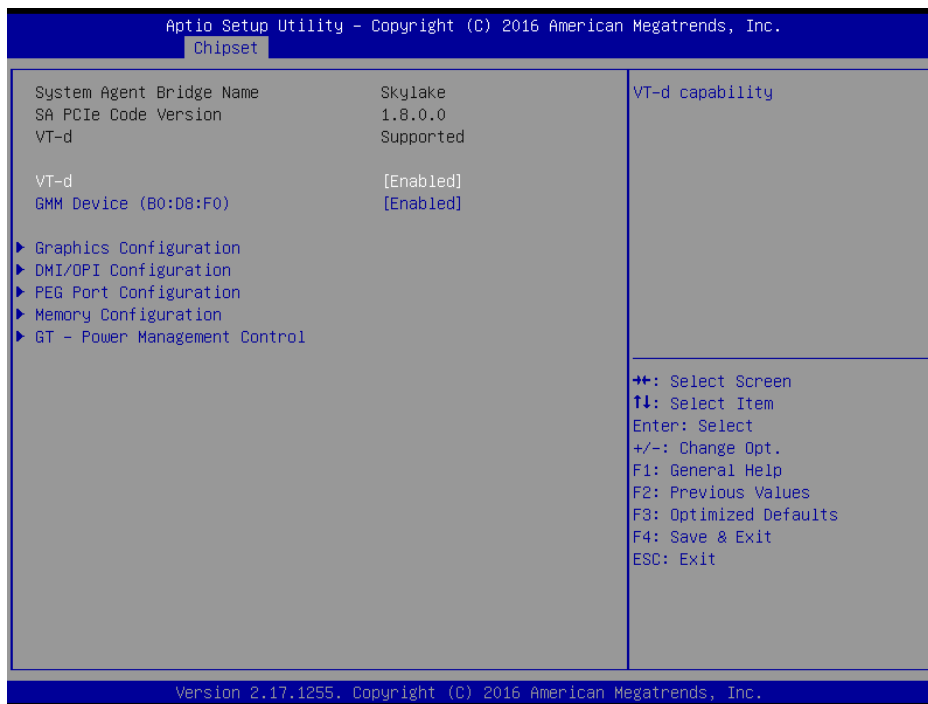

Item	Option	Description
<b>VT-d</b>	Enabled[Default] Disabled	VT-d capability.
<b>GMM Device (B0:D8:F0)</b>	Enabled[Default] Disabled	Enable/Disable SA GMM Device.

#### 3.6.3.1.1 Graphics Configuration

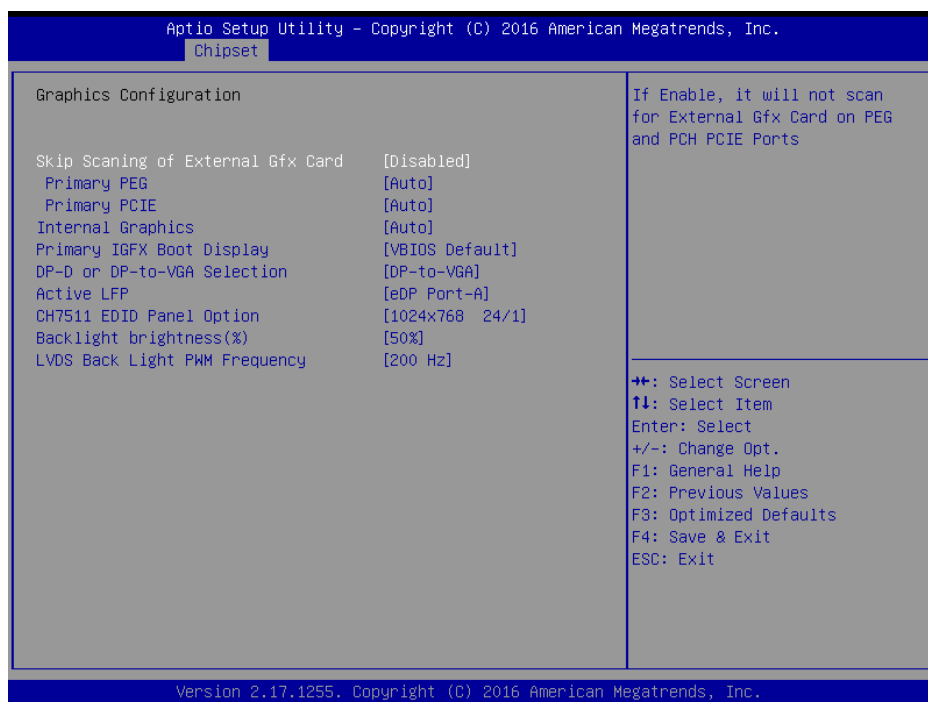

## ESM-SKLA User's Manual

Item	Option	Description
<b>Skip Scanning of External Gfx Card</b>	Disabled[Default] Enabled	If Enable, it will not scan for External Gfx Card on PEG and PCH PCIE Ports.
<b>Primary PEG</b>	Auto[Default] PEG11 PEG12	Select PEG0/PEG1/PEG2/PEG3 Graphics device should be Primary PEG.
<b>Primary PCIE</b>	Auto[Default] PCIE5 PCIE6 PCIE7 PCIE8	Select Auto/PCIE1/PCIE2/PCIE3/PCIE4/PCIE5 /PCIE6/PCIE7 of D28:F0/F1/F2/F3/F4/F5/F6/F7, PCIE8/PCIE9/PCIE10/PCIE11/PCIE12/PCIE13/PCIE14/PCIE15 of D29:F0/F1/F2/F3/F4/F5/F6/F7, PCIE16/PCIE17/PCIE18/PCIE19 of D27:F0/F1/F2 /F3, Graphics device should be Primary PCIE.
<b>Internal Graphics</b>	Auto[Default] Disabled Enabled	Keep IGFX enabled based on the setup options.
<b>Primary IGFX Boot Display</b>	VBIOS Default[Default] DP-D or DP-to-VGA eDP-to-LVDS HDMI1 ADD2	Select the Video Device which will be activated during POST. This has no effect if external graphics resent. Secondary boot display selection will appear based on your selection. VGA modes will be supported only on primary display.
<b>DP-D or DP-to-VGA Selection</b>	DP-D DP-to-VGA[Default]	Selection of DP Port-D output.
<b>Active LFP</b>	No LVDS eDP Port-A[Default]	Configuring LFP usage.
<b>CH7511 EDID Panel Option</b>	1024x768 24/1[Default] 800x600 18/1 1024x768 18/1 1366x768 18/1 1024x600 18/1 1280x800 18/1 1920x1200 24/2 1920x1080 18/2 1280x1024 24/2 1440x900 18/2 1600x1200 24/2 1366x768 24/1 1920x1080 24/2 1680x1050 24/2	Port1-EDP to LVDS (Chrotel 7511) Panel EDID Option.
<b>Backlight brightness (%)</b>	00% 25% 50%[Default] 75% 100%	Select LVDS back light PWM duty.
<b>LVDS Back Light PWM Frequency</b>	200 Hz[Default] 300 Hz 400 Hz	Select LVDS back light PWM Frequency.

	500 Hz 700 Hz 1kHz 2kHz 3kHz 5kHz 10kHz 20kHz	
--	--	--

### 3.6.3.1.2 DMI/OPI Configuration

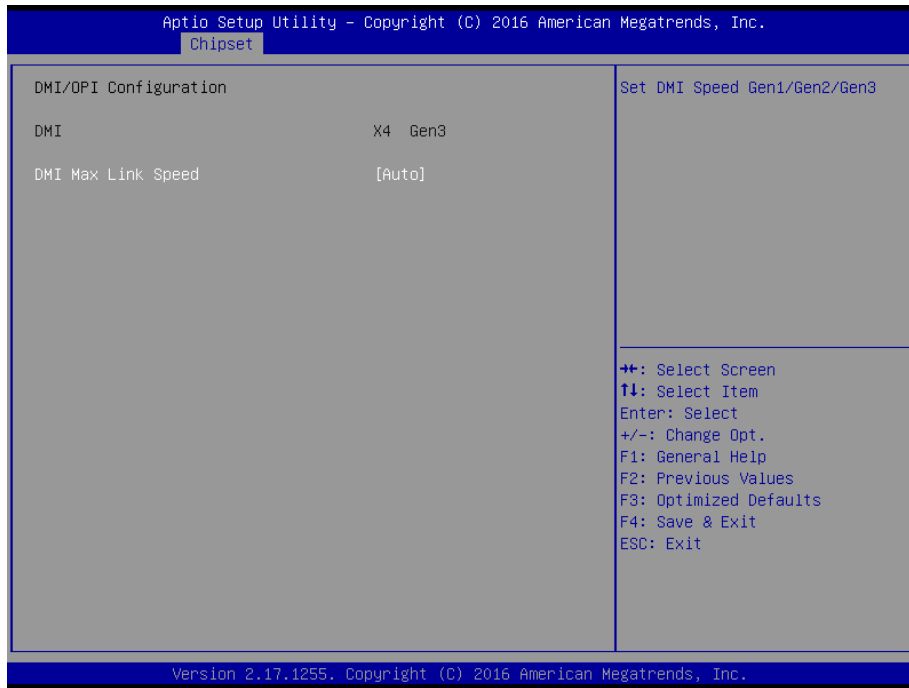

Item	Option	Description
<b>DMI Max Link Speed</b>	Auto[Default]	Set DMI Speed Gen1/Gen2/Gen3.
	Gen1	
	Gen2	
	Gen3	

3.6.3.1.3 PEG Port Configuration

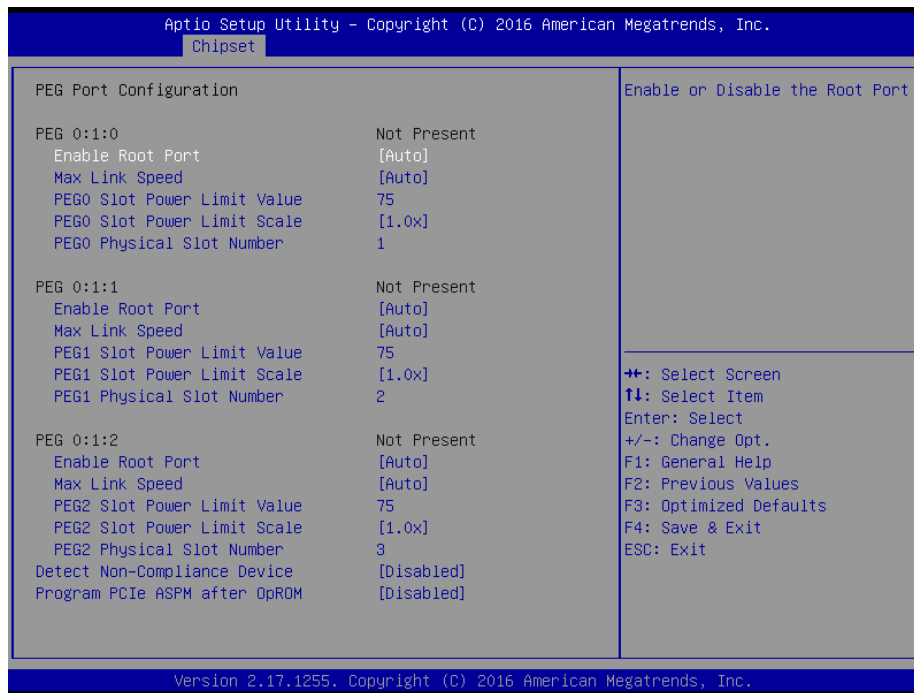

PEG 0:1:0

Item	Option	Description
Enable Root Port	Disabled Enabled Auto[Default]	Enable or Disable the Root Port.
Max Link Speed	Auto[Default] Gen1 Gen2 Gen3	Configure PEG 0:1:0 Max Speed.
PEG0 Slot Power Limit Value	0-255 75[Default]	Sets the upper limit on power supplied by slot, Power limit (in Watts) is calculated by multiplying this value by the Slot Power Limit Scale. Values 0-255.
PEG0 Slot Power Limit Scale	1.0x[Default] 0.1x 0.01x 0.001x	Select the scale used for the Slot Power Limit Value.
PEG0 Physical Slot Number	0-8191 1[Default]	Set the physical slot number attached to this Port. The number has to be globally unique within the chassis. Values 0-8191.

PEG 0:1:1

Item	Option	Description
Enable Root Port	Disabled Enabled Auto[Default]	Enable or Disable the Root Port.

<b>Max Link Speed</b>	Auto[Default] Gen1 Gen2 Gen3	Configure PEG 0:1:1 Max Speed.
<b>PEG1 Slot Power Limit Value</b>	0-255 75[Default]	Sets the upper limit on power supplied by slot, Power limit (in Watts) is calculated by multiplying this value by the Slot Power Limit Scale. Values 0-255.
<b>PEG1 Slot Power Limit Scale</b>	1.0x[Default] 0.1x 0.01x 0.001x	Select the scale used for the Slot Power Limit Value.
<b>PEG1 Physical Slot Number</b>	0-8191 2[Default]	Set the physical slot number attached to this Port. The number has to be globally unique within the chassis. Values 0-8191.

**PEG 0:1:2**

Item	Option	Description
<b>Enable Root Port</b>	Disabled Enabled Auto[Default]	Enable or Disable the Root Port.
<b>Max Link Speed</b>	Auto[Default] Gen1 Gen2 Gen3	Configure PEG 0:1:2 Max Speed.
<b>PEG2 Slot Power Limit Value</b>	0-255 75[Default]	Sets the upper limit on power supplied by slot, Power limit (in Watts) is calculated by multiplying this value by the Slot Power Limit Scale. Values 0-255.
<b>PEG2 Slot Power Limit Scale</b>	1.0x[Default] 0.1x 0.01x 0.001x	Select the scale used for the Slot Power Limit Value.
<b>PEG2 Physical Slot Number</b>	0-8191 3[Default]	Set the physical slot number attached to this Port. The number has to be globally unique within the chassis. Values 0-8191.
<b>Detect Non-Compliance Device</b>	Disabled[Default] Enabled	Detect Non-Compliance PCI Express Device in PEG.
<b>Program PCIe ASPM after OpROM</b>	Disabled[Default] Enabled	Enabled: PCIe ASPM will be programmed after OpROM. Disabled: PCIe ASPM will be programmed before OpROM.

3.6.3.1.4 Memory Configuration

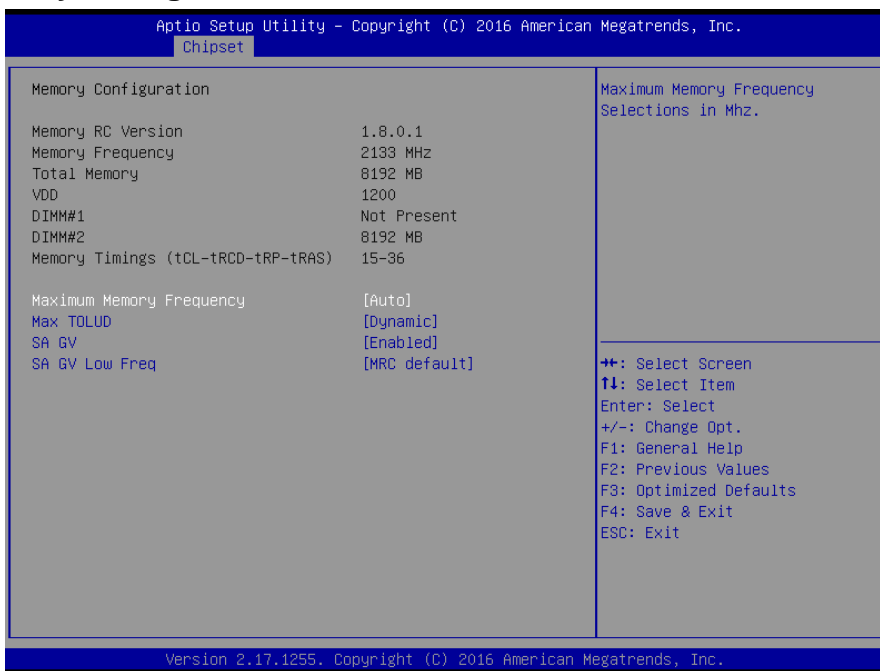

Item	Option	Description
<b>Maximum Memory Frequency</b>	Auto[Default] /1067/1200/1333/1400/1600 /1800/1867/2000/2133/2200 /2400/2600/2667/2800/2933 /3000/3200	Maximum Memory Frequency Selections in Mhz.
<b>Max TOLUD</b>	Dynamic[Default] /1GB/1.25GB/1.5GB/1.75GB /2GB/2.25GB/2.5GB/2.75GB /3GB/3.25GB/3.5GB	Maximum Value of TOLUD. Dynamic assignment would adjust TOLUD automatically based on largest MMIO length of installed graphic controller.
<b>SA GV</b>	Disabled Fixed Low Fixed High Enabled[Default]	System Agent Geyserville. Fixed Low/High: SA GV disabled, MR only runs tasks from Low or High point.
<b>SA GV Low Freq</b>	MRC default[Default] /1067/1200/1333/1400/1600 /1800/1867	System Agent Geyserville. Set frequency for low point. Default 1067 for LPDDR3/DDR3, 1333 for DDR4.

**Note:**

Vary depending on the CPU / RAM module.



### 3.6.3.1.5 GT- Power Management Control

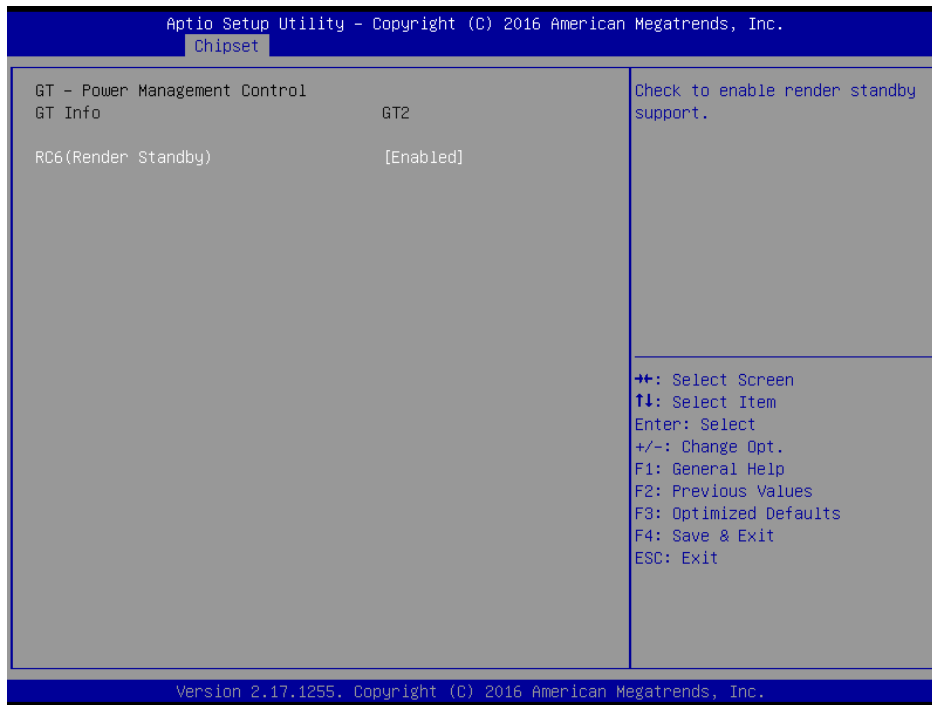

Item	Option	Description
RC6 (Render Standby)	Enabled[Default] Disabled	Check to enable render standby support.

### 3.6.3.2 PCH-IO Configuration

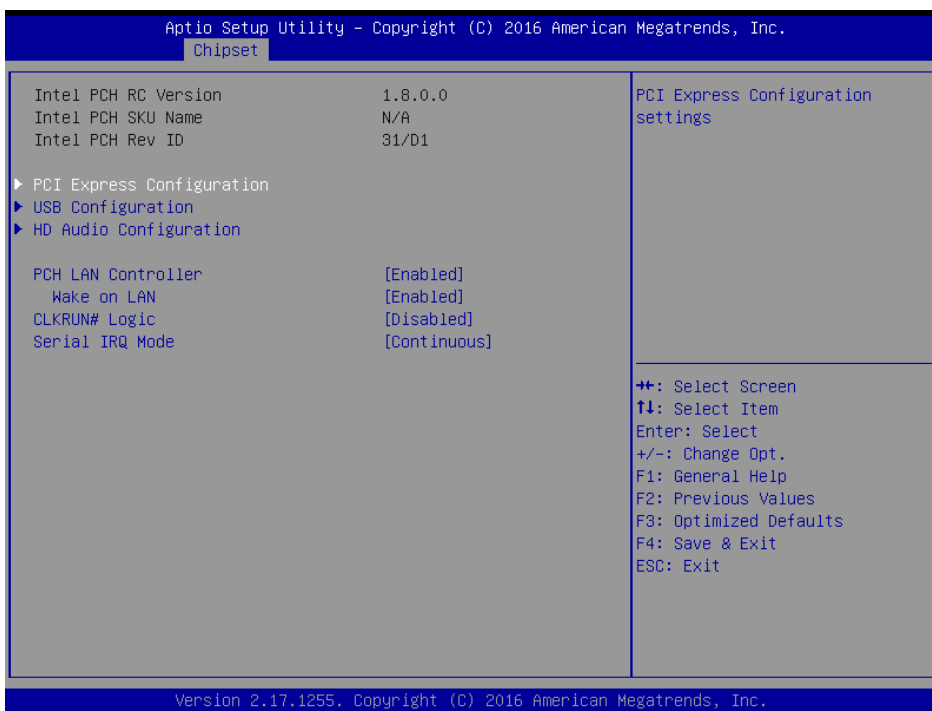

## ESM-SKLA User's Manual

Item	Option	Description
<b>PCH LAN Controller</b>	Disabled Enabled[Default]	Enable or disable onboard NIC.
<b>Wake on LAN</b>	Disabled Enabled[Default]	Enable or disable integrated LAN to wake the system. (The Wake On LAN cannot be disabled if ME is on at Sx state.)
<b>CLKRUN# Logic</b>	Disabled[Default] Enabled	Enable the CLKRUN# logic to stop the PCI clocks.
<b>Serial IRQ Mode</b>	Quiet Continuous[Default]	Configure Serial IRQ Mode.

### 3.6.3.2.1 PCI Express Configuration

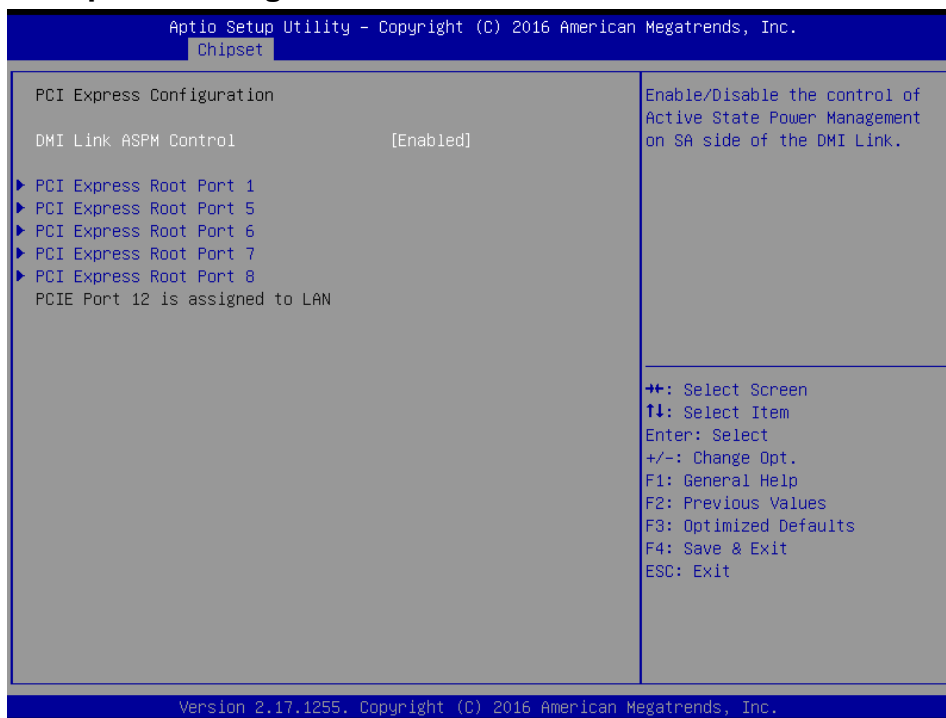

Item	Option	Description
<b>DMI Link ASPM Control</b>	Disabled Enabled[Default]	Enable/Disable the control of Active State Power Management on SA side of the DMI Link.

### 3.6.3.2.1.1 PCI Express Root Port 1

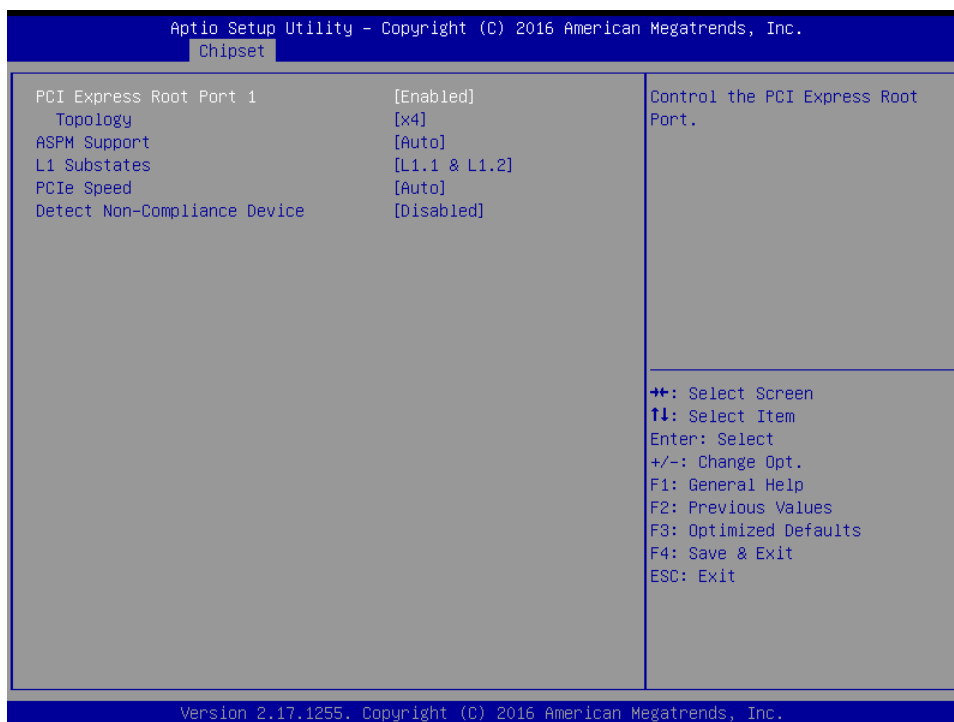

Item	Option	Description
<b>PCI Express Root Port 1</b>	Enabled[Default], Disabled	Control the PCI Express Root Port.
<b>Topology</b>	Unknown x1, x4[Default] Sata Express M2	Identify the SATA Topology if it is Default or ISATA or Flex or DirectConnect or M2.
<b>ASPM Support</b>	Disabled L0s L1 L0sL1 Auto[Default],	Set the ASPM Level: Force L0s – Force all links to L0s State AUTO – BIOS auto configure DISABLE – Disables ASPM.
<b>L1 Substates</b>	Disabled L1.1 L1.2 L1.1 & L1.2[Default],	PCI Express L1 Substates settings.
<b>PCIe Speed</b>	Auto[Default] Gen1 Gen2 Gen3	Select PCI Express port speed.
<b>Detect Non-Compliance Device</b>	Disabled[Default], Enabled	Detect Non-Compliance PCI Express Device. If enable, it will take more time at POST time.

3.6.3.2.1.2 PCI Express Root Port 5

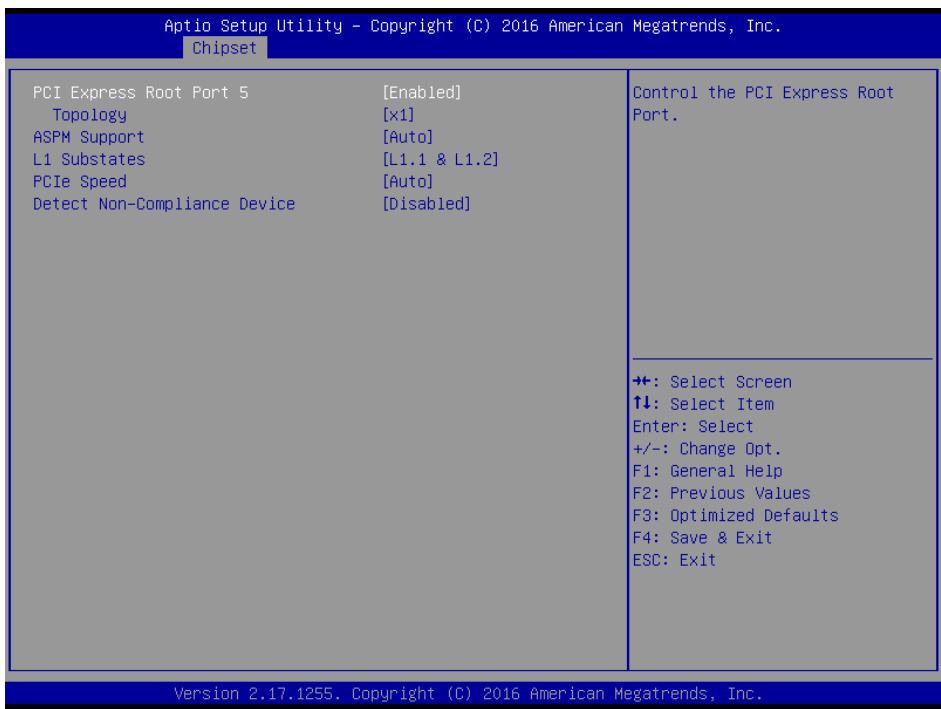

Item	Option	Description
<b>PCI Express Root Port 5</b>	Enabled <b>[Default]</b> , Disabled	Control the PCI Express Root Port.
<b>Topology</b>	Unknown x1 <b>[Default]</b> x4 Sata Express M2	Identify the SATA Topology if it is Default or ISATA or Flex or DirectConnect or M2.
<b>ASPM Support</b>	Disabled L0s L1 L0sL1 Auto <b>[Default]</b> ,	Set the ASPM Level: Force L0s – Force all links to L0s State AUTO – BIOS auto configure DISABLE – Disables ASPM.
<b>L1 Substates</b>	Disabled L1.1 L1.2 L1.1 & L1.2 <b>[Default]</b> ,	PCI Express L1 Substates settings.
<b>PCIe Speed</b>	Auto <b>[Default]</b> Gen1 Gen2 Gen3	Select PCI Express port speed.
<b>Detect Non-Compliance Device</b>	Disabled <b>[Default]</b> , Enabled	Detect Non-Compliance PCI Express Device. If enable, it will take more time at POST time.

### 3.6.3.2.1.3 PCI Express Root Port 6

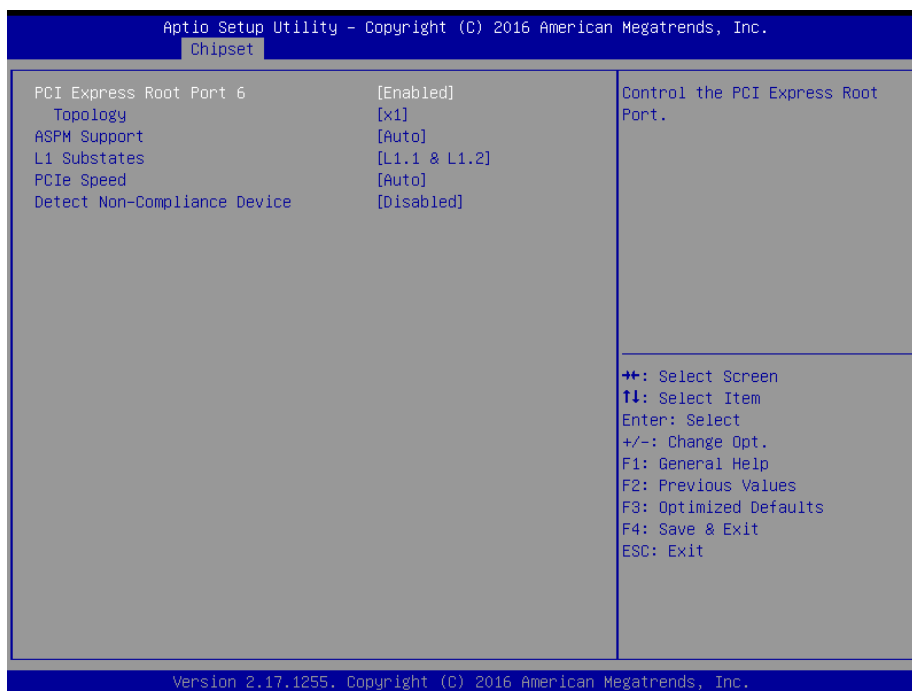

Item	Option	Description
<b>PCI Express Root Port 6</b>	Enabled[Default], Disabled	Control the PCI Express Root Port.
<b>Topology</b>	Unknown x1[Default] x4 Sata Express M2	Identify the SATA Topology if it is Default or ISATA or Flex or DirectConnect or M2.
<b>ASPM Support</b>	Disabled L0s L1 L0sL1 Auto[Default],	Set the ASPM Level: Force L0s – Force all links to L0s State AUTO – BIOS auto configure DISABLE – Disables ASPM.
<b>L1 Substates</b>	Disabled L1.1 L1.2 L1.1 & L1.2[Default],	PCI Express L1 Substates settings.
<b>PCIe Speed</b>	Auto[Default] Gen1 Gen2 Gen3	Select PCI Express port speed.
<b>Detect Non-Compliance Device</b>	Disabled[Default], Enabled	Detect Non-Compliance PCI Express Device. If enable, it will take more time at POST time.

3.6.3.2.1.4 PCI Express Root Port 7

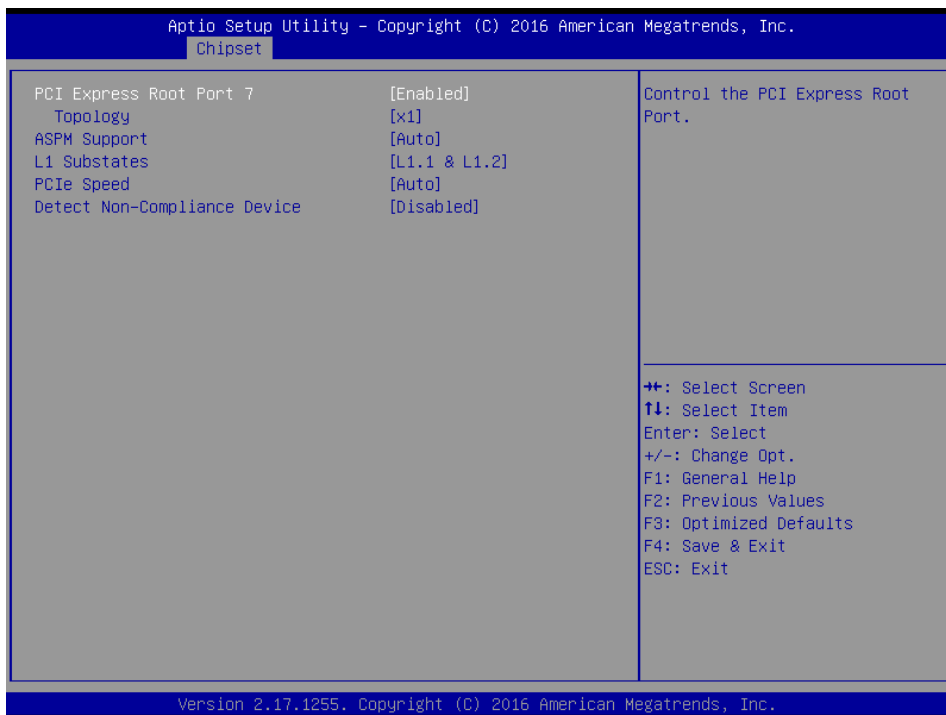

Item	Option	Description
<b>PCI Express Root Port 7</b>	Enabled[Default], Disabled	Control the PCI Express Root Port.
<b>Topology</b>	Unknown x1[Default] x4 Sata Express M2	Identify the SATA Topology if it is Default or ISATA or Flex or DirectConnect or M2.
<b>ASPM Support</b>	Disabled L0s L1 L0sL1 Auto[Default],	Set the ASPM Level: Force L0s – Force all links to L0s State AUTO – BIOS auto configure DISABLE – Disables ASPM.
<b>L1 Substates</b>	Disabled L1.1 L1.2 L1.1 & L1.2[Default],	PCI Express L1 Substates settings.
<b>PCIe Speed</b>	Auto[Default] Gen1 Gen2 Gen3	Select PCI Express port speed.
<b>Detect Non-Compliance Device</b>	Disabled[Default], Enabled	Detect Non-Compliance PCI Express Device. If enable, it will take more time at POST time.

### 3.6.3.2.1.5 PCI Express Root Port 8

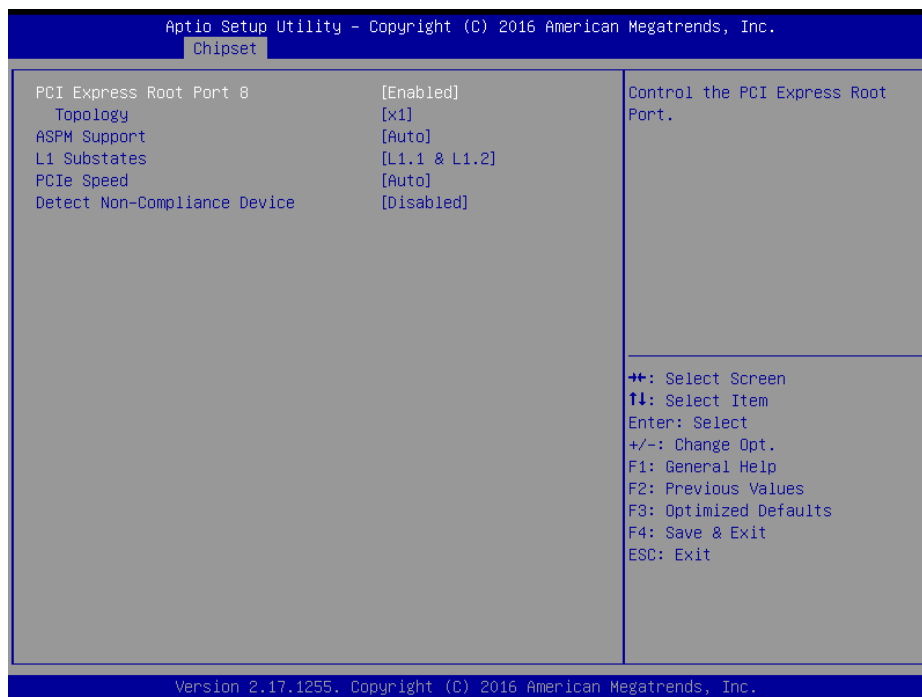

Item	Option	Description
<b>PCI Express Root Port 8</b>	Enabled[Default], Disabled	Control the PCI Express Root Port.
<b>Topology</b>	Unknown x1[Default] x4 Sata Express M2	Identify the SATA Topology if it is Default or ISATA or Flex or DirectConnect or M2.
<b>ASPM Support</b>	Disabled L0s L1 L0sL1 Auto[Default],	Set the ASPM Level: Force L0s – Force all links to L0s State AUTO – BIOS auto configure DISABLE – Disables ASPM.
<b>L1 Substates</b>	Disabled L1.1 L1.2 L1.1 & L1.2[Default],	PCI Express L1 Substates settings.
<b>PCIe Speed</b>	Auto[Default] Gen1 Gen2 Gen3	Select PCI Express port speed.
<b>Detect Non-Compliance Device</b>	Disabled[Default], Enabled	Detect Non-Compliance PCI Express Device. If enable, it will take more time at POST time.

3.6.3.2.2 USB Configuration

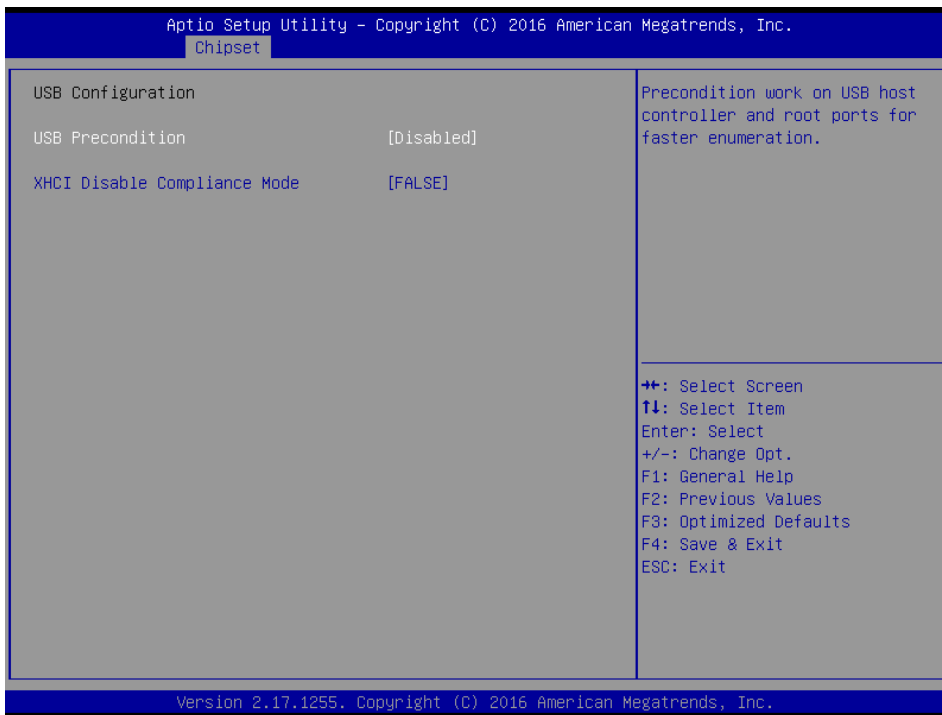

Item	Option	Description
USB Precondition	Enabled Disabled[Default],	Precondition work on USB host controller and root ports for faster enumeration.
XHCI Disable Compliance Mode	FALSE[Default], TRUE	Option to disable Compliance Mode. Default is FALSE to not disable Compliance Mode. Set TRUE to disable Compliance Mode.

3.6.3.2.3 HD Audio Configuration

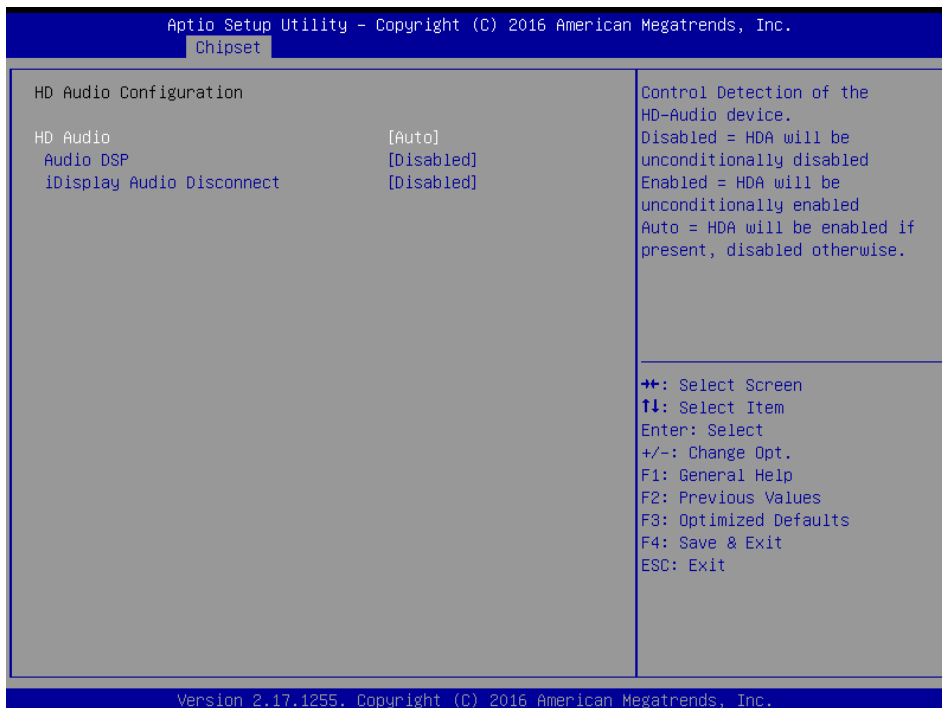



Item	Option	Description
HD Audio	Disabled Enabled Auto[Default],	Control Detection of the HD-Audio device. Disable = HDA will be unconditionally disabled Enabled = HDA will be unconditionally enabled Auto = HDA will be enabled if present, disabled otherwise.
Audio DSP	Disabled[Default] Enabled	Enable/Disable Audio DSP.
iDisplay Audio Disconnect	Disabled[Default] Enabled	Disconnects SDI2 signal to hide/disable iDisplay Audio Codec.

### 3.6.4 Security



- **Administrator Password**

Set setup Administrator Password

- **User Password**

Set User Password

3.6.4.1 Secure Boot menu

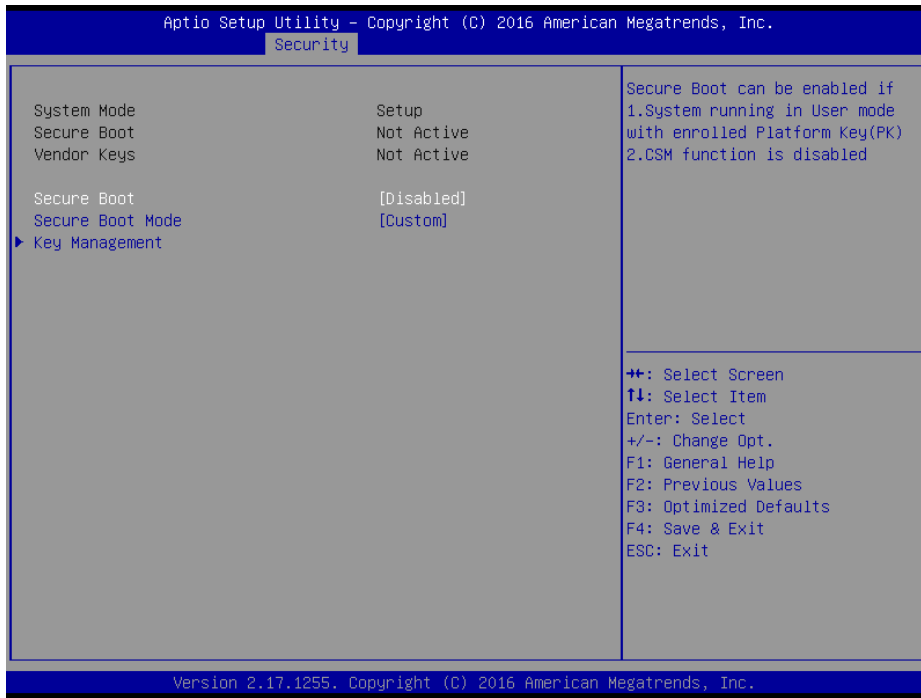

Item	Option	Description
<b>Secure Boot</b>	Disabled[Default] Enabled	Secure Boot can be enabled if 1.System running in User mode with enrolled Platform Key(PK) 2.CSM function is disabled.
<b>Secure Boot Mode</b>	Standard Custom[Default]	Secure Boot mode selector. 'Custom' Mode enables users to change Image Execution policy and manage Secure Boot Keys.

### 3.6.4.1.1 Key Management

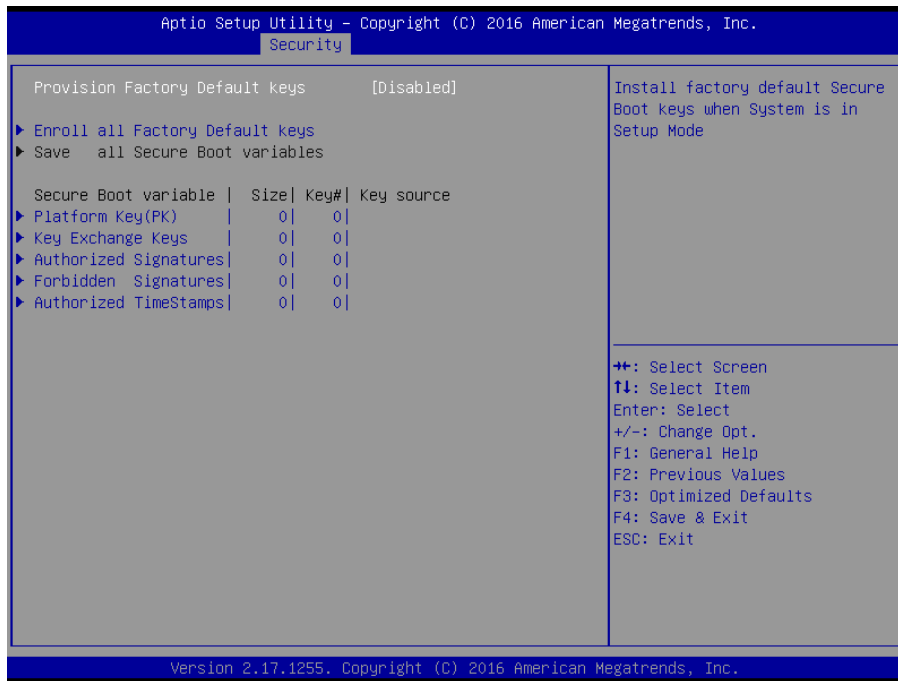

Item	Option	Description
Provision Factory Default Keys	Disabled[Default] Enabled	Install factory default Secure Boot keys when System is in Setup Mode.

### 3.6.5 Boot

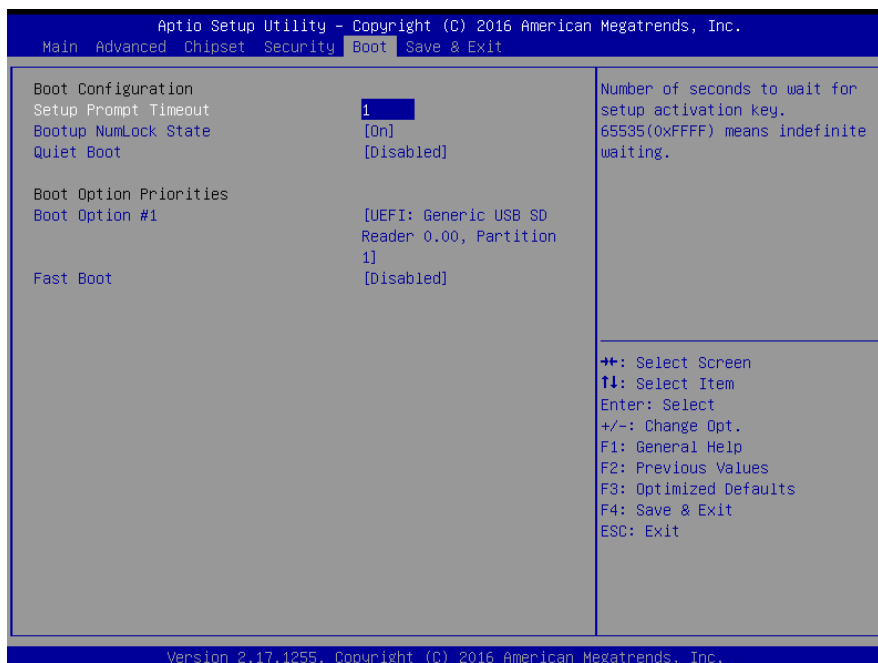

## ESM-SKLA User’s Manual

Item	Option	Description
Setup Prompt Timeout	1~ 65535	Number of seconds to wait for setup activation key. 65535(0xFFFF) means indefinite waiting.
Bootup NumLock State	On[Default] Off	Select the Keyboard NumLock state
Quiet Boot	Disabled[Default] Enabled	Enables or disables Quiet Boot option
Fast Boot	Disabled[Default] Enabled	Enables or disables boot with initialization of a minimal set of devices required to launch active boot option. Has no effect for BBS boot options.
Boot Option #1/2	Set the system boot order.	

### 3.6.6 Save and exit



#### 3.6.6.1 Save Changes and Reset

Reset the system after saving the changes.

#### 3.6.6.2 Discard Changes and Reset

Any changes made to BIOS settings during this session of the BIOS setup program are discarded. The setup program then exits and reboots the controller.

#### 3.6.6.3 Restore Defaults

This option restores all BIOS settings to the factory default. This option is useful if the

controller exhibits unpredictable behavior due to an incorrect or inappropriate BIOS setting.

**3.6.6.4 *Launch EFI Shell from filesystem device***

Attempts to Launch EFI Shell application (Shellx64.efi) from one of the available filesystem devices.

# 4. Drivers Installation

---



**Note:** Installation procedures and screen shots in this section are for your reference and may not be exactly the same as shown on your screen.

## 4.1 Install Chipset Driver

Insert the Supporting DVD-ROM to DVD-ROM drive, and it should show the index page of Avalue's products automatically. If not, locate Index.htm and choose the product from the menu left, or link to `\\Driver_Chipset\Intel\ESM-SKLA`.



**Note:** The installation procedures and screen shots in this section are based on Windows 8 operation system. If the warning message appears while the installation process, click Continue to go on.

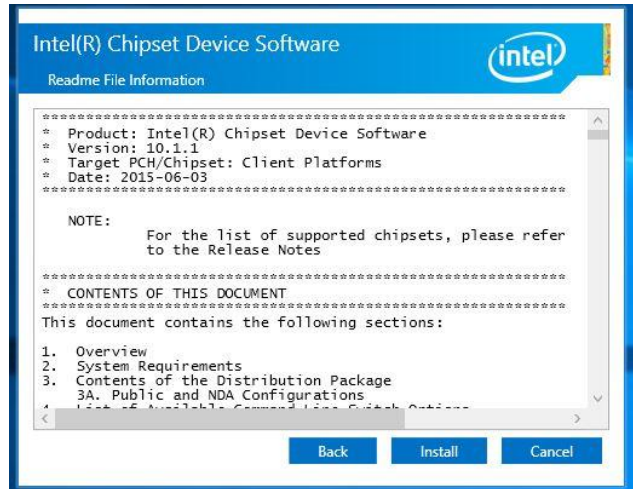

**Step 3.** Click **Install** to complete setup.



**Step1.** Click **Next**.



**Step 2.** Click **Accept**.

## 4.2 Install Display Driver

Insert the Supporting DVD-ROM to DVD-ROM drive, and it should show the index page of Avalue's products automatically. If not, locate Index.htm and choose the product from the menu left, or link to **WGAESM-SKLA**.



**Note:** The installation procedures and screen shots in this section are based on Windows 8 operation system.

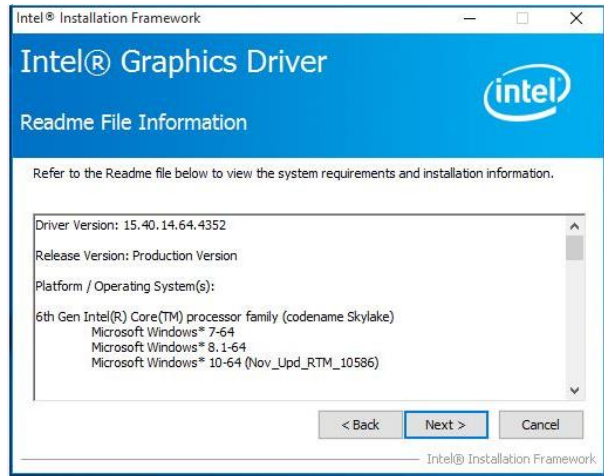

**Step 3.** Click **Next** to complete setup.

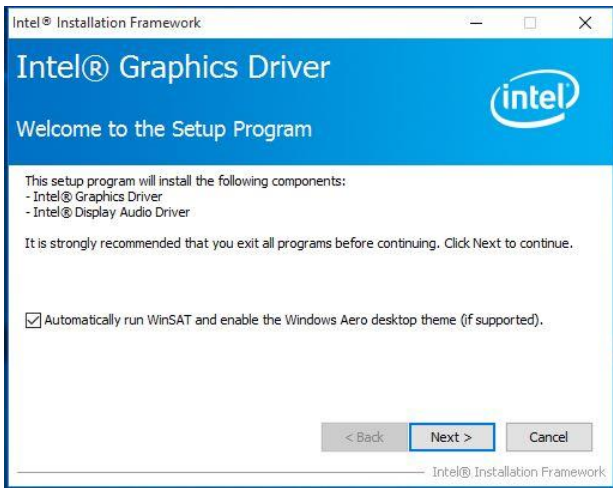

**Step 1.** Click **Next** to continue installation.

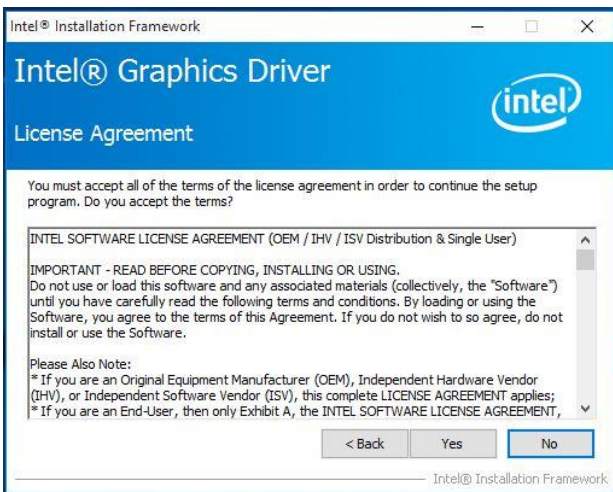

**Step 2.** Click **Yes** to accept license agreement.



## 4.3 Install LAN Driver (For Intel I219LM)

Insert the Supporting DVD-ROM to DVD-ROM drive, and it should show the index page of Avalue's products automatically. If not, locate Index.htm and choose the product from the menu left, or link to

**\Driver\_Gigabit\Intel\I219LM\ESM-SKLA\_LAN.**



**Note:** The installation procedures and screen shots in this section are based on Windows 8 operation system.

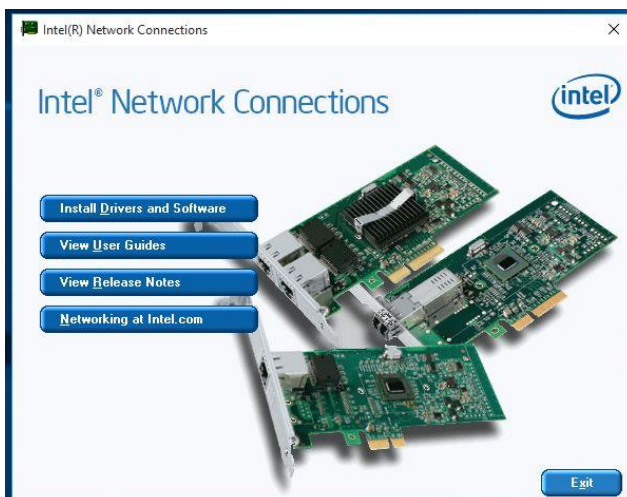

**Step 1. Click Install Drivers and Software.**

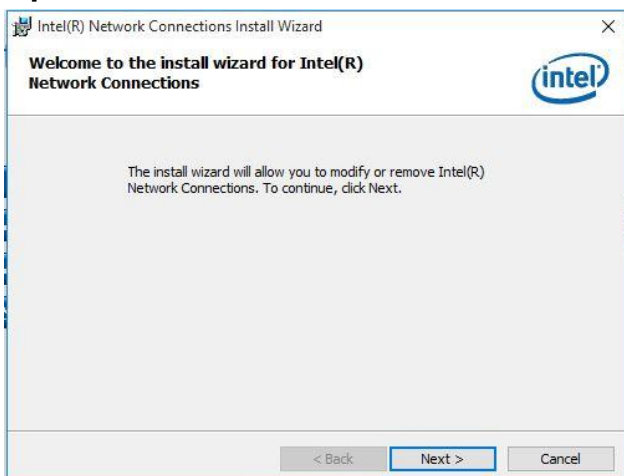

**Step 2. Click Next to complete setup.**

## 4.4 Install ME Driver

Insert the Supporting DVD-ROM to DVD-ROM drive, and it should show the index page of Avalue's products automatically. If not, locate Index.htm and choose the product from the menu left, or link to `\\Utility\ESM-SKLA_ME`.



**Note:** The installation procedures and screen shots in this section are based on Windows 8 operation system. If the warning message appears while the installation process, click Continue to go on.

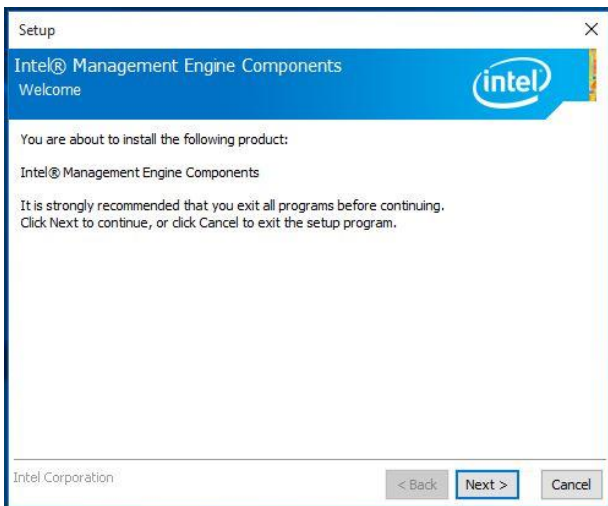

**Step1.** Click **Next** to start installation.



**Step 2.** Click **Next** to complete setup.

# 5. Mechanical Drawing

---

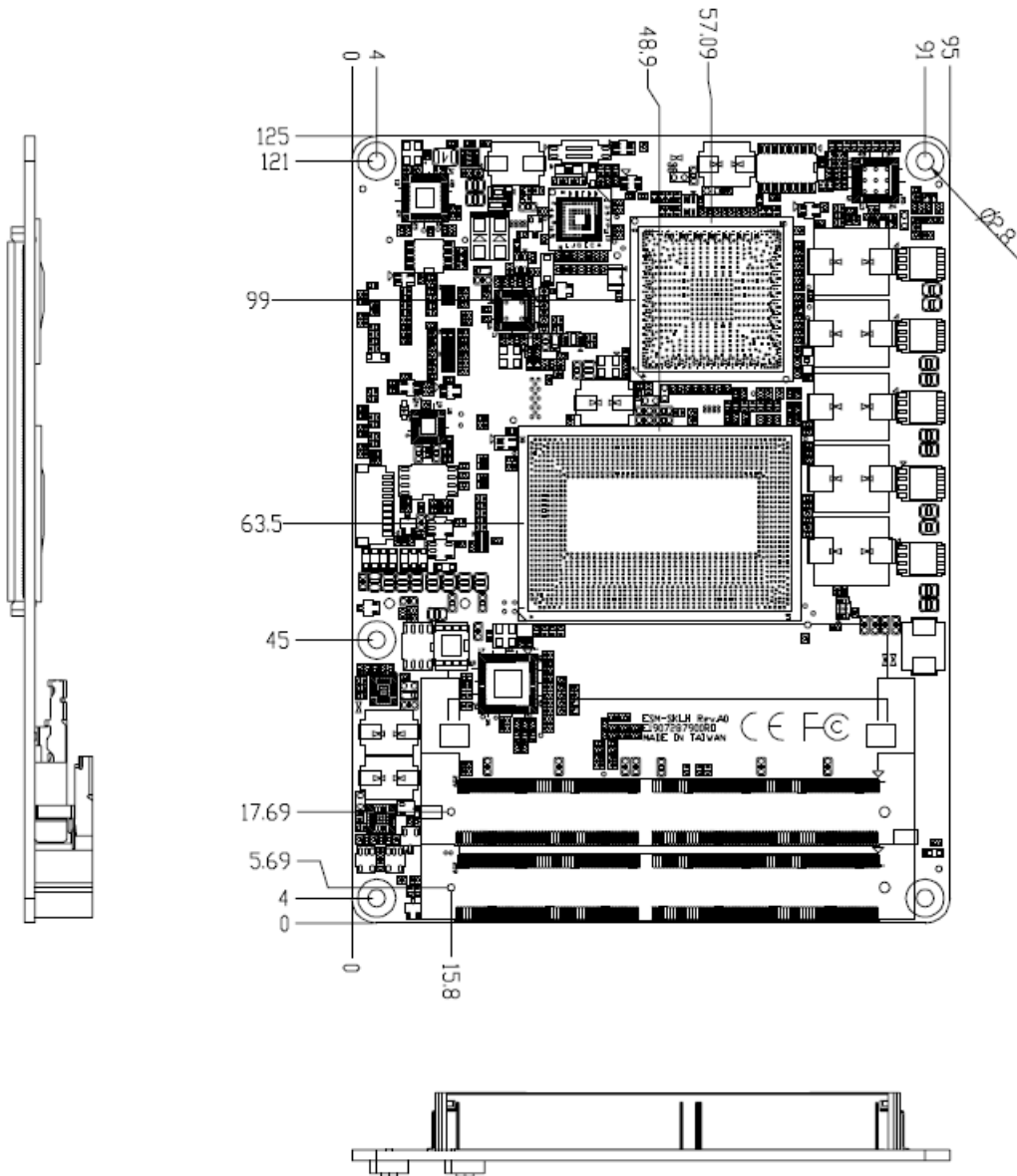

Unit: mm

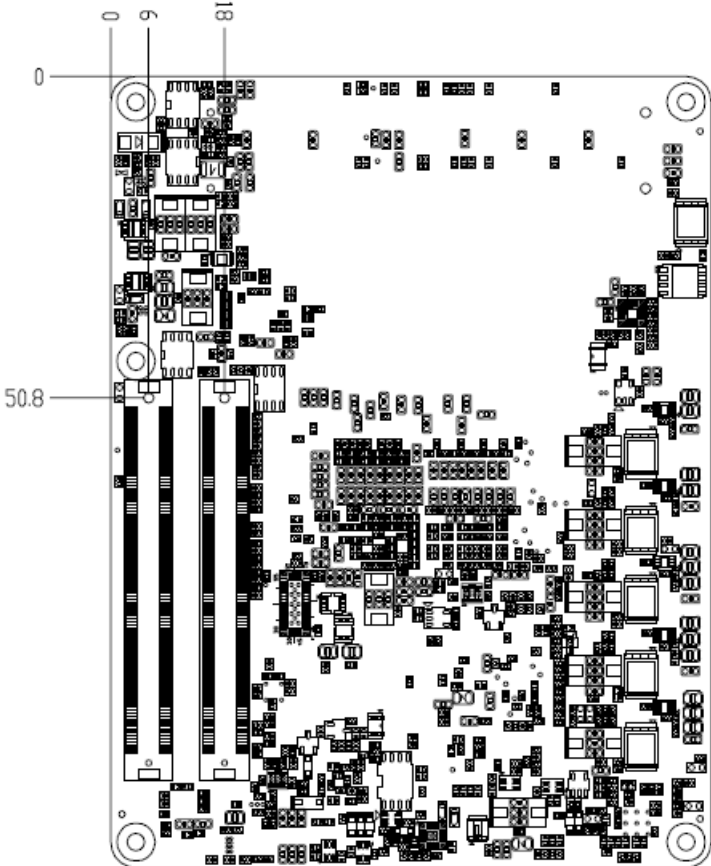

Unit: mm

