

# EMX-Q170KP

Intel® Core™ Processors with Intel® Q170 Mini ITX  
Motherboard

## User's Manual

---

3<sup>rd</sup> Ed – 05 February 2021

## FCC Statement



THIS DEVICE COMPLIES WITH PART 15 FCC RULES. OPERATION IS SUBJECT TO THE FOLLOWING TWO CONDITIONS:

- (1) THIS DEVICE MAY NOT CAUSE HARMFUL INTERFERENCE.
- (2) THIS DEVICE MUST ACCEPT ANY INTERFERENCE RECEIVED INCLUDING INTERFERENCE THAT MAY CAUSE UNDESIRE OPERATION.

THIS EQUIPMENT HAS BEEN TESTED AND FOUND TO COMPLY WITH THE LIMITS FOR A CLASS "A" DIGITAL DEVICE, PURSUANT TO PART 15 OF THE FCC RULES.

THESE LIMITS ARE DESIGNED TO PROVIDE REASONABLE PROTECTION AGAINST HARMFUL INTERFERENCE WHEN THE EQUIPMENT IS OPERATED IN A COMMERCIAL ENVIRONMENT. THIS EQUIPMENT GENERATES, USES, AND CAN RADIATE RADIO FREQUENCY ENERGY AND, IF NOT INSTALLED AND USED IN ACCORDANCE WITH THE INSTRUCTION MANUAL, MAY CAUSE HARMFUL INTERFERENCE TO RADIO COMMUNICATIONS.

OPERATION OF THIS EQUIPMENT IN A RESIDENTIAL AREA IS LIKELY TO CAUSE HARMFUL INTERFERENCE IN WHICH CASE THE USER WILL BE REQUIRED TO CORRECT THE INTERFERENCE AT HIS OWN EXPENSE.

## Notice

This guide is designed for experienced users to setup the system within the shortest time. For detailed information, please always refer to the electronic user's manual.

## Copyright Notice

Copyright © 2021 Avalue Technology Inc., ALL RIGHTS RESERVED.

No part of this document may be reproduced, copied, translated, or transmitted in any form or by any means, electronic or mechanical, for any purpose, without the prior written permission of the original manufacturer.

## Trademark Acknowledgement

Brand and product names are trademarks or registered trademarks of their respective owners.

## Disclaimer

Avalue Technology Inc. reserves the right to make changes, without notice, to any product, including circuits and/or software described or contained in this manual in order to improve design and/or performance. Avalue Technology assumes no responsibility or liability for the use of the described product(s), conveys no license or title under any patent, copyright, or masks work rights to these products, and makes no representations or warranties that

these products are free from patent, copyright, or mask work right infringement, unless otherwise specified. Applications that are described in this manual are for illustration purposes only. Avalue Technology Inc. makes no representation or warranty that such application will be suitable for the specified use without further testing or modification.

### Life Support Policy

Avalue Technology's PRODUCTS ARE NOT FOR USE AS CRITICAL COMPONENTS IN LIFE SUPPORT DEVICES OR SYSTEMS WITHOUT THE PRIOR WRITTEN APPROVAL OF Avalue Technology Inc.

As used herein:

1. Life support devices or systems are devices or systems which, (a) are intended for surgical implant into body, or (b) support or sustain life and whose failure to perform, when properly used in accordance with instructions for use provided in the labeling, can be reasonably expected to result in significant injury to the user.
2. A critical component is any component of a life support device or system whose failure to perform can be reasonably expected to cause the failure of the life support device or system, or to affect its safety or effectiveness.

### A Message to the Customer

#### *Avalue Customer Services*

Each and every Avalue's product is built to the most exacting specifications to ensure reliable performance in the harsh and demanding conditions typical of industrial environments. Whether your new Avalue device is destined for the laboratory or the factory floor, you can be assured that your product will provide the reliability and ease of operation for which the name Avalue has come to be known.

Your satisfaction is our primary concern. Here is a guide to Avalue's customer services. To ensure you get the full benefit of our services, please follow the instructions below carefully.

#### *Technical Support*

We want you to get the maximum performance from your products. So if you run into technical difficulties, we are here to help. For the most frequently asked questions, you can easily find answers in your product documentation. These answers are normally a lot more detailed than the ones we can give over the phone. So please consult the user's manual first.

To receive the latest version of the user's manual; please visit our Web site at:

<http://www.avalue.com.tw/>

## EMX-Q170KP User's Manual

### *Product Warranty*

Avalue warrants to you, the original purchaser, that each of its products will be free from defects in materials and workmanship for two years from the date of purchase.

This warranty does not apply to any products which have been repaired or altered by persons other than repair personnel authorized by Avalue, or which have been subject to misuse, abuse, accident or improper installation. Avalue assumes no liability under the terms of this warranty as a consequence of such events. Because of Avalue's high quality-control standards and rigorous testing, most of our customers never need to use our repair service. If any of Avalue's products is defective, it will be repaired or replaced at no charge during the warranty period. For out-of-warranty repairs, you will be billed according to the cost of replacement materials, service time, and freight. Please consult your dealer for more details. If you think you have a defective product, follow these steps:

1. Collect all the information about the problem encountered. (For example, CPU type and speed, Avalue's products model name, hardware & BIOS revision number, other hardware and software used, etc.) Note anything abnormal and list any on-screen messages you get when the problem occurs.
2. Call your dealer and describe the problem. Please have your manual, product, and any helpful information available.
3. If your product is diagnosed as defective, obtain an RMA (return material authorization) number from your dealer. This allows us to process your good return more quickly.
4. Carefully pack the defective product, a complete Repair and Replacement Order Card and a photocopy proof of purchase date (such as your sales receipt) in a shippable container. A product returned without proof of the purchase date is not eligible for warranty service.
5. Write the RMA number visibly on the outside of the package and ship it prepaid to your dealer.

# Content

<b>1. Getting Started</b>	<b>8</b>
1.1 Safety Precautions	8
1.2 Packing List	8
1.3 Document Amendment History	9
1.4 Manual Objectives	10
1.5 System Specifications	11
1.6 Architecture Overview—Block Diagram	14
<b>2. Hardware Configuration</b>	<b>15</b>
2.1 Product Overview	16
2.2 Jumper and Connector List	17
2.3 Setting Jumpers & Connectors	19
2.3.1 Serial port 1 pin9 signal select (JRI1)	19
2.3.2 Serial port 2 pin9 signal select (JRI2)	19
2.3.3 AT/ATX Power Mode Select (JATATX1)	20
2.3.4 Clear CMOS (JCMOS1)	20
2.3.5 LCD Inverter connector (JBKL1)	21
2.3.6 Serial port 2/3/4/5/6 connector (JCOM2/3/4/5/6)	21
2.3.7 COM2 RS485/422 connector (JCOM2_422_485)	22
2.3.8 General purpose I/O connector (JDIO1)	22
2.3.9 SGPIO connector (JSGPIO1)	23
2.3.10 ATX Power connector (ATXPWR1)	23
2.3.11 USB 2.0 connector 1 (JUSB1)	24
2.3.12 USB 2.0 connector 2 (JUSB2)	24
2.3.13 USB 2.0 connector 3 (JUSB3)	25
2.3.14 Battery connector (JBAT1)	25
2.3.15 LVDS connector (JLVDS1)	26
2.3.16 Front Audio connector (JAUDIO2)	27
2.3.16.1 Signal Description –Audio connector 2 (JAUDIO2)	27
2.3.17 LPC connector (JLPC1)	28
2.3.18 SPI connector (JSPI1)	28
2.3.19 Amplifier connector (JSPK1)	29
2.3.20 Front panel setting connector (JFP1)	29
2.3.21 LAN1& LAN 2 active LED connector (JLANLED1)	30
2.3.22 CPU fan connector (CPUFAN1)	30
2.3.23 System fan connector (SYSFAN1)	31
2.3.24 ATX 12V power connector (ATX12V1)	31

## EMX-Q170KP User's Manual

2.3.25	Gigabit LAN (RJ-45) connector (LAN1/2)	32
<b>3</b>	<b>BIOS Setup</b>	<b>33</b>
3.1	Introduction	34
3.2	Starting Setup	34
3.3	Using Setup	35
3.4	Getting Help	36
3.5	In Case of Problems	36
3.6	BIOS setup	37
3.6.1	Main Menu	37
3.6.1.1	System Language	38
3.6.1.2	System Date	38
3.6.1.3	System Time	38
3.6.2	Advanced Menu	39
3.6.2.1	CPU Configuration	39
3.6.2.1.1	CPU – Power management Control	40
3.6.2.2	PCH-FW Configuration	41
3.6.2.2.1	Firmware Update Configuration	41
3.6.2.2.2	OEM Flags Settings	42
3.6.2.3	Trusted Computing	42
3.6.2.4	ACPI Settings	43
3.6.2.5	S5 RTC Wake Settings	44
3.6.2.6	Super IO Configuration	46
3.6.2.6.1	Serial Port 1 Configuration	47
3.6.2.6.2	Serial Port 2 Configuration	47
3.6.2.6.3	Serial Port 3 Configuration	48
3.6.2.6.4	Serial Port 4 Configuration	48
3.6.2.6.5	Serial Port 5 Configuration	49
3.6.2.6.6	Serial Port 6 Configuration	49
3.6.2.7	NCT6106D H/W Monitor	50
3.6.2.7.1	Smart Fan Configuration	50
3.6.2.8	Serial Port Console Redirection	51
3.6.2.8.1	COM1	51
3.6.2.9	Intel TXT Configuration	53
3.6.2.10	Network Stack Configuration	53
3.6.2.11	CSM Configuration	55
3.6.2.12	USB Configuration	56
3.6.3	Chipset	57
3.6.3.1	System Agent (SA) Configuration	58
3.6.3.1.1	Graphics Configuration	58
3.6.3.1.2	DMI/OPI Configuration	59

3.6.3.1.3	PEG Port Configuration .....	60
3.6.3.1.4	Memory Configuration .....	61
3.6.3.2	PCH-IO Configuration .....	62
3.6.3.2.1	PCI Express Configuration .....	62
3.6.3.2.2	SATA And RST Configuration .....	66
3.6.3.2.3	HD Audio Configuration .....	67
3.6.4	Security .....	68
3.6.4.1	Secure Boot menu .....	69
3.6.4.1.1	Key Management .....	69
3.6.5	Boot .....	70
3.6.6	Save and exit .....	71
3.6.6.1	Save Changes and Reset .....	71
3.6.6.2	Discard Changes and Reset .....	71
3.6.6.3	Restore Defaults .....	71
3.6.6.4	Launch EFI Shell from filesystem device .....	71
<b>4.</b>	<b>Drivers Installation .....</b>	<b>72</b>
4.1	Install Chipset Driver .....	73
4.2	Install VGA Driver .....	74
4.3	Install SOL Driver .....	75
4.4	Install Audio Driver (For Realtek ALC892 HD Audio) .....	76
4.5	Install LAN Driver .....	77
4.6	Install RST Driver .....	79
<b>5.</b>	<b>Mechanical Drawing .....</b>	<b>81</b>

# 1. Getting Started

## 1.1 Safety Precautions

### Warning!



Always completely disconnect the power cord from your chassis whenever you work with the hardware. Do not make connections while the power is on. Sensitive electronic components can be damaged by sudden power surges. Only experienced electronics personnel should open the PC chassis.

### Caution!



Always ground yourself to remove any static charge before touching the CPU card. Modern electronic devices are very sensitive to static electric charges. As a safety precaution, use a grounding wrist strap at all times. Place all electronic components in a static-dissipative surface or static-shielded bag when they are not in the chassis.

## 1.2 Packing List

Before you begin installing your single board, please make sure that the following materials have been shipped:

- 1 x EMX-Q170KP motherboard
- 2 x SATA cable
- 1 x I/O Shield



---

If any of the above items is damaged or missing, contact your retailer.

---



### 1.3 Document Amendment History

Revision	Date	By	Comment
1 <sup>st</sup>	June 2017	Avalue	Initial Release
2 <sup>nd</sup>	August 2017	Avalue	Update Setting Jumpers & Connectors
3 <sup>rd</sup>	February 2021	Avalue	Update System Specifications

### 1.4 Manual Objectives

This manual describes in details Avalue Technology EMX-Q170KP Single Board.

We have tried to include as much information as possible but we have not duplicated information that is provided in the standard IBM Technical References, unless it proved to be necessary to aid in the understanding of this board.

We strongly recommend that you study this manual carefully before attempting to set up EMX-Q170KP or change the standard configurations. Whilst all the necessary information is available in this manual we would recommend that unless you are confident, you contact your supplier for guidance.

Please be aware that it is possible to create configurations within the CMOS RAM that make booting impossible. If this should happen, clear the CMOS settings, (see the description of the Jumper Settings for details).

If you have any suggestions or find any errors regarding this manual and want to inform us of these, please contact our Customer Service department with the relevant details.

## 1.5 System Specifications

System	
<b>CPU</b>	Intel® LGA1151 Socket Supports 6/7th Generation Core™ i7/ i5/ i3 Processors (Max. TDP at 95W)
<b>BIOS</b>	AMI uEFI BIOS, 128Mbit SPI Flash ROM
<b>System Chipset</b>	Intel® Q170 Express Chipset
<b>I/O Chip</b>	Nuvoton® NCT6106D
<b>System Memory</b>	Two 260-pin DDR4 2400MHz SO-DIMM socket, supports up to 32GB Max
<b>Watchdog Timer</b>	H/W Reset, 5 ~ 255 seconds/5 ~ 255 minutes (*1)
<b>H/W Status Monitor</b>	CPU temperature monitoring Voltages monitoring CPU fan speed control
<b>Expansion</b>	1 x PCI-e x 16 1 x Full Size Mini-PCI-e with mSATA Support (SATA III) 1 x Half Size Mini PCI-e
<b>S3/S4</b>	Yes (S0/S3/S4/S5)
I/O	
<b>USB</b>	4 x USB 3.0, 8 x USB 2.0
<b>GPIO</b>	8-bit GPIO
Display	
<b>Chipset</b>	Intel® Q170 Express chipset
<b>Resolution</b>	VGA: 2048 x 1536@50 Hz HDMI: 4096 x 2160@24 Hz, 2560 x 1600@60 Hz DP: 4096 x 2304@60Hz
<b>Multiple Display</b>	Triple Display
<b>HDMI</b>	HDMI: 3840 x 2160@30 Hz, 2560 x 1600@30 Hz
<b>LCD Interface</b>	Dual channel 18/24-bits LVDS (Chrontel CH7511B to LVDS) or eDP (optional)
Audio	
<b>Audio Codec</b>	Realtek ALC892 HD Audio Decoding Controller
<b>Audio Amp</b>	2 x 6W Amplifier
Ethernet	
<b>LAN Chip</b>	1 x Intel® I219LM Gigabit Ethernet PHY 1 x Intel® I211AT PCI-e Gigabit Ethernet
<b>Ethernet Interface</b>	Gigabit Ethernet
Internal I/O Connectors	
<b>Fan</b>	1 x 1 x 4 pin, pitch 2.54mm CPU fan connector with smart fan function supported

## EMX-Q170KP User's Manual

<b>Buzzer</b>	Onboard
<b>CMOS Battery</b>	1 x 2 Pin Pitch 1.25mm Vertical type battery connector
<b>Power ON</b>	1 x 2 x 5 pin, pitch 2.54mm connector for front panel
<b>Audio</b>	1 x 2 x 5 pin, pitch 2.54mm connector for front Audio
<b>Internal I/O Connector</b>	<p>Storage:</p> <p>1 x SATA III or 1 x full size Mini PCI-e support mSATA by BIOS selection</p> <p>5 x SATA III</p> <p>Onboard Infineon SLB9665 support TPM 2.0</p> <p>COM 1 pin9 power selection:</p> <p>1 x 2 x 3 pin, pitch 2.00mm connector for COM1 support RS232 with Pin 9,+5V/+12V/RI</p> <p>COM 2:</p> <p>1 x 2 x 3 pin, pitch 2.00mm connector for COM2 support RS232 with Pin 9,+5V/+12V/RI</p> <p>1 x 2 x 3 pin, pitch 2.00mm connector for COM2 support RS422/485 connector, Pin 5 with +5V</p> <p>COM 2: - 1 x 2 x 5 pin, pitch 2.00mm connector for COM2 support RS-232 connector</p> <p>COM3~6:</p> <p>4 x 2 x 5 pin, pitch 2.00mm connector for COM3~6: support RS-232 connector</p> <p>3 x 2 x 5 pin, pitch 2.54mm connector for 6 USB 2.0</p> <p>1 x 2 x 20 pin, pitch 1.25mm connector for LVDS</p> <p>1 x 1 x 5 pin, pitch 2.00mm Wafer connector for LCD inverter backlight connector (5V/12V)</p> <p>1 x 1 x 4 pin, pitch 2.54mm CPU fan connector with smart fan function supported</p> <p>1 x 1 x 4 pin, pitch 2.54mm System fan connector with smart fan function supported</p> <p>1 x 2 x 5 pin, pitch 2.54mm connector for front panel</p> <p>2 x 1 x 2 pin, pitch 2.00mm connector for LAN1 &amp; LAN2 Activity Indicator LED</p> <p>1 x 2 x 5 pin, pitch 2.54mm connector for front Audio</p> <p>1 x 4 pin, pitch wafer 2.00mm connector for 6W x 2 Speaker</p> <p>1 x 1 x 3 pin, pitch 2.54mm connector for COMS Clear</p> <p>1 x 2 pin Pitch 1.25mm Vertical type battery connector</p> <p>1 x 2 x 6 pin, pitch 2.00mm connector for 8 bits GPIO</p> <p>1 x 2 x 3 pin, pitch 2.00mm connector for SGPIO (Only support C236 PCH platform)</p> <p>1 x 2 x 4 pin, pitch 2.00mm connector for BIOS SPI</p> <p>1 x 2 x 5 pin, pitch 2.0mm connector for LPC</p> <p>Onboard buzzer</p> <p>1 x 1 x 3 pin pitch 2.00mm connector for AT/ATX jumper</p> <p>1 x 2 x 10 pin ATX power connector</p> <p>1 x 2 x 2 pin ATX 12V power connector</p>
<b>Rear I/O Connectors</b>	

<b>USB</b>	4 x USB3.0
<b>LAN</b>	1 x Intel® I219LM Gigabit Ethernet PHY 1 x Intel® I211AT PCI-e Gigabit Ethernet
<b>HDMI</b>	1 x HDMI
<b>Rear Side External I/O Connector</b>	2 x RJ-45 with Dual deck USB 3.0 connector 1 x VGA 1 x DP 1 x HDMI COM1 support RS-232 DB9 connector, Pin 9 with / +5V/+12V/RI Supported 1 x Line-out, 1 x Mic-In, 1 x Line-in 1 x PS/2 Keyboard or PS/2 Mouse with Dual deck USB 2.0
<b>Mechanical &amp; Environmental</b>	
<b>Power Requirement</b>	+12V/+5V/5VSB/+3.3V/-12V
<b>ACPI</b>	Single power ATX Support S0, S3, S4, S5
<b>Power on Type</b>	AT/ATX mode Switchable Through Jumper
<b>Operating Temp.</b>	0 ~ 60°C (32~140°F)
<b>Storage Temp.</b>	-40 ~ 75°C
<b>Operating Humidity</b>	0% ~ 90% relative humidity, non-condensing
<b>Size (L x W)</b>	6.7" x 6.7" (170mm x 170mm)
<b>Weight</b>	0.40 kg

**Note:**

Specifications are subject to change without notice.

## 1.6 Architecture Overview—Block Diagram

The following block diagram shows the architecture and main components of EMX-Q170KP.

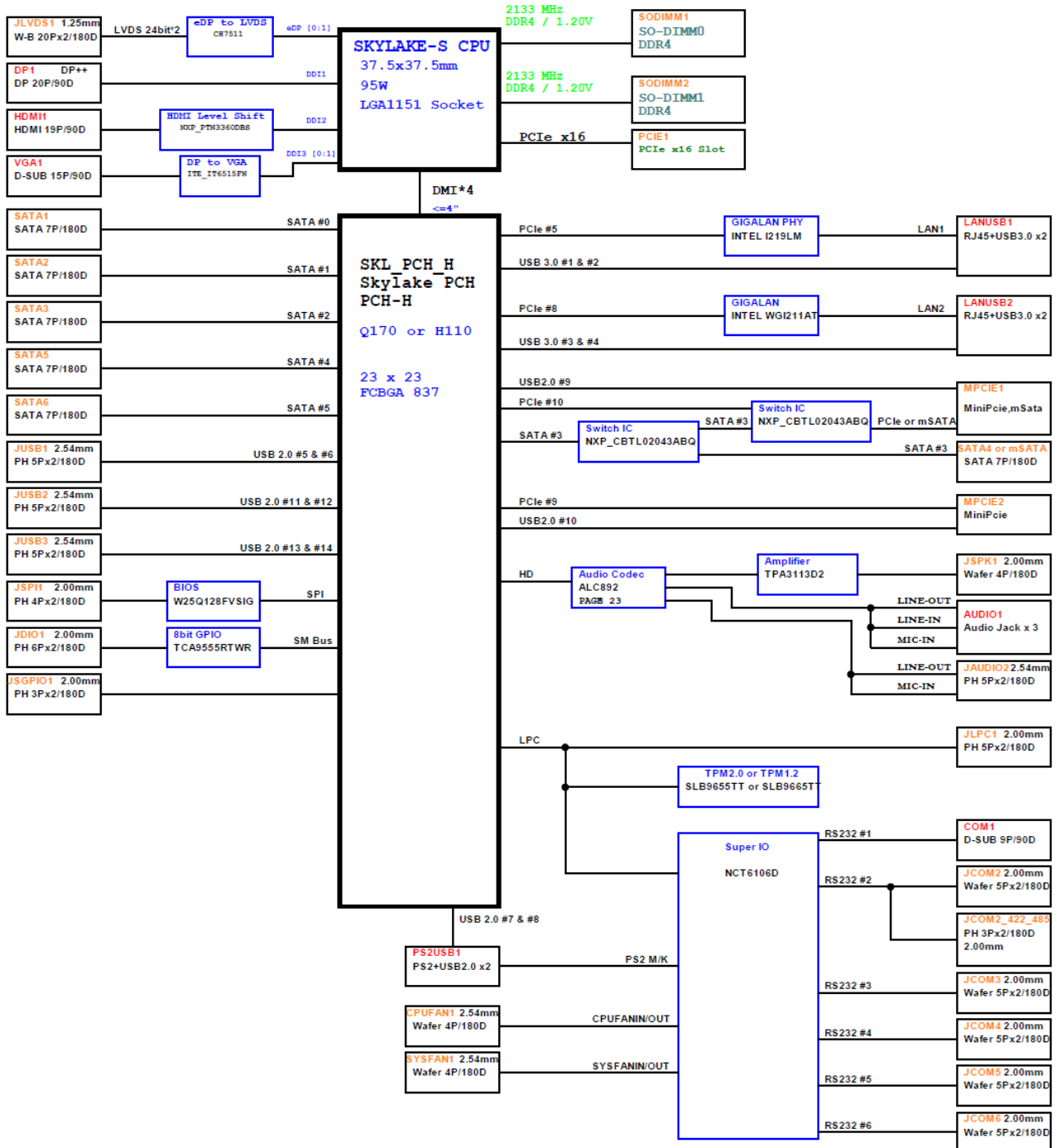

## 2. Hardware Configuration

---

## 2.1 Product Overview

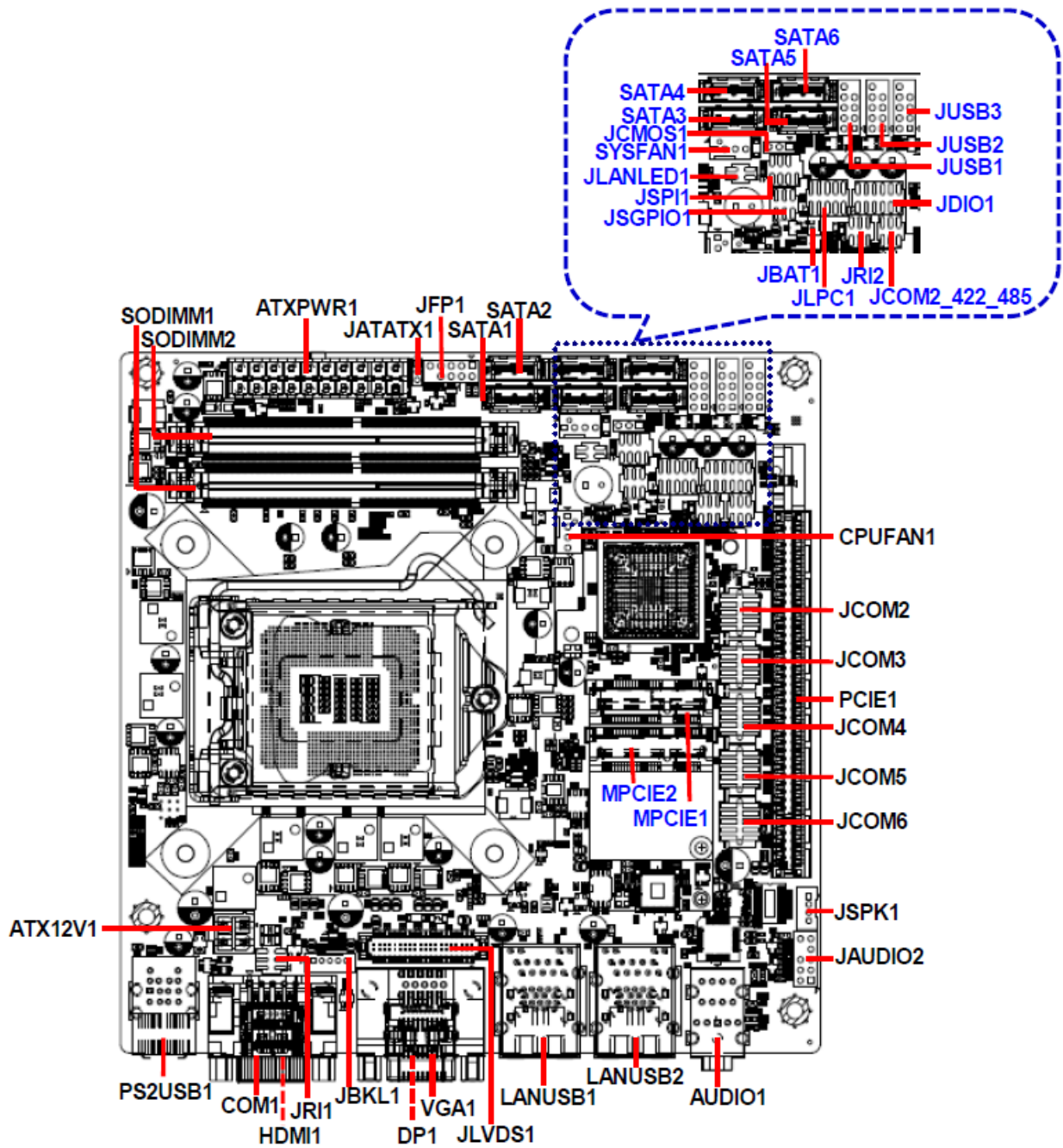



## 2.2 Jumper and Connector List

You can configure your board to match the needs of your application by setting jumpers. A jumper is the simplest kind of electric switch.

It consists of two metal pins and a small metal clip (often protected by a plastic cover) that slides over the pins to connect them. To “close” a jumper you connect the pins with the clip. To “open” a jumper you remove the clip. Sometimes a jumper will have three pins, labeled 1, 2, and 3. In this case, you would connect either two pins.

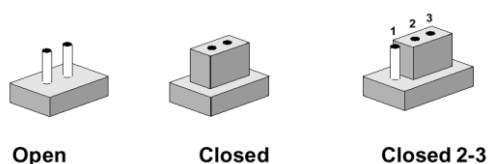

The jumper settings are schematically depicted in this manual as follows:



A pair of needle-nose pliers may be helpful when working with jumpers.

Connectors on the board are linked to external devices such as hard disk drives, a keyboard, or floppy drives. In addition, the board has a number of jumpers that allow you to configure your system to suit your application.

If you have any doubts about the best hardware configuration for your application, contact your local distributor or sales representative before you make any changes.

The following tables list the function of each of the board's jumpers and connectors.

### Jumpers

Label	Function	Note
JRI1/2	Serial port 1/2 pin9 signal select	3 x 2 header, pitch 2.00mm
JATATX1	AT/ATX Power Mode Select	3 x 1 header, pitch 2.00mm
JCMOS1	Clear CMOS	3 x 1 header, pitch 2.54mm

### Connectors

Label	Function	Note
CPUFAN1	CPU fan connector	4 x 1 wafer, pitch 2.54mm
SYSFAN1	System fan connector	4 x 1 wafer, pitch 2.54mm
JFP1	Front panel setting connector	5 x 2 header, pitch 2.54 mm
SODIMM1/2	260-pin DDR4 DIMM socket	
AUDIO1	Line out, Mic in, Line out	
JAUDIO2	Front Audio connector	5 x 2 header, pitch 2.54 mm

**EMX-Q170KP User's Manual**

<b>JBKL1</b>	LCD Inverter connector	5 x 1 wafer, pitch 2.00mm
<b>JSPI1</b>	SPI connector	4 x 2 header, pitch 2.00mm
<b>COM1</b>	Serial Port 1 connector	D-sub 9 pin, male
<b>JCOM2/3/4/5/6</b>	Serial Port 2/3/4/5/6 connector	5 x 2 wafer, pitch 2.00mm
<b>JCOM2_422_485</b>	COM2 RS485/422 connector	3 x 2 header, pitch 2.00 mm
<b>JDIO1</b>	General purpose I/O connector	6 x 2 header, pitch 2.00mm
<b>JSGPIO1</b>	SGPIO connector	3 x 2 header, pitch 2.00 mm
<b>JSPK1</b>	Amplifier connector	1 x 4 wafer, pitch 2.00 mm
<b>JLVDS1</b>	LVDS Connector	DIN 40-pin wafer, pitch 1.25mm
<b>PS2USB1</b>	PS/2 keyboard or mouse connector 2 x USB 2.0 connector	
<b>LANUSB1/2</b>	2 x RJ-45 with Dual deck USB 3.0 connector	
<b>JUSB1</b>	USB 2.0 connector 1	5 x 2 header, pitch 2.54mm
<b>JUSB2</b>	USB 2.0 connector 2	5 x 2 header, pitch 2.54mm
<b>JUSB3</b>	USB 2.0 connector 3	5 x 2 header, pitch 2.54mm
<b>JLPC1</b>	LPC connector	5 x 2 header, pitch 2.00mm
<b>PCIE1</b>	PCI-e x 16 connector	
<b>JLANLED1</b>	LAN1& LAN 2 active LED connector	2 x 2 header, pitch 2.00 mm
<b>JBAT1</b>	Battery connector	2 x 1 wafer, pitch 1.25mm
<b>MPCIE1/2</b>	Full size Mini-PCI-e connector 1 Half size Mini-PCI-e connector 2	
<b>ATXPWR1</b>	ATX Power connector	10 x 2 wafer, pitch 4.20mm
<b>ATX12V1</b>	ATX 12V power connector	2 x 2 wafer, pitch 4.20mm
<b>SATA1~6</b>	Serial ATA III connector 1~6	
<b>HDMI1</b>	HDMI connector	
<b>DP1</b>	DP connector	
<b>VGA1</b>	VGA connector	

## 2.3 Setting Jumpers & Connectors

### 2.3.1 Serial port 1 pin9 signal select (JRI1)

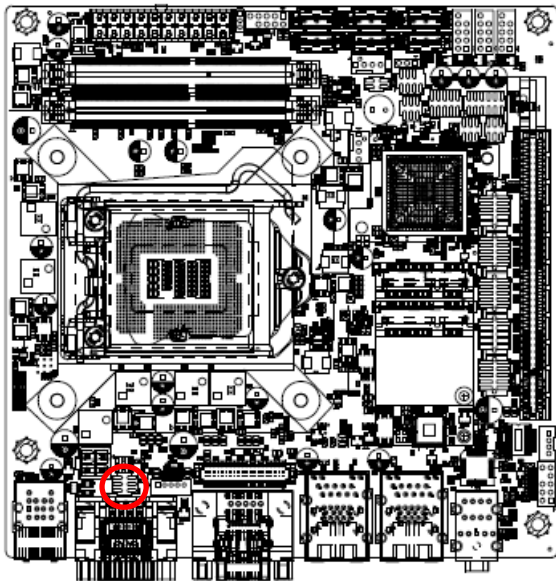

Ring\*

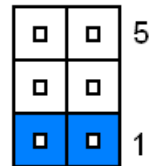

+5V

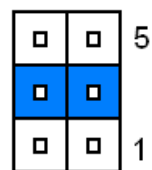

+12V

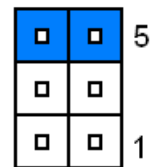

\* Default

**Note:**

Max Current 1A.

### 2.3.2 Serial port 2 pin9 signal select (JRI2)

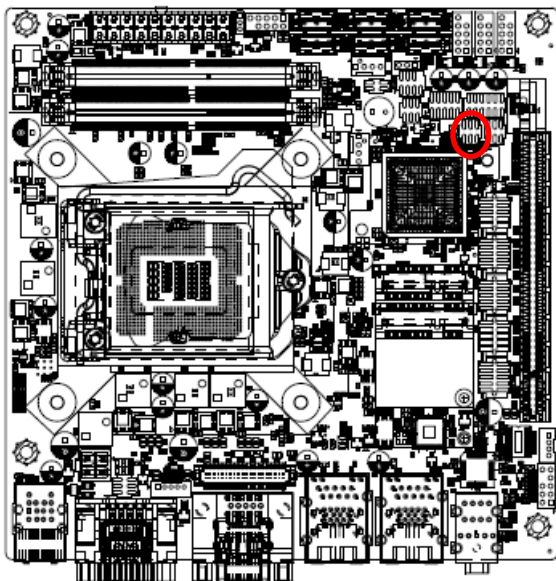

Ring\*

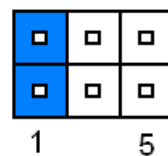

+5V

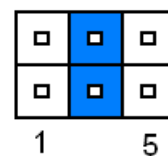

+12V

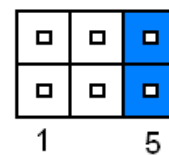

\* Default

**Note:**

Max Current 1A.

### 2.3.3 AT/ATX Power Mode Select (JATATX1)

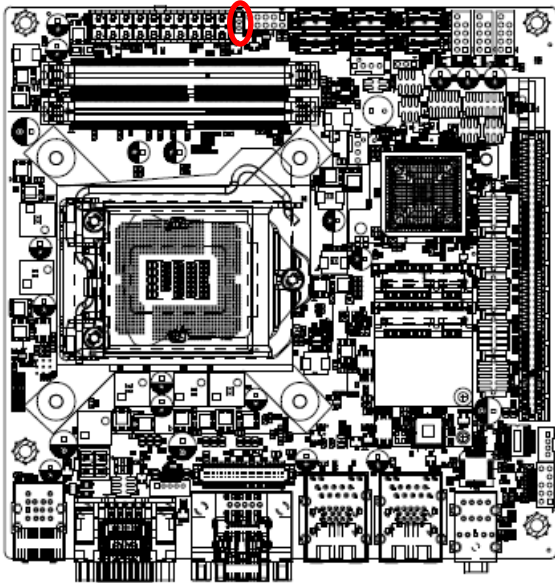

ATX\*

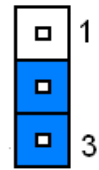

AT

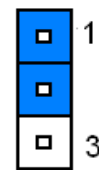

\* Default

### 2.3.4 Clear CMOS (JCMOS1)

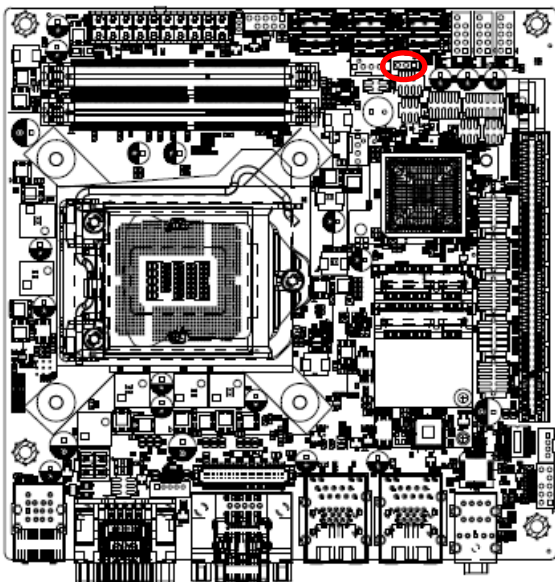

Protect\*

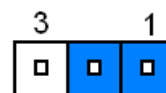

Clear CMOS

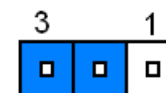

\* Default

### 2.3.5 LCD Inverter connector (JBKL1)

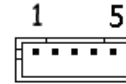
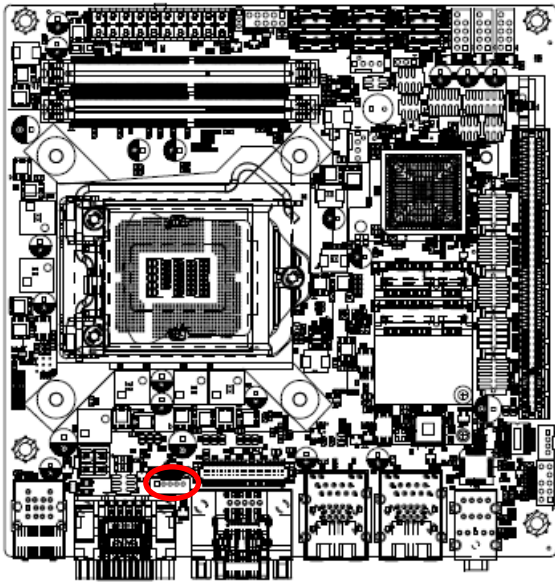

PIN	Signal	Max current
1	+12V	2A
2	GND	
3	BKLEN	
4	VBRIGHT	
5	+5V	2A

**Note:**

Mapping connector PHR5.

### 2.3.6 Serial port 2/3/4/5/6 connector (JCOM2/3/4/5/6)

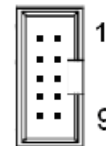
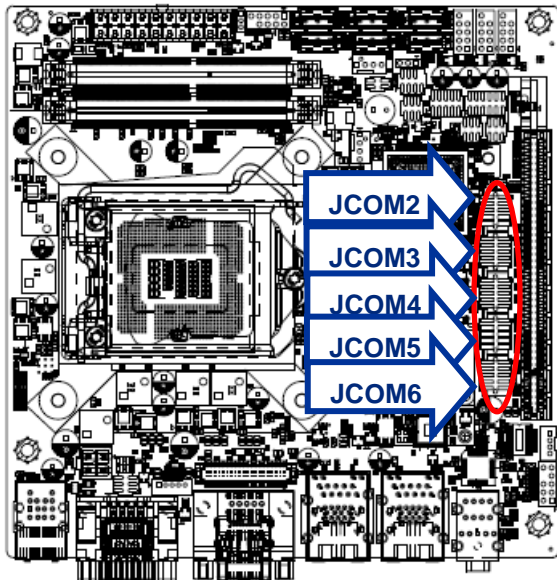

Signal	PIN	PIN	Signal
RXD	2	1	DCD
DTR	4	3	TXD
DSR	6	5	GND
CTS	8	7	RTS
NC	10	9	RI

2.3.7 COM2 RS485/422 connector (JCOM2\_422\_485)

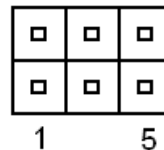
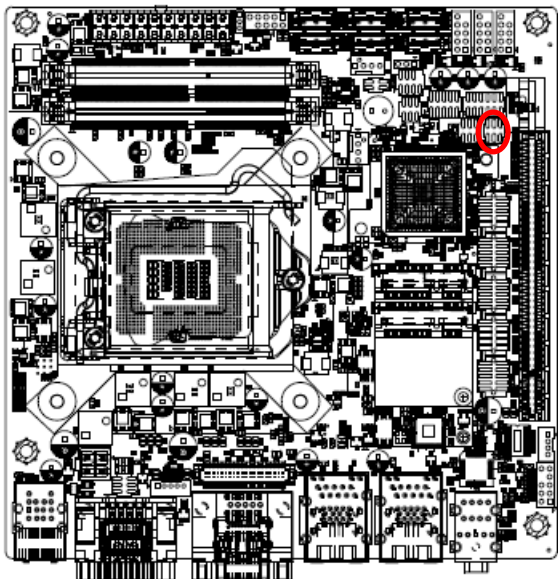

RS-422

Signal	PIN	PIN	Signal
422TX-	1	2	422RX-
422TX+	3	4	422RX+
+5V	5	6	GND

RS-485

Signal	PIN	PIN	Signal
DATA-	1	2	NC
DATA+	3	4	NC
+5V	5	6	GND

**Note:**

Max Current 1A.

2.3.8 General purpose I/O connector (JDIO1)

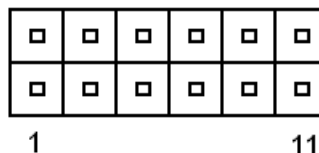
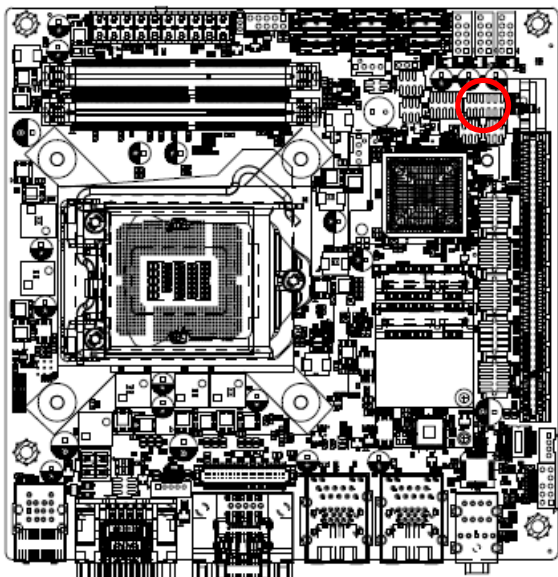

Signal	PIN	PIN	Signal
DI0	1	2	DO0
DI1	3	4	DO1
DI2	5	6	DO2
DI3	7	8	DO3
SMB_CLK_9555	9	10	SMB_DATA_9555
GND	11	12	+5V

**Note:**

Max Current 1A.

### 2.3.9 SGPIO connector (JSGPIO1)

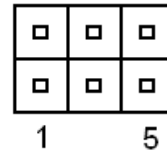
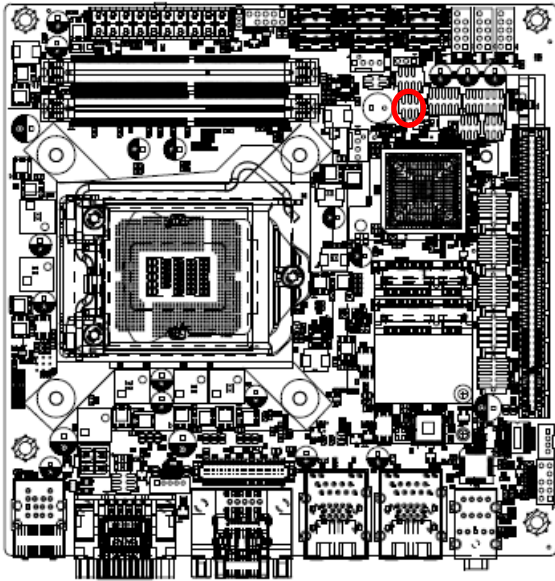

Signal	PIN	PIN	Signal
GND	1	2	GND
SGIO_LOAD	3	4	SGIO_DATOUT0
SGIO_CLK	5	6	SGIO_DATOUT1

### 2.3.10 ATX Power connector (ATXPWR1)

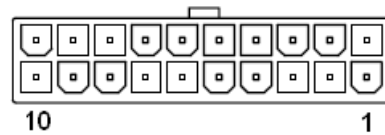
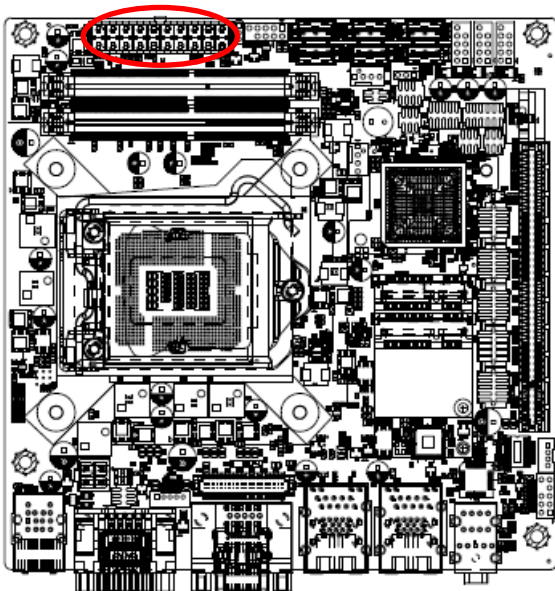

Signal	PIN	PIN	Signal
+3.3V	1	11	+3.3V
+3.3V	2	12	-12V
GND	3	13	GND
+5V	4	14	PSON#
GND	5	15	GND
+5V	6	16	GND
GND	7	17	GND
PG_ATX	8	18	-5V
+V5SB_DP	9	19	+5V
+12V	10	20	+5V

2.3.11 USB 2.0 connector 1 (JUSB1)

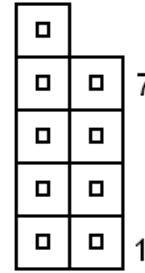
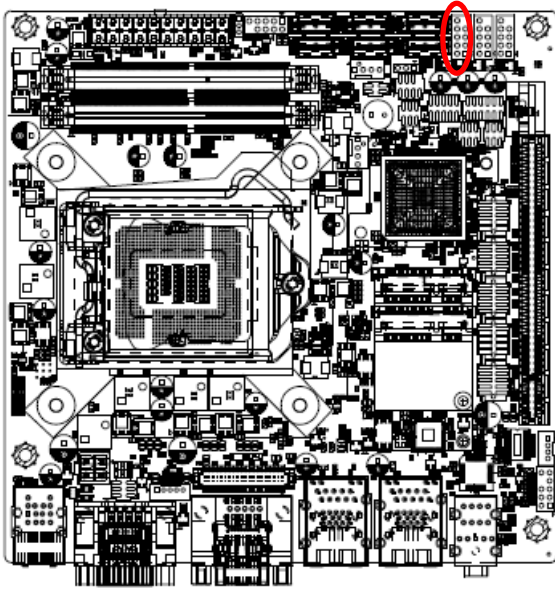

Signal	PIN	PIN	Signal
NC	10		
GND	8	7	GND
USB_R_DP6	6	5	USB_R_DP5
USB_R_DN6	4	3	USB_R_DN5
+5V	2	1	+5V

2.3.12 USB 2.0 connector 2 (JUSB2)

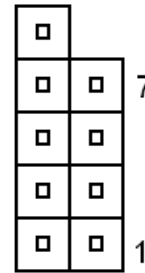
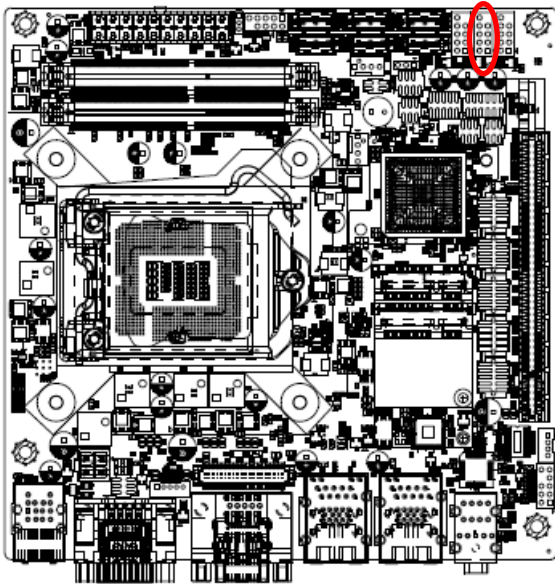

Signal	PIN	PIN	Signal
NC	10		
GND	8	7	GND
USB_R_DP12	6	5	USB_R_DP11
USB_R_DN12	4	3	USB_R_DN11
+5V	2	1	+5V



### 2.3.13 USB 2.0 connector 3 (JUSB3)

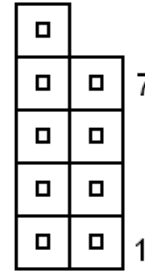
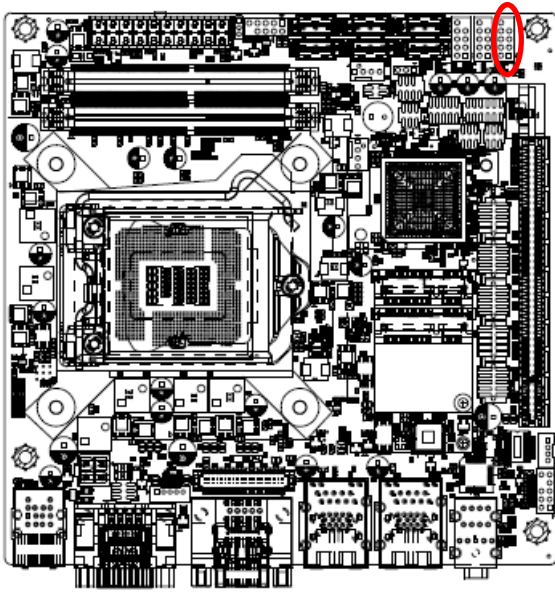

Signal	PIN	PIN	Signal
NC	10		
GND	8	7	GND
USB_R_DP14	6	5	USB_R_DP13
USB_R_DN14	4	3	USB_R_DN13
+5V	2	1	+5V

### 2.3.14 Battery connector (JBAT1)

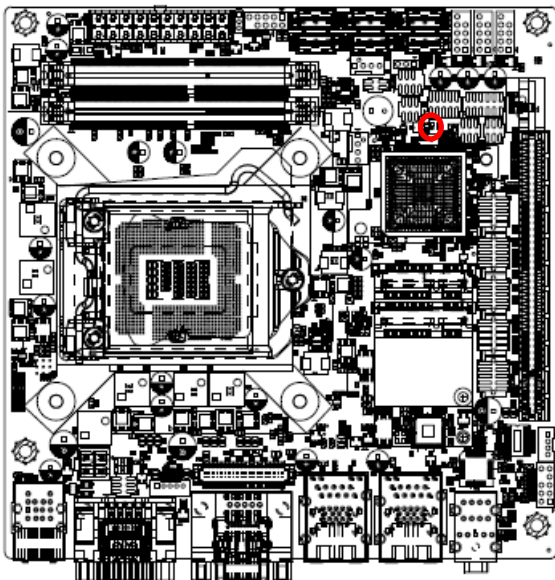

Signal	PIN
RTC_VBAT_1	1
GND	2

2.3.15 LVDS connector (JLVDS1)

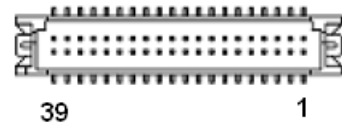
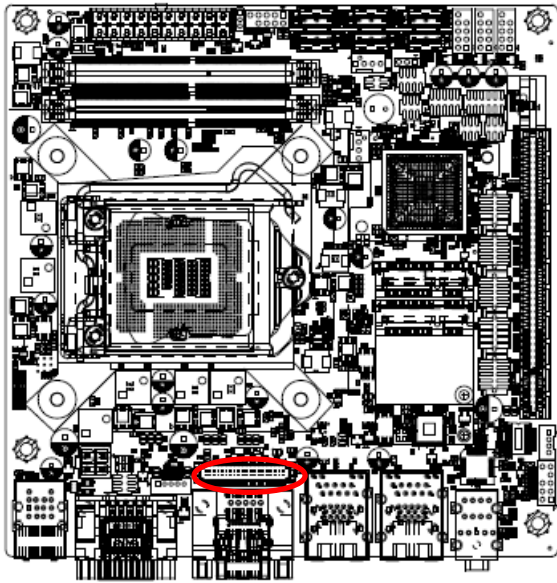

Signal	PIN	PIN	Signal
+5V	2	1	+3.3V
+5V	4	3	+3.3V
NC	6	5	NC
GND	8	7	GND
LVDS_DATA0_P	10	9	LVDS_DATA1_P
LVDS_DATA0_N	12	11	LVDS_DATA1_N
GND	14	13	GND
LVDS_DATA2_P	16	15	LVDS_DATA3_P
LVDS_DATA2_N	18	17	LVDS_DATA3_N
GND	20	19	GND
LVDS_DATA4_P	22	21	LVDS_DATA5_P
LVDS_DATA4_N	24	23	LVDS_DATA5_N
GND	26	25	GND
LVDS_DATA6_P	28	27	LVDS_DATA7_P
LVDS_DATA6_N	30	29	LVDS_DATA7_N
GND	32	31	GND
LVDS_CLK1_P	34	33	LVDS_CLK2_P
LVDS_CLK1_N	36	35	LVDS_CLK2_N
GND	38	37	GND
+12V	40	39	+12V

**Note:**

Mapping connector DF13-40DS-1.25C (1.0mm).

2.3.16 Front Audio connector (JAUDIO2)

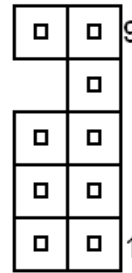
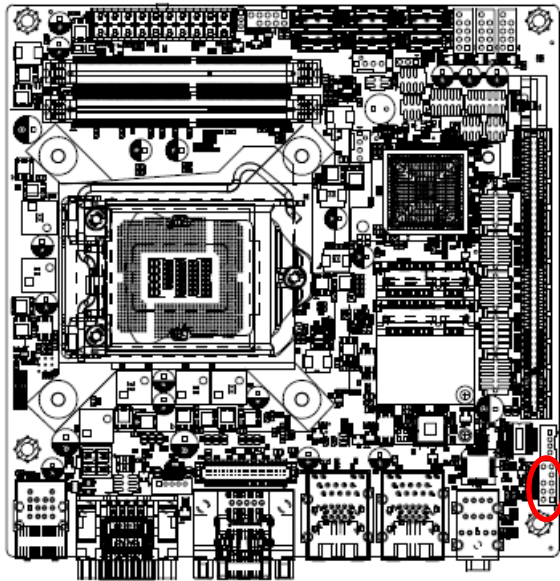

Signal	PIN	PIN	Signal
LINE2_JD	10	9	LINE2_LIN
		7	GND
MIC2_JD	6	5	LINE2_RIN
ACZ_DET#_R	4	3	MIC2_RIN
GND	2	1	MIC2_LIN

2.3.16.1 Signal Description –Audio connector 2 (JAUDIO2)

Signal	Signal Description
LINE2_JD	AUDIO IN (LINE_RIN/LIN)sense pin
MIC2_JD	MIC IN (MIC_RIN/LIN) sense pin

2.3.17 LPC connector (JLPC1)

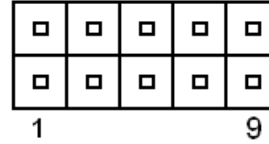
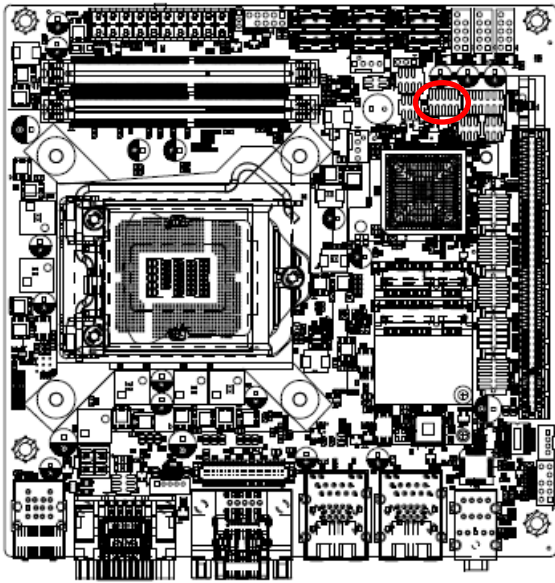

Signal	PIN	PIN	Signal
LPC_AD0	1	2	+3.3V
LPC_AD1	3	4	BUF_PLT_RST#
LPC_AD2	5	6	LPC_FRAME#
LPC_AD3	7	8	LPC_CLK
LPC_SERIRQ	9	10	GND

2.3.18 SPI connector (JSPI1)

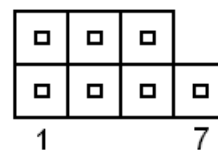
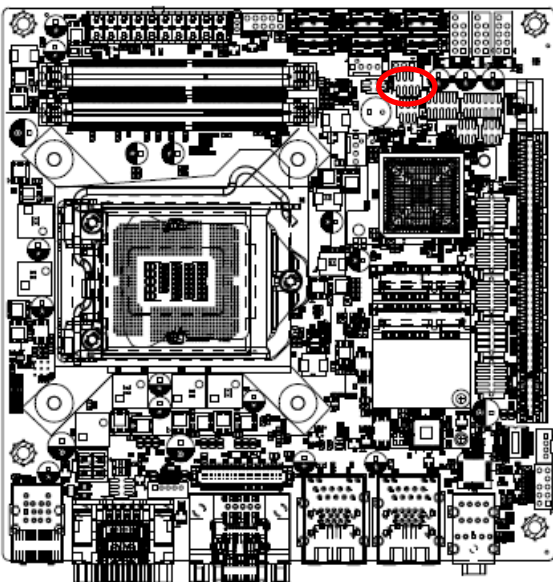

Signal	PIN	PIN	Signal
+3.3V	1	2	GND
SSPI_CS0#_R	3	4	SSPI_SCLK_R
SSPI_SO_R	5	6	SSPI_SI_R
SSPI_HOLD#0	7		

### 2.3.19 Amplifier connector (JSPK1)

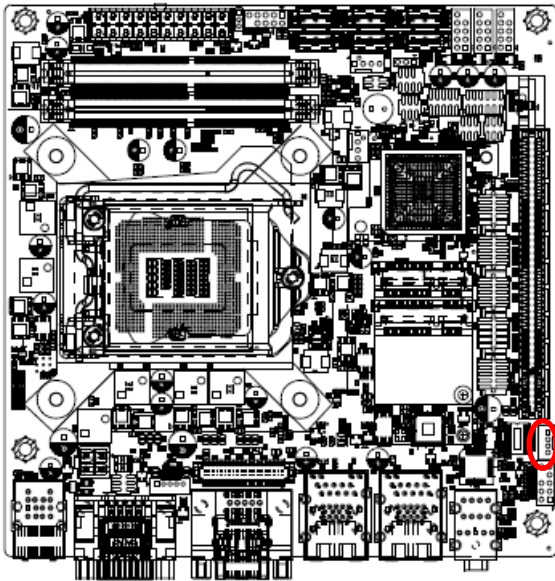

Signal	PIN
SPK_L+	1
SPK_L-	2
SPK_R+	3
SPK_R-	4

**Note:**

Support 6W x 2 speakers. Mapping Connector PHR-4.

### 2.3.20 Front panel setting connector (JFP1)

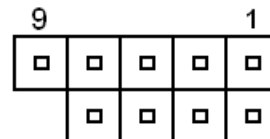
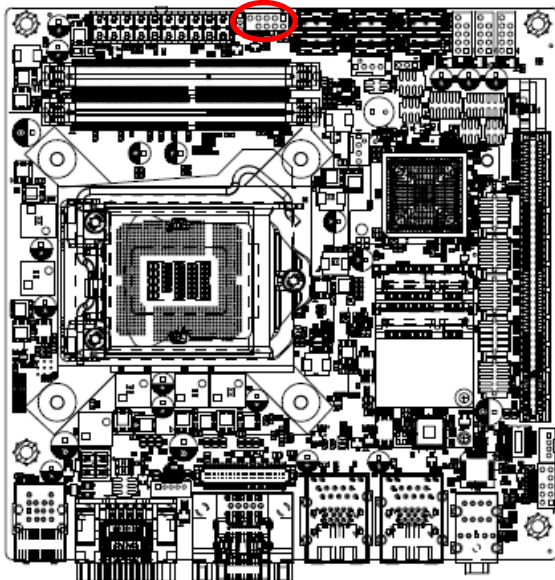

Signal	PIN	PIN	Signal
+HD_LED	1	2	+PWR_LED
-HD_LED	3	4	-PWE_LED
+Reset	5	6	+PWR_BNT
-Reset	7	8	-PWR_BNT
NC	9		

2.3.21 LAN1& LAN 2 active LED connector (JLANLED1)

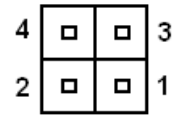
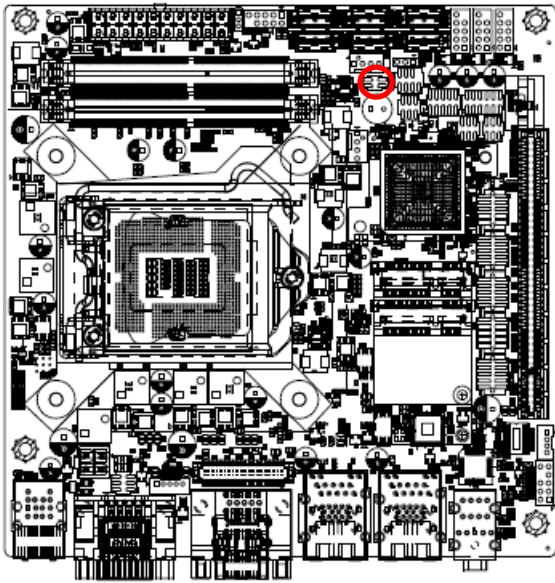

Signal	PIN	PIN	Signal
LAN2_ACT#	4	3	LAN1_ACT#
FRONT_LAN2_ACT	2	1	FRONT_LAN1_ACT

2.3.22 CPU fan connector (CPUFAN1)

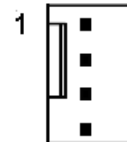
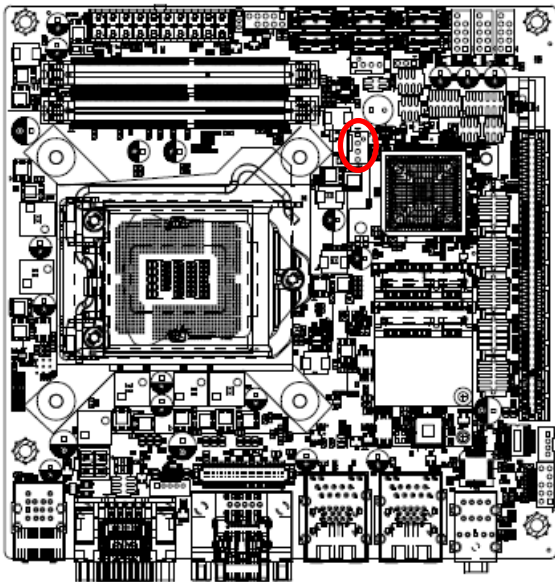

Signal	PIN
GND	1
+12V	2
CPUFANIN	3
CPUFANOUT	4

### 2.3.23 System fan connector (SYSFAN1)

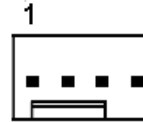
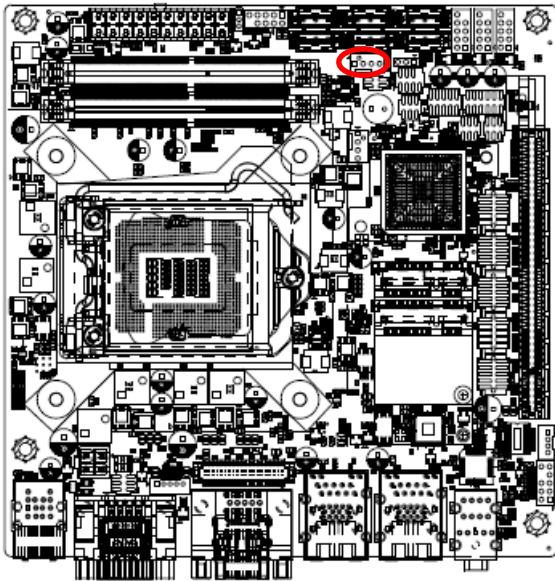

Signal	PIN
GND	1
+12V	2
SYSFANIN	3
SYSFANOUT	4

### 2.3.24 ATX 12V power connector (ATX12V1)

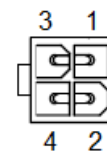
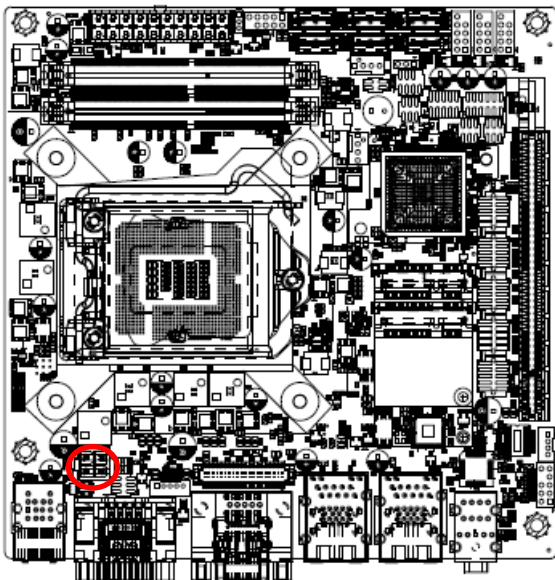

Signal	PIN	PIN	Signal
+12V	3	1	GND
+12V	4	2	GND

2.3.25 Gigabit LAN (RJ-45) connector (LAN1/2)

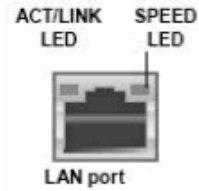
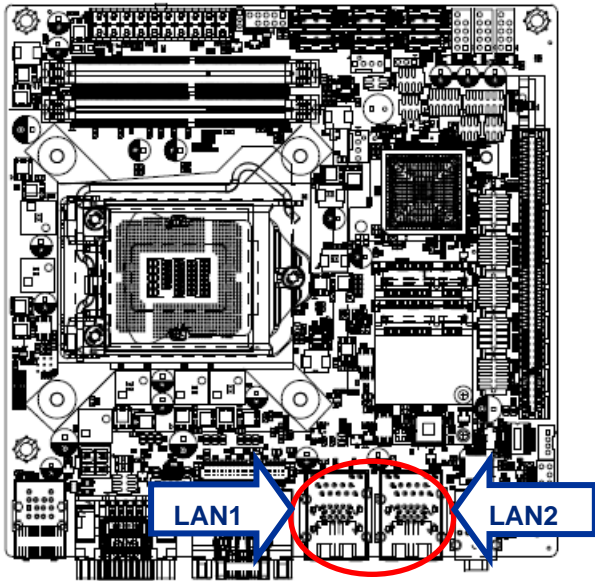

**Note:**

This port allows Gigabit connection to a Local Area Network (LAN) through a network hub. Refer to the table below for the LAN port LED indications.

ACT/LINK LED		SPEED LED	
Status	Description	Status	Description
OFF	No Light	OFF	10Mbps connection
Orange	Linked	Green	100Mbps connection
Blinking	Data activity	Orange	1Gbps connection



# 3. BIOS Setup

---

### 3.1 Introduction

The BIOS setup program allows users to modify the basic system configuration. In this following chapter will describe how to access the BIOS setup program and the configuration options that may be changed.

### 3.2 Starting Setup

The AMI BIOS™ is immediately activated when you first power on the computer. The BIOS reads the system information contained in the NVRAM and begins the process of checking out the system and configuring it. When it finishes, the BIOS will seek an operating system on one of the disks and then launch and turn control over to the operating system.

While the BIOS is in control, the Setup program can be activated in one of two ways:

By pressing <Del> or <F2> immediately after switching the system on, or

By pressing the <Del> or <F2> key when the following message appears briefly at the left-top of the screen during the POST (Power On Self Test).

**Press <Del> or <F2> to enter SETUP**

If the message disappears before you respond and you still wish to enter Setup, restart the system to try again by turning it OFF then ON or pressing the "RESET" button on the system case. You may also restart by simultaneously pressing <Ctrl>, <Alt>, and <Delete> keys. If you do not press the keys at the correct time and the system does not boot, an error message will be displayed and you will again be asked to.

**Press F1 to Continue, DEL to enter SETUP**

### 3.3 Using Setup

In general, you use the arrow keys to highlight items, press <Enter> to select, use the PageUp and PageDown keys to change entries, press <F1> for help and press <Esc> to quit. The following table provides more detail about how to navigate in the Setup program using the keyboard.

Button	Description
↑	Move to previous item
↓	Move to next item
←	Move to the item in the left hand
→	Move to the item in the right hand
Esc key	Main Menu -- Quit and not save changes into NVRAM Status Page Setup Menu and Option Page Setup Menu -- Exit current page and return to Main Menu
+ key	Increase the numeric value or make changes
- key	Decrease the numeric value or make changes
F1 key	General help, only for Status Page Setup Menu and Option Page Setup Menu
F2 key	Previous Values.
F3 key	Optimized defaults
F4 key	Save & Exit Setup

- **Navigating Through The Menu Bar**

Use the left and right arrow keys to choose the menu you want to be in.



**Note:** Some of the navigation keys differ from one screen to another.

- **To Display a Sub Menu**

Use the arrow keys to move the cursor to the sub menu you want. Then press <Enter>. A “>” pointer marks all sub menus.

### 3.4 Getting Help

Press F1 to pop up a small help window that describes the appropriate keys to use and the possible selections for the highlighted item. To exit the Help Window press <Esc> or the F1 key again.

### 3.5 In Case of Problems

If, after making and saving system changes with Setup, you discover that your computer no longer is able to boot, the AMI BIOS supports an override to the NVRAM settings which resets your system to its defaults.

The best advice is to only alter settings which you thoroughly understand. To this end, we strongly recommend that you avoid making any changes to the chipset defaults. These defaults have been carefully chosen by both BIOS Vendor and your systems manufacturer to provide the absolute maximum performance and reliability. Even a seemingly small change to the chipset setup has the potential for causing you to use the override.

### 3.6 BIOS setup

Once you enter the Aptio Setup Utility, the Main Menu will appear on the screen. The Main Menu allows you to select from several setup functions and exit choices. Use the arrow keys to select among the items and press <Enter> to accept and enter the sub-menu.

#### 3.6.1 Main Menu

This section allows you to record some basic hardware configurations in your computer and set the system clock.

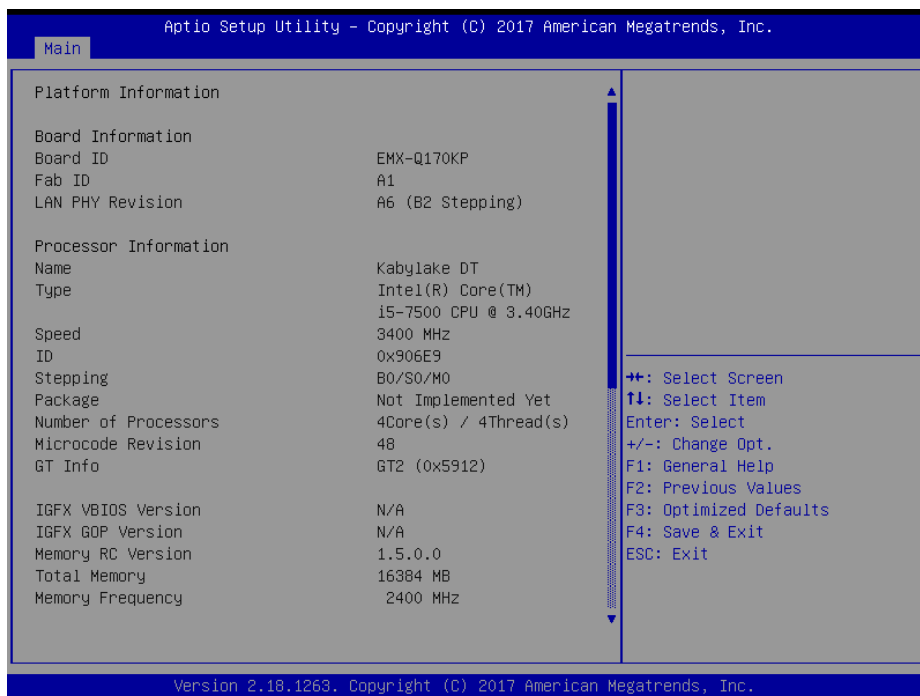
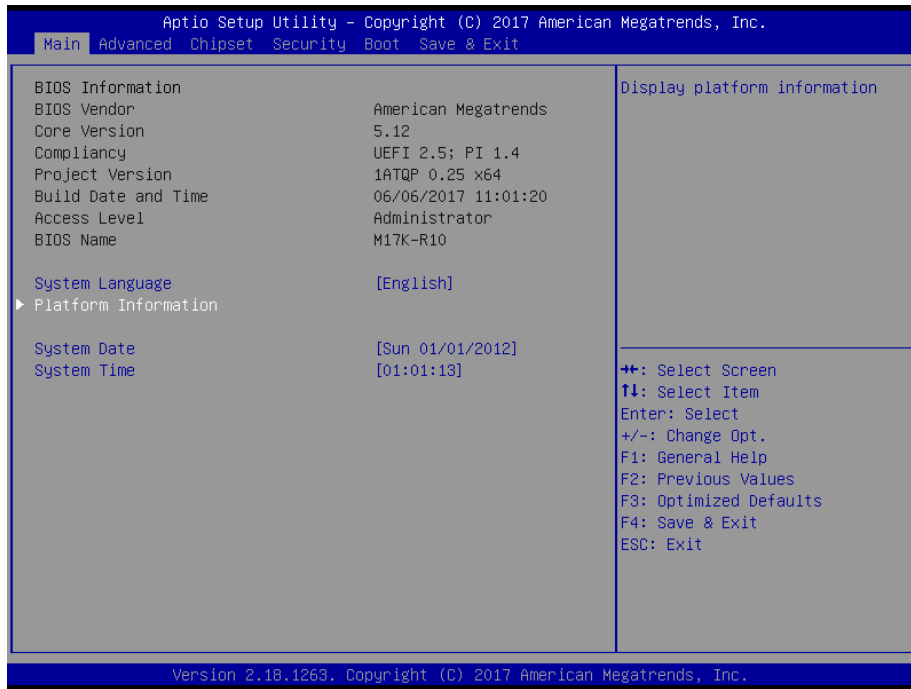

# EMX-Q170KP User's Manual

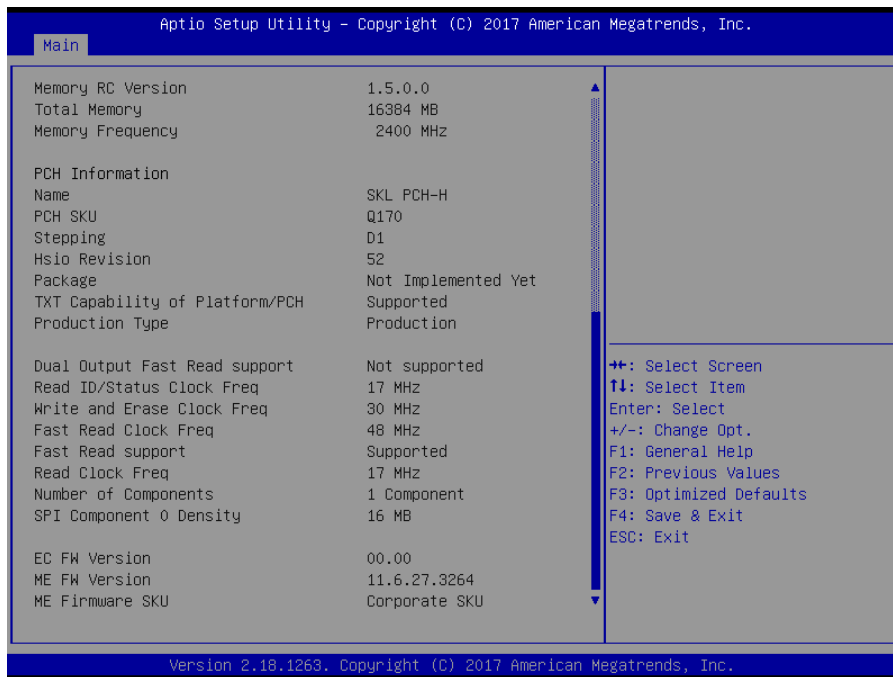

### 3.6.1.1 System Language

This option allows choosing the system default language.

### 3.6.1.2 System Date

Use the system date option to set the system date. Manually enter the day, month and year.

### 3.6.1.3 System Time

Use the system time option to set the system time. Manually enter the hours, minutes and seconds.



**Note:** The BIOS setup screens shown in this chapter are for reference purposes only, and may not exactly match what you see on your screen.

Visit the Avalue website ([www.avalue.com.tw](http://www.avalue.com.tw)) to download the latest product and BIOS information.

### 3.6.2 Advanced Menu

This section allows you to configure your CPU and other system devices for basic operation through the following sub-menus.

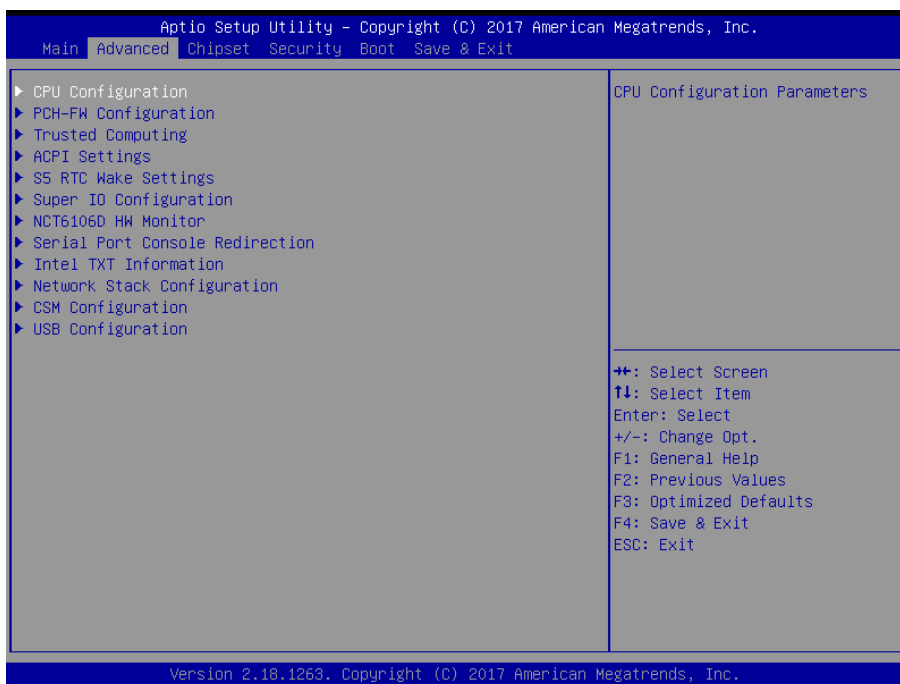

#### 3.6.2.1 CPU Configuration

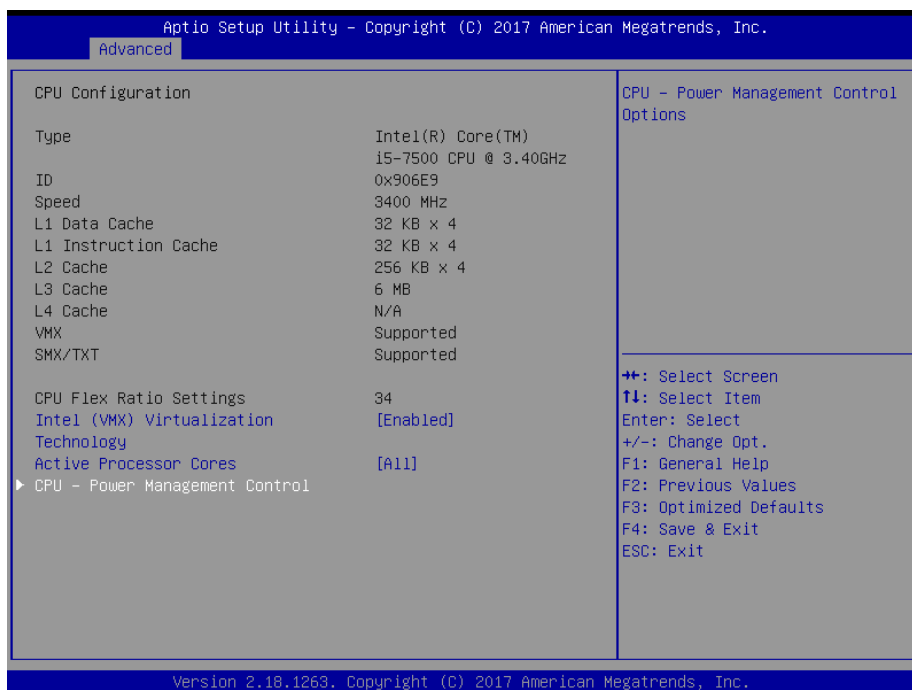

Item	Options	Description
<b>Intel (VMX) Virtualization Technology</b>	Disabled Enabled[Default],	When enabled, a VMM can utilize the additional hardware capabilities provided by Vanderpool Technology.

<b>Active Processor Cores</b>	All[Default], 1 2 3	Number of cores to enable in each processor package.
-------------------------------	------------------------------	--

3.6.2.1.1 CPU – Power management Control

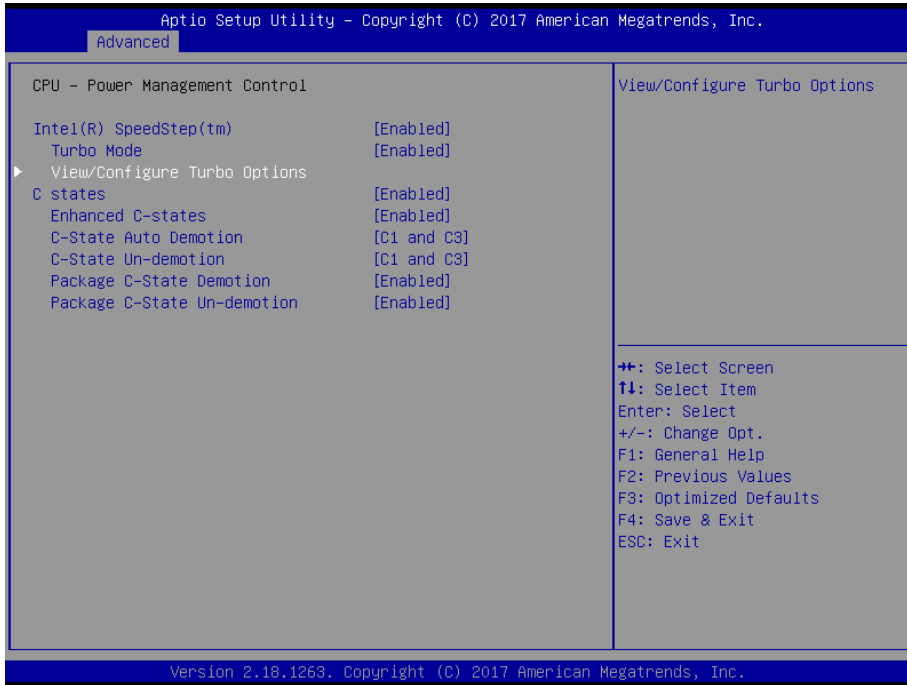

Item	Option	Description
<b>Intel® SpeedStep™</b>	Disabled, Enabled[Default]	Allows more than two frequency ranges to be supported.
<b>Turbo Mode</b>	Disabled, Enabled[Default]	Enable/Disable processor Turbo Mode (requires EMTTM enabled too). AUTO means enabled, unless max turbo ratio is bigger than 16 – SKL A0 W/A.
<b>C states</b>	Disabled, Enabled[Default]	Enable/Disable CPU Power Management. Allows CPU to go to C states when it's not utilized.
<b>Enhanced C-states</b>	Disabled, Enabled[Default]	Enable/Disable C1E. When enabled, CPU will switch to minimum speed when all cores enter C-State.
<b>C-State Auto Demotion</b>	Disabled C1 C3 C1 and C3[Default]	Configure C-State Auto Demotion.
<b>C-State Un-demotion</b>	Disabled C1 C3 C1 and C3[Default]	Configure C-State Un-demotion.
<b>Package C-State Demotion</b>	Disabled, Enabled[Default]	Package C-State Demotion.
<b>Package C-State Un-demotion</b>	Disabled, Enabled[Default]	Package C-State Un-demotion.



### 3.6.2.2 PCH-FW Configuration

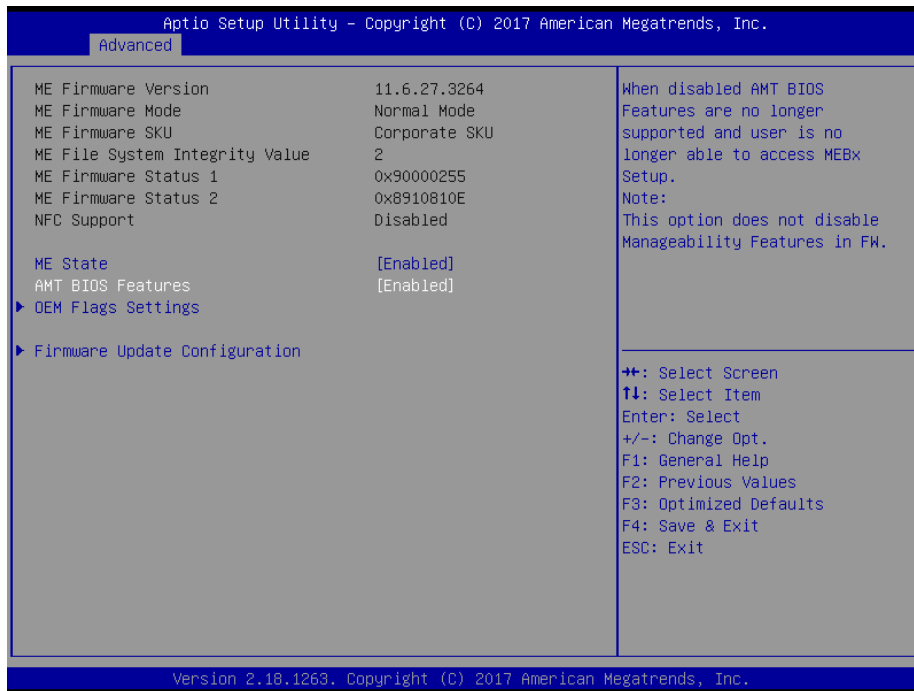

Item	Options	Description
<b>ME State</b>	Disabled, Enabled[Default]	When Disabled ME will be put into ME Temporarily Disabled Mode.
<b>AMT BIOS Features</b>	Disabled, Enabled[Default]	When disabled AMT BIOS Features are no longer supported and user is no longer able to access MEBx Setup. Note: This option does not disable Manageability Features in FW.

#### 3.6.2.2.1 Firmware Update Configuration



## EMX-Q170KP User's Manual

Item	Option	Description
Me FW Image Re-Flash	Disabled[Default], Enabled	Enable/Disable Me FW Image Re-Flash function.

### 3.6.2.2.2 OEM Flags Settings



Item	Option	Description
Unconfigure ME	Disabled[Default], Enabled	OEMFlag Bit 15: Unconfigure ME with resetting MEBx password to default.

### 3.6.2.3 Trusted Computing

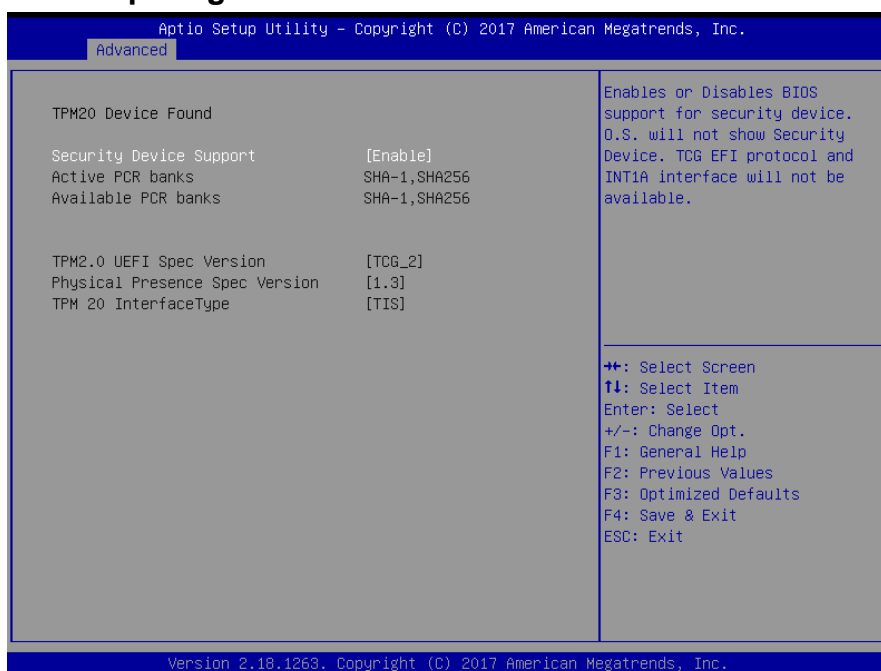

Item	Options	Description
<b>Security Device Support</b>	Disable, Enable[Default]	Enables or Disables BIOS support for security device. O.S. will not show Security Device. TCG EFI protocol and INT1Ainterface will not be available.

### 3.6.2.4 ACPI Settings

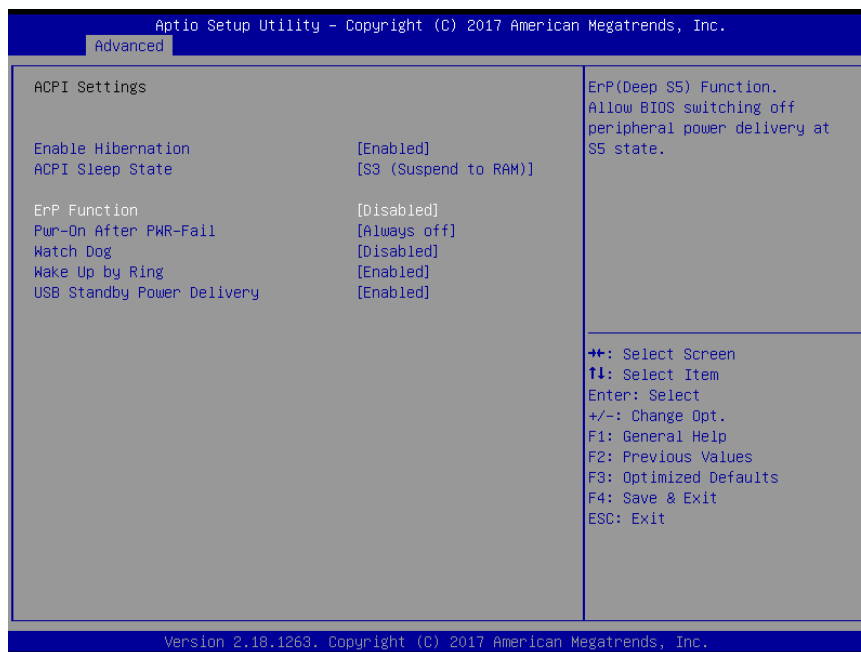

Item	Options	Description
<b>Enable Hibernation</b>	Disabled Enabled[Default],	Enables or Disables System ability to Hibernate (OS/S4 Sleep State). This option may be not effective with some operating systems.
<b>ACPI Sleep State</b>	Suspend Disabled, S3 (Suspend to RAM)[Default]	Select the highest ACPI sleep state the system will enter when the SUSPEDN button is pressed.
<b>ErP Function</b>	Disabled[Default], Enabled	ErP (Deep S5) Function. Allow BIOS switching off peripheral power delivery at S5 state.
<b>Pwr-On After PWR-Fail</b>	Always Off[Default] Always On Keep Last state	Specify what state to go to when power is re-applied after a power failure (G3 state).
<b>Watch Dog</b>	Disabled[Default], 30 sec 40 sec 50 sec 1 min 2 min 10 min 30 min	Select Watch Dog Timer (WDT) Mode.

# EMX-Q170KP User's Manual

<b>Wake Up by Ring</b>	Disabled Enabled[Default],	Enable/Disable system waked up by Ring signal from S3(Sleep). S4(Hibernate) and S5(Soft Off) States.
<b>USB Standby Power Delivery</b>	Disabled Enabled[Default],	Enable/Disable USB Power delivery in S3 (Sleep), S4 (Hibernate) and S5 (Soft Off) States.

## 3.6.2.5 S5 RTC Wake Settings

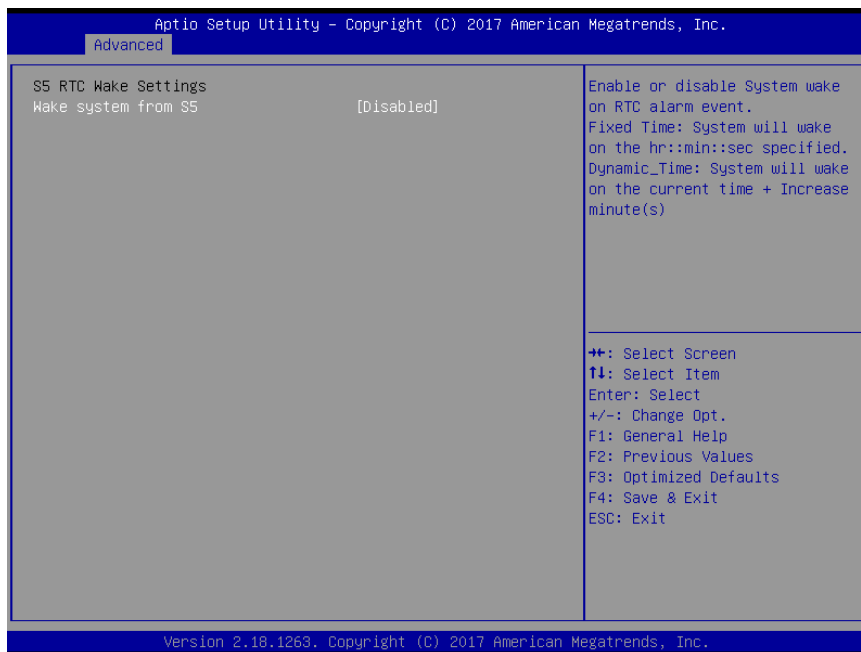

Item	Options	Description
<b>Wake system from S5</b>	Disabled[Default], Fixed Time Dynamic Time	Enable or disable System wake on alarm event. Select Fixed Time, system will wake on the hr::min::sec specified. Select Dynamic Time, System will wake on the current time + Increase minute(s).

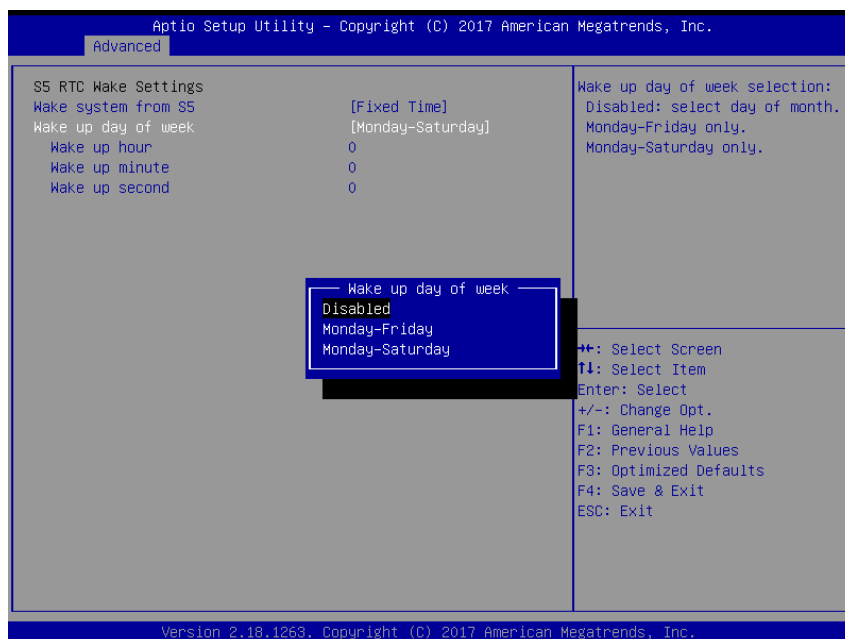

Item	Options	Description
<b>Wake system from S5</b>	Disabled, Fixed Time[Default] Dynamic Time	Enable or disable System wake on alarm event. Select Fixed Time, system will wake on the hr::min::sec specified. Select Dynamic Time, System will wake on the current time + Increase minute(s).
<b>Wake up day of week</b>	Disabled[Default], Monday-Friday Monday-Saturday	Wake up day of week selection: Disabled: select day of month. Monday-Friday only. Monday-Saturday only.
<b>Wake up hour</b>	0-23	Select 0-23 For example enter 3 for 3am and 15 for 3pm.
<b>Wake up minute</b>	0-59	0-59.
<b>Wake up second</b>	0-59	0-59.

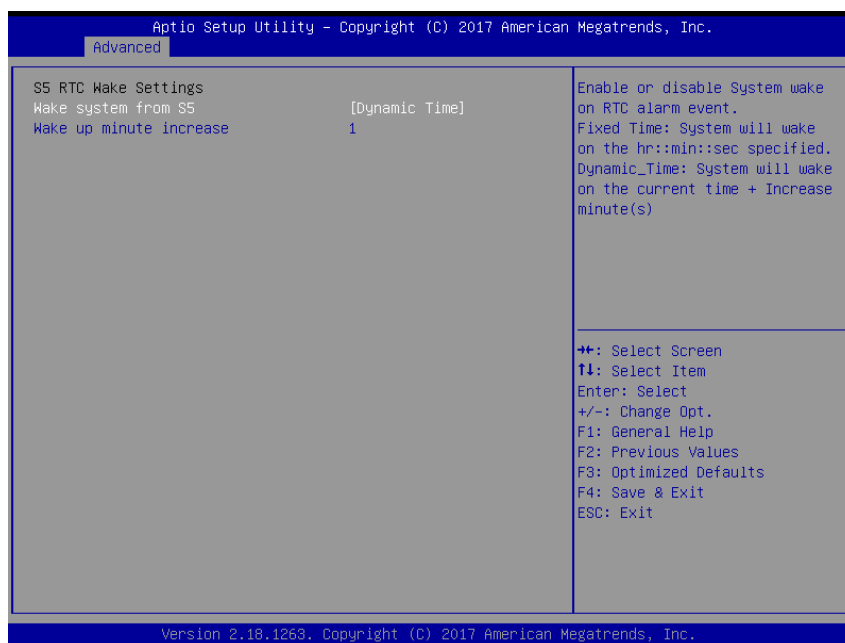

Item	Options	Description
<b>Wake system from S5</b>	Disabled, Fixed Time Dynamic Time[Default]	Enable or disable System wake on alarm event. Select Fixed Time, system will wake on the hr::min::sec specified. Select Dynamic Time, System will wake on the current time + Increase minute(s).
<b>Wake up minute increase</b>	1-5	1-5.

# EMX-Q170KP User's Manual

## 3.6.2.6 Super IO Configuration

You can use this item to set up or change the Super IO configuration for serial ports. Please refer to 3.6.2.6.1~ 3.6.2.6.6 for more information.

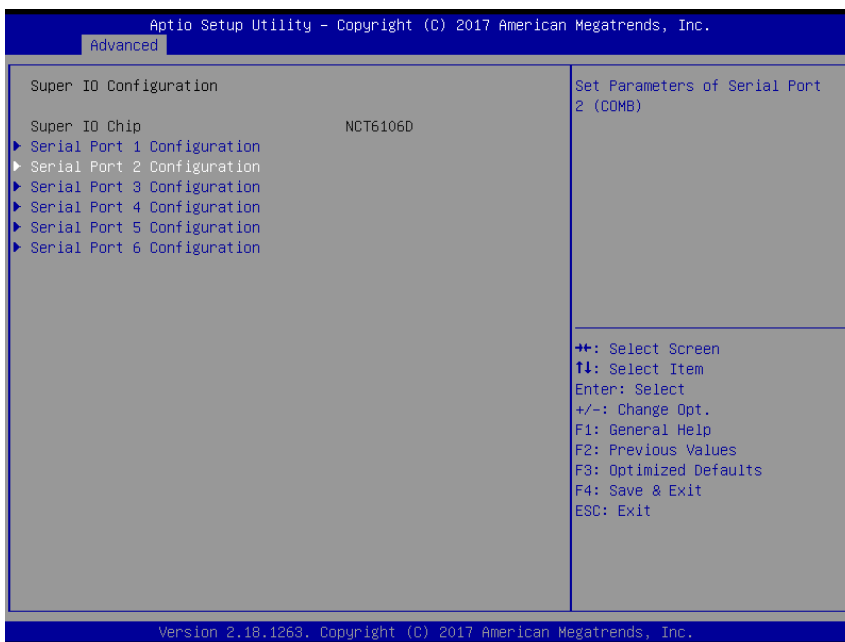

Item	Description
<b>Serial Port 1 Configuration</b>	Set Parameters of Serial Port 1 (COMA).
<b>Serial Port 2 Configuration</b>	Set Parameters of Serial Port 2 (COMB).
<b>Serial Port 3 Configuration</b>	Set Parameters of Serial Port 3 (COMC).
<b>Serial Port 4 Configuration</b>	Set Parameters of Serial Port 4 (COMD).
<b>Serial Port 5 Configuration</b>	Set Parameters of Serial Port 5 (COME).
<b>Serial Port 6 Configuration</b>	Set Parameters of Serial Port 6 (COMF).

### 3.6.2.6.1 Serial Port 1 Configuration

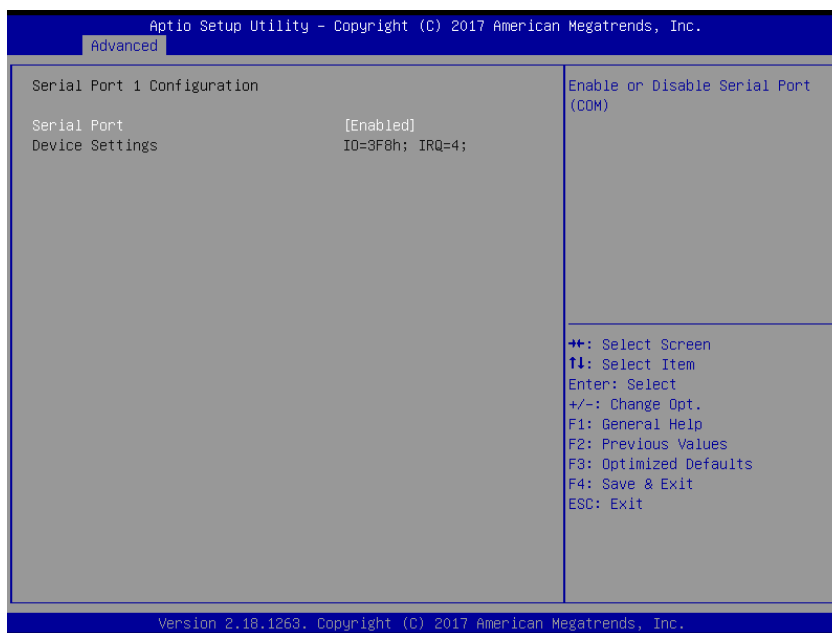

Item	Option	Description
Serial Port	Enabled[Default], Disabled	Enable or Disable Serial Port (COM).

### 3.6.2.6.2 Serial Port 2 Configuration

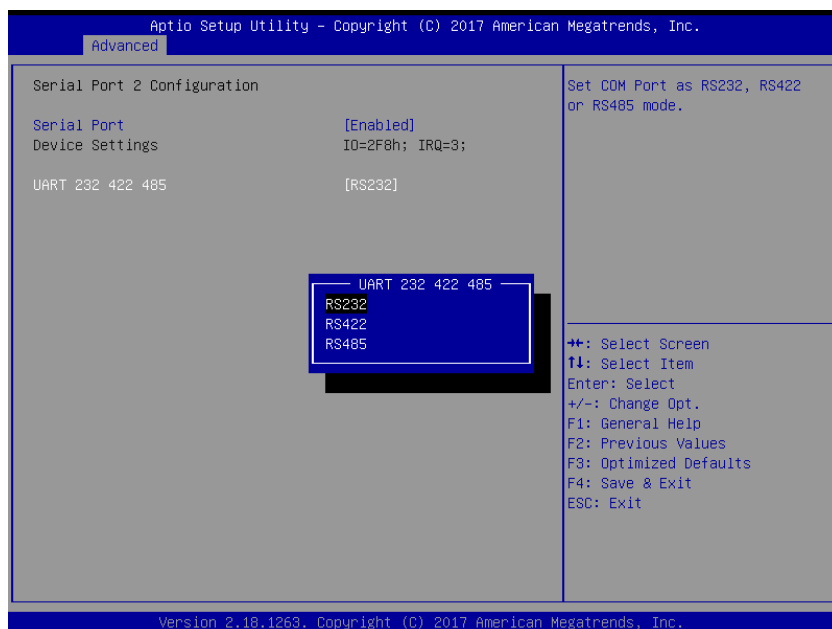

Item	Option	Description
Serial Port	Enabled[Default], Disabled	Enable or Disable Serial Port (COM).
UART 232 422 485	RS232[Default] RS422 RS485	Set COM Port as RS232, RS422 or RS485 mode.

3.6.2.6.3 Serial Port 3 Configuration

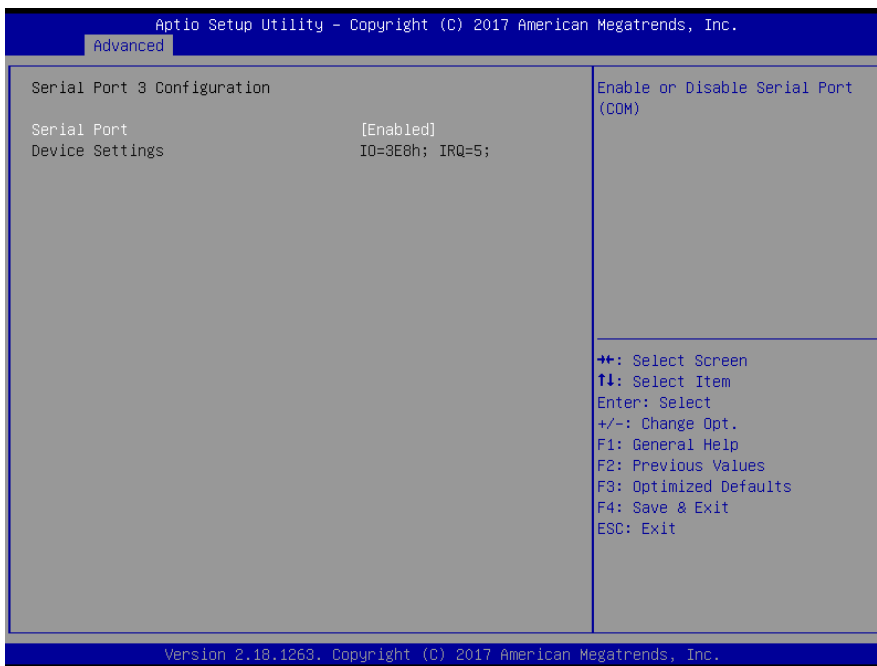

Item	Option	Description
Serial Port	Enabled[Default], Disabled	Enable or Disable Serial Port (COM).

3.6.2.6.4 Serial Port 4 Configuration

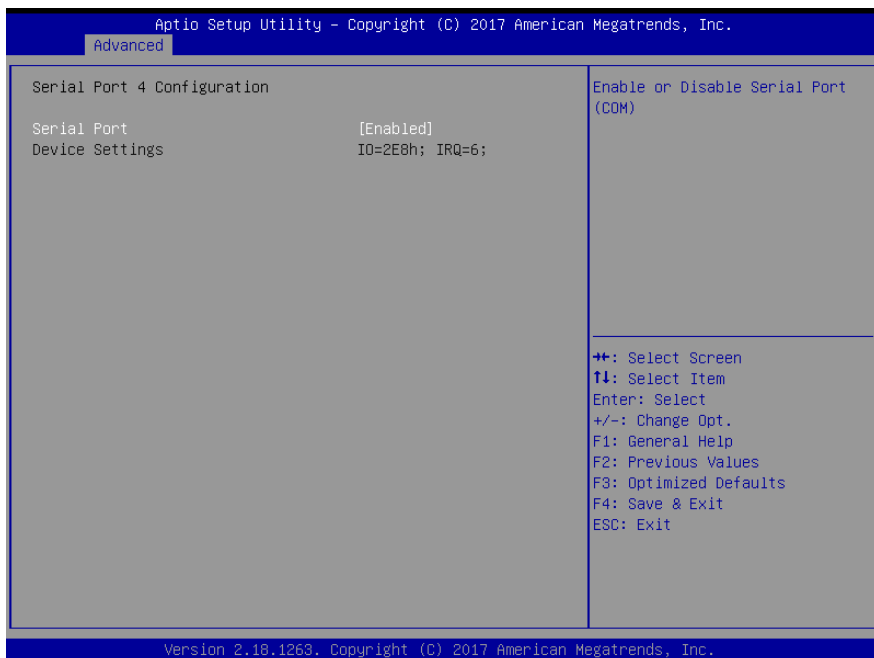

Item	Option	Description
Serial Port	Enabled[Default], Disabled	Enable or Disable Serial Port (COM).



### 3.6.2.6.5 Serial Port 5 Configuration

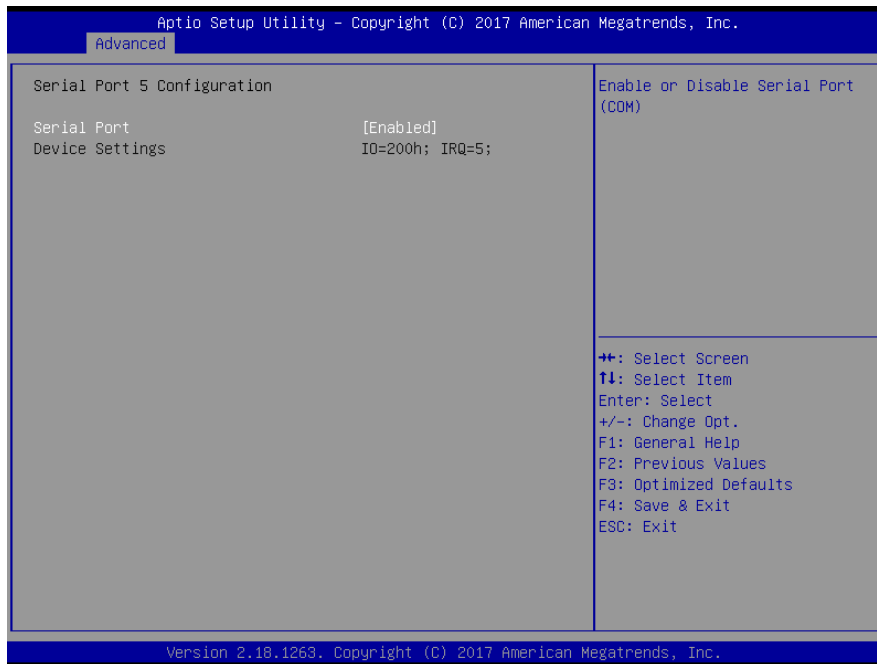

Item	Option	Description
Serial Port	Enabled[Default], Disabled	Enable or Disable Serial Port (COM).

### 3.6.2.6.6 Serial Port 6 Configuration

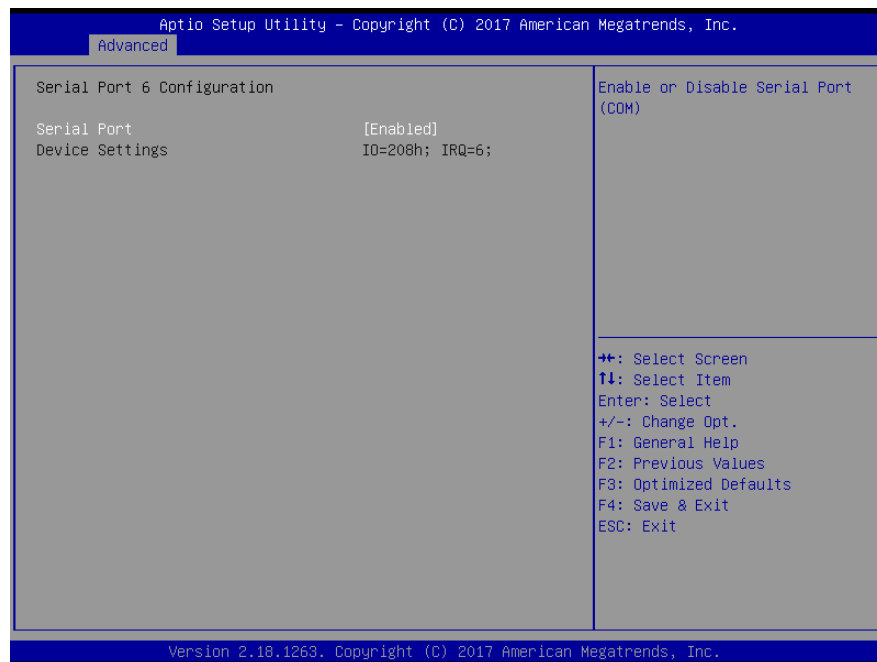

Item	Option	Description
Serial Port	Enabled[Default], Disabled	Enable or Disable Serial Port (COM).

# EMX-Q170KP User's Manual

## 3.6.2.7 NCT6106D H/W Monitor

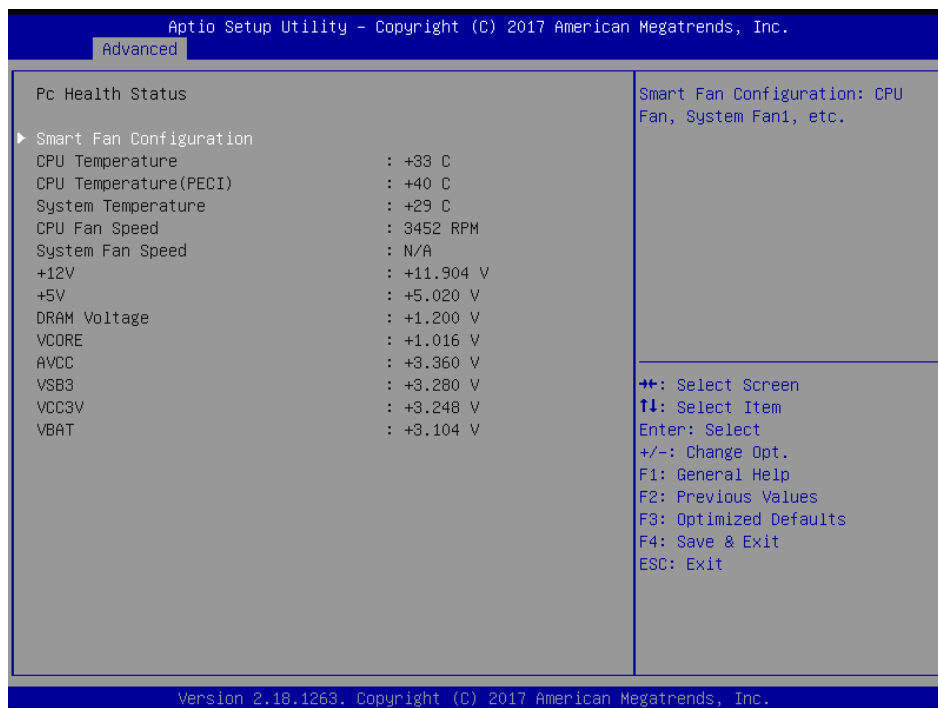

### 3.6.2.7.1 Smart Fan Configuration

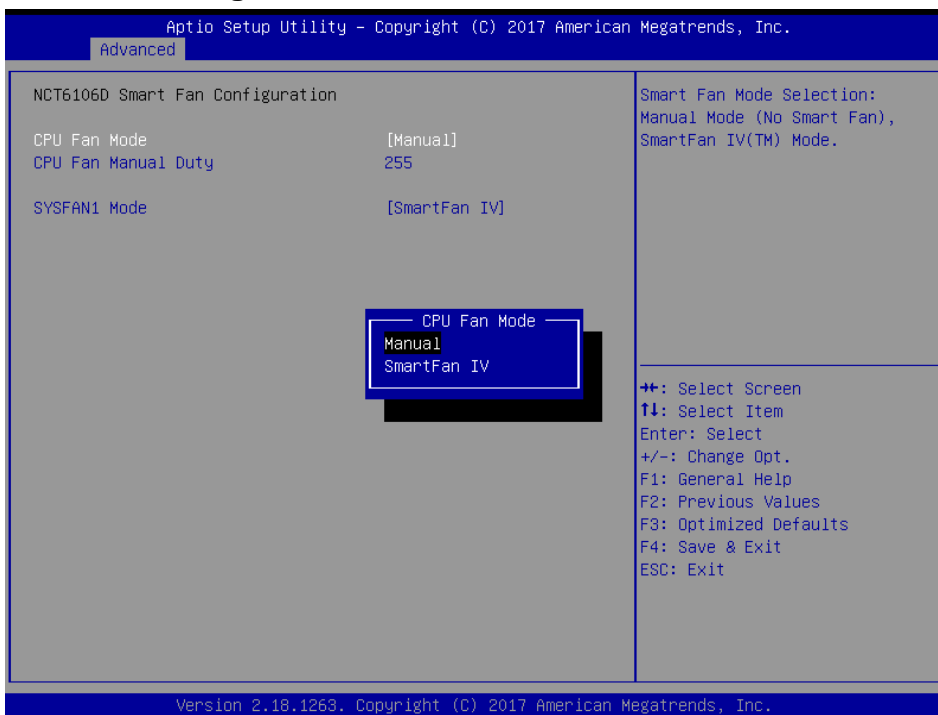

Item	Option	Description
CPU Fan Mode	Manual[Default], SmartFan IV	Smart Fan Mode Selection: Manual Mode (No Smart Fan), SmartFan IV™ Mode.
CPU Fan Manual Duty	0-255	CPU Fan manual output duty: 0 to 255.
SYSFAN1 Mode	Manual SmartFan IV[Default],	Smart Fan Mode Selection: Manual Mode (No Smart Fan), SmartFan IV™ Mode.

### 3.6.2.8 Serial Port Console Redirection

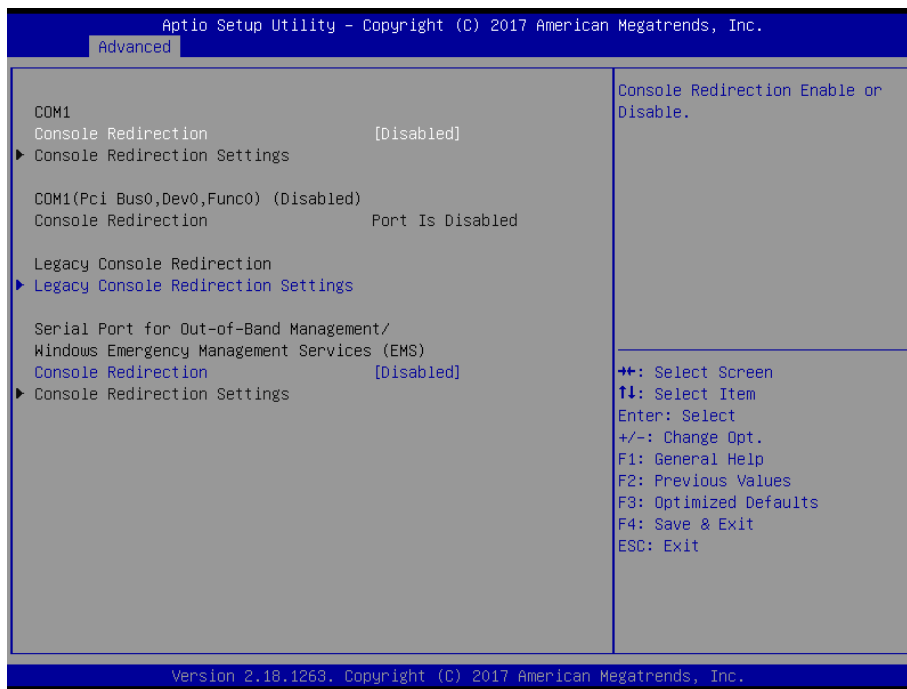

Item	Options	Description
Console Redirection	Disabled[Default], Enabled	Console Redirection Enable or Disable.

#### 3.6.2.8.1 COM1

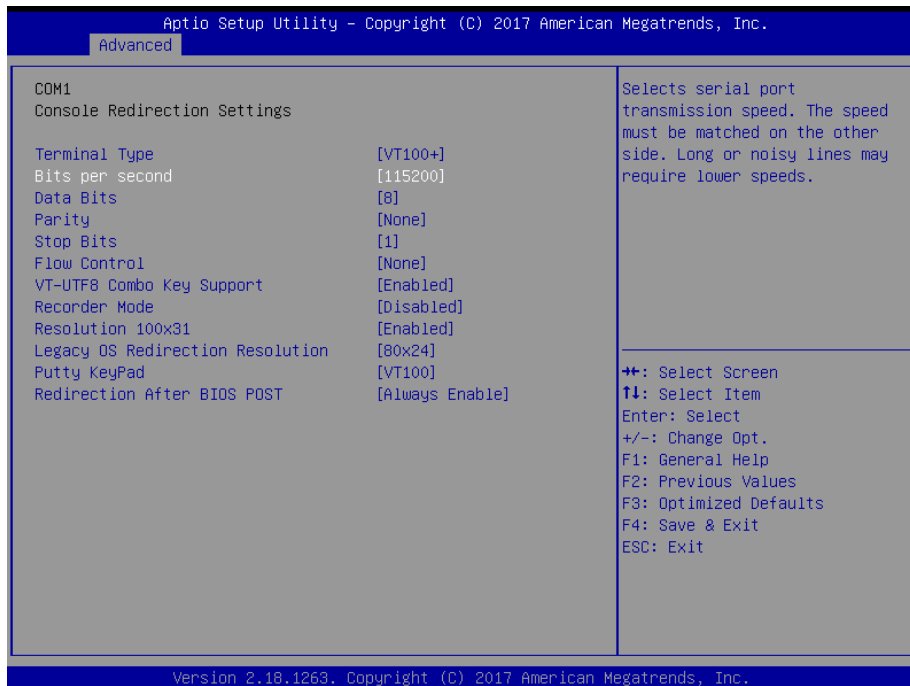

## EMX-Q170KP User's Manual

Item	Option	Description
<b>Terminal Type</b>	VT100 VT100+ <b>[Default]</b> VT-UTF8 ANSI	Emulation: ANSI: Extended ASCII char set. VT100: ASCII char set. VT100+: Extends VT100 to support color, function keys, etc. VT-UTF8: Uses UTF8 encoding to map Unicode chars onto 1 or more bytes.
<b>Bits per second</b>	9600 19200 38400 57600 115200 <b>[Default]</b>	Select serial port transmission speed. The speed must be matched on the other side. Long or noisy lines may require lower speeds.
<b>Data Bits</b>	7 8 <b>[Default]</b>	Data Bits.
<b>Parity</b>	None <b>[Default]</b> Even Odd Mark Space	A parity bit can be sent with the data bits to detect some transmission errors. Even: parity bit is 0 if the num of 1's in the data bits is even. Odd: parity bit is 0 if num of 1's in the data bits is odd. Mark: Parity bit is always. 1. Space: Parity bit is always 0. Mark and Space Parity do not allow for error detection. They can be used as an additional data bit.
<b>Stop Bits</b>	1 <b>[Default]</b> 2	Stop bits indicate the end of a serial data packet. (A start bit indicates the beginning). The standard setting is 1 stop bit. Communication with slow devices may require more than 1 stop bit.
<b>Flow Control</b>	None <b>[Default]</b> Hardware RTS/CTS	Flow control can prevent data loss from buffer overflow. When sending data, if the receiving buffers are full, a 'stop' signal can be sent to stop the data flow. Once the buffers are empty, a 'start' signal can be sent to re-start the flow. Hardware flow control uses two wires to send start/stop signals.
<b>VT-UTF8 Combo Key Support</b>	Disabled Enabled <b>[Default]</b>	Enable VT-UTF8 Combination Key Support for ANSI/VT100 terminals.
<b>Recorder Mode</b>	Disabled <b>[Default]</b> Enabled	With this mode enabled only text will be sent. This is to capture Terminal data.
<b>Resolution 100x31</b>	Disabled Enabled <b>[Default]</b>	Enables or disables extended terminal resolution.
<b>Legacy OS Redirection Resolution</b>	80x24 <b>[Default]</b> 80x25	On Legacy OS, the Number of Rows and Columns supported redirection.
<b>Putty KeyPad</b>	VT100 <b>[Default]</b> LINUX XTERMR6 SCO ESCN VT400	Select FunctionKey and KeyPad on Putty.
<b>Redirection After BIOS POST</b>	Always Enable <b>[Default]</b> BootLoader	The Settings specify if BootLoader is selected then Legacy console redirection is disabled before booting to Legacy OS.

		Default value is Always Enabled which means Legacy console Redirection is enabled.
--	--	--

### 3.6.2.9 Intel TXT Configuration

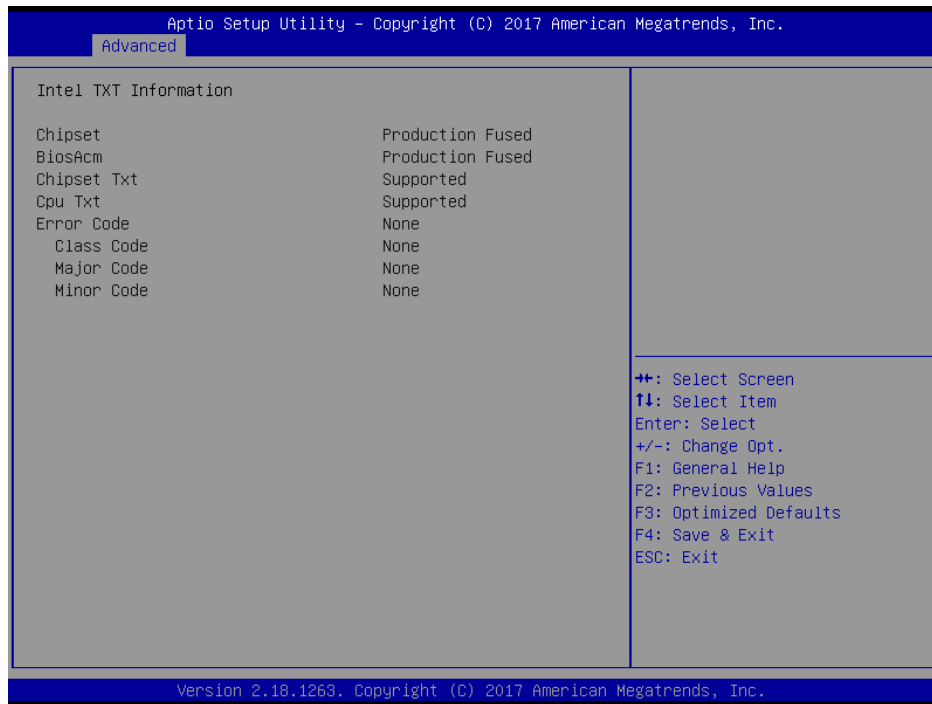

### 3.6.2.10 Network Stack Configuration

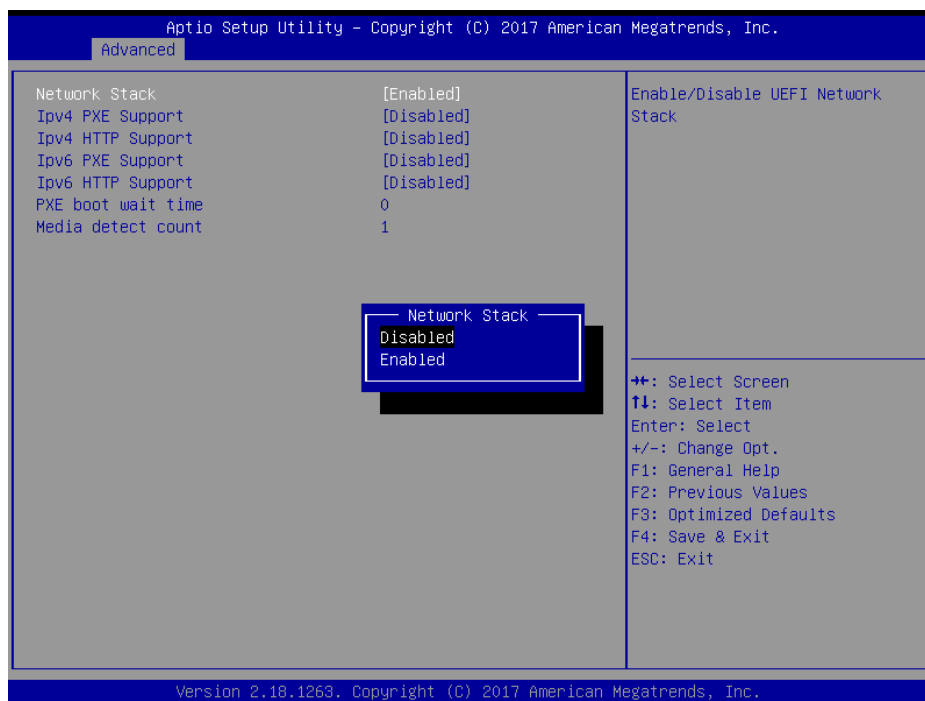

Item	Options	Description
Network Stack	Enabled[Default] Disabled	Enable/Disable UEFI Network Stack.

## EMX-Q170KP User's Manual

<b>Ipv4 PXE Support</b>	Enabled Disabled[ <b>Default</b> ]	Enable Ipv4 PXE Boot Support. If disabled IPV4 PXE boot option will not be created.
<b>Ipv4 HTTP Support</b>	Enabled Disabled[ <b>Default</b> ]	Enable Ipv4 HTTP Boot Support. If disabled IPV4 HTTP boot option will not be created.
<b>Ipv6 PXE Support</b>	Enabled Disabled[ <b>Default</b> ]	Enable Ipv6 PXE Boot Support. If disabled IPV4 PXE boot option will not be created.
<b>Ipv6 HTTP Support</b>	Enabled Disabled[ <b>Default</b> ]	Enable Ipv6 HTTP Boot Support. If disabled IPV4 HTTP boot option will not be created.
<b>PXE boot wait time</b>	0	Wait time to press ESC key to abort the PXE boot.
<b>Media detect count</b>	1	Number of times presence of media will be checked.

### 3.6.2.11 CSM Configuration

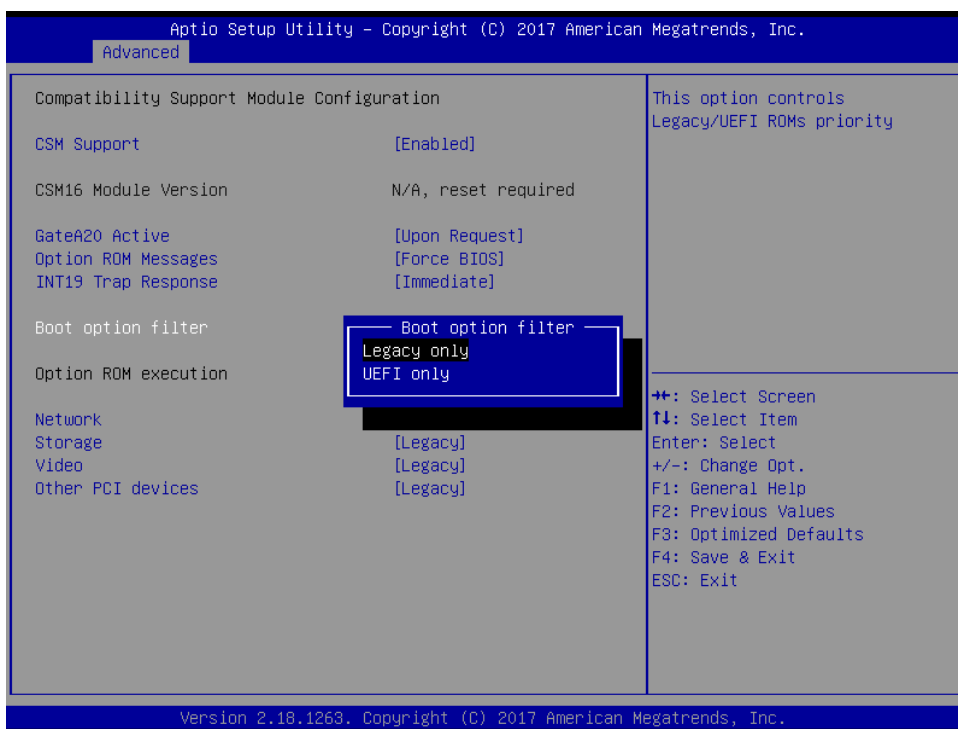
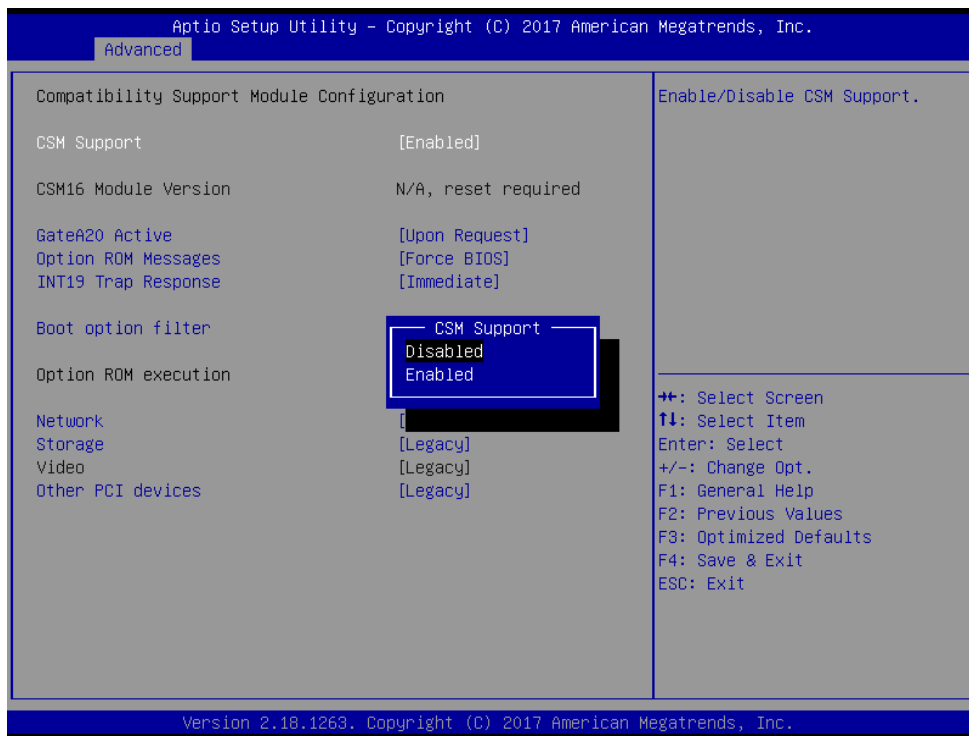

Item	Options	Description
<b>CSM Support</b>	Enabled[Default] Disabled	Enable/Disable CSM Support.
<b>GateA20 Active</b>	Upon Request[Default] Always	UPON REQUEST – GA20 can be disabled using BIOS services. ALWAYS – do not

## EMX-Q170KP User's Manual

		allow disabling GA20; this option is useful when any RT code is executed above 1MB.
<b>Option ROM Messages</b>	Force BIOS[Default] Keep Current	Set display mode for Option ROM.
<b>INT19 Trap Response</b>	Immediate[Default] Postponed	BIOS reaction on INT19 trapping by Option ROM: IMMEDIATE – execute the trap right away; POSTPONED – execute the trap during legacy boot.
<b>Boot option filter</b>	Legacy only[Default] UEFI only	This option controls Legacy/UEFI ROMs priority.
<b>Network</b>	Do not launch[Default] UEFI Legacy	Controls the execution of UEFI and Legacy PXE OpROM.
<b>Storage</b>	Do not launch UEFI Legacy[Default]	Controls the execution of UEFI and Legacy Storage OpROM.
<b>Other PCI devices</b>	Do not launch UEFI Legacy[Default]	Determines OpROM execution policy for devices other than Network, Storage, or Video.

### 3.6.2.12 USB Configuration

The USB Configuration menu helps read USB information and configures USB settings.

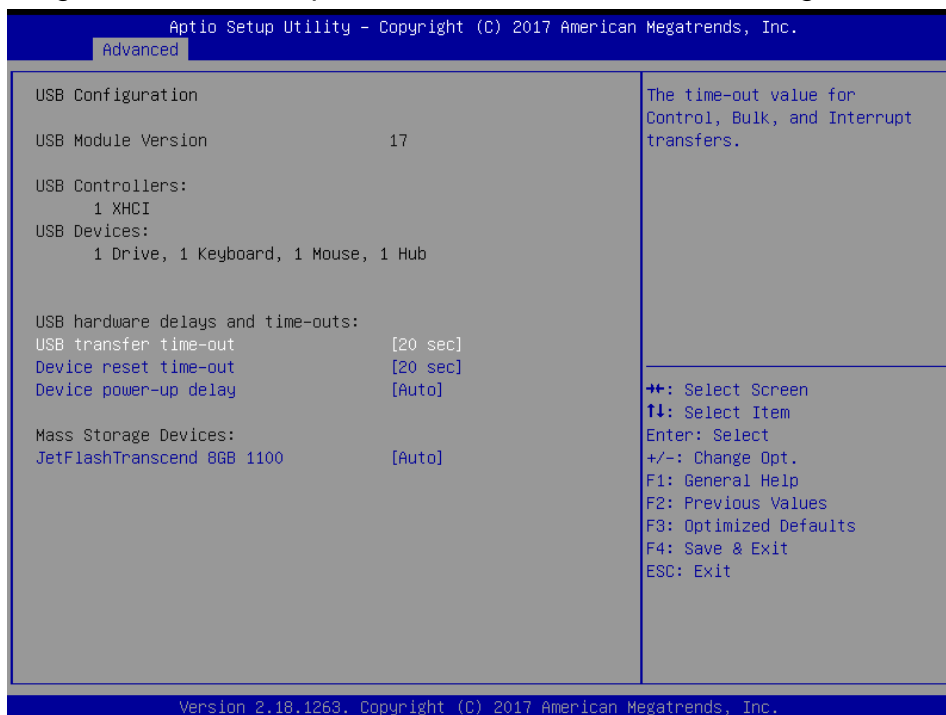

Item	Options	Description
<b>USB transfer time-out</b>	1 sec 5 sec 10 sec 20 sec[Default]	The time-out value for Control, Bulk, and Interrupt transfers.
<b>Device reset time-out</b>	10 sec 20 sec[Default]	USB mass storage device Start Unit command time-out.



	30 sec 40 sec	
<b>Device power-up delay</b>	Auto[Default] Manual	Maximum time the device will take before it properly reports itself to the Host Controller. 'Auto' uses default value: for a Root port it is 100ms, for a Hub port the delay is taken from Hub descriptor.
<b>Mass Storage Devices</b>	Auto[Default] Floppy Forced FDD Hard Disk CD-ROM	Mass storage device emulation type. 'AUTO' enumerates devices according to their media format. Optical drives are emulated as 'CDROM', drives with no media will be emulated according to a drive type.

### 3.6.3 Chipset

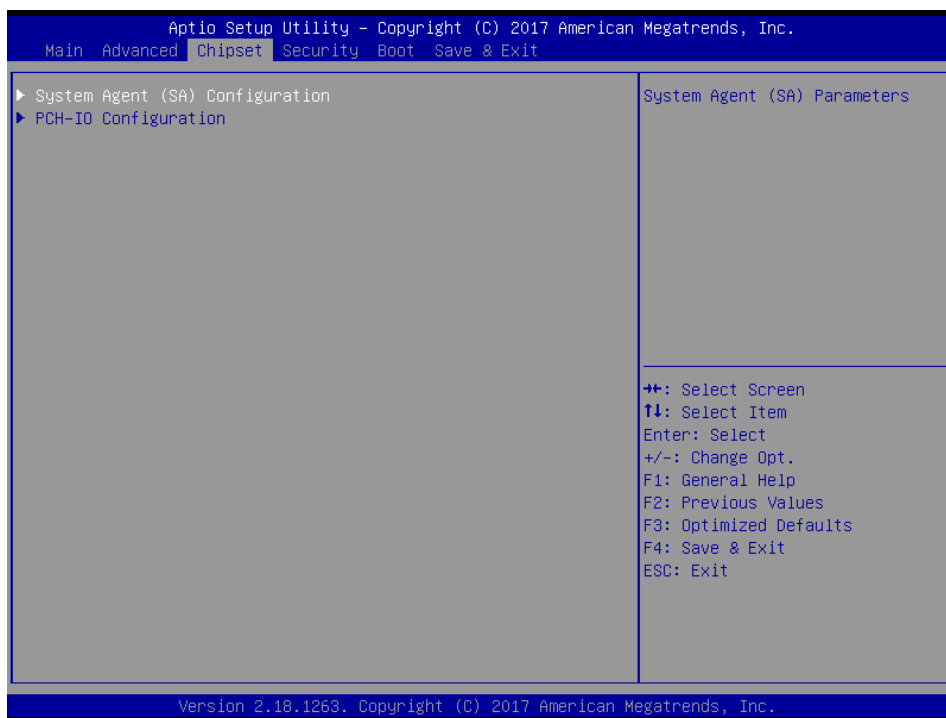

### 3.6.3.1 System Agent (SA) Configuration

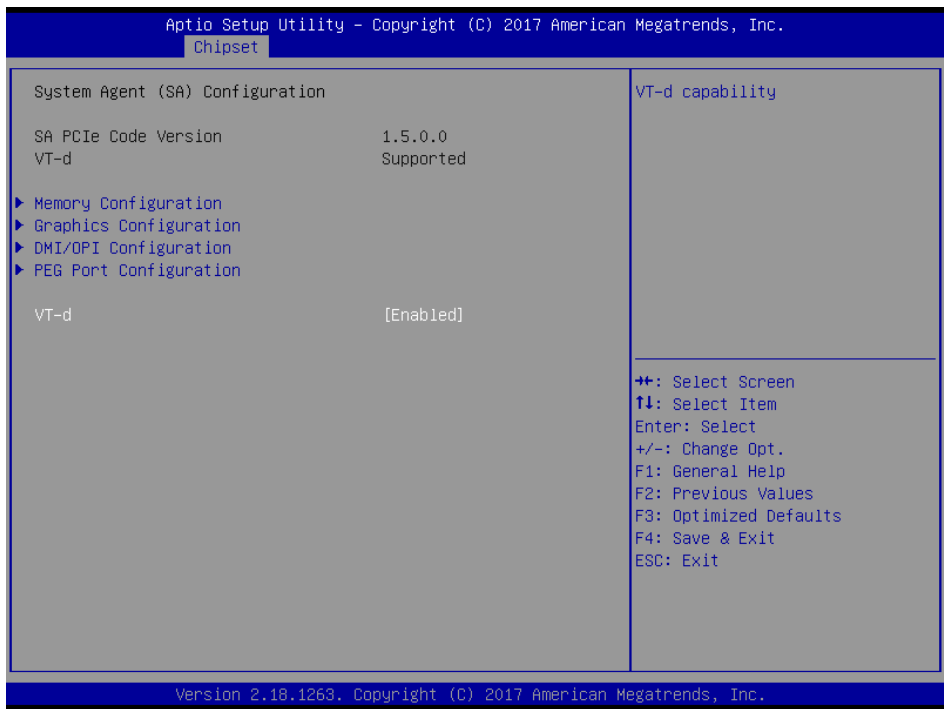

Item	Option	Description
VT-d	Enabled[Default] Disabled	VT-d capability.

#### 3.6.3.1.1 Graphics Configuration

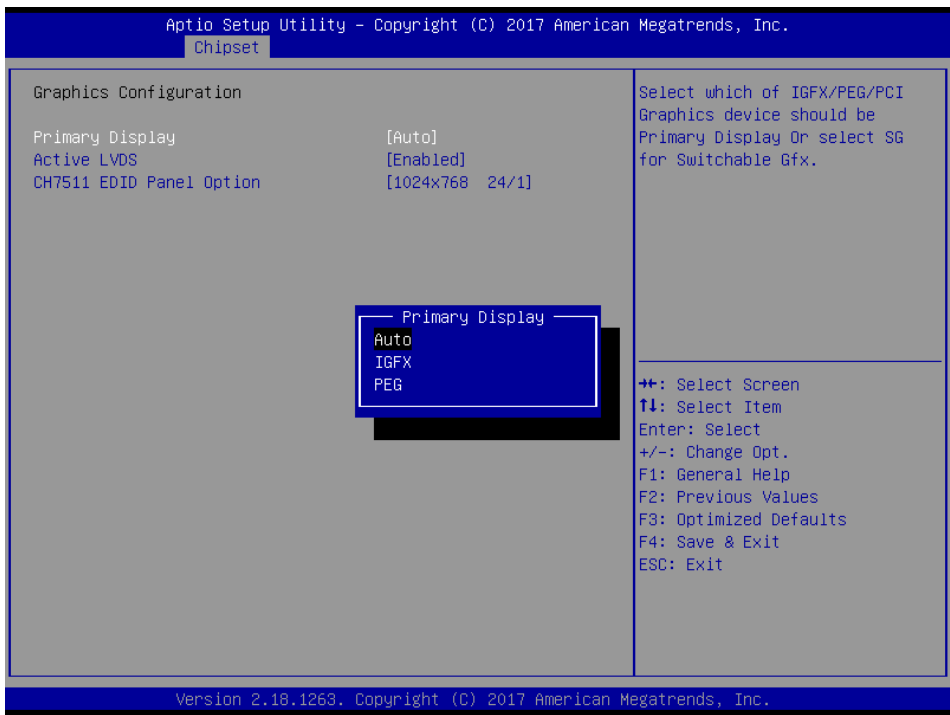

Item	Option	Description
Primary Display	Auto[Default] IGFX PEG	Select which of IGFX/PEG/PCI Graphics device should be Primary Display Or select SG for Switchable Gfx.
Active LVDS	Disabled Enabled[Default]	Active on-board eDP to LVDS Converter.
CH7511 EDID Panel Option	1024x768 24/1 [Default] 800x600 18/1 1024x768 18/1 1366x768 18/1 1024x600 18/1 1280x800 18/1 1920x1200 24/2 1920x1080 18/2 1280x1024 24/2 1440x900 18/2 1600x1200 24/2 1366x768 24/1 1920x1080 24/2 1680x1050 24/2	Set which panel resolution EDID reported by CH7511.

### 3.6.3.1.2 DMI/OPI Configuration



3.6.3.1.3 PEG Port Configuration

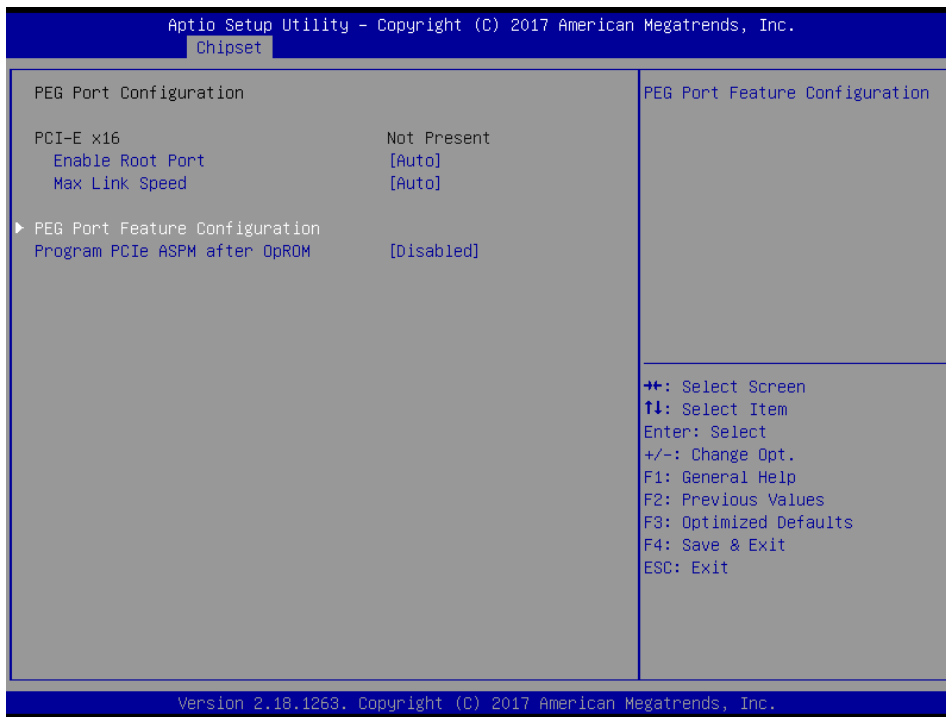

Item	Option	Description
<b>Enable Root Port</b>	Disabled Enabled Auto[Default]	Enable or Disable the Root Port.
<b>Max Link Speed</b>	Auto[Default] Gen1 Gen2 Gen3	Configure PEG 0:1:0 Max Speed.
<b>Program PCIe ASPM after OpROM</b>	Disabled[Default] Enabled	Enabled: PCIe ASPM will be programmed after OpROM. Disabled: PCIe ASPM will be programmed before OpROM.

### 3.6.3.1.3.1 PEG Port Feature Configuration

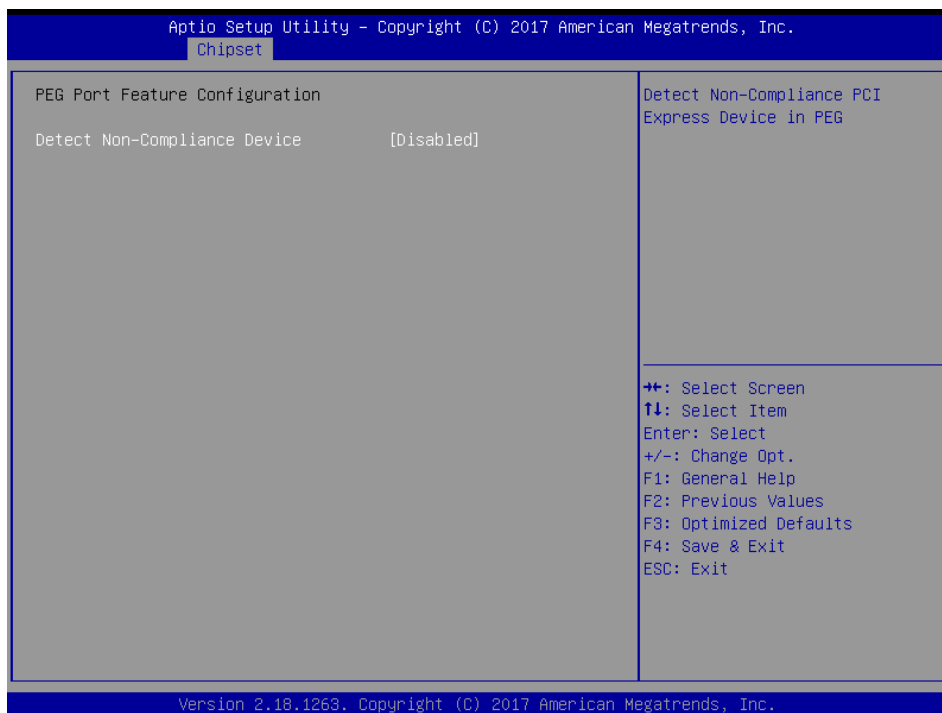

Item	Option	Description
Detect Non-Compliance Device	Enabled, Disabled[Default]	Detect Non-Compliance PCI Express Device in PEG.

### 3.6.3.1.4 Memory Configuration

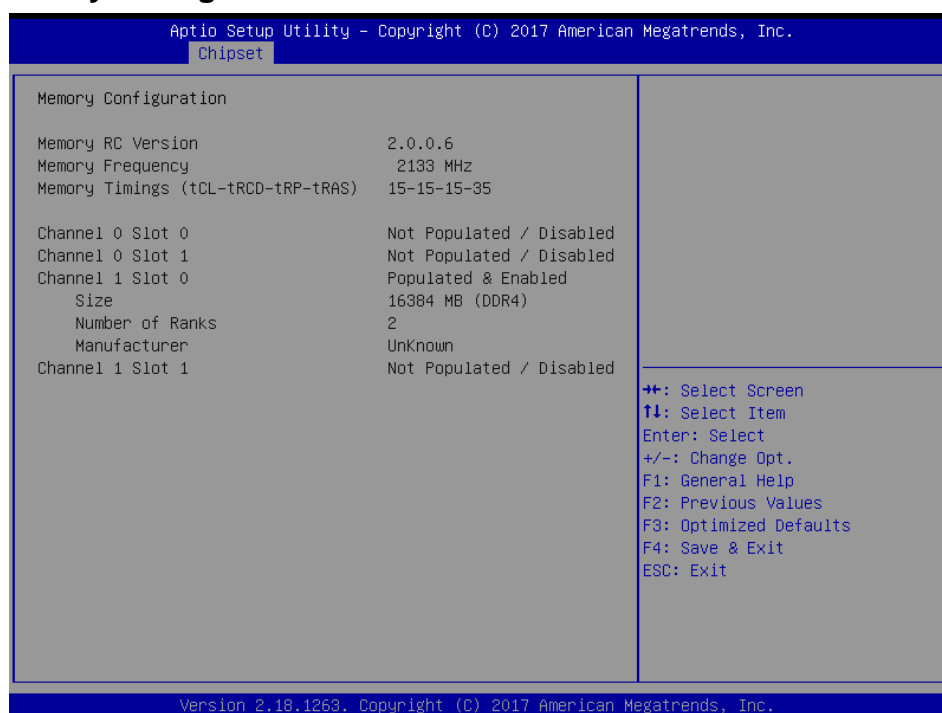

3.6.3.2 PCH-IO Configuration

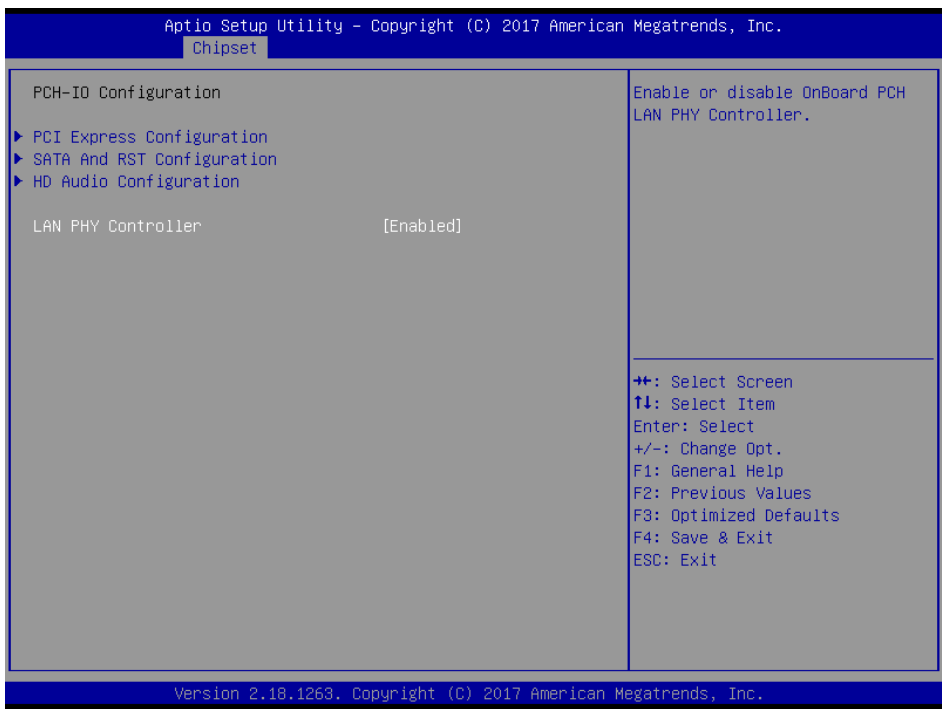

Item	Option	Description
LAN PHY Controller	Disabled	Enable or disable OnBoard PCH LAN PHY Controller.
	Enabled[Default]	

3.6.3.2.1 PCI Express Configuration

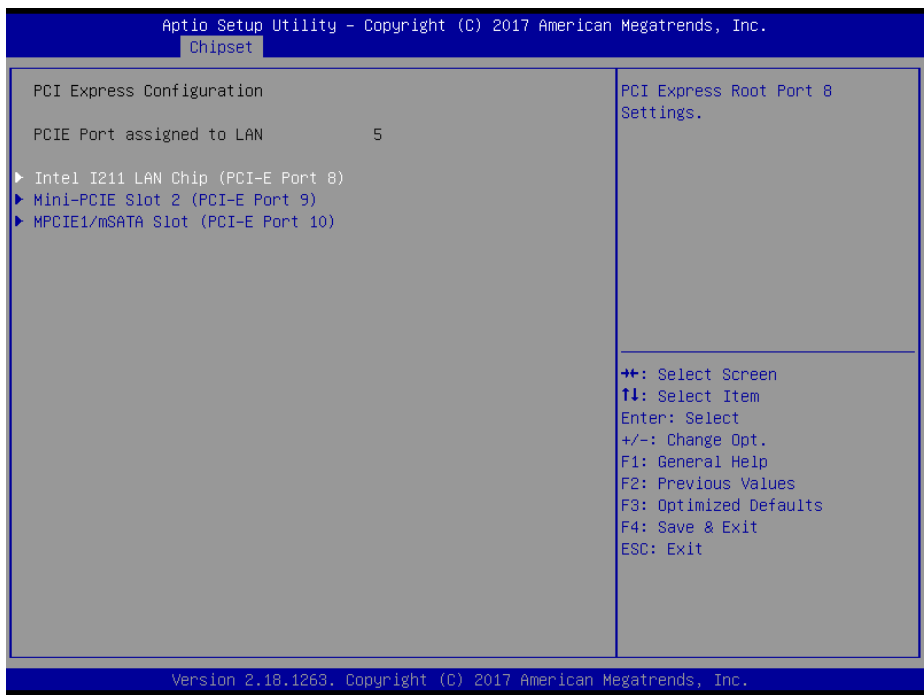

### 3.6.3.2.1.1 Intel I211 LAN Chip (PCI-E Port 8)

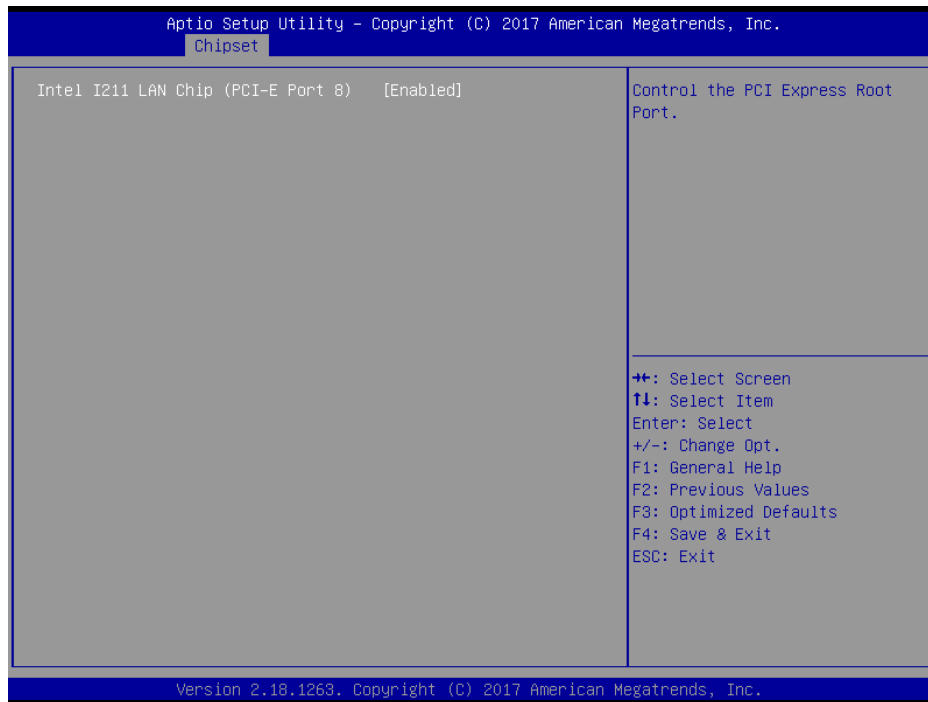

Item	Option	Description
Intel I211 LAN Chip (PCI-E Port 8)	Enabled[Default], Disabled	Control the PCI Express Root Port.

### 3.6.3.2.1.2 Mini-PCIE Slot 2 (PCI-E Port 9)

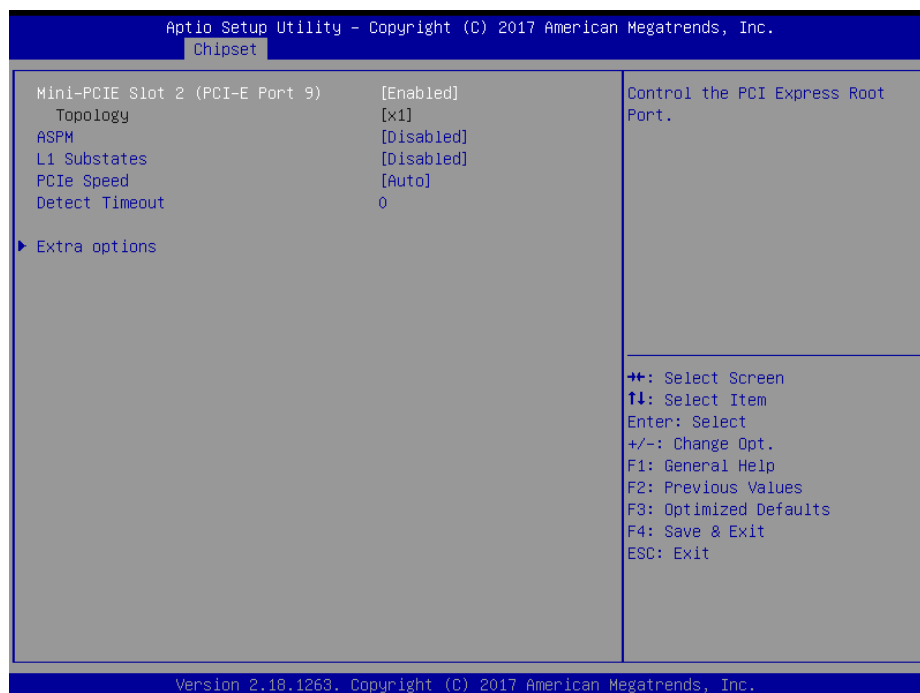

## EMX-Q170KP User's Manual

Item	Option	Description
Mini-PCIE Slot 2 (PCI-E Port 9)	Enabled[Default], Disabled	Control the PCI Express Root Port.
ASPM	Auto L0sL1 L1 L0s Disabled[Default]	Set the ASPM Level: Force L0s – Force all links to L0s State AUTO – BIOS auto configure DISABLE – Disables ASPM.
L1 Substates	Disabled[Default] L1.1 L1.2 L1.1 & L1.2	PCI Express L1 Substates settings.
PCIe Speed	Auto[Default] Gen1 Gen2	Configure PCIe Speed.
Detect Timeout	0	The number of milliseconds reference code will wait for link to exit Detect state for enabled ports before assuming there is no device and potentially disabling the port.

### 3.6.3.2.1.3 MPCIE1/mSATA Slot (PCI-E Port 10)

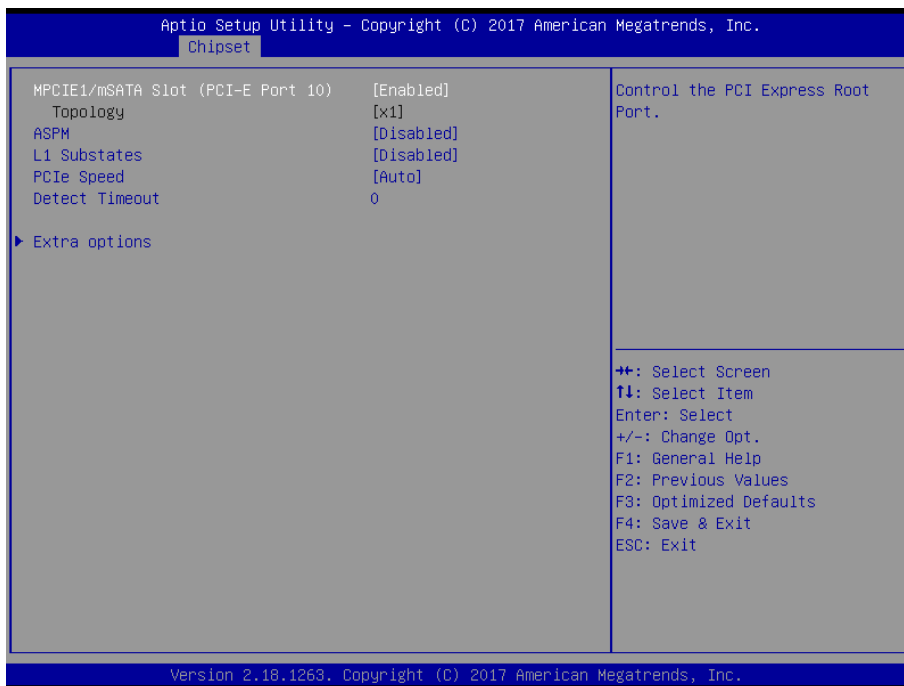

Item	Option	Description
MPCIE1/mSATA Slot (PCI-E Port 10)	Enabled[Default], Disabled	Control the PCI Express Root Port.
ASPM	Auto L0sL1 L1 L0s	Set the ASPM Level: Force L0s – Force all links to L0s State AUTO – BIOS auto configure DISABLE – Disables ASPM.



	Disabled[Default]	
<b>L1 Substates</b>	Disabled[Default] L1.1 L1.2 L1.1 & L1.2	PCI Express L1 Substates settings.
<b>PCIe Speed</b>	Auto[Default] Gen1 Gen2	Configure PCIe Speed.
<b>Detect Timeout</b>	0	The number of milliseconds reference code will wait for link to exit Detect state for enabled ports before assuming there is no device and potentially disabling the port.

3.6.3.2.2 SATA And RST Configuration

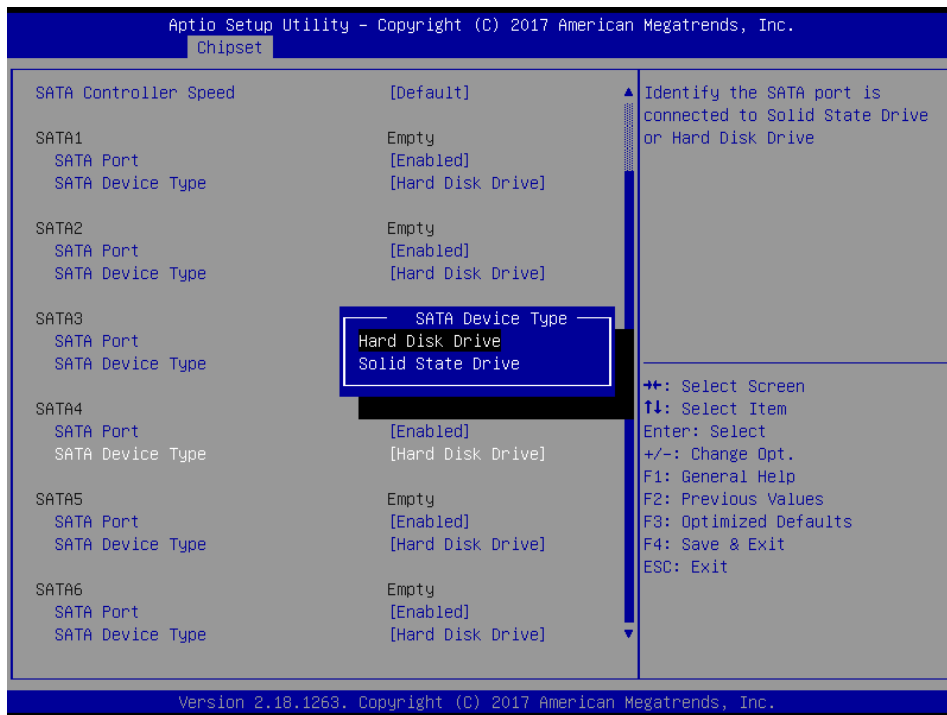
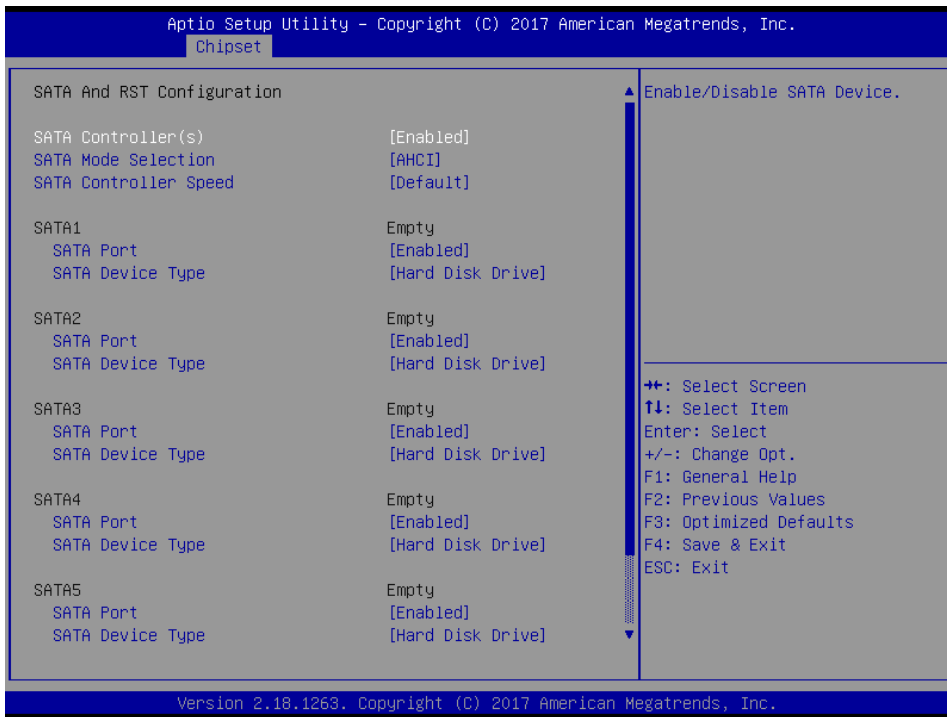

Item	Option	Description
SATA Controller(s)	Enabled[Default], Disabled	Enable/Disable SATA Device.
SATA Mode Selection	AHCI[Default], RAID	Determines how SATA controller(s) operate.
SATA Controller Speed	Default[Default], Gen1 Gen2	Indicates the maximum speed the SATA controller can support.

	Gen3	
<b>SATA Port</b>	Enabled[ <b>Default</b> ], Disabled	Enable or Disable SATA Port.
<b>SATA Device Type</b>	Hard Disk Drive[ <b>Default</b> ] Solid State Drive	Identify the SATA port is connected to Solid State Drive or Hard Disk Drive.

### 3.6.3.2.3 HD Audio Configuration

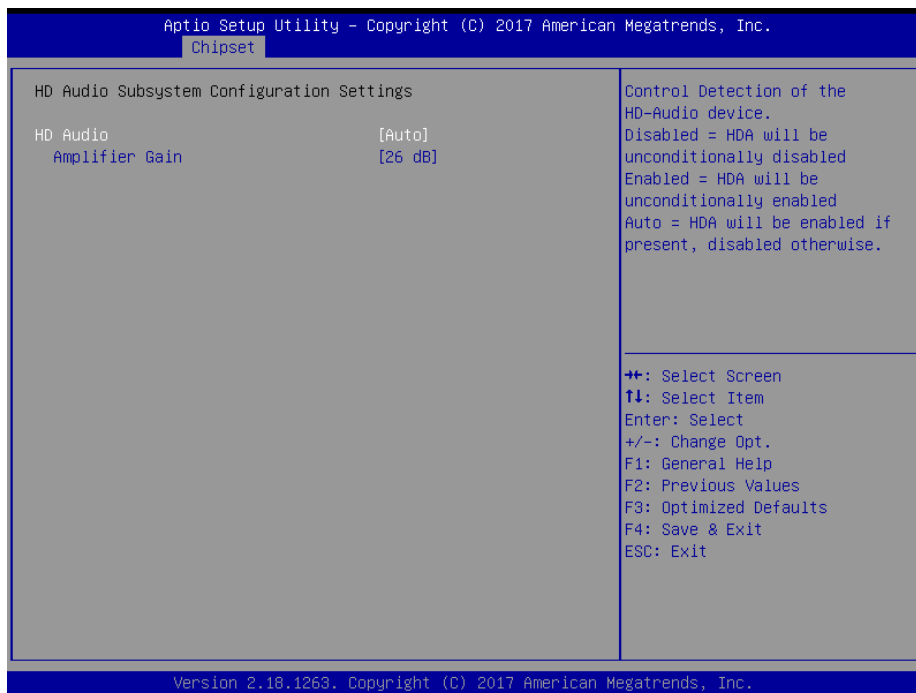

Item	Option	Description
<b>HD Audio</b>	Disabled Enabled, Auto[ <b>Default</b> ]	Control Detection of the HD-Audio device. Disabled = HAD will be unconditionally disabled Enabled = HAD will be unconditionally enabled Auto = HAD will be enabled if present, disabled otherwise.
<b>Amplifier Gain</b>	20 dB 26 dB[ <b>Default</b> ], 32 dB 36 dB	Select Amplifier Gain(dB).

## 3.6.4 Security

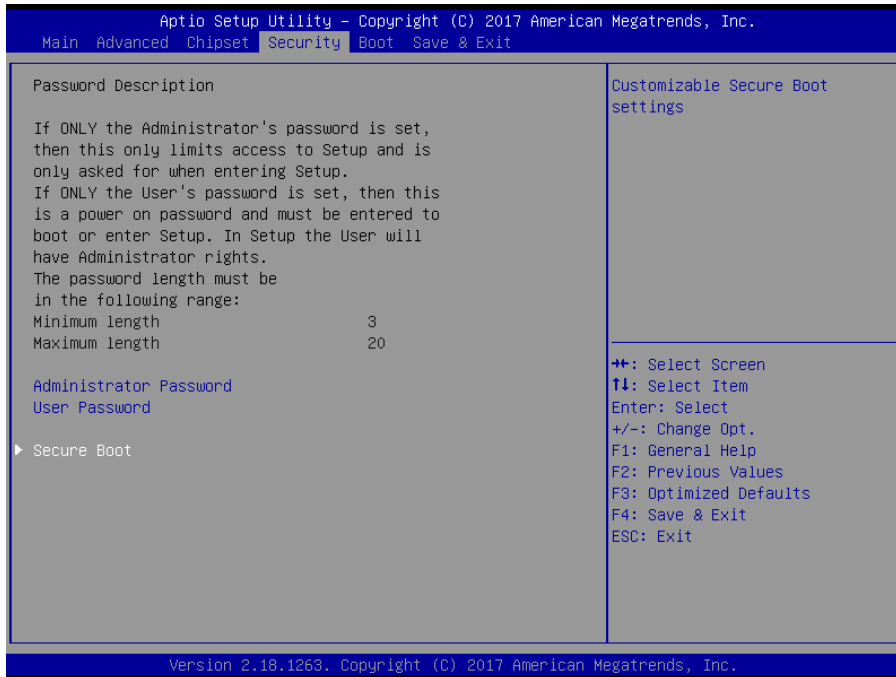

- **Administrator Password**

Set setup Administrator Password

- **User Password**

Set User Password

### 3.6.4.1 Secure Boot menu

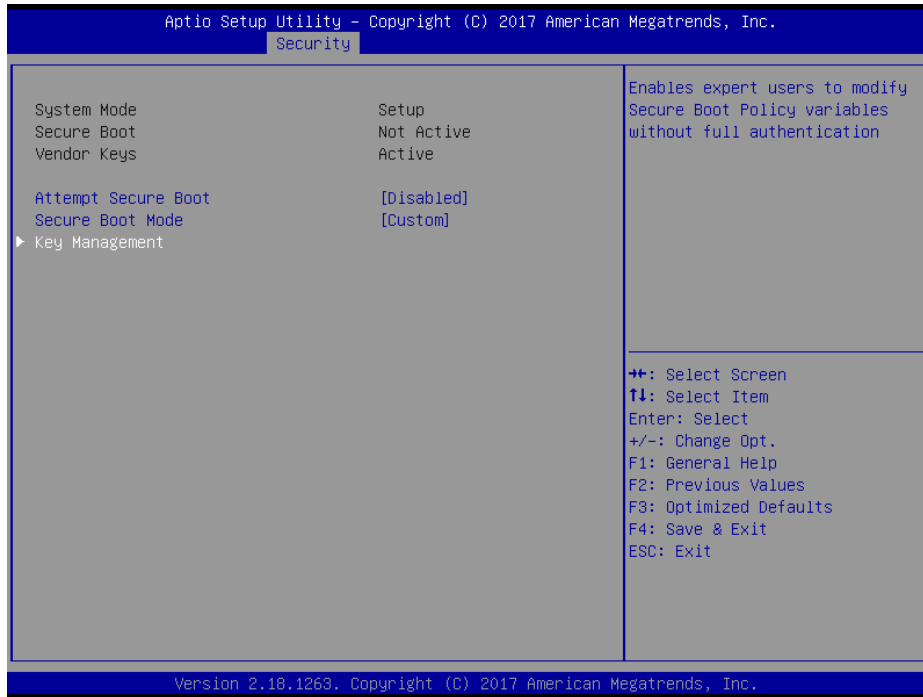

Item	Option	Description
<b>Attempt Secure Boot</b>	Disabled[Default] Enabled	Secure Boot activated when Platform Key(PK) is enrolled, System mode is User/Deployed, and CSM function is disabled.
<b>Secure Boot Mode</b>	Standard Custom[Default]	Secure Boot mode selector. 'Custom' Mode enables users to change Image Execution policy and manage Secure Boot Keys.

#### 3.6.4.1.1 Key Management

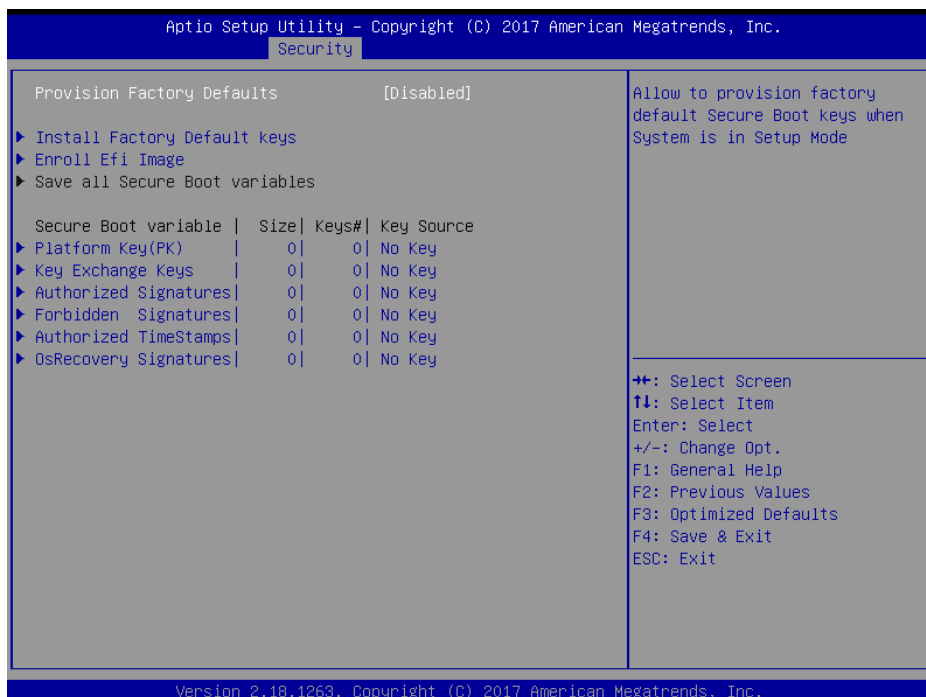

# EMX-Q170KP User's Manual

Item	Option	Description
Provision Factory Defaults	Enabled, Disabled[Default]	Allow to provision factory default Secure Boot keys when System is in Setup Mode.

## 3.6.5 Boot

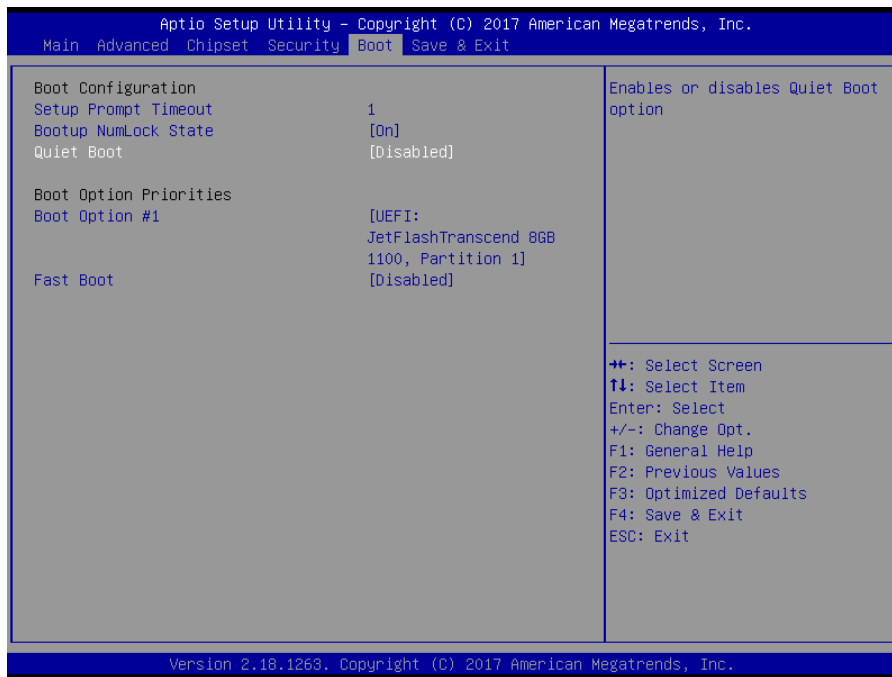

Item	Option	Description
Setup Prompt Timeout	1~ 65535	Number of seconds to wait for setup activation key. 65535(0xFFFF) means indefinite waiting.
Bootup NumLock State	On[Default] Off	Select the keyboard NumLock state
Quiet Boot	Disabled[Default] Enabled	Enables or disables Quiet Boot option
Fast Boot	Disabled[Default] Enabled	Enables or disables boot with initialization of a minimal set of devices required to launch active boot option. Has no effect for BBS boot options.
Boot Option #1	Set the system boot order.	

### 3.6.6 Save and exit

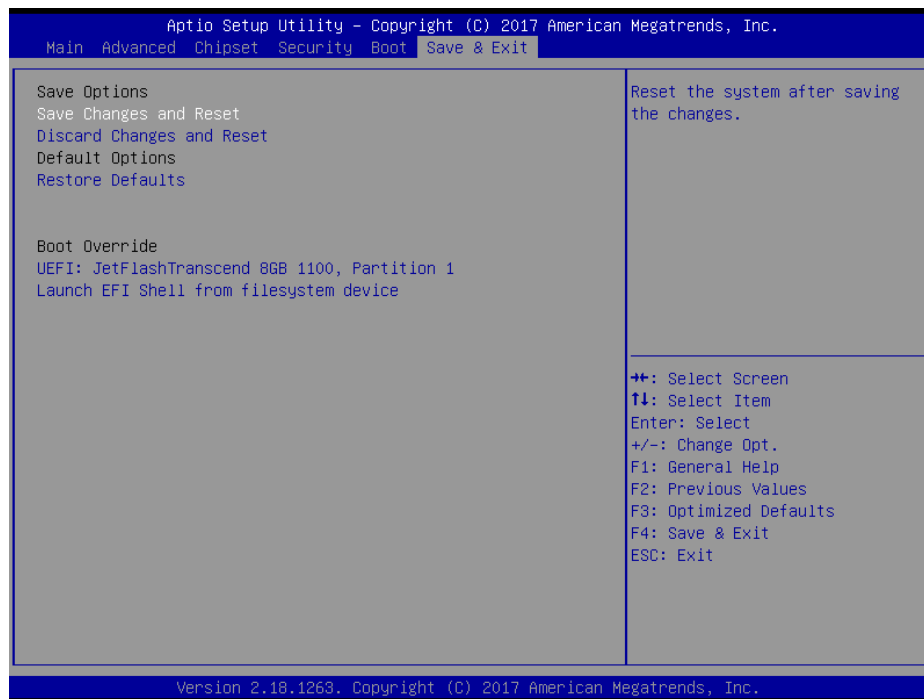

#### 3.6.6.1 Save Changes and Reset

Reset the system after saving the changes.

#### 3.6.6.2 Discard Changes and Reset

Any changes made to BIOS settings during this session of the BIOS setup program are discarded. The setup program then exits and reboots the controller.

#### 3.6.6.3 Restore Defaults

This option restores all BIOS settings to the factory default. This option is useful if the controller exhibits unpredictable behavior due to an incorrect or inappropriate BIOS setting.

#### 3.6.6.4 Launch EFI Shell from filesystem device

Attempts to Launch EFI Shell application (Shellx64.efi) from one of the available filesystem devices.

# 4. Drivers Installation

---



**Note:** Installation procedures and screen shots in this section are for your reference and may not be exactly the same as shown on your screen.



## 4.1 Install Chipset Driver

Insert the Supporting DVD-ROM to DVD-ROM drive, and it should show the index page of Avalue's products automatically. If not, locate Index.htm and choose the product from the menu left.



**Note:** The installation procedures and screen shots in this section are based on Windows 10 operation system. If the warning message appears while the installation process, click Continue to go on.

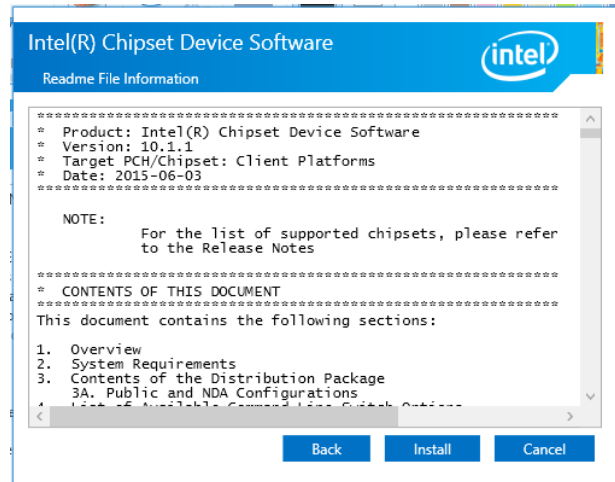

**Step 3. Click Install.**

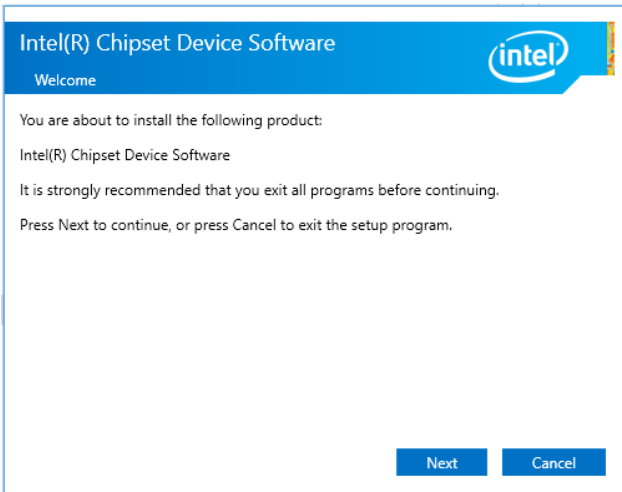

**Step1. Click Next.**

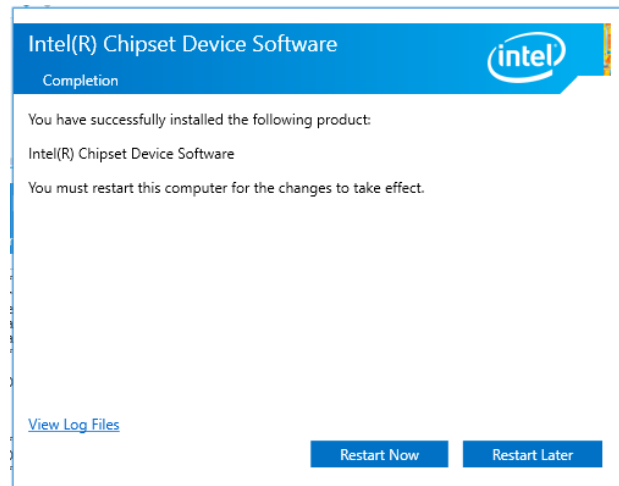

**Step 4. Complete setup.**

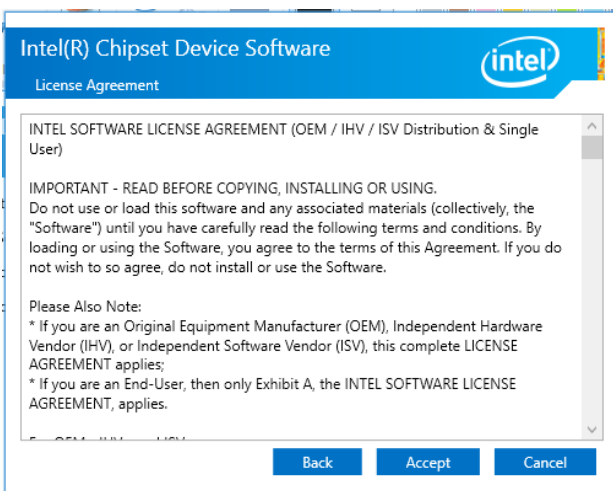

**Step 2. Click Accept.**

## 4.2 Install VGA Driver

Insert the Supporting DVD-ROM to DVD-ROM drive, and it should show the index page of Avalue's products automatically. If not, locate Index.htm and choose the product from the menu left.



**Note:** The installation procedures and screen shots in this section are based on Windows 10 operation system.

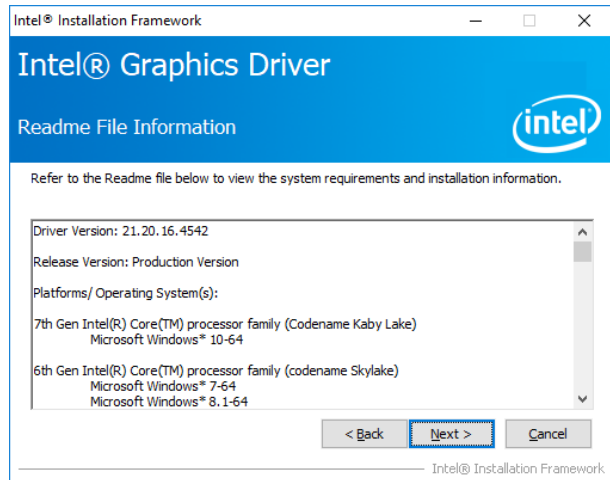

**Step 3. Click Next.**

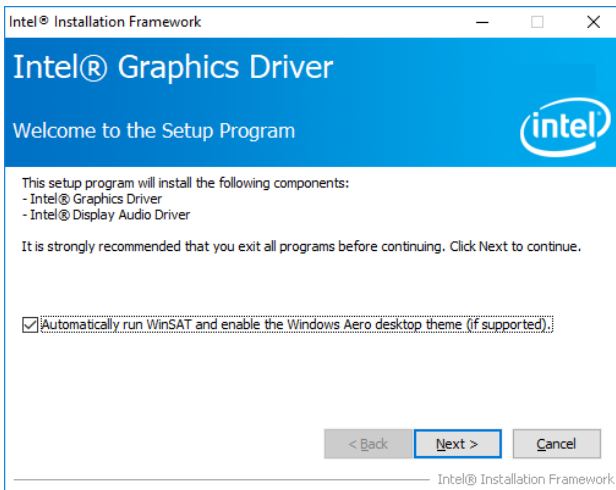

**Step 1. Click Next** to continue installation.

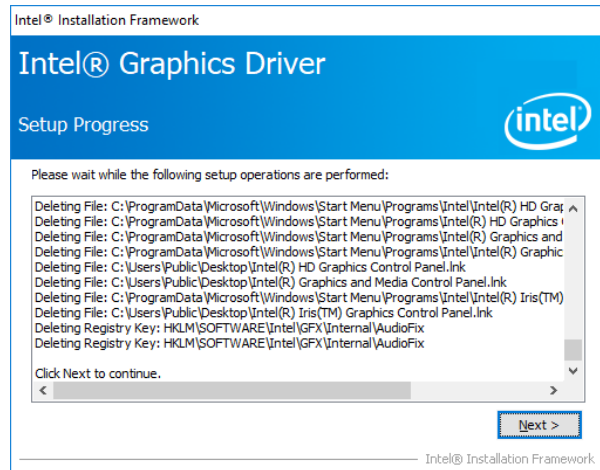

**Step 4. Click Next.**

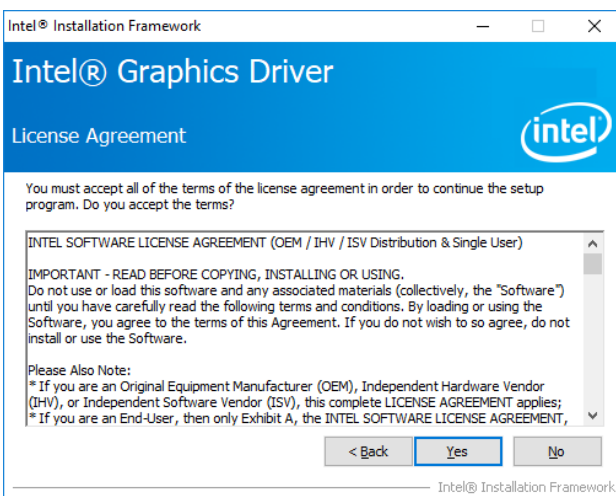

**Step 2.**

Click **Yes** to accept license agreement.

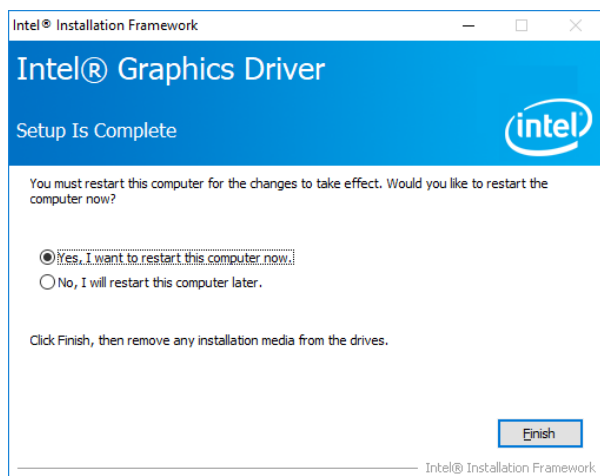

**Step 5. Click Finish** to complete setup.

## 4.3 Install SOL Driver

Insert the Supporting CD-ROM to CD-ROM drive, and it should show the index page of Avalue's products automatically. If not, locate Index.htm and choose the product from the menu left.



**Note:** The installation procedures and screen shots in this section are based on Windows 10 operation system.

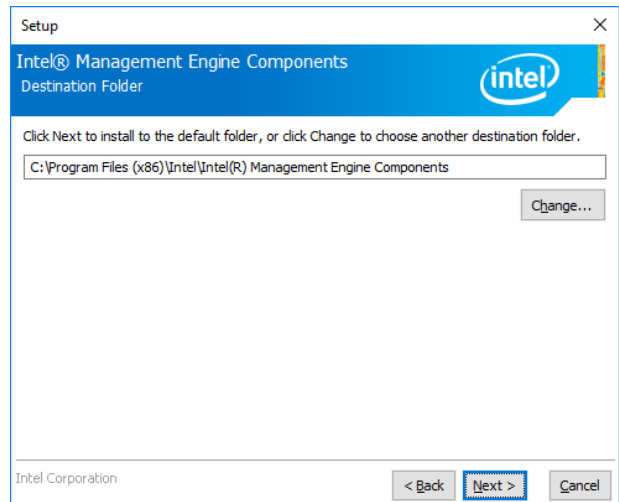

**Step 3. Click Next**

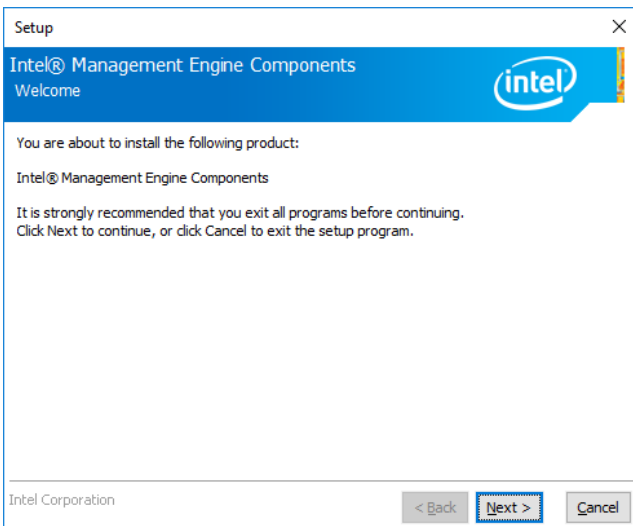

**Step 1. Click Next** to continue setup.

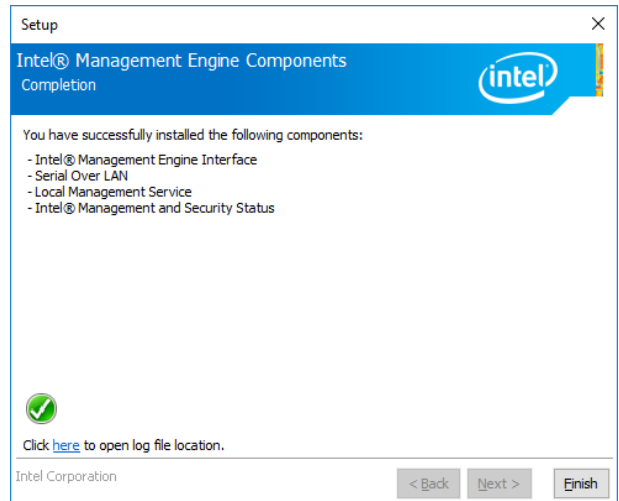

**Step 4. Click Finish** to complete the setup

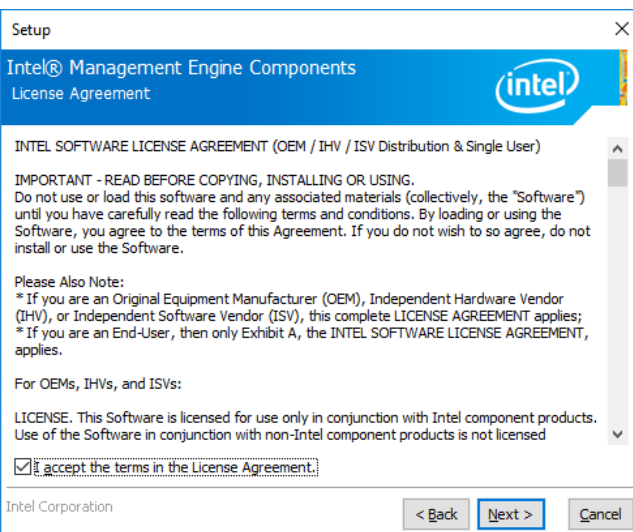

**Step 2. Click Next.**

## 4.4 Install Audio Driver (For Realtek ALC892 HD Audio)

Insert the Supporting DVD-ROM to DVD-ROM drive, and it should show the index page of Avalue's products automatically. If not, locate Index.htm and choose the product from the menu left.



**Note:** The installation procedures and screen shots in this section are based on Windows 10 operation system. If the warning message appears while the installation process, click Continue to go on.

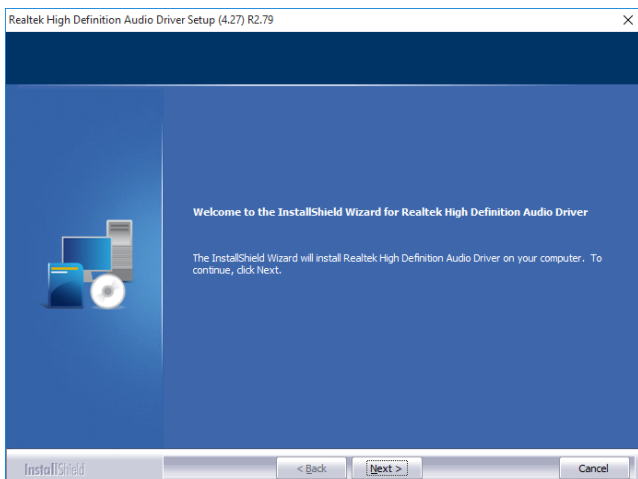

**Step1.** Click **Next** to Install.

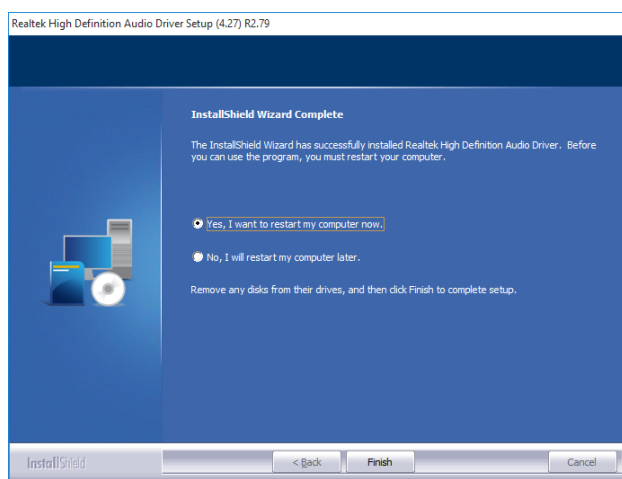

**Step 2.** Select **Finish** to complete Installation.

## 4.5 Install LAN Driver

Insert the Supporting DVD-ROM to DVD-ROM drive, and it should show the index page of Avalue's products automatically. If not, locate Index.htm and choose the product from the menu left.



**Note:** The installation procedures and screen shots in this section are based on Windows 10 operation system.

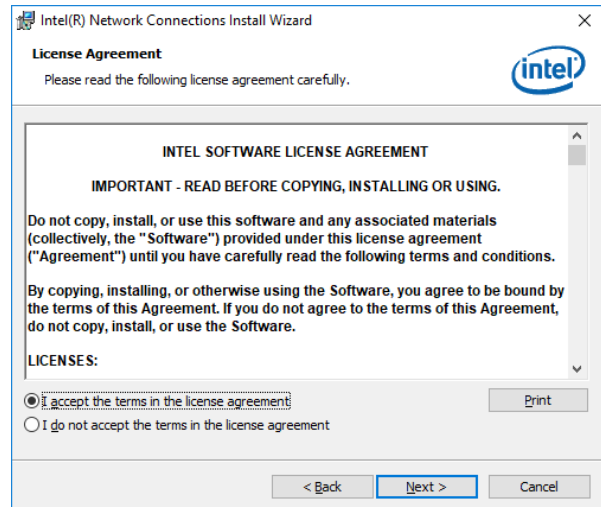

**Step 3. Click Next.**

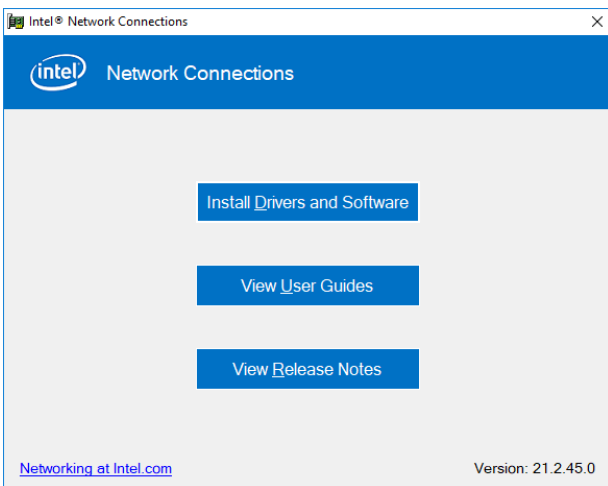

**Step 1. Click Install Drivers and Software.**

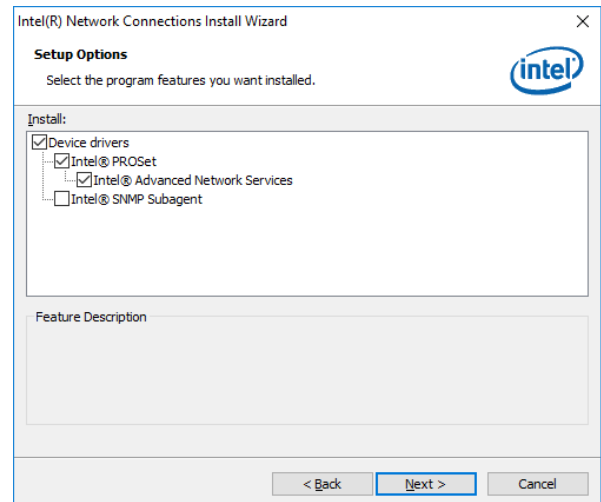

**Step 4. Click Next.**

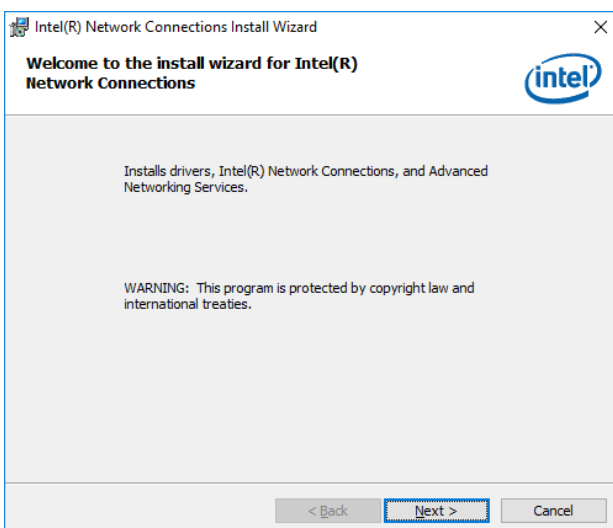

**Step 2. Click Next.**

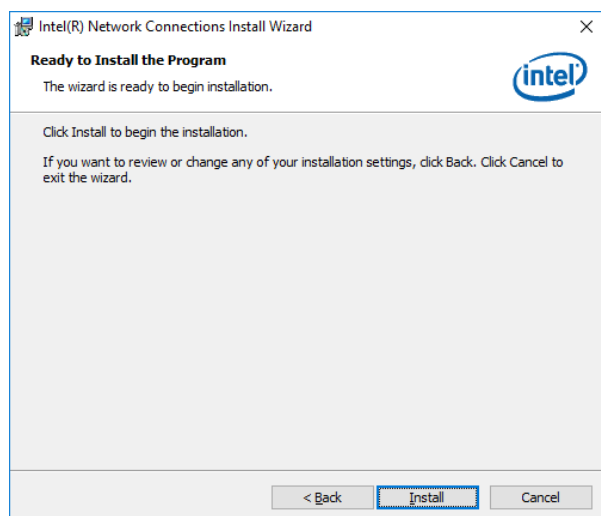

**Step 5. Click Install.**

## EMX-Q170KP User's Manual

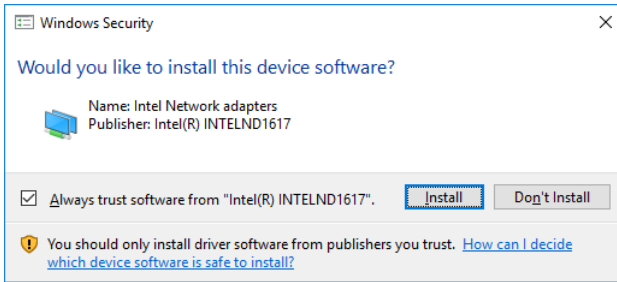

**Step 6. Click Install.**

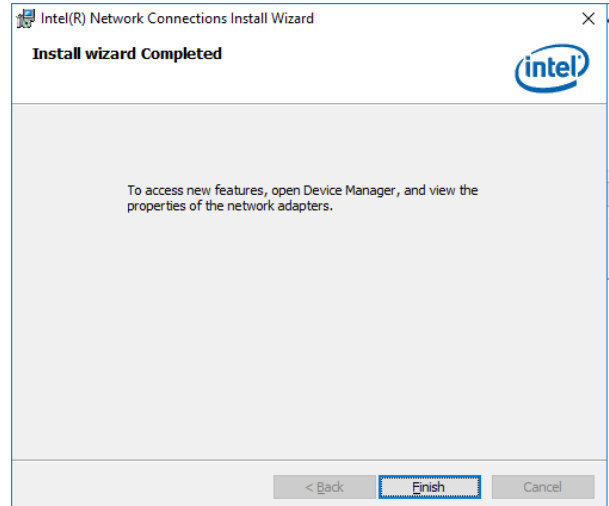

**Step 7. Click Finish to complete setup.**

## 4.6 Install RST Driver

Insert the Supporting DVD-ROM to DVD-ROM drive, and it should show the index page of Avalue's products automatically. If not, locate Index.htm and choose the product from the menu left.



**Note:** The installation procedures and screen shots in this section are based on Windows 10 operation system.

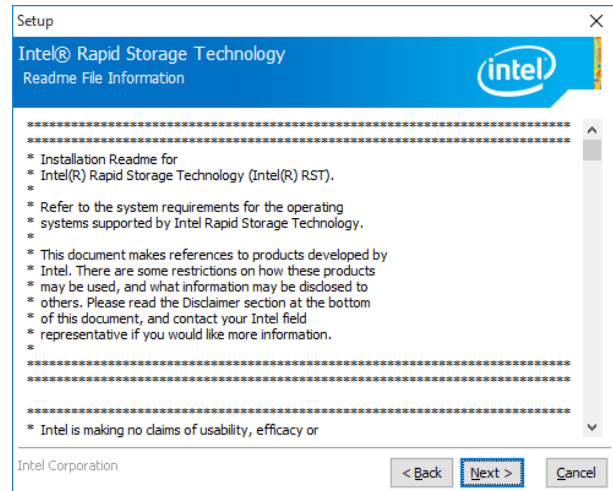

**Step 3. Click Next.**

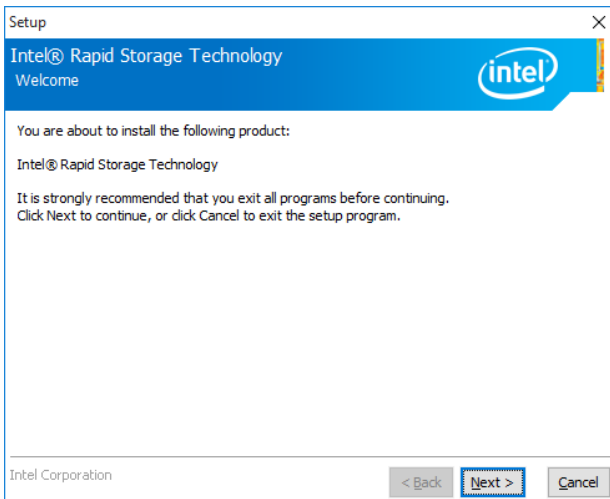

**Step 1. Click Next** to continue installation.

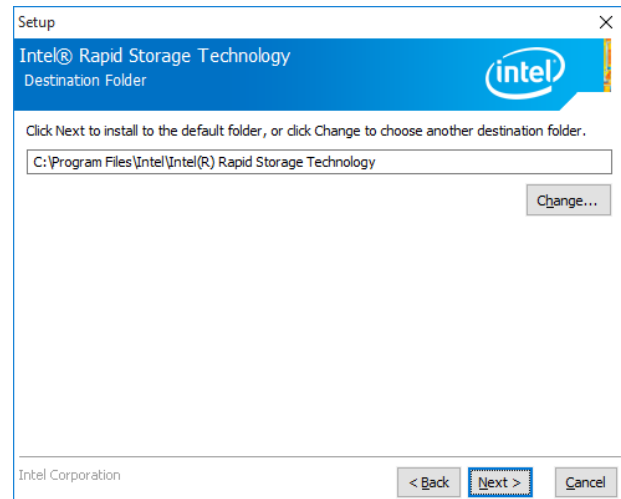

**Step 4. Click Next.**

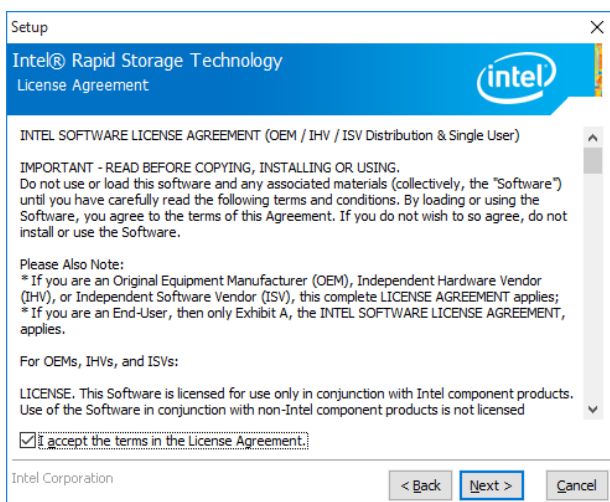

**Step 2. Click Next.**

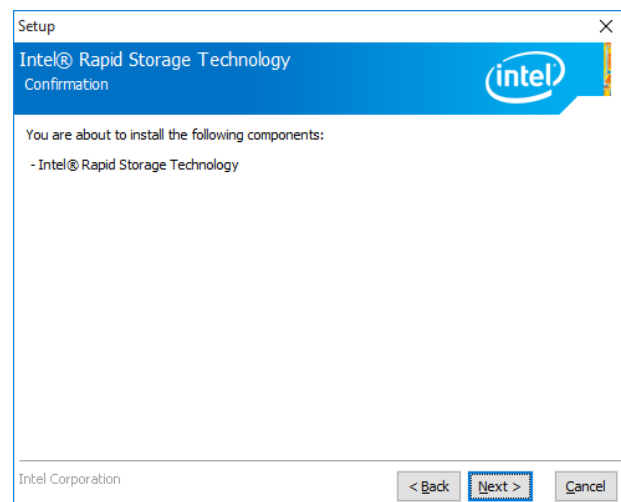

**Step 5. Click Finish** to complete setup.

## EMX-Q170KP User's Manual



**Step 6.** Click **Finish** to complete setup.



# 5. Mechanical Drawing



# EMX-Q170KP User's Manual

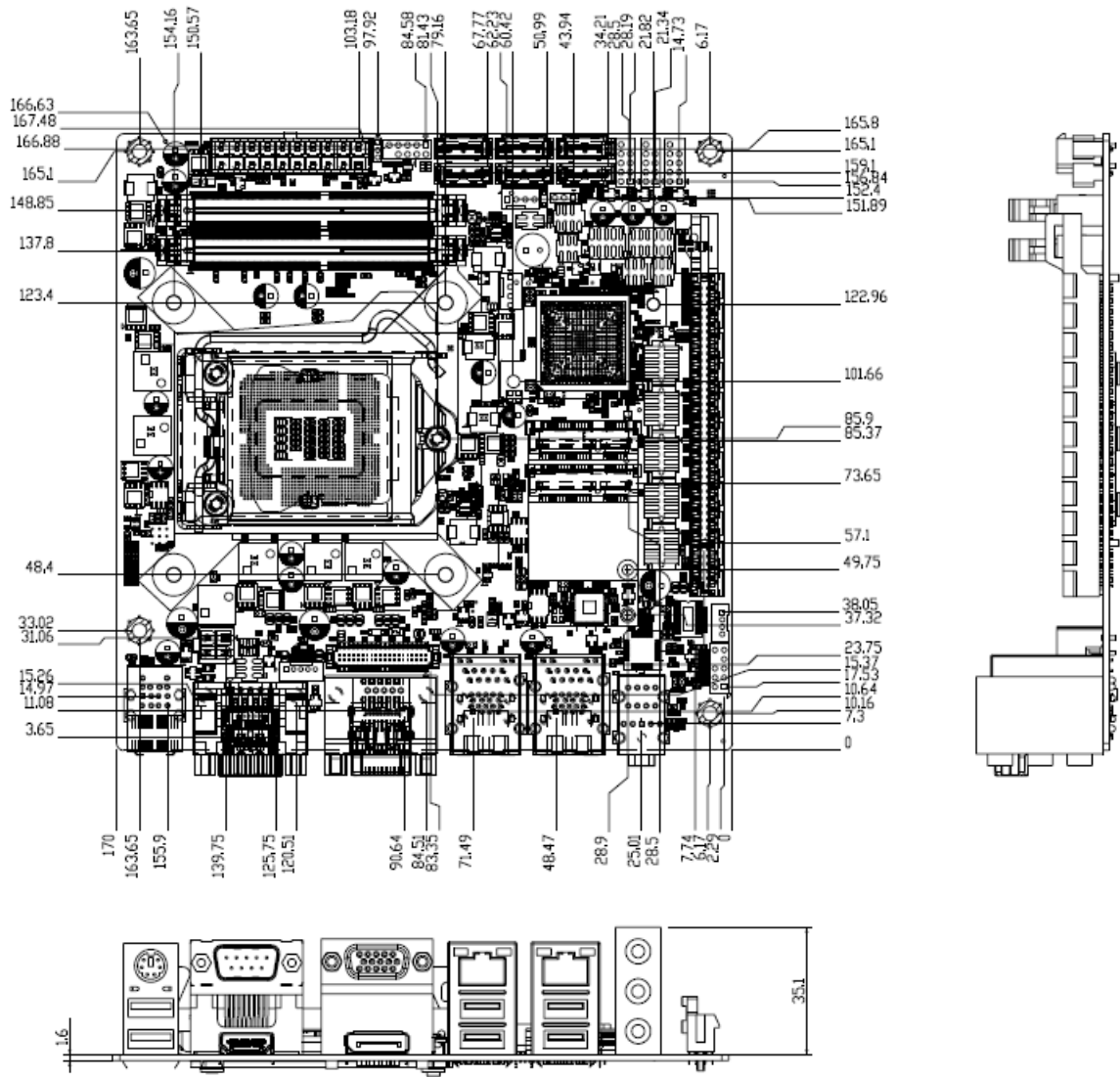

Unit: mm

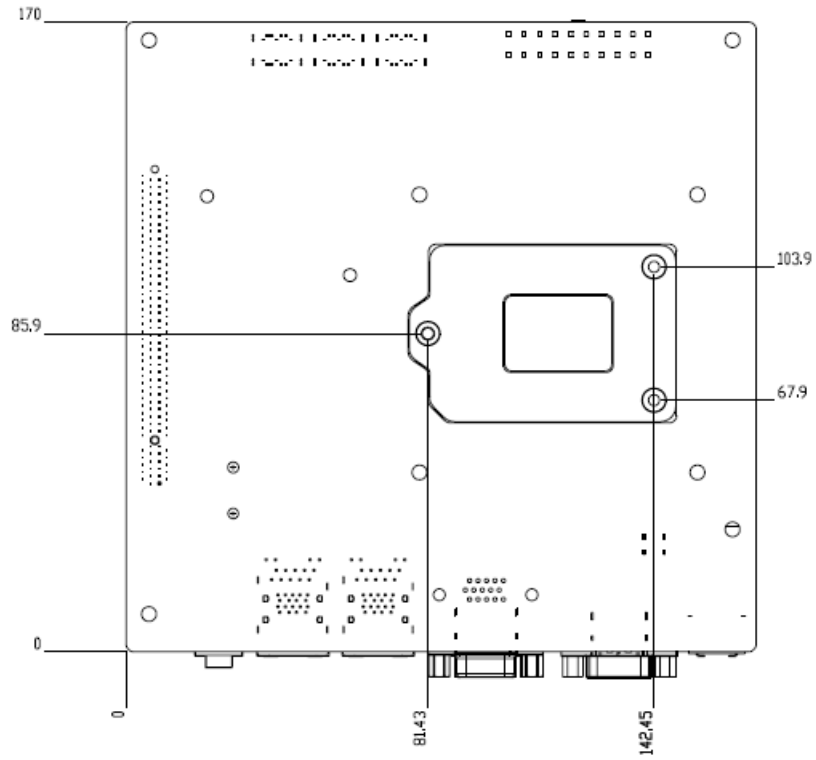

Unit: mm

