

規格書



SPECIFICATION

品名 SWITCHING POWER SUPPLY
 STYLE NAME :

型號 MRW-6420P-R(With FAN Speed Control)
 MODEL NO. :

料號
 PART NO. :

版次 A1
 REVISION :

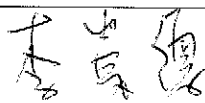
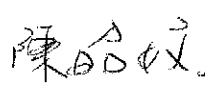
APPROVE 核准	 Jun. 17, 2010	正式資料 用章	
CHECK BY 審核	 Jun. 17, 2010		
FORM MAKER 經辦	 Jun. 17, 2010		

新巨企業股份有限公司
 電源事業處
 ZIPPY TECHNOLOGY CORP.
 POWER DIVISION

10F, NO. 50 MIN CHYUAN RD.,
 SHIN-TIEN CITY, TAIPEI HSIEN,
 TAIWAN, R.O.C.
 TEL. : +886(2)29188512
 FAX. : +886(2)29134969

Revision

Rev.	Page	Item	Date	Description

MODEL NO. MRW-6420P-R (W/FAN SPEED)

- 1.0 Scope
- 2.0 Input requirements
 - 2.1 Voltage
 - 2.2 Frequency
 - 2.3 Steady-state current
 - 2.4 Inrush current
 - 2.5 Power factor correction
- 3.0 Output requirements
 - 3.1 DC load requirements
 - 3.2 Regulation
 - 3.3 Ripple and noise
 - 3.3.1 Specification
 - 3.3.2 Ripple voltage test circuit
 - 3.4 Overshoot
 - 3.5 Efficiency
 - 3.6 Remote on/off control
- 4.0 Protection
 - 4.1 Input
 - 4.2 Output
 - 4.2.1 OPP
 - 4.2.2 OVP
 - 4.2.3 Short current
- 5.0 Power supply sequencing
 - 5.1 Turn on
 - 5.2 Hold up time
 - 5.3 Power off sequence
- 6.0 Signal requirements
 - 6.1 Power good signal
 - 6.2 Under voltage sense level
- 7.0 Environment
 - 7.1 Temperature
 - 7.2 Humidity
 - 7.3 Insulation resistance
 - 7.4 Dielectric withstanding voltage
 - 7.5 Leakage current
- 8.0 Safety
 - 8.1 UL & UL+C
 - 8.2 TUV
 - 8.3 CB

- 9.0 Reliability
 - 9.1 Burn in
- 10.0 Mechanical requirements
- 11.0 DC output cable drawing
- 12.0 FAN control function
- 13.0 Output power derating characteristics

1.0 Scope

This specification defines the performance characteristics of a grounded, single-phase, 420 watts, 6 output level power supply. This specification also defines world wide safety requirements and manufactures process test requirements.

2.0 Input requirements

2.1 Voltage (sinusoidal)

Full range 100~240 VAC (With $\pm 10\%$ tolerance)

2.2 Frequency

The input frequency range will be 50Hz/60Hz(± 3 Hz).

2.3 Steady-state current

8 / 4 amps maximum at any low/high range input voltage.

2.4 Inrush current

60/80 amps @110/220 VAC (at 25 degrees ambient cold start)

2.5 Power factor correction

PFC can reach the target of 95% @110V,full load, following the standard of IEC 61000-3-2, class D.

3.0 Output requirements

3.1 DC load requirements

Normal Output voltage	Load current		Regulation tolerance	
	Max.	Min	Max.	Min.
+5V	35	3.0	+5%	-5%
+12V	28	2.0	+6%	-6%
-5V	0.5	0.0	+10%	-10%
-12V	1.2	0.0	+10%	-10%
+3.3V	25	1.0	+5%	-5%
+5VSB	2	0.1	+5%	-5%

*** Neither +5V and +3.3V, nor +3.3V and +12V should exceed 48A***

*** +5V,+3.3V and +12V total output max:398W ***

When doing the cross regulation test(one output channel at high load and the other output channels at low load), it is requested to set the higher output channel at 80% max. of its spec., and the lower output channels at 20% max. of theirs.

3.2 Regulation

Output DC voltage	Line regulation
+5V	± 50 mV
-5V	± 50 mV
+12V	± 50 mV
-12V	± 50 mV
+3.3V	± 50 mV
+5VSB	± 50 mV

3.3 Ripple and noise

3.3.1 Specification

+5V	50mV (P-P)
+12V	120mV (P-P)
-5V	150mV (P-P)
-12V	150mV (P-P)
+3.3V	50mV (P-P)
+5VSB	60mV (P-P)

3.3.2 Ripple voltage test circuit

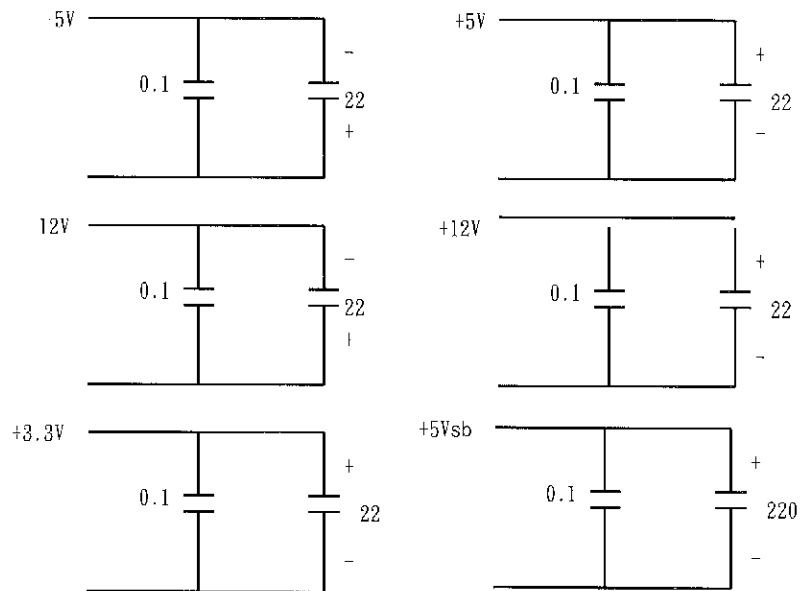

0.1uF is ceramic, the other is tantalum.

Noise bandwidth is from DC to 20Mhz

3.4 Overshoot

Any overshoot at turn on or turn off shall be less than 15% of the nominal voltage value, all output shall be within the regulation limit of section 3.1 before issuing the power good signal of section 6.0.

3.5 Efficiency

Power supply efficiency typical 63% at 115V, full load.

3.6 Remote on/off control

The power supply DC outputs (with the exception of +5VSB) shall be enabled with an active-low, TTL-compatible signal ("PS-ON")

When PS-ON is pulled to TTL low, the DC outputs are to be enabled.

When PS-ON is pulled to TTL high or open circuited, the DC outputs are to be disabled.

4.0 Protection

4.1 Input (primary)

The input power line must have an over power protection device in accordance with safety requirement of section 8.0

4.2 Output (secondary)

4.2.1 Over power protection

Over power protection at 110%~170% of rated output power .The power supply latches all DC output into a shutdown state. Over power of this type shall cause no damage to power supply , after over power is removed and a power on/off cycle is initiated , the power supply will restart.

4.2.2 Over voltage protection (This has to test the modules and backplane together)

If an over voltage fault occurs (internal of the power supply) , the power supply will latch all DC output into a shutdown state before

+5V : 5.7V ~ 6.6V

+3.3V : 3.7V ~ 4.1V

+12V : 13.0V ~ 14.6V

4.2.3 Short circuit (This has to test the modules and backplane together)

A: A short circuit placed on any DC output to DC return shall cause no damage.

B: The power supply shall be latched in case any short circuit is taken place at +5V,+3.3V,+12V output.

C: The power supply shall be auto-recovered in case any short circuit is taken place at -5V,-12V,+5VSB.

5.0 Power supply sequencing

5.1 Power on (see fig.1)

5.2 Hold up time

When power shutdown DC output 5V must be maintain 16msec in regulation limit at normal input voltage.

5.3 Power off sequence (see fig. 1)

6.0 Signal requirements

6.1 Power good signal (see fig. 1)

The power supply shall provide a "power good" signal to reset system logic , indicate proper operation of the power supply , and give advance warning of impending loss of regulation at turn off. This signal shall be a TTL compatible up level (2.4V to 5.25V) when +5V output voltage are present and above the minimum UV sense levels specified in paragraph 6.2 , or a down level (0.0V to 0.8V) when any output is below its minimum UV sense level.

At power on , the power good signal shall have a turn on delay of at least 100ms but not greater than 500ms after the output voltages have reached their respective minimum sense levels.

6.2 Under voltage (UV) sense levels		
Output		Minimum sense voltage
+5V		+4.50V
+3.3V		+2.50V

7.0 Environment

7.1 Temperature

Operating temperature	0 to 40 degrees centigrade
Non-Operating temperature	-20 to 80 degrees centigrade
Safety regulation temperature	Applied at room temperature (25°C)
Operating temperature from 0°C	should start from AC 100V

7.2 Humidity

Operating humidity	20% to 80%
Non-operating humidity	10% to 90%

7.3 Insulation resistance

Primary to secondary	: 20 meg. ohm min. 500 VDC
Primary to Frame Gnd	: 20 meg. ohm min. 500 VDC

7.4 Dielectric withstanding voltage

For approval purpose :

Primary to secondary	: 3KVAC for 1min.
Primary to Frame Gnd	: 1500 VAC for 1 min.

For production purpose: 100% test

Primary to Frame Gnd	: 1500VAC for 1 sec
Cut off current	: 15mA

7.5 Leakage current

3.5 mA. max. at nominal voltage 250 VAC

8.0 Safety

8.1 Recognized to U.S. and Canadian requirements under the component recognition program of Underwriters Laboratories Inc.
The power supply shall be designed to meet UL60950.

8.2 TUV Standards

The power supply shall be designed to meet TUV EN-60950.

8.3 CB

The power supply shall be designed to meet CB IEC 60950.

9.0 Reliability

9.1 Burn in

All products shipped to customer must be processed by burn-in. The burn- in shall be performed for 1 hour at full load.

10.0 Mechanical requirements

Physical dimension : 161 mm * 143 mm * 41.4 mm (D*W*H)

11.0 DC output cable drawing

(see attached drawing)

12.0 FAN control function

TEMP	RPM %	PS Load	
25	60	Light load f	
30	60		
35	60		
40	60		
45	60		
50	60		
55	60		
60	60		
65	60		45%
70	100		Over 45%
80	100		
90	100		

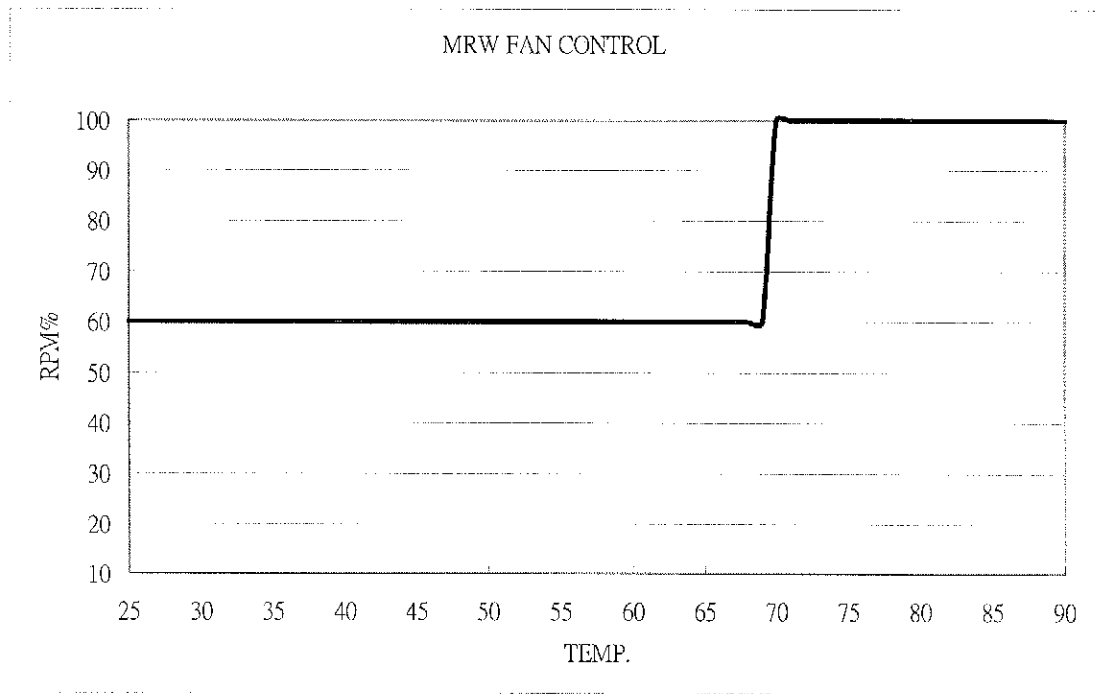

13.0 Output power derating characteristics

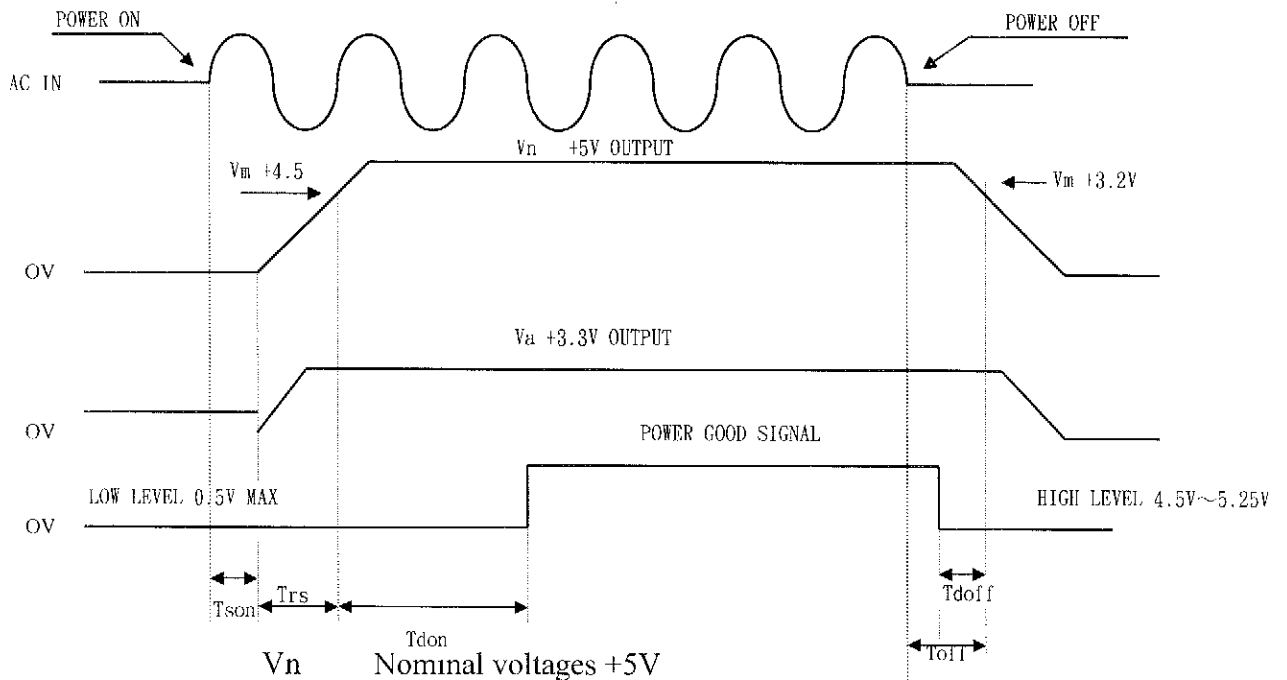
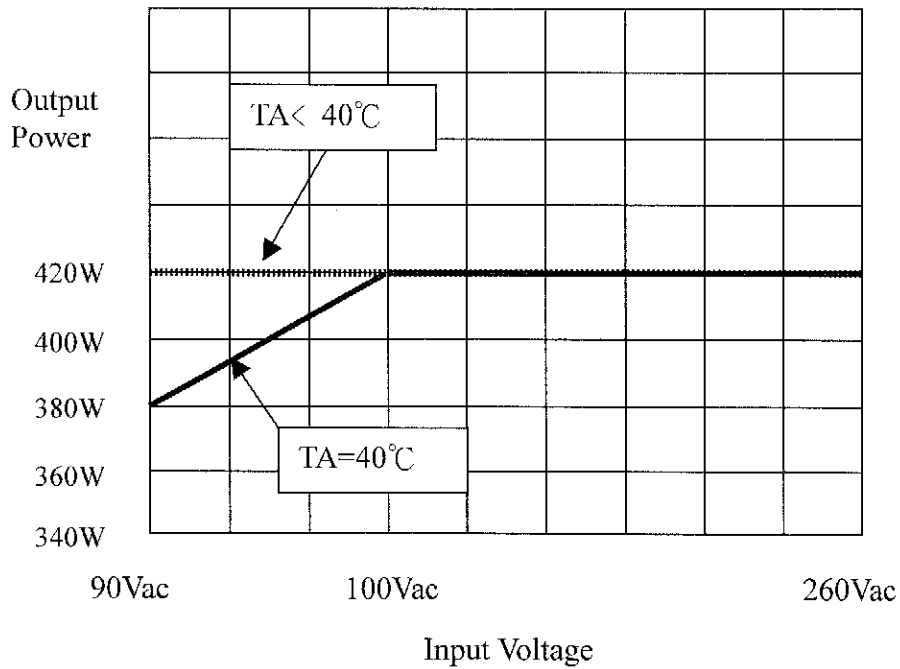

- V_n Nominal voltages +5V
- V_m Minimum voltages +4.5V
- V_a Nominal voltages +3.3V
- T_{son} Switch on time(500ms. Max)
- T_{rs} +5V rise time (100ms. max.)
- T_{don} Delay turn-on
- T_{doff} Delay turn-off (1 ms. min.)
- T_{off} Hold up time (16ms. min.)

《Figure 1》