

M.2 (P42)

3TE6 Series

Customer: _____

Customer

Part

Number: _____

Innodisk

Part

Number: _____

Innodisk

Model Name: _____

Date: _____

Innodisk Approver	Customer Approver

**Total Solution For
Industrial Flash Storage**

Features:

- PCIe Gen.3 x 4, NVMe SSD
- Kioxia 3D TLC NAND
- M.2 2242-D2-M
- Standard/Wide-temperature for BiCS3/4/5 (64/96/112 Layers NAND)
- With iPowerguard Design
- With iDataguard Design
- Dynamic Thermal Management
- Hybrid Write Mode with SLC Cache Enable
- AES-256 Bits Encryption Optional, Default disable
- Write Protect Optional, Default enable
- Quick Erase Optional, Default disable

Performance:

- Sequential Read up to 2,050 MB/s
- Sequential Write up to 1,900 MB/s

Power Requirements:

Input Voltage:	3.3V± 5%
Max Operating Wattage:	4.0W
Idle Wattage:	1.1W

Reliability:

Capacity	TBW	DWPD
64GB	27	0.39
128GB	93	0.68
256GB	206	0.75
512GB	471	0.86
1TB	1086	1

Data Retention	10 Years
Warranty	3 Years

For warranty details, please refer to:

https://www.innodisk.com/en/support_and_service/warranty

Table of contents

1. PRODUCT OVERVIEW	8
1.1 INTRODUCTION OF INNODISK M.2 (P42) 3TE6.....	8
1.2 PRODUCT VIEW AND MODELS	8
1.3 PCIe INTERFACE	9
2. PRODUCT SPECIFICATIONS	10
2.1 CAPACITY AND DEVICE PARAMETERS.....	10
2.2 PERFORMANCE	11
2.3 ELECTRICAL SPECIFICATIONS	14
2.3.1 Power Requirement.....	14
2.3.2 Power Consumption	14
2.4 ENVIRONMENTAL SPECIFICATIONS	15
2.4.1 Temperature Ranges	15
2.4.2 Humidity.....	15
2.4.3 Shock and Vibration	15
2.4.4 Mean Time between Failures (MTBF)	15
2.5 CE AND FCC COMPATIBILITY	15
2.6 RoHS COMPLIANCE	15
2.7 RELIABILITY	16
2.8 TRANSFER MODE	16
2.9 PIN ASSIGNMENT	17
2.10 MECHANICAL DIMENSIONS.....	19
2.11 ASSEMBLY WEIGHT	20
2.12 SEEK TIME	20
2.13 NAND FLASH MEMORY.....	20
2.14 HEAT-SPREADING COPPER LAYER.....	20
3. THEORY OF OPERATION	21
3.1 OVERVIEW.....	21
3.2 PCIe GEN III x 4 CONTROLLER.....	21
3.3 ERROR DETECTION AND CORRECTION.....	22
3.4 WEAR-LEVELING	22
3.5 BAD BLOCKS MANAGEMENT	22
3.6 GARBAGE COLLECTION/TRIM	22
3.7 END TO END DATA PATH PROTECTION	22
3.8 THERMAL MANAGEMENT	23
3.9 iDATAGUARD.....	23
3.10 AES FUNCTION (OPTIONAL).....	23
4. INSTALLATION REQUIREMENTS	23

- 4.1 M.2 (P42) 3TE6 PIN DIRECTIONS..... 23**
- 4.2 ELECTRICAL CONNECTIONS FOR M.2 (P42) 3TE6 24**
- 4.3 DEVICE DRIVE 24**
- 5. SMART / HEALTH INFORMATION.....25**
 - 5.1 GET LOG PAGE(LOG IDENTIFIER 02H) 25**
- 6. PART NUMBER RULE30**

REVISION HISTORY

Revision	Description	Date
1.0	First Release	Aug., 2020
1.1	Update Partial Information of 1TB WT model	Sep., 2020
1.2	Update BiCS4 Models	Sep., 2020
1.3	Update Mechanical Drawings	Sep., 2020
1.4	Update iDataGuard Correct 4.2 Electrical Connection Description	Nov., 2020
1.5	Update Pin Assignment	Jun., 2021
2.0	Add 112L 3D TLC Information TPS format adjustment Performance and TBW adjustment according to [PCN_F2136] PCIe 3TE6 Firmware Update	Oct., 2021
2.1	Update Data Retention	Dec., 2021
2.2	Update Naming rule	Jun., 2022
2.3	Add 112-Layer NAND WT	Oct., 2022

List of Tables

TABLE 1: DEVICE PARAMETERS	10
TABLE 2: PERFORMANCE - 64 LAYERS 3D TLC	11
TABLE 3: PERFORMANCE - 96 LAYERS 3D TLC	12
TABLE 4: PERFORMANCE- 112 LAYERS 3D TLC	13
TABLE 5: INNODISK M.2 (P42) 3TE6 POWER REQUIREMENT	14
TABLE 6: POWER CONSUMPTION - 64 LAYERS 3D TLC	14
TABLE 7: POWER CONSUMPTION - 96 LAYERS 3D TLC	14
TABLE 8: POWER CONSUMPTION - 112 LAYERS 3D TLC	14
TABLE 9: TEMPERATURE RANGE FOR M.2 (P42) 3TE6	15
TABLE 10: SHOCK/VIBRATION TESTING FOR M.2 (P42) 3TE6	15
TABLE 11: M.2 (P42) 3TE6 MTBF	15
TABLE 12: M.2 (P42) 3TE6 TBW	16
TABLE 13: INNODISK M.2 (P42) 3TE6 PIN ASSIGNMENT	17
TABLE 14: GET LOG PAGE – SMART / HEALTH INFORMATION LOG	25

List of Figures

FIGURE 1: INNODISK M.2 (P42) 3TE6 (TYPE 2242)	8
FIGURE 2: INNODISK M.2 (P42) 3TE6 DIAGRAM	19
FIGURE 3: INNODISK M.2 (P42) 3TE6 WITH HEAT-SPREADING COPPER LAYER DIAGRAM	19
FIGURE 4: INNODISK M.2 (P42) 3TE6 BLOCK DIAGRAM	21
FIGURE 5: SIGNAL SEGMENT AND POWER SEGMENT	23

1. Product Overview

1.1 Introduction of Innodisk M.2 (P42) 3TE6

Innodisk M.2 (P42) 3TE6 is a NVM Express DRAM-less SSD designed with PCIe interface and industrial 3D TLC NAND Flash. M.2 (P42) 3TE6 supports PCIe Gen III x 4 and it is compliant with NVM 1.3 providing excellent top and also sustained performance. With sophisticated error detection and correction (ECC) functions, the module can ensure full End-to-End data path protection that secures the data transmission between host system and NAND Flash. In addition, with embedded AES-256 bit engine, your data can be further secured.

1.2 Product View and Models

Innodisk M.2 (P42) 3TE6 is available in follow capacities with industrial 3D TLC flash ICs.

M.2 (P42) 3TE6 64GB

M.2 (P42) 3TE6 128GB

M.2 (P42) 3TE6 256GB

M.2 (P42) 3TE6 512GB

M.2 (P42) 3TE6 1TB

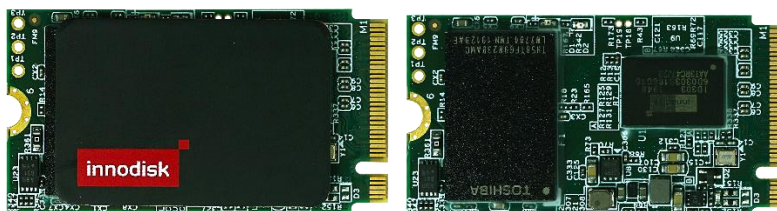

Figure 1: Innodisk M.2 (P42) 3TE6 (type 2242)

1.3 PCIe Interface

Innodisk M.2 (P42) 3TE6 supports PCIe Gen III interface and compliant with NVMe 1.3. M.2 (P42) 3TE6 can work under PCIe Gen 1, Gen 2 and Gen 3.

Most of operating system includes NVMe in-box driver now. For more information about the driver support in each OS, please visit <http://nvmexpress.org/resources/drivers>.

2. Product Specifications

2.1 Capacity and Device Parameters

M.2 (P42) 3TE6 device parameters are shown in Table 1.

Table 1: Device parameters

Capacity	Cylinders	Heads	Sectors	LBA	User Capacity(MB)
64GB	16383	16	63	117231408	57242
128GB				234441648	114473
256GB				468862128	228937
512GB				937703088	457863
1TB				1875385008	915715

2.2 Performance

Burst Transfer Rate: 4 GB/s

Table 2: Performance - 64 Layers 3D TLC

Capacity	Unit	64GB	128GB	256GB	512GB	1TB
Sequential** Read (Q32T1)	MB/s	640	1,200	1,600	1,600	2,000
Sequential** Write (Q32T1)		110	530	600	1,600	1,900
Sustained Sequential Read (Avg.) ***		420	540	490	960	960
Sustained Sequential Write (Avg.) ***		80	160	180	640	1,000
4KB Random** Read (Q8T8)	IOPS	37,000	77,000	86,000	235,000	285,000
4KB Random** Write (Q8T8)		20,000	41,000	55,000	298,000	343,000

Note: * Performance results are measured in Room Temperature with Out-of-Box devices and may vary depending on overall system setup. In addition, 3TE6 series adopt hybrid mode which enables SLC Cache up to 3% of total user capacity followed by TLC direct write to strike balance between burst performance and steady overall stability.

Note: ** Performance results are based on CrystalDiskMark 6.0.2 with file size 1000MB. Unit of 4KB items is I.O.P.S.

Note: *** Performance results are based on AIDA 64 v5.98 with block size 1MB of Linear Read & Write Test Item.

Table 3: Performance - 96 Layers 3D TLC

Capacity	Unit	128GB	256GB	512GB	1TB
Sequential** Read (Q32T1)	MB/s	780	1,150	2,000	2,000
Sequential** Write (Q32T1)		290	600	1,200	1,850
Sustained Sequential Read (Avg.) ***		320	650	800	930
Sustained Sequential Write (Avg.) ***		90	180	360	660
4KB Random** Read (Q8T8)	IOPS	43,000	88,000	165,000	290,000
4KB Random** Write (Q8T8)		23,000	45,000	220,000	257,000

Note: * Performance results are measured in Room Temperature with Out-of-Box devices and may vary depending on overall system setup. In addition, 3TE6 series adopt hybrid mode which enables SLC Cache up to 3% of total user capacity followed by TLC direct write to strike balance between burst performance and steady overall stability.

Note: ** Performance results are based on CrystalDiskMark 6.0.2 with file size 1000MB. Unit of 4KB items is I.O.P.S.

Note: *** Performance results are based on AIDA 64 v5.98 with block size 1MB of Linear Read & Write Test Item.

Table 4: Performance- 112 Layers 3D TLC

Capacity	Unit	128GB	256GB	512GB	1TB
Sequential* Read (Q32T1)	MB/s	780	1,600	2,050	2,050
Sequential* Write (Q32T1)		550	1,150	1,800	1,900
Sustained Sequential Read (Avg.)***		490	490	980	1,150
Sustained Sequential Write (Avg.)***		100	210	390	790
4KB Random** Read (Q8T8)	IOPS	49,000	99,000	189,000	305,000
4KB Random** Write (Q8T8)		25,000	143,000	322,000	351,000

Note: * Performance results are 3TE6 with Kioxia BiCS5 NAND composition measured in Room Temperature with Out-of-Box devices and may vary depending on overall system setup. In addition, 3TE6 series adopt hybrid mode which enables SLC cache followed by TLC direct write to strike balance between burst performance and steady overall stability.

Note: ** Performance results are based on CrystalDiskMark 6.0.2 with file size 1000MB. Unit of 4KB item is IOPS.

Note: *** Performance results are based on AIDA 64 v5.98 with block size 1MB of Linear Read & Write Test Item.

2.3 Electrical Specifications

2.3.1 Power Requirement

Table 5: Innodisk M.2 (P42) 3TE6 Power Requirement

Item	Symbol	Rating	Unit
Input voltage	V _{IN}	+3.3 DC +- 5%	V

2.3.2 Power Consumption

Table 6: Power Consumption - 64 Layers 3D TLC

Model	Power Consumption (W)				
Capacity	64GB	128GB	256GB	512GB	1TB
Read (RMS)	1.9	2.2	2.6	2.9	3.2
Write (RMS)	1.8	1.8	2.6	3.7	3.8
Idle (RMS)	0.9	0.9	0.9	0.9	1.0
Power On Peak	2.3	2.9	3.1	3.3	3.3

Note: * Current results may vary depending on system components and power circuit design.

Table 7: Power Consumption - 96 Layers 3D TLC

Model	Power Consumption (W)			
Capacity	128GB	256GB	512GB	1TB
Read (RMS)	2.3	2.6	3.0	3.1
Write (RMS)	2.1	2.2	2.8	3.7
Idle (RMS)	1.0	1.0	1.0	0.9
Power-On Peak	2.0	3.1	3.1	3.3

Note: * Current results may vary depending on system components and power circuit design.

Table 8: Power Consumption - 112 Layers 3D TLC

Model	Power Consumption (W)			
Capacity	128GB	256GB	512GB	1TB
Read (RMS)	2.5	2.9	3.6	3.9
Write (RMS)	2.0	2.3	2.8	4.0
Idle (RMS)	1.0	1.0	1.0	1.0

Note: * Current results may vary depending on system components and power circuit design.

2.4 Environmental Specifications

2.4.1 Temperature Ranges

Table 9: Temperature range for M.2 (P42) 3TE6

Temperature	Range
Operating	Standard Grade: 0°C to +70°C Industry Grade: -40°C to +85°C
Storage	-40°C to +85°C

2.4.2 Humidity

Relative Humidity: 10-95%, non-condensing

2.4.3 Shock and Vibration

Table 10: Shock/Vibration Testing for M.2 (P42) 3TE6

Reliability	Test Conditions	Reference Standards
Vibration	7 Hz to 2K Hz, 20G, 3 axes	IEC 60068-2-6
Mechanical Shock	Duration: 0.5ms, 1500 G, 3 axes	IEC 60068-2-27

2.4.4 Mean Time between Failures (MTBF)

Table 7 summarizes the MTBF prediction results for various M.2 (P42) 3TE6 configurations. The analysis was performed using a RAM Commander™ failure rate prediction.

- **Failure Rate:** The total number of failures within an item population, divided by the total number of life units expended by that population, during a particular measurement interval under stated condition.
- **Mean Time between Failures (MTBF):** A basic measure of reliability for repairable items: The mean number of life units during which all parts of the item perform within their specified limits, during a particular measurement interval under stated conditions.

Table 11: M.2 (P42) 3TE6 MTBF

Product	Condition	MTBF (Hours)
Innodisk M.2 (P42) 3TE6	Telcordia SR-332 GB, 25°C	>3,000,000

2.5 CE and FCC Compatibility

M.2 (P42) 3TE6 conforms to CE and FCC requirements.

2.6 RoHS Compliance

M.2 (P42) 3TE6 is fully compliant with RoHS directive.

2.7 Reliability

Table 12: M.2 (P42) 3TE6 TBW

Parameter	Value	
Read Cycles	Unlimited Read Cycles	
Flash endurance	3,000 P/E cycles	
Error Correct Code	Support(LDPC)	
Data Retention	Under 40°C: 10 Years at Initial NAND Status; 1 Year at NAND Life End	
TBW* (Total Bytes Written) Unit: TB		
Capacity	Sequential workload	Client workload
64GB	170	27
128GB	340	93
256GB	680	206
512GB	1363	471
1TB	2727	1086
* Note:		
1. Sequential: Mainly sequential write are estimated by PassMark Burnin Test v8.1 pro.		
2. Client: Follow JESD218 Test method and JESD219A Workload, tested by ULINK. (The capacity lower than 64GB client workload is not specified in JEDEC219A, the values are estimated.)		
3. Based on out-of-box performance.		

2.8 Transfer Mode

M.2 (P42) 3TE6 support following transfer mode:

PCIe Gen III 4 GB/s

PCIe Gen II 2 GB/s

PCIe Gen I 1 GB/s

2.9 Pin Assignment

Innodisk M.2 (P42) 3TE6 follows standard M.2 spec, socket 3 key M PCIe-based SSD pinout. See Table 9 for M.2 (P42) 3TE6 pin assignment.

Table 13: Innodisk M.2 (P42) 3TE6 Pin Assignment

Signal Name	Pin #	Pin #	Signal Name
		75	GND
3.3V	74	73	GND
3.3V	72	71	GND
3.3V	70	69	NC
NC	68	67	NC
Notch	66	65	Notch
Notch	64	63	Notch
Notch	62	61	Notch
Notch	60	59	Notch
NC (Reserved)	58		
NC (Reserved)	56	57	GND
NC	54	55	REFCLKp
CLKREQ# (I/O)(0/3.3V)	52	53	REFCLKn
PERST# (I)(0/3.3V)	50	51	GND
NC	48	49	PERp0
NC	46	47	PERn0
NC	44	45	GND
NC (reserved for SMB_DATA)	42	43	PETp0
NC (reserved for SMB_CLK)	40	41	PETn0
NC	38	39	GND
NC	36	37	PERp1
NC	34	35	PERn1
NC	32	33	GND
NC	30	31	PETp1
NC (reserved for ROM code)	28	29	PETn1
NC	26	27	GND
NC	24	25	PERp2
NC	22	23	PERn2
NC	20	21	GND
3.3V	18	19	PETp2
3.3V	16	17	PETn2
3.3V	14	15	GND

3.3V	12	13	PERp3
LED1# (O) (OD)	10	11	PERn3
NC	8	9	GND
NC	6	7	PETp3
3.3V	4	5	PETn3
3.3V	2	3	GND
		1	GND

2.10 Mechanical Dimensions

M.2 Type 2242-D2-M

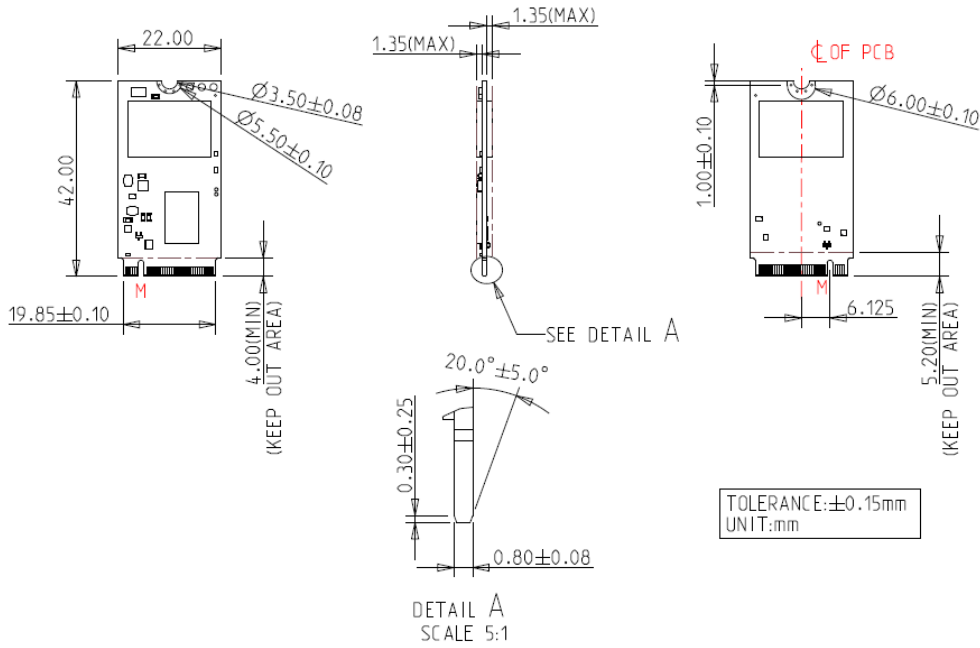

Figure 2: Innodisk M.2 (P42) 3TE6 diagram

M.2 Type 2242-D2-M with heat-spreading copper layer

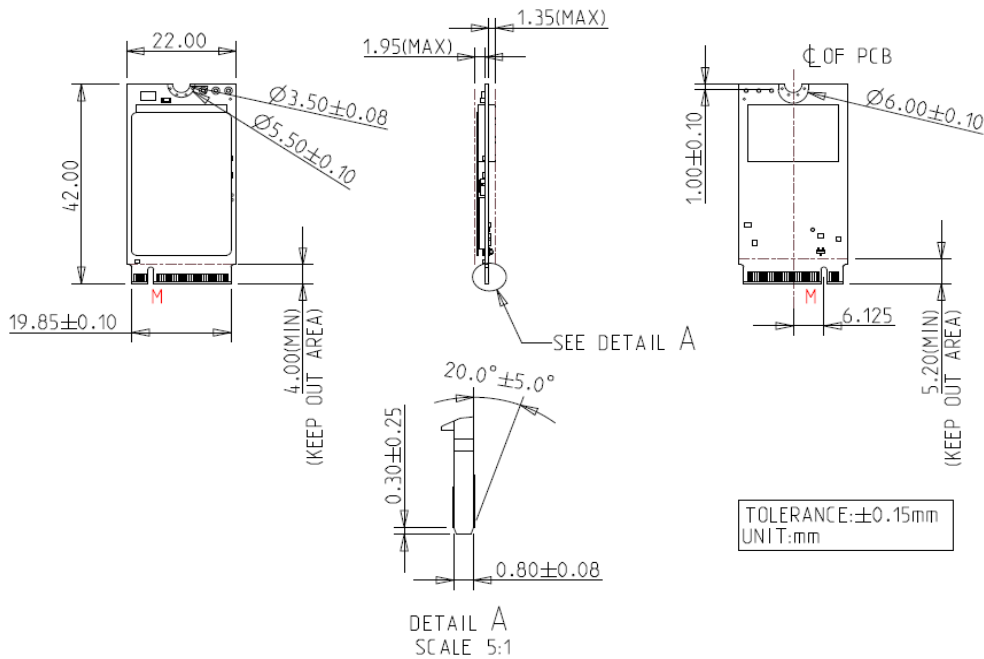

Figure 3: Innodisk M.2 (P42) 3TE6 with heat-spreading copper layer diagram

2.11 Assembly Weight

An Innodisk M.2 (P42) 3TE6 within NAND flash ICs, 128GB's weight is 7 grams approximately.

2.12 Seek Time

Innodisk M.2 (P42) 3TE6 is not of magnetic rotating design. There is no seek or rotational latency.

2.13 NAND Flash Memory

Innodisk M.2 (P42) 3TE6 uses industrial 3D TLC NAND flash memory, which is non-volatility, high reliability and high speed memory storage.

2.14 Heat-spreading copper layer

Innodisk M.2 (P42) 3TE6 industry temperature models come with a Heat-spreading copper layer installed on top of 3TE6 with dimension of 30x20x0.25 mm. This design will increase 3TE6's height to 1.95mm max due to the thermal pad and copper layer itself.

3. Theory of Operation

3.1 Overview

Figure 2 shows the operation of Innodisk M.2 (P42) 3TE6 from the system level, including the major hardware blocks.

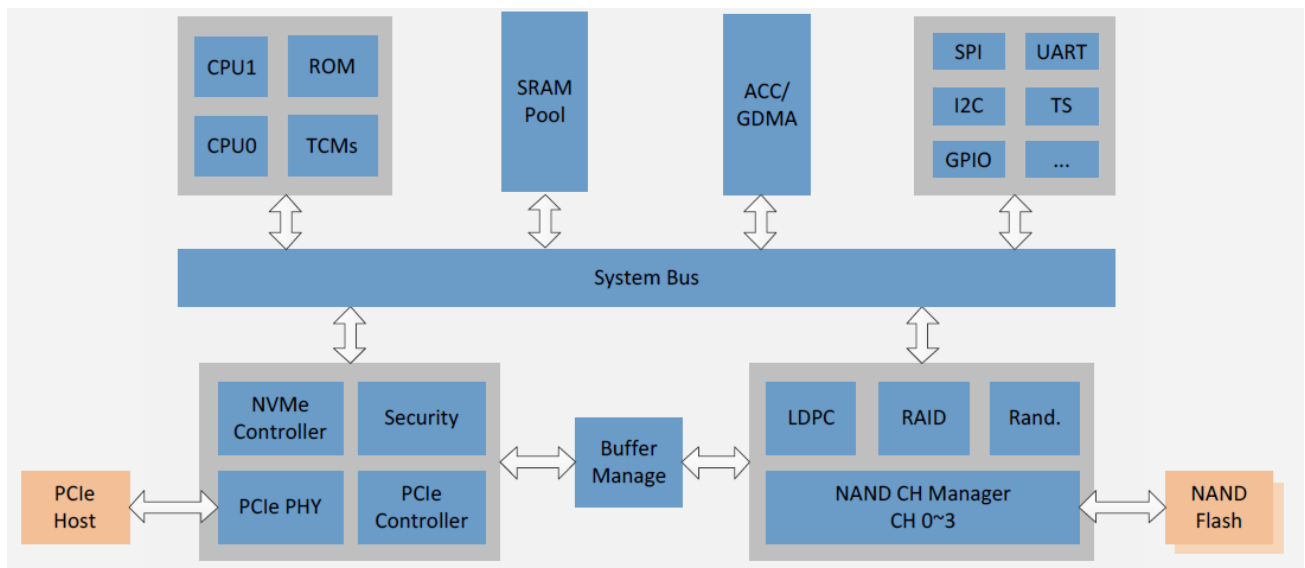

Figure 4: Innodisk M.2 (P42) 3TE6 Block Diagram

Innodisk M.2 (P42) 3TE6 integrates a PCIe Gen III x4 controller and NAND flash memories. Communication with the host occurs through the host interface, using the standard NVM protocol. Communication with the flash device(s) occurs through the flash interface.

3.2 PCIe Gen III x 4 Controller

Innodisk M.2 (P42) 3TE6 is designed with innodisk ID303, a PCIe Gen IIIx4 controller which is compliant with NVMe 1.3, up to 32.0Gbps transfer speed. In addition, it is compliant with PCIe Gen. 1, Gen. 2 and Gen. 3 specification. The controller supports up to four channels for flash interface.

3.3 Error Detection and Correction

Innodisk M.2 (P42) 3TE6 is designed with hardware LDPC ECC engine with hard-decision and soft-decision decoding. Low-density parity-check (LDPC) codes have excellent error correcting performance close to the Shannon limit when decoded with the belief-propagation (BP) algorithm using soft-decision information.

3.4 Wear-Leveling

Flash memory can be erased with a limited number of cycles. This number is called the **erase cycle limit** or **write endurance limit** and is defined by the flash NAND vendor. The erase cycle limit applies to each individual erase block in the flash device.

Innodisk M.2 (P42) 3TE6 uses a combination of two types of wear leveling- dynamic and static wear leveling- to distribute write cycling across an SSD and balance erase count of each block, thereby extending device lifetime.

3.5 Bad Blocks Management

Bad Blocks are blocks that contain one or more invalid bits whose reliability are not guaranteed. The Bad Blocks may be presented while the SSD is shipped, or may develop during the lifetime of the SSD. When a Bad Block is detected, it will be flagged as unusable block by firmware. The SSD implement Bad Blocks management that consists of Bad Blocks replacement and Error Correcting to avoid data error occurred. The functions will be enabled automatically to transfer data from Bad Blocks to spare blocks, and correct error bit.

3.6 Garbage Collection/TRIM

Garbage collection and TRIM technology is used to maintain data consistency and perform continual data cleansing on SSDs. It runs as a background process, freeing up valuable controller resources while sorting good data into available blocks, and deleting bad blocks. It also significantly reduces write operations to the drive, thereby increasing the SSD's speed and lifespan.

3.7 End to End Data Path Protection

End-to-end Data Path Protection that secures the data transmission between host system and NAND Flash. In the transmission path, no matter in or out, all buffer and storage implement Error Code Correction that optimizes the data integrity in the whole transmission of SSD.

3.8 Thermal Management

M.2 (P42) 3TE6 has built-in thermal sensor which can detect environment temperature of SSD. In the meantime, firmware will monitor the thermal sensor to prevent any failure of overheating. During extreme temperature, firmware will adjust the data transfer behavior to maintain the SSD’s reliable operation.

3.9 iDataGuard

Innodisk’s iData Guard is a comprehensive data protection mechanism that functions before and after a sudden power outage to the SSD. Low-power detection terminates data writing before an abnormal power-off, while table-remapping after power-on deletes corrupt data and maintains data integrity. Innodisk’s iData Guard provides effective power cycling management, preventing data stored in flash from degrading with use.

3.10 AES function (Optional)

M.2 (P42) 3TE6 has built-in AES-128/256 hardware encryption engine to encode and decode data to ensure efficiency and data security. In other words, there is no impact on CPU performance, as the controller will handle all encryption and decryption.

4. Installation Requirements

4.1 M.2 (P42) 3TE6 Pin Directions

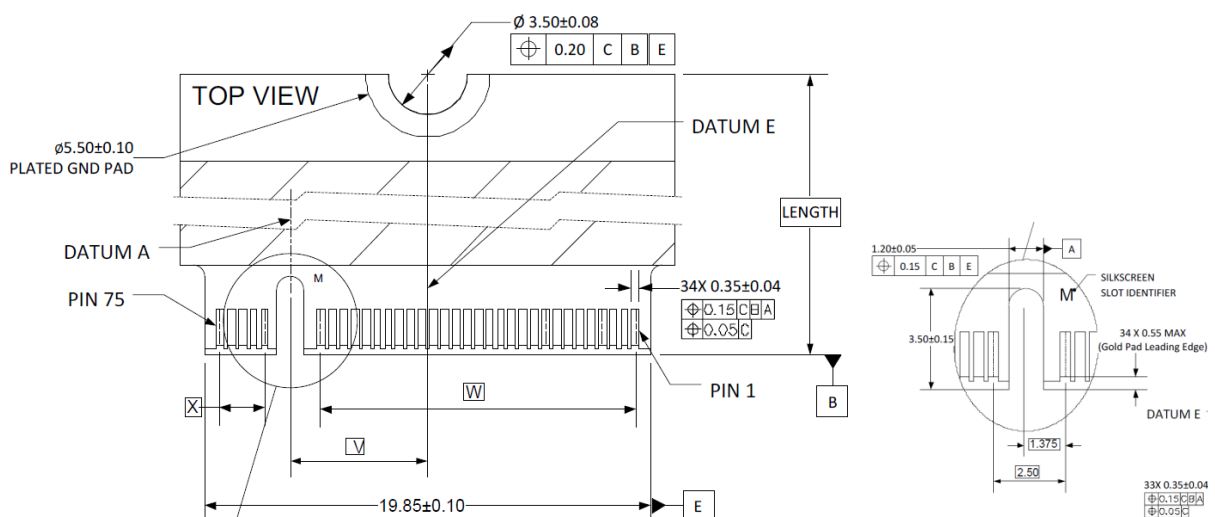

Figure 5: Signal Segment and Power Segment

4.2 Electrical Connections for M.2 (P42) 3TE6

M.2 interconnect is based on a 75 position Edge Card connector. The 75 position connector is intended to be keyed so as to distinguish between families of host interfaces and the various Sockets used in general Platforms. M.2(P42) 3TE6 is compliant with M.2 Socket 3 key M.

4.3 Device Drive

M.2(P42) 3TE6 is compliant with NVMe 1.3. Both Operation System and BIOS should include NVMe driver to compatible with NVMe device. Nowadays, most of OS includes NVMe in-box driver now. For more information about the driver support in each OS, please visit the website <http://nvmeexpress.org/resources/drivers>. For BIOS NVMe driver support please contact with motherboard manufacturers.

5. SMART / Health Information

This log page is used to provide SMART and general health information. The information provided is over the life of the controller and is retained across power cycles. More details about Set Features command; please refer to NVM Express 1.3

5.1 Get Log Page(Log Identifier 02h)

Innodisk 3TE6 series SMART / Health Information Log are listed in following table.

Table 14: Get Log Page – SMART / Health Information Log

Bytes	Description														
0	<p>Critical Warning: This field indicates critical warnings for the state of the controller. Each bit corresponds to a critical warning type; multiple bits may be set. If a bit is cleared to '0', then that critical warning does not apply. Critical warnings may result in an asynchronous event notification to the host. Bits in this field represent the current associated state and are not persistent.</p> <table border="1"> <thead> <tr> <th>Bit</th> <th>Definition</th> </tr> </thead> <tbody> <tr> <td>0</td> <td>If set to '1', then the available spare space has fallen below the threshold.</td> </tr> <tr> <td>1</td> <td>If set to '1', then a temperature is above an over temperature threshold or below an under</td> </tr> <tr> <td>2</td> <td>If set to '1', then the NVM subsystem reliability has been degraded due to significant media related</td> </tr> <tr> <td>3</td> <td>If set to '1', then the media has been placed in read only mode.</td> </tr> <tr> <td>4</td> <td>If set to '1', then the volatile memory backup device has failed. This field is only valid if the</td> </tr> <tr> <td>7:5</td> <td>Reserved</td> </tr> </tbody> </table>	Bit	Definition	0	If set to '1', then the available spare space has fallen below the threshold.	1	If set to '1', then a temperature is above an over temperature threshold or below an under	2	If set to '1', then the NVM subsystem reliability has been degraded due to significant media related	3	If set to '1', then the media has been placed in read only mode.	4	If set to '1', then the volatile memory backup device has failed. This field is only valid if the	7:5	Reserved
Bit	Definition														
0	If set to '1', then the available spare space has fallen below the threshold.														
1	If set to '1', then a temperature is above an over temperature threshold or below an under														
2	If set to '1', then the NVM subsystem reliability has been degraded due to significant media related														
3	If set to '1', then the media has been placed in read only mode.														
4	If set to '1', then the volatile memory backup device has failed. This field is only valid if the														
7:5	Reserved														
1:2	<p>Composite Temperature: Contains a value corresponding to a temperature in degrees Kelvin that represents the current composite temperature of the controller and namespace(s) associated with that controller. The manner in which this value is computed is implementation specific and may not represent the actual temperature of any physical point in the NVM subsystem. The value of this field may be used to trigger an asynchronous event.</p>														

	Warning and critical overheating composite temperature threshold values are reported by the WCTEMP and CCTEMP fields in the Identify Controller data structure.
3	Available Spare: Contains a normalized percentage (0 to 100%) of the remaining spare capacity available.
4	Available Spare Threshold: When the Available Spare falls below the threshold indicated in this field, an asynchronous event completion may occur. The value is indicated as a normalized percentage (0 to 100%).
5	Percentage Used: Contains a vendor specific estimate of the percentage of NVM subsystem life used based on the actual usage and the manufacturer's prediction of NVM life. A value of 100 indicates that the estimated endurance of the NVM in the NVM subsystem has been consumed, but may not indicate an NVM subsystem failure. The value is allowed to exceed 100. Percentages greater than 254 shall be represented as 255. This value shall be updated once per power-on hour (when the controller is not in a sleep state). Refer to the JEDEC JESD218A standard for SSD device life and endurance measurement techniques.
6:31	Reserved
32:47	Data Units Read: Contains the number of 512 byte data units the host has read from the controller; this value does not include metadata. This value is reported in thousands (i.e., a value of 1 corresponds to 1000 units of 512 bytes read) and is rounded up. When the LBA size is a value other than 512 bytes, the controller shall convert the amount of data read to 512 byte units. For the NVM command set, logical blocks read as part of Compare and Read operations shall be included in this value.
48:63	Data Units Written: Contains the number of 512 byte data units the host has written to the controller; this value does not include metadata. This value is reported in thousands (i.e., a value of 1 corresponds to 1000 units of 512 bytes written) and is rounded up. When the LBA size is a value other than 512 bytes, the controller shall convert the amount of data written to 512 byte units. For the NVM command set, logical blocks written as part of Write operations shall be included in this value. Write Uncorrectable commands shall not impact this value.
64:79	Host Read Commands: Contains the number of read commands completed by the controller. For the NVM command set, this is the number of Compare and Read commands.

80:95	<p>Host Write Commands: Contains the number of write commands completed by the controller.</p> <p>For the NVM command set, this is the number of Write commands.</p>
96:111	<p>Controller Busy Time: Contains the amount of time the controller is busy with I/O commands. The controller is busy when there is a command outstanding to an I/O Queue (specifically, a command was issued via an I/O Submission Queue Tail doorbell write and the corresponding completion queue entry has not been posted yet to the associated I/O Completion Queue). This value is reported in minutes.</p>
112:127	<p>Power Cycles: Contains the number of power cycles.</p>
128:143	<p>Power On Hours: Contains the number of power-on hours. This may not include time that the controller was powered and in a non-operational power state.</p>
144:159	<p>Unsafe Shutdowns: Contains the number of unsafe shutdowns. This count is incremented when a shutdown notification (CC.SHN) is not received prior to loss of power.</p>
160:175	<p>Media and Data Integrity Errors: Contains the number of occurrences where the controller detected an unrecovered data integrity error. Errors such as uncorrectable ECC, CRC checksum failure, or LBA tag mismatch are included in this field.</p>
176:191	<p>Number of Error Information Log Entries: Contains the number of Error Information log entries over the life of the controller.</p>
192:195	<p>Warning Composite Temperature Time: Contains the amount of time in minutes that the controller is operational and the Composite Temperature is greater than or equal to the Warning Composite Temperature Threshold (WCTEMP) field and less than the Critical Composite Temperature Threshold (CCTEMP) field in the Identify Controller data structure.</p> <p>If the value of the WCTEMP or CCTEMP field is 0h, then this field is always cleared to 0h regardless of the Composite Temperature value.</p>
196:199	<p>Critical Composite Temperature Time: Contains the amount of time in minutes that the controller is operational and the Composite Temperature is greater than the Critical Composite Temperature Threshold (CCTEMP) field in the Identify Controller data structure.</p> <p>If the value of the CCTEMP field is 0h, then this field is always cleared to 0h regardless of the Composite Temperature value.</p>
200:201	<p>Temperature Sensor 1: Contains the current temperature reported by controller's temperature sensor.</p>
202:203	<p>Temperature Sensor 2: Contains the current temperature reported by external temperature sensor.</p>

204:205	Temperature Sensor 3: Contains the current temperature reported by channel zero CE zero NAND's temperature sensor.
206:207	Temperature Sensor 4: Contains the current temperature reported by last channel CE zero NAND's temperature sensor.
208:209	Temperature Sensor 5: Contains the current temperature reported by temperature sensor 5.
210:211	Temperature Sensor 6: Contains the current temperature reported by temperature sensor 6.
212:213	Temperature Sensor 7: Contains the current temperature reported by temperature sensor 7.
214:215	Temperature Sensor 8: Contains the current temperature reported by temperature sensor 8.
216:219	Thermal Management Temperature 1 Transition Count: Lower Power Active Power States or Performed Vendor Specific Thermal Management
220:223	Thermal Management Temperature 2 Transition Count: Lower Power Active Power States or Performed Vendor Specific Thermal Management
224:227	Total Time For Thermal Management Temperature 1: Duration in Lower Power Active Power States or Performed Vendor Specific Thermal Management
228:231	Total Time For Thermal Management Temperature 2: Duration in Lower Power Active Power States or Performed Vendor Specific Thermal Management
232:337	Reserved
338:345	Later Bad Count
346:353	Power-On hours Count
354:361	Drive Power Cycle Count
362:369	Total Bad Block Count
370:377	User Max Erase Count
378:385	User Avg Erase Count
386:393	Device Life
394:401	Spare Block Count
402:409	Program Fail Count
410:417	Erase Fail Count
418:425	Unexpected Power Loss Count

426:433	Temperature (Kelvin - K °K)
434:441	Flash ID
442:449	Later Bad Block Info (Read / Write / Erase)
450:457	Total LBAs Written (uint = 32MB)
458:465	Total LBAs Read (uint = 32MB)

6. Part Number Rule

CODE	1	2	3	4	5	6	7	8	9	10	11	12	13	14	15	16	17	18	19	20	21
	D	E	M	2	4	-	A	2	8	D	D	1	E	C	A	D	F	-	X	X	X
Definition																					
Code 1st (Disk)											Code 14th (Operation Temperature)										
D : Disk											C: Standard Grade (0°C ~ +70°C)										
Code 2nd (Feature set)											Code 15th (Internal control)										
E : Embedded series											W: Industrial Grade (-40°C ~ +85°C)										
Code 3rd ~5th (Form factor)											Code 16th (Channel of data transfer)										
M24: M.2 Type 2242-D2-M											A~Z: BGA PCB version.										
Code 7th ~9th (Capacity)											Code 17th (Flash Type)										
64G: 64GB			A28: 128GB			B56: 256GB					D: Dual Channels										
C12: 512GB			01T: 1TB								Q: Quad Channels										
Code 10th ~12th (Controller)											Code 19th ~21th (Customize code)										
DD1: ID303 PCIe3.0x4											F: Kioxia 3D TLC										
DD2: ID303 PCIe3.0x4 with AES (by customization)																					
Code 13th (Flash mode)											Code 19th ~21th (Customize code)										
E: 64 Layer 3D TLC																					
G: 96 Layer 3D TLC																					
K: 112 Layers 3D TLC																					