

IP65 Stainless B Series Panel PC with Push Buttons

Intel® Celeron® N2930 (2M Cache, up to 2.16 GHz)

10.1" / 15" / 19" / 21.5"



Model No. W10IB3S-SPH2-B
R15IB3S-SPC3-B
R19IB3S-SPM1-B
W22IB3S-SPA3-B

User Manual

Contents

Preface	3
About This User Manual	6
Chapter 1: Introduction	7
1.1 Overview	7
1.2 Features	7
1.3 Package Content	8
1.4 Product Overview	9
1.5 Front Side USB Type-A Connector	11
1.6 Front Side Push Buttons	12
1.7 Rotary Switch for Touch Mode	13
1.8 Rear Side Physical Buttons	14
1.9 LED Indicators	14
Chapter 2: Installation	15
2.1 Mounting	15
2.1.1 VESA Mount	15
2.1.2 Yoke Mount	16
2.2 Connecting Peripherals	16
2.2.1 Power Connector	17
2.2.2 LAN Connector	17
2.2.3 USB Connector	17
2.2.4 USB Type-A Connector	18
2.2.5 RS-232 Connector	19
2.2.6 Connector 1 for Push Button Extension	19
2.2.7 Connector 2 for Push Button Extension	19
2.3 Cleaning the Monitor	20
Chapter 3: Operating the Device	20
3.1 Connecting to Power Source	20
3.2 Turning On/ Off the Device	22
3.3 Emergency Stop	22
3.4 Operating System	22
3.5 Multi-Touch	23
3.6 How to Enable Watchdog	24
Chapter 4: AMI BIOS Setup	25
4.1 Main Menu	26
4.2 Advanced Menu	27
4.2.2.1 ACPI Settings	29
4.2.2.2 F81866 Super IO Configuration	30
4.2.2.3 Hardware Monitor	31
4.2.2.4 S5 RTC Wake Settings	32
4.2.2.5 CPU Configuration	34
4.2.2.6 PPM Configuration	35
4.2.2.7 Thermal Configuration	36
4.2.2.8 IDE Configuration	37
4.2.2.9 Miscellaneous Configuration	38
4.2.2.10 CSM Configuration	39
4.2.2.11 USB Configuration	40
4.2.2.12 Security Configuration	41

4.3 Chipset Menu.....	42
4.4 Security Menu.....	43
4.5 Boot Configuration	44
4.6 Save & Exit.....	45
4.7 Using Recovery Wizard to Restore Computer	46
Chapter 5: Driver Installation	48
5.1 Installing Chipset Driver	48
5.2 Installing Graphics Driver	50
5.3 Installing Intel Sideband Fabric Device Driver	51
5.4 Installing Intel Trusted Engine Interface Driver	52
5.5 Installing Intel Network Connections.....	53
5.6 Installing Audio Driver.....	54
Chapter 6: Maintenance and Troubleshooting	55
6.1 Cleaning the Monitor.....	55
6.2 Basic Troubleshooting	55
Appendix.....	56
Appendix A: Hardware Specifications.....	56
Appendix B: Winmate Software Development Kit.....	58

Preface

FCC Statement



This device complies with part 15 FCC rules.

Operation is subject to the following two conditions:

- This device may not cause harmful interference.
- This device must accept any interference received including interference that may cause undesired operation.

This equipment has been tested and found to comply with the limits for a class "B" digital device, pursuant to part 15 of the FCC rules. These limits are designed to provide reasonable protection against harmful interference when the equipment is operated in a commercial environment. This equipment generates, uses, and can radiate radio frequency energy and, if not installed and used in accordance with the instruction manual, may cause harmful interference to radio communications. Operation of this equipment in a residential area is likely to cause harmful interference in which case the user will be required to correct the interference at his own expense.

European Union



Electromagnetic Compatibility Directive (2014/30/EU)

- EN55024: 2010/ A1: 2015
 - IEC61000-4-2: 2009
 - IEC61000-4-3: 2006+A1: 2007+A2: 2010
 - IEC61000-4-4: 2012
 - IEC61000-4-5: 2014
 - IEC61000-4-6: 2014
 - IEC61000-4-8: 2010
 - IEC61000-4-11: 2004
- EN55032: 2012/AC:2013
- EN61000-3-2:2014
- EN61000-3-3:2013

Low Voltage Directive (2014/35/EU)

- EN 60950-1:2006/A11:2009/A1:2010/A12:2011/ A2:2013

This equipment is in conformity with the requirement of the following EU legislations and harmonized standards. Product also complies with the Council directions.

Copyright Notice

No part of this document may be reproduced, copied, translated, or transmitted in any form or by any means, electronic or mechanical, for any purpose, without the prior written permission of the original manufacturer.

Trademark Acknowledgement

Brand and product names are trademarks or registered trademarks of their respective owners.

Disclaimer

Winmate Inc. reserve the right to make changes, without notice, to any product, including circuits and/or software described or contained in this manual in order to improve design and/or performance. We assume no responsibility or liability for the use of the described product(s) conveys no license or title under any patent, copyright, or masks work rights to these products, and make no representations or warranties that these products are free from patent, copyright, or mask work right infringement, unless otherwise specified. Applications that are described in this manual are for illustration purposes only. We make no representation or guarantee that such application will be suitable for the specified use without further testing or modification.

Warranty

Winmate Inc. warranty guarantees that each of its products will be free from material and workmanship defects for a period of one year from the invoice date. If the customer discovers a defect, we will, at his/her option, repair or replace the defective product at no charge to the customer, provide it is returned during the warranty period of one year, with transportation charges prepaid. The returned product must be properly packaged in its original packaging to obtain warranty service. If the serial number and the product shipping data differ by over 30 days, the in-warranty service will be made according to the shipping date. In the serial numbers the third and fourth two digits give the year of manufacture, and the fifth digit means the month (e. g., with A for October, B for November and C for December).

For example, the serial number 1W19Axxxxxxx means October of year 2019.

Customer Service

We provide a service guide for any problem by the following steps: First, visit the website of our distributor to find the update information about the product. Second, contact with your distributor, sales representative, or our customer service center for technical support if you need additional assistance.

You may need the following information ready before you call:

- Product serial number
- Software (OS, version, application software, etc.)
- Description of complete problem
- The exact wording of any error messages

In addition, free technical support is available from our engineers every business day. We are always ready to give advice on application requirements or specific information on the installation and operation of any of our products.

Advisory Conventions

Four types of advisories are used throughout the user manual to provide helpful information or to alert you to the potential for hardware damage or personal injury. These are Notes, Important, Cautions, and Warnings. The following is an example of each type of advisory.



Note:

A note is used to emphasize helpful information



Important:

An important note indicates information that is important for you to know.



Caution A Caution alert indicates potential damage to hardware and explains how to avoid the potential problem.

Attention Une alerte d'attention indique un dommage possible à l'équipement et explique comment éviter le problème potentiel.



Warning! An Electrical Shock Warning indicates the potential harm from electrical hazards and how to avoid the potential problem.

Avertissement! Un Avertissement de Choc Électrique indique le potentiel de chocs sur des emplacements électriques et comment éviter ces problèmes.



Alternating Current ! The Protective Conductor Terminal (Earth Ground) symbol indicates the potential risk of serious electrical shock due to improper grounding.

Mise à le terre ! Le symbole de Mise à Terre indique le risqué potentiel de choc électrique grave à la terre incorrecte.

Safety Information

Warning! Always completely disconnect the power cord from your chassis whenever you work with the hardware. Do not make connections while the power is on. Sensitive electronic components can be damaged by sudden power surges. Only experienced electronics personnel should open the PC chassis.



Avertissement ! Toujours débrancher le cordon d'alimentation du chassis lorsque vous travaillez sur celui-ci. Ne pas brancher de connections lorsque l'alimentation est présente. Des composantes électroniques sensibles peuvent être endommagées par des sauts d'alimentation. Seulement du personnel expérimenté devrait ouvrir ces chassis.

Caution Always ground yourself to remove any static charge before touching the CPU card. Modern electronic devices are very sensitive to static electric charges. As a safety precaution, use a grounding wrist strap at all times. Place all electronic components in a static-dissipative surface or static-shielded bag when they are not in the chassis.



Attention Toujours verifier votre mise à la terre afin d'éliminer toute charge statique avant de toucher la carte CPU. Les équipements électroniques modernes sont très sensibles aux décharges d'électricité statique. Toujours utiliser un bracelet de mise à la terre comme précaution. Placer toutes les composantes électroniques sur une surface conçue pour dissiper les charge, ou dans un sac anti-statique lorsqu'elles ne sont pas dans le chassis.

About This User Manual

This User Manual provides information about using the Winmate® IP65 Stainless B Series Panel PC with Push Buttons powered by Intel® Celeron® N2930 (2M Cache, up to 2.16 GHz) processor. The documentation set includes:

- **User Manual** – contains detailed description on how to use the Panel PC, its components and features.
- **Quick Start Guide** - contains detailed description on how to use the Panel PC, its components and features.



Note:

Some pictures in this guide are samples and can differ from actual product.

Chapter 1: Introduction

1.1 Overview

Congratulations on purchasing Winmate® IP65 Stainless B Series Panel PC.

Winmate B Series Display features SUS 316/ AISI 316 stainless steel corrosion resistant housing and big mechanical push buttons on the front. Push-buttons bring control and indication directly to the work area, eliminating wasted movement and increasing productivity. In addition, the physical buttons are especially needed for critical tasks like emergency shutdowns. When an emergency situation occurs, we don't want to waste time navigating through HMI screens but a simple and quick way to shut down the process. In terms of machine integration, push-button devices are easy to install and wire, and straightforward for understanding the function and use. Averagely the wiring time is saved by over 60%, and the installation cost is reduced by more than 30%.

1.2 Features

The IP65 Stainless B Series Panel PC features:

- 10.1"/ 15/ 19/ 21.5" LCD with projected capacitive multitouch screen
- Intel® Celeron® N2930 (2M Cache, up to 2.16 GHz)
- Fanless cooling system
- SUS 316/ AISI 316 stainless steel for food and chemical industries
- Full IP65 waterproof enclosure, good corrosion resistance
- A true flat, easy-to-clean front surface with edge-to-edge design
- Supports VESA mount
- Rotary switch adjust different touch mode for Hand/Rain/Glove application
- Optional Wi-Fi
- Emergency and flat buttons for automation device control

1.3 Package Content

Carefully remove the box and unpack your device. Please check if all the items listed below are inside your package. If any of these items are missing or damaged contact us immediately.

Default:



Panel PC

Varies by product specifications



Quick Start Guide (Hardcopy)

Part No. 91521110105S



Driver CD

Part No. 91711111103M

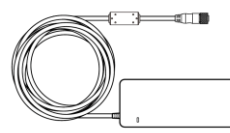

AC to DC Adapter 100~240V/ 50W with Waterproof Connector

50W Part No. 90PO12050006 (For 10.1"), 84W Part No. 90PO12084000 (15" up)

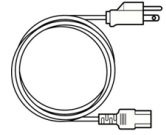

Power Cord

Varies by country

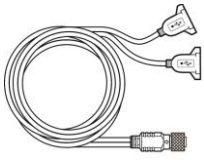

External USB Cable with Waterproof Connector

Part No. 9480128080K0

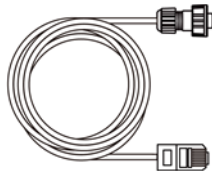

External LAN Cable with Waterproof Connector

Part No. 9410080080KF

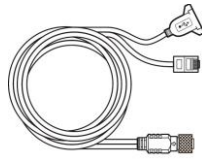

External USB & LAN Cable with Waterproof Connector

Part No. 94E0128040K0 (for 10.1")

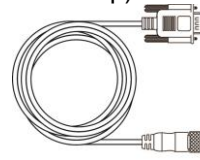

External COM Cable with Waterproof Connector

Part No. 94G0123090Q0

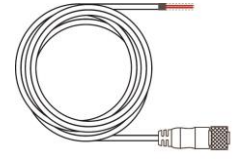

External Cables for CN1 & CN2 with Waterproof Connector

Part No. 94E012L120K1

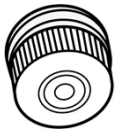

Waterproof Caps

Part No. 60Y031001001

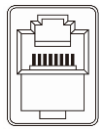

RJ45 Female to Female Converter

Part No. 60L0A8400000

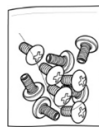

VESA Screws

Part No. 913511101101

Optional:

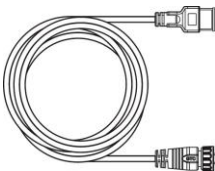

External HDMI Cable with Waterproof Connector

Part No. 9490191190K0

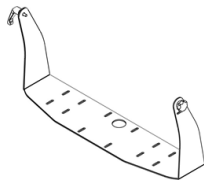

Yoke Mount Stand Kit

1.4 Product Overview

This section contains mechanical drawing of the IP65 Stainless B Series Panel PC with Push Buttons. Notice that this is a simplified drawing and some components are not marked in detail.

10.1", W10IB3S-SPH2-B

Unit: mm

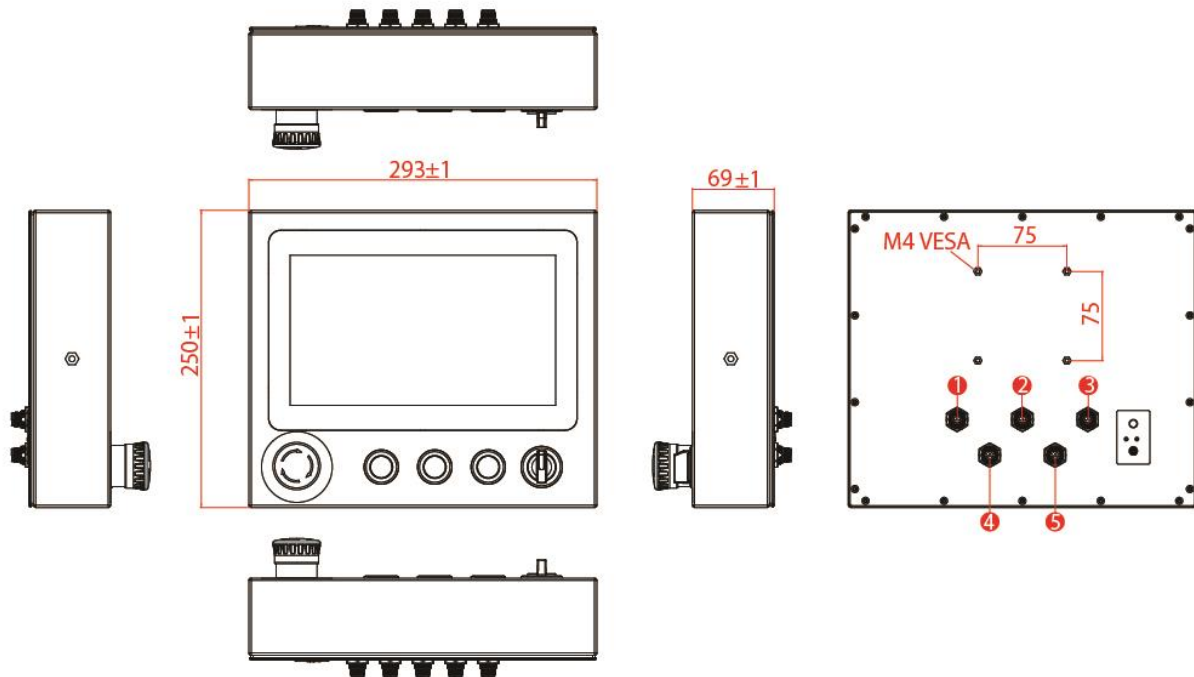

No	Description	No	Description
①	USB & LAN	④	CN1 (For Emergency Stop & Blue Button)
②	COM	⑤	CN2(For Green Button & Red Button)
③	Power		

15", R15IB3S-SPC3-B

Unit: mm

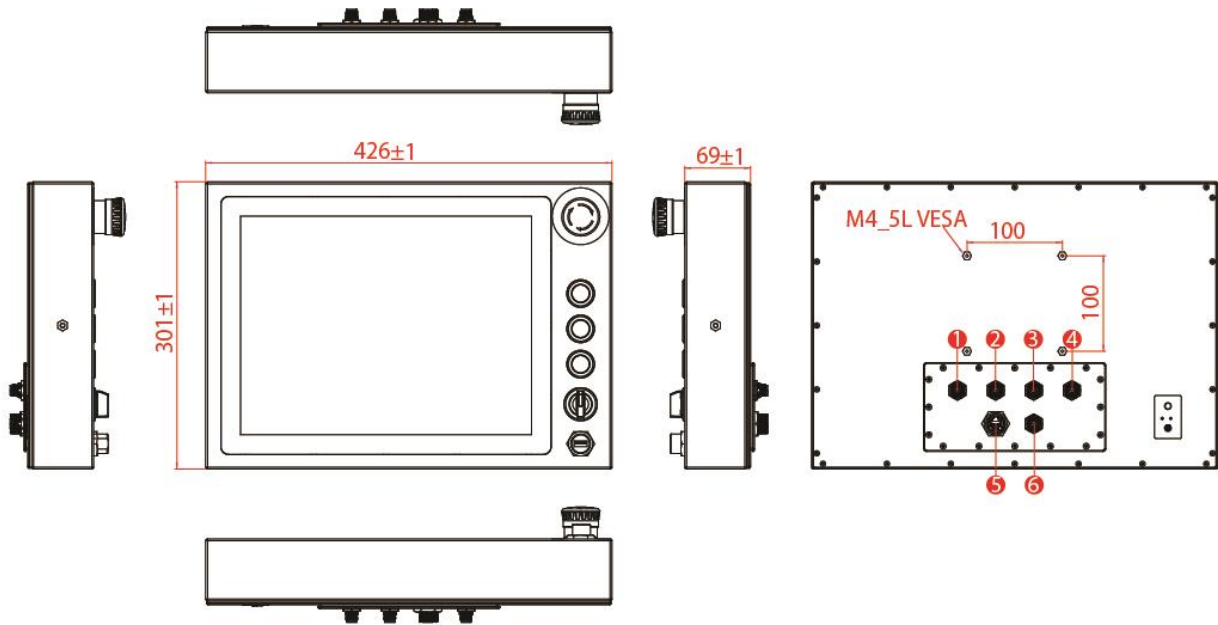

No	Description	No	Description
①	USB x 2	④	CN2(For Green Button & Red Button)
②	COM	⑤	LAN
③	CN1 (For Emergency Stop & Blue Button)	⑥	Power

19", R19IB3S-SPM1-B

Unit: mm

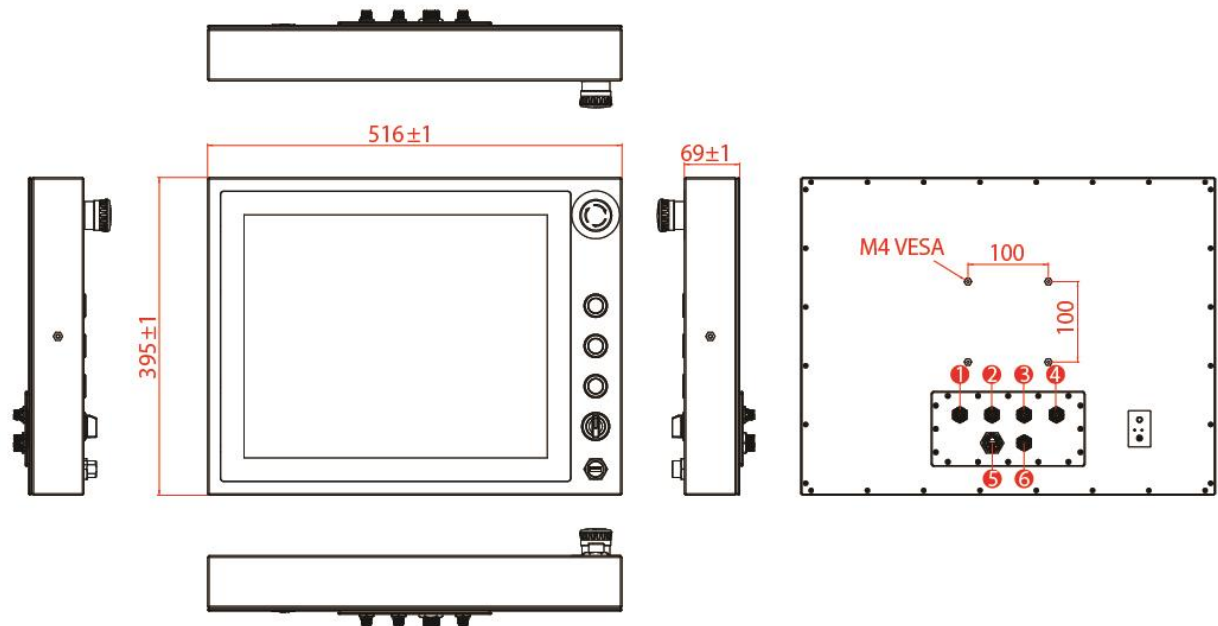

No	Description	No	Description
①	USB x 2	④	CN2(For Green Button & Red Button)
②	COM	⑤	LAN
③	CN1 (For Emergency Stop & Blue Button)	⑥	Power

21.5", W22IB3S-SPA3-B

Unit: mm

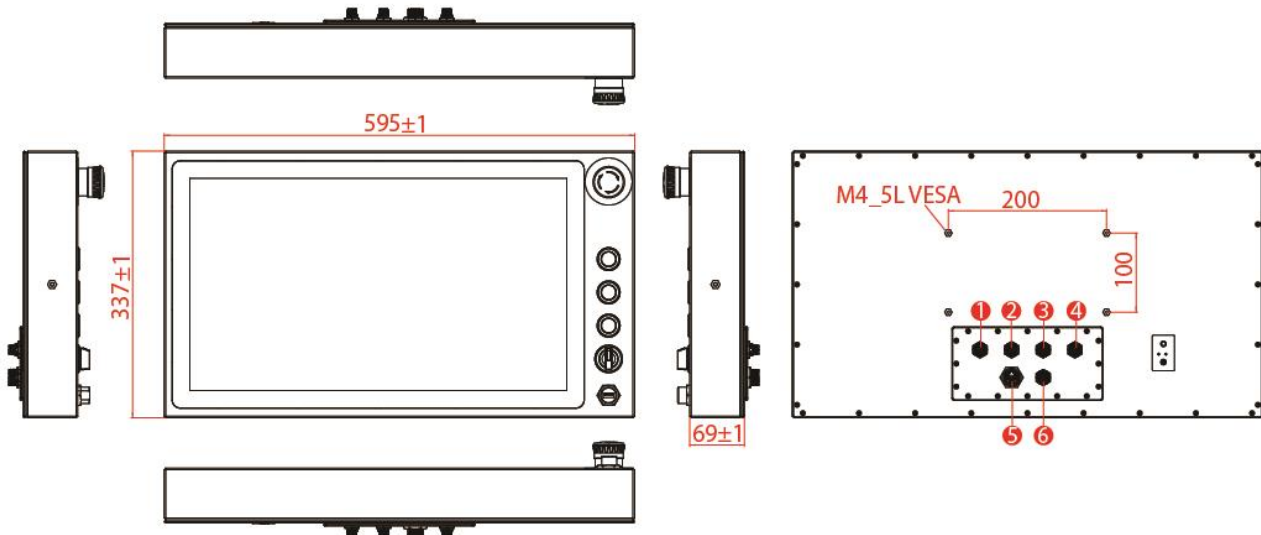

No	Description	No	Description
①	USB x 2	④	CN2(For Green Button & Red Button)
②	COM	⑤	LAN
③	CN1 (For Emergency Stop & Blue Button)	⑥	Power

1.5 Front Side USB Type-A Connector

The B Series Panel PC 15" up has one waterproof USB Type-A connector on the front side.

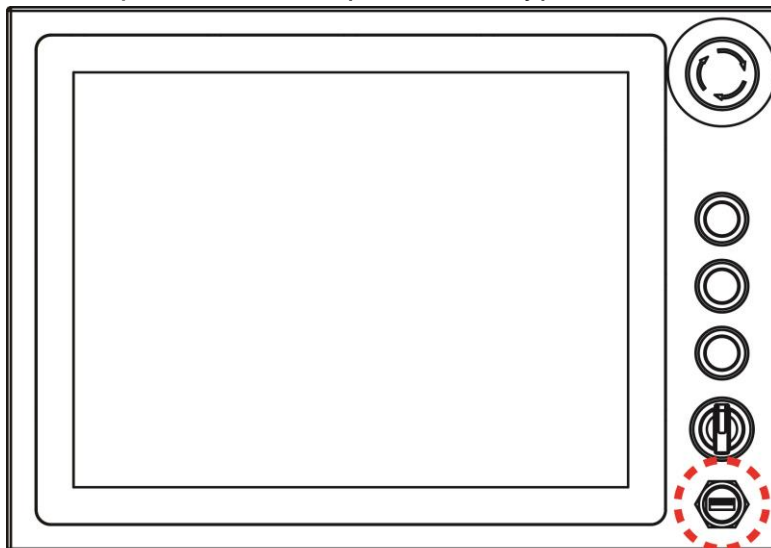

1.6 Front Side Push Buttons

The B Series Panel PC features mechanical push buttons located on the front side of the Panel PC.

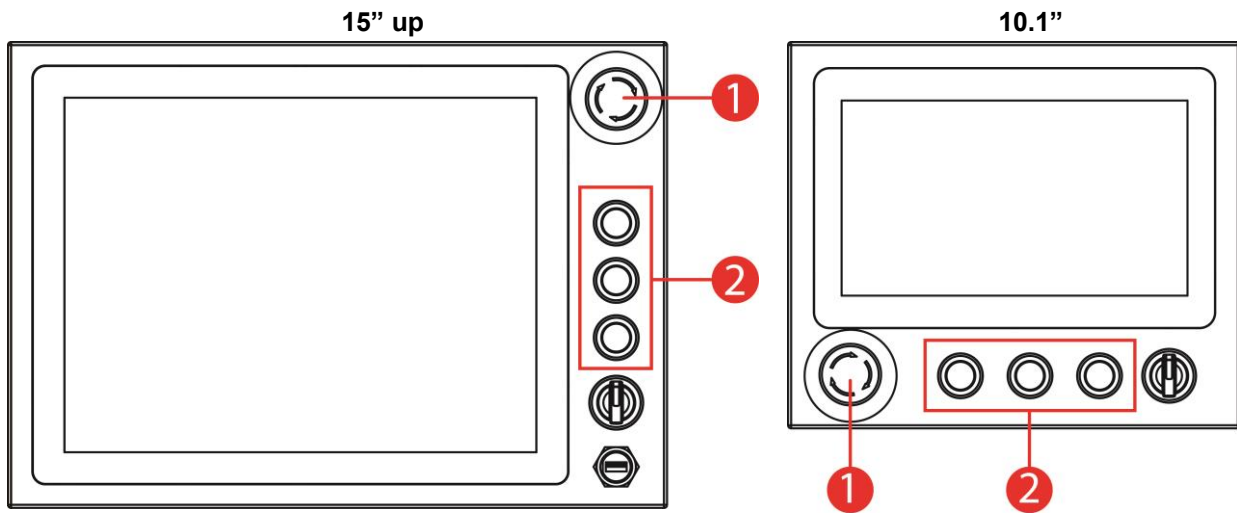



No	Button	Description
1	Emergency Shut Down	Press to shut down the system. Pressing this button stops all operations immediately (motors, valve, etc.). Emergency stop conditions shall be hard wired, withdraw power from everything.
2	Programmable Function Keys	Three programmable function keys, functions to be defined by customer.

1.7 Rotary Switch for Touch Mode

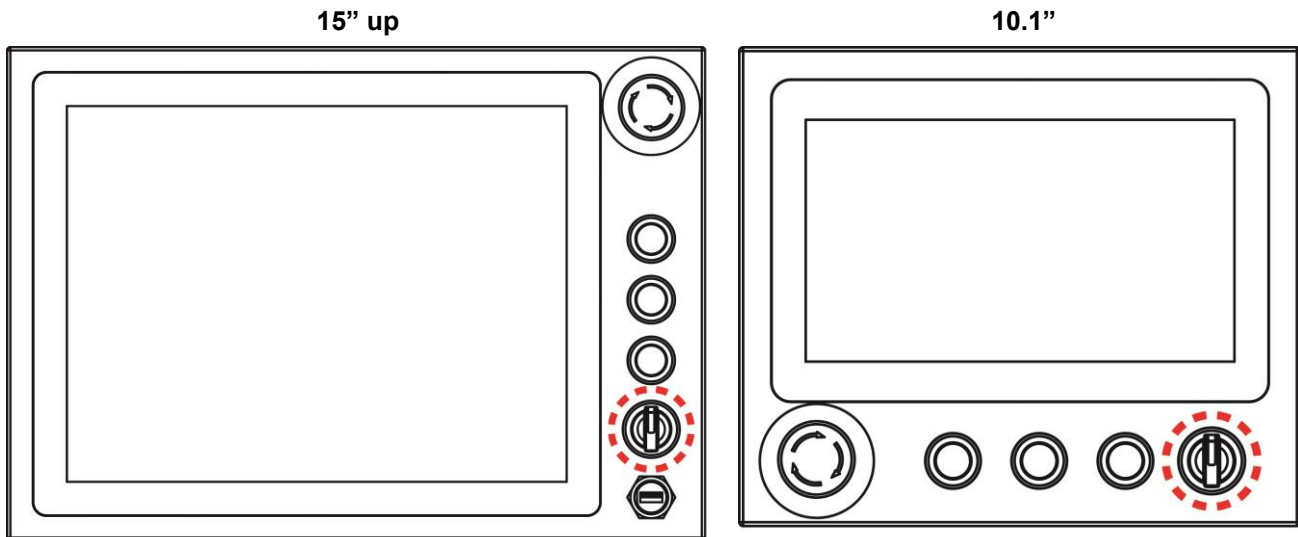
The IP65 Stainless B Series Panel PC features rotary switch for quick changing a touch mode located on the front side of the Panel PC. Use rotary switch located in front to switch between modes.





Mode	Description
 Hand (Default)	In <i>Hand</i> mode the touchscreen accepts touch inputs from bare fingertips. <i>Supports input by:</i> <ul style="list-style-type: none"> • <i>Rubber tip passive stylus</i> • <i>Bare fingertips</i>
 Rain	In <i>Rain</i> mode the touchscreen rejects false inputs from liquid drops. When the liquid is removed, the touchscreen accepts touch inputs from bare fingertips. <i>Supports input by:</i> <ul style="list-style-type: none"> • <i>Rubber tip passive stylus</i> • <i>Bare fingertips</i>
 Glove	In <i>Glove</i> mode, the touchscreen supports inputs while the user is operating the touchscreen with gloves on. <i>Supports input by:</i> <ul style="list-style-type: none"> • <i>Glove</i> • <i>Rubber tip passive stylus</i> • <i>Bare fingertips</i>

1.8 Rear Side Physical Buttons

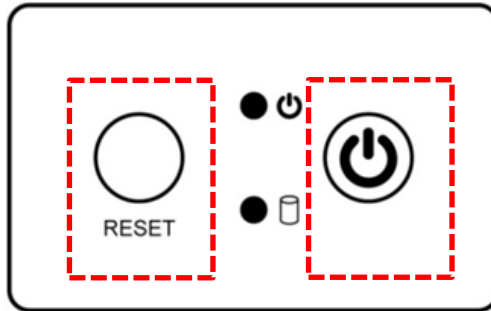
Physical buttons are located on the OSD panel at the rear side of the Panel PC.





Button	Function	Description
	Reset	Press to reset the system
	Power On/ Off	Press to power on or power off the device

1.9 LED Indicators

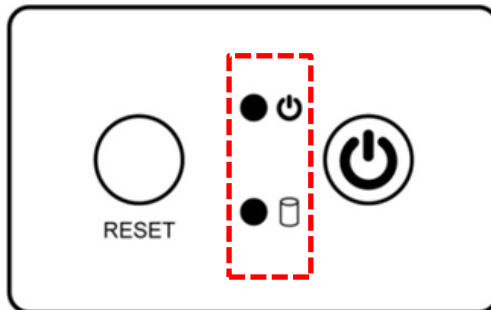
LED indicators are located on the OSD panel at the rear side of the Panel PC.



LED Indicator	Status	Description
	On	Power is on
	Off	Power is off
	Blinking	Stan by
	Off	Normal

Chapter 2: Installation

Follow this quick installation procedure:

1. Mount your Panel PC according to your application requirements (VESA, Yoke).
2. Connect all the cables to the Panel PC.
3. Use waterproof caps to cover all not used connectors.
4. To ensure enclosure rating protection make sure the cables is firmly fixed and tightened.



Caution Use waterproof cables to ensure the IP65 rating.

Attention. Utilisez des câbles étanches pour garantir l'indice IP65.



Caution When not in use, cover connector with waterproof cap.

Attention Lorsqu'il n'est pas utilisé, couvrez le connecteur avec un capuchon étanche.

2.1 Mounting

The IP65 Stainless B Series Panel PC devices come with different mounting options suitable for most of the industrial and commercial applications.

2.1.1 VESA Mount

The Panel PC has VESA mount holes on the rear side. Follow instructions below to mount the unit with VESA Mount bracket (not supplied by Winmate).

Size	VESA Plate Dimensions	Screw Hole Diameter
10.1"	75 x 75 mm	VESA M4x5 mm
15", 19"	100 x 100 mm	VESA M4x5 mm
21.5"	200 x 100 mm	VESA M4x5 mm

Installation Instruction

1. Screw VESA bracket to the fixture (ex. swing arm) with four VESA screws.
2. Place the device on VESA bracket.

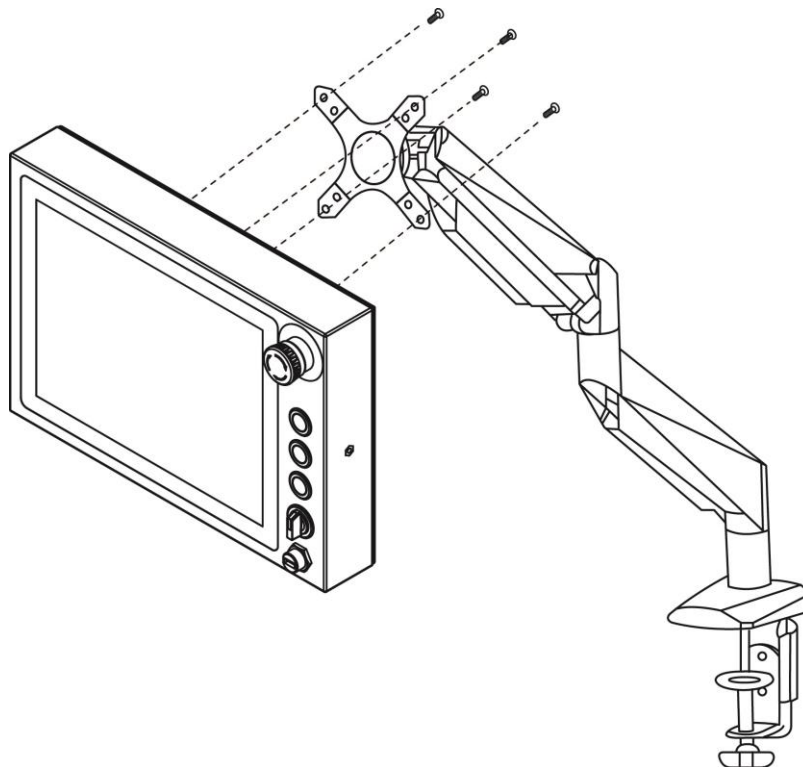

2.1.2 Yoke Mount

Yoke Mount solution allows installing the Panel PC on the yoke stand (not supplied by Winmate).

Installation Instruction

1. Place the Panel PC on the bracket stand, aiming screw holes for each other.
2. Secure screws to fix the device upon the bracket stand.
3. Firmly secure the locking handle to the Panel PC.

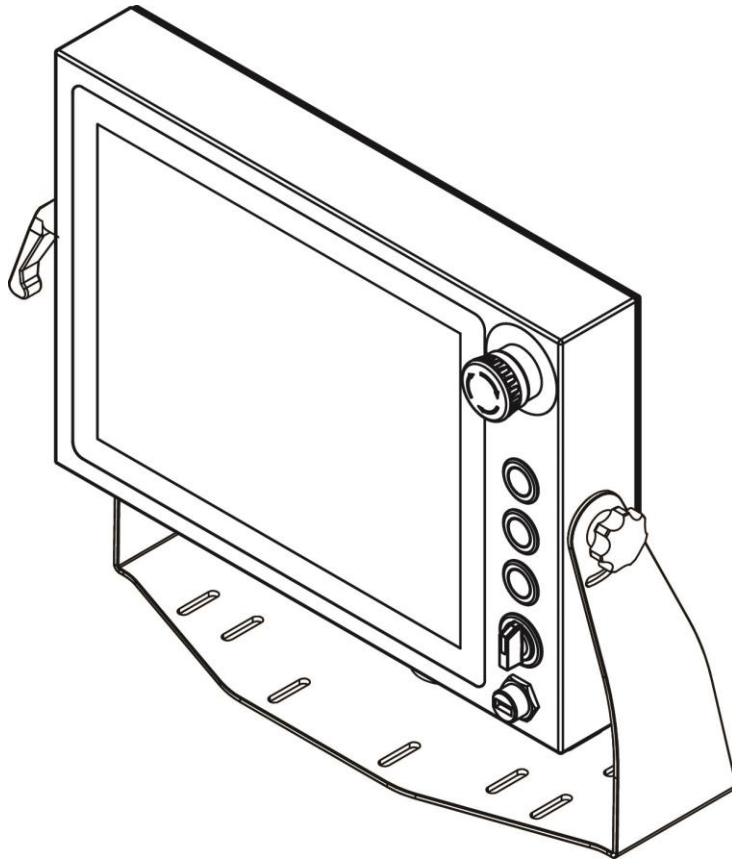

2.2 Connecting Peripherals

This B Series Panel PC has waterproof connectors with protection caps: M12 power connector, M12 GigaLAN connector, M12 RS232 connector, M12 USB connector, two M12 connectors for push button extension and one waterproof connector USB2.0 type-A (15" up). The pin assignment of the connectors is described in this section.



Important: To maintain the IP65 rating of the full unit it is recommended to use only IP65 waterproof cables. You must remember to firmly close all protective caps when connector is not used.



Note: Notice that input and output connectors vary by product size and specifications.

2.2.1 Power Connector

By default the B Series Panel PC has one M12 waterproof power connector that accepts 12V DC power input based on your order.

Power Cable

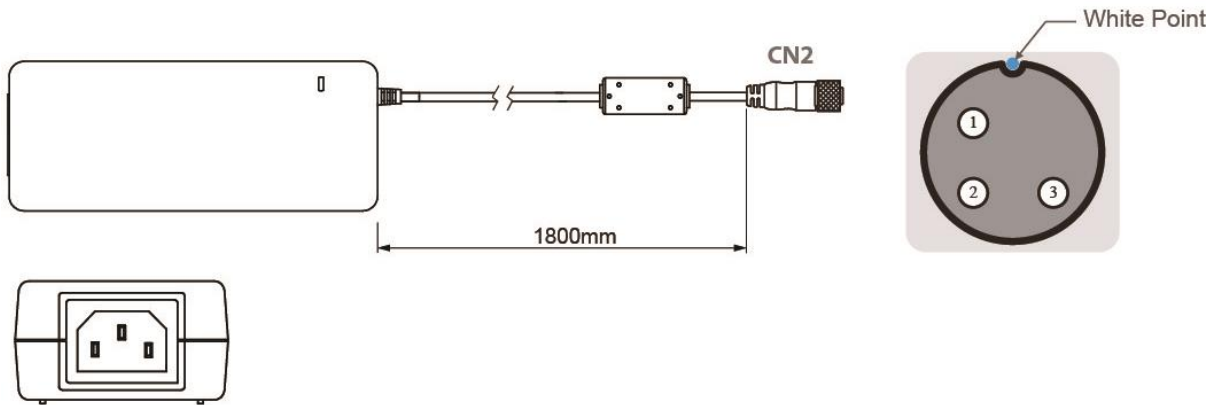

Pin No.	Symbols	Color		Pin No.	Symbols	Color
CN1-1	VIN -	NO ASSIGN	↔	CN2-1	VCC+	Flow Adapter
CN1-2	VIN -	NO ASSIGN	↔	CN2-2	GND	Flow Adapter
CN1-3	VIN -	NO ASSIGN	↔	CN2-3	VCC -	Flow Adapter

2.2.2 LAN Connector

The B Series Panel PC has one M12 connector for GigaLAN. Use waterproof LAN cable to connect the Panel PC to the Internet.

LAN Cable

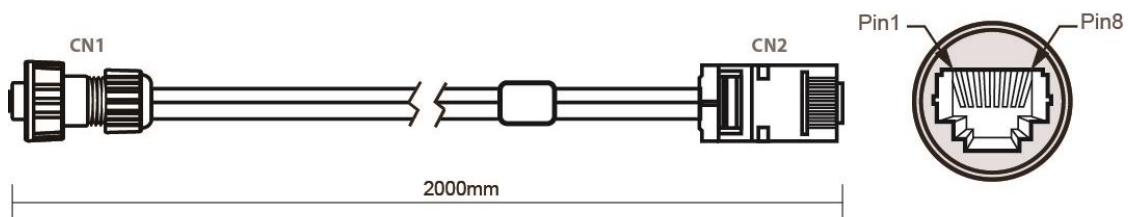

Plug	Wire Color	Conn.	
1	Orange / White	1	Twist
2	Orange	2	
3	Green / White	3	Twist
4	Blue	4	
5	Blue / White	5	Twist
6	Green	6	
7	Brown / White	7	Twist
8	Brown	8	

2.2.3 USB Connector

The B Series Panel PC has one M12 waterproof connector for touch screen control. Use waterproof USB cable to connect Panel PC to external peripherals such as mouse or keyboard.

USB Cable

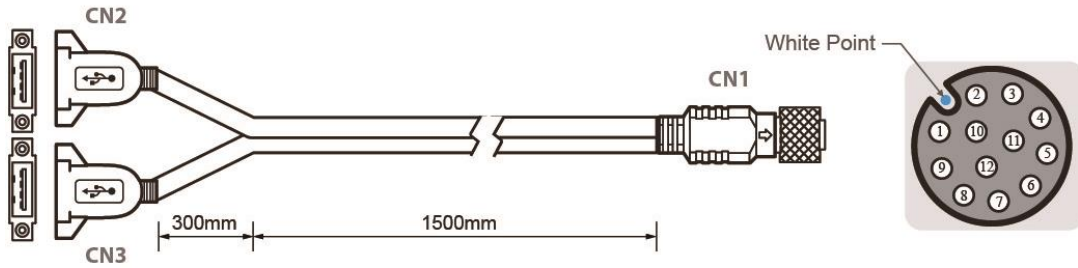

Pin No.	Symbols	Color		Pin No.	Symbols	Color	
CN1-2	VCC	RED	↔	CN2-1	VCC	RED	twisted pair
CN1-3	D-	WHITE	↔	CN2-2	D-	WHITE	
CN1-4	D+	GREEN	↔	CN2-3	D+	GREEN	
CN1-5	GND	BLACK	↔	CN2-4	GND	BLACK	
CN1-6	VCC	RED	↔	CN3-1	VCC	RED	twisted pair
CN1-7	D-	WHITE	↔	CN3-2	D-	WHITE	
CN1-8	D+	GREEN	↔	CN3-3	D+	GREEN	
CN1-9	GND	BLACK	↔	CN3-4	GND	BLACK	
CN1-1	GND	Braid	↔	Braid connect to the housing			

2.2.4 USB Type-A Connector

The B Series Panel PC 15"/ 19"/ 21.5" has one waterproof USB Type-A connector located on the front side.

Pin assignment and signal name of USB 2.0 connector for optional touch.



Pin №	Signal Name	Pin №	Signal Name
1	+5V	2	Data-
3	Data+	4	GND

2.2.5 RS-232 Connector

The B Series Panel PC has one M12 connector for RS-232. Use waterproof USB cable to connect Panel PC to external peripherals such as printer or keyboard.

RS-232 Cable

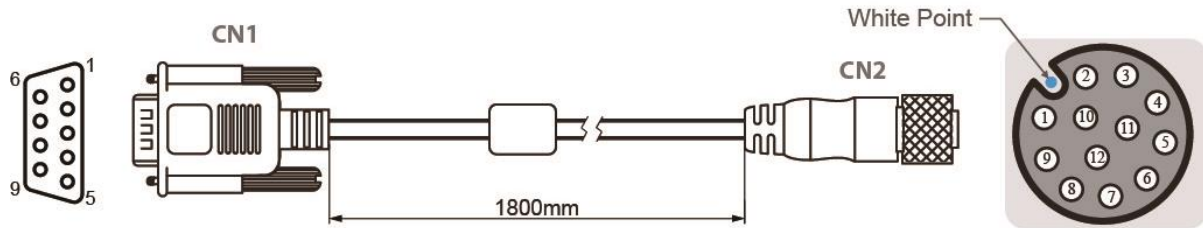

Pin No.	Symbols	Color		Pin No.	Symbols	Color
CN1-1	DCD-CON2	Green	↔	CN2-1	DCD-CON2	Green
CN1-6	DSR-CON2	Brown	↔	CN2-2	DSR-CON2	Brown
CN1-2	RXD-CON2	Red	↔	CN2-3	RXD-CON2	Red
CN1-7	RTS-CON2	Orange	↔	CN2-4	RTS-CON2	Orange
CN1-3	TXD-CON2	Blue	↔	CN2-5	TXD-CON2	Blue
CN1-8	CTS-CON2	White	↔	CN2-6	CTS-CON2	White
CN1-4	DTR-CON2	Purple	↔	CN2-7	DTR-CON2	Purple
CN1-9	RI-CON2	Yellow	↔	CN2-8	RI-CON2	Yellow
CN1-5	GND-CON2	Black	↔	CN2-9	GND-CON2	Black

2.2.6 Connector 1 for Push Button Extension

Push Button Extension Cable for Connector 1

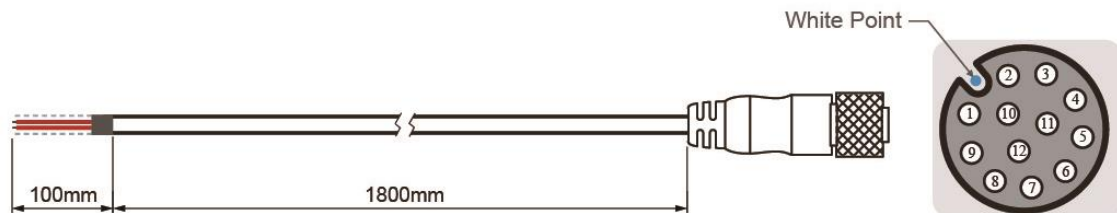

Pin No.	Symbols	Color
CN1-1	Emergency NC 2	Emergency Stop
CN1-2	Emergency NC 1	
CN1-3	Emergency NC 2	
CN1-4	Emergency NC 1	
CN1-5	Blue NO 4	Blue Button
CN1-6	Blue NO 3	
CN1-7	Blue NC 2	
CN1-8	Blue NC 1	
CN1-9	N/A	
CN1-10	N/A	
CN1-11	N/A	
CN1-12	N/A	

2.2.7 Connector 2 for Push Button Extension

Push Button Extension Cable for Connector 2

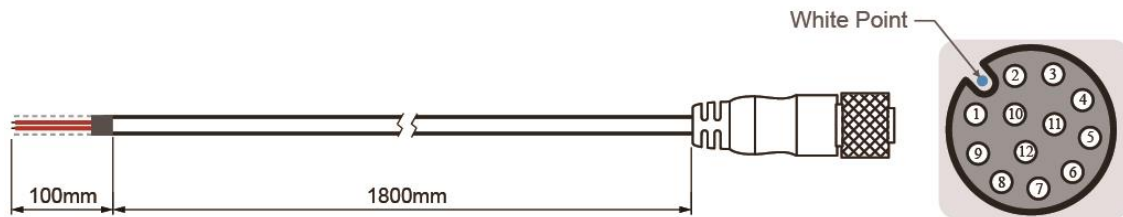

Pin No.	Symbols	Color
CN2-1	Red NO 4	Green Button
CN2-2	Red NO 3	
CN2-3	Red NC 2	
CN2-4	Red NC 1	
CN2-5	Green NO 4	Red Button
CN2-6	Green NO 3	
CN2-7	Green NC 2	
CN2-8	Green NC 1	
CN2-9	N/A	
CN2-10	N/A	
CN2-11	N/A	
CN2-12	N/A	

2.3 Cleaning the Monitor



Note: The IP65 Stainless Panel PC withstands regular intense cleaning with water.

Before cleaning:

- Make sure the device is turned off.
- Disconnect the power cable from any AC outlet.

When cleaning:

- Wipe the screen with a clean, soft, lint-free cloth. This removes dust and other particles.
- The display area is highly prone to scratching. Do not use ketene type material (ex. Acetone), Ethyl alcohol, toluene, ethyl acid or Methyl chloride to clear the panel. It may permanently damage the panel and void the warranty.
- If it is still not clean enough, apply a small amount of non-ammonia, non-alcohol based glass cleaner onto a clean, soft, lint-free cloth, and wipe the screen.
- Don not use oil directly on the display screen. If droplets are allowed to drop on the screen, permanent staining or discoloration may occur.

Chapter 3: Operating the Device

3.1 Connecting to Power Source

By default B Series Display has one M12 waterproof power connector that accepts 12V DC power input. Check your order specifications before connecting to power source.

Follow the following steps to connect your device to AC power source:

1. Install conduit pipe and I/O cover following the procedure described in the previous sections.

2. Connect open wires to AC adapter.
3. Connect the power cord to AC adapter.
4. Plug the power cord to the AC outlet.

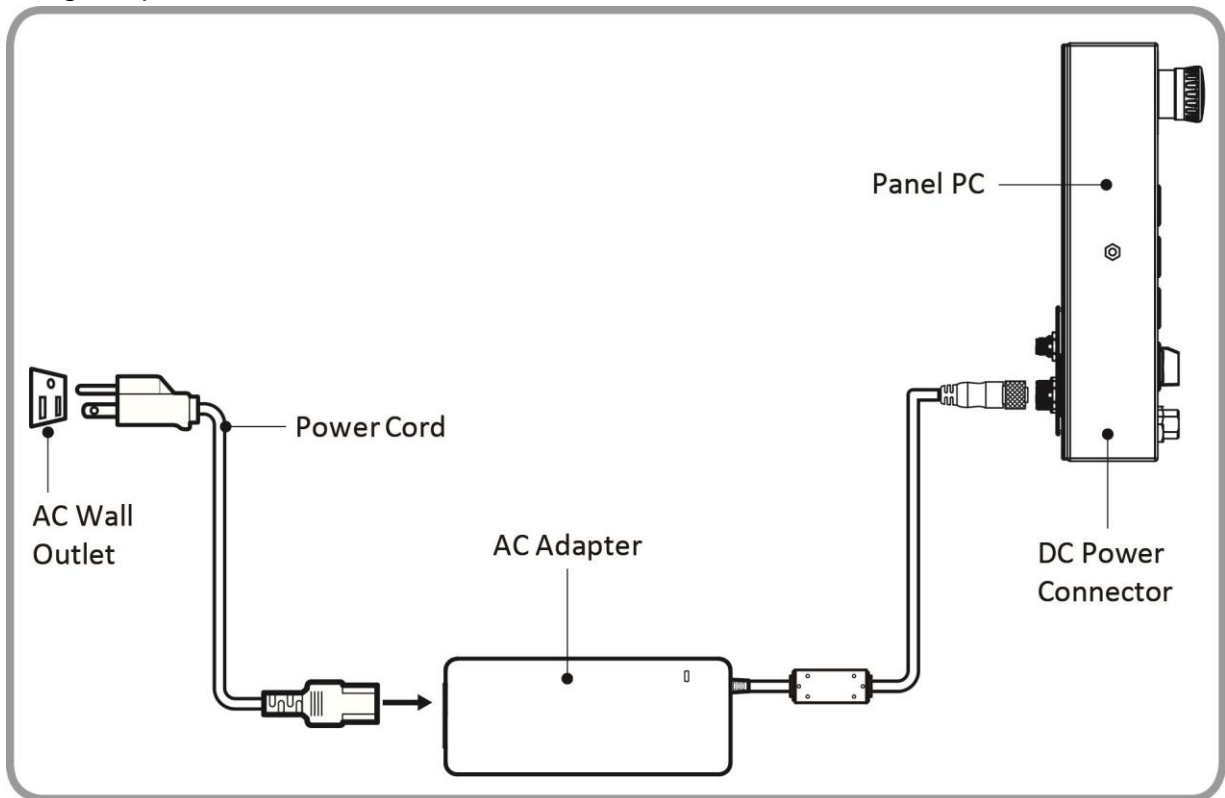

AC Adapter specifications and Panel PC power consumption vary by LCD panel size.

Size	10.1"	15"	19"	21.5"
AC Adapter	12V/ 50W	12V/ 84W	12V/ 84W	12V/ 84W
Power Consumption	26W (typ.)	30W (typ.)	36W (typ.)	50W (typ.)

3.2 Turning On/ Off the Device

After connecting your devices to the source of power press **Power Button** located on the front side of the Panel PC.

To shut down your device press **Power Button** located on the front side of the Panel PC and disconnect power. The machine operations stop in sequence, or stop in zero position to be ready to start again immediately on pressing start button.

3.3 Emergency Stop

For emergency stop, press **Emergency Shutdown Button** located on the front side of the Panel PC. Pressing this button stops all operations immediately (motors, valve, etc.). Emergency stop conditions shall be hard wired, withdraw power from everything.

15" up

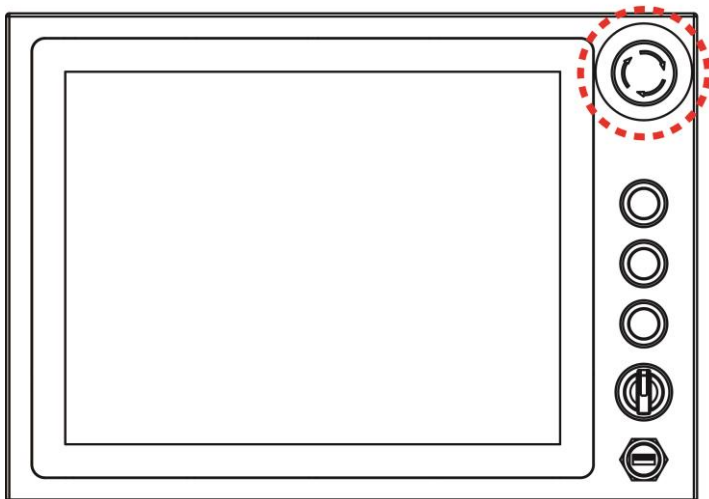

10.1"

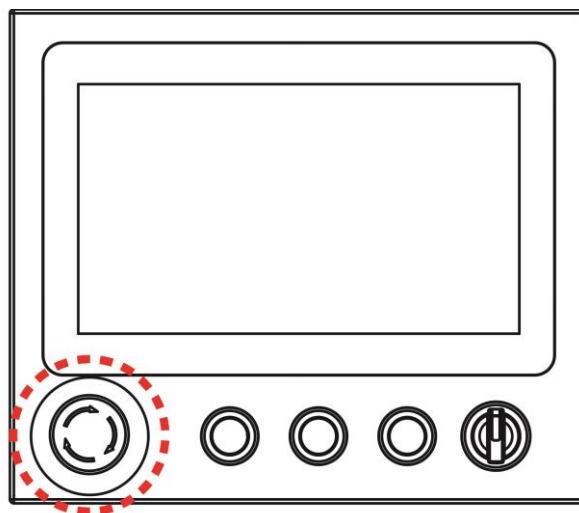

3.4 Operating System







IP65 Stainless B Series Panel PC supports Windows 10 IoT Enterprise.

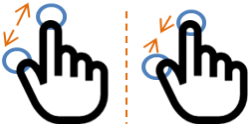

Important The device is shipped with the OS System according to your order. Contact us if you have any questions regarding OS settings.

3.5 Multi-Touch



The LCD screen features PCAP touch that supports the core gestures for Windows.

Gesture	Windows Usage	Gesture Action	Action
Tap/ Double-tap	Click / Double-click	Click or double-click	
Panning with Inertia	Scrolling	Drag one or two fingers up and down	
Selection/D rag (left to right with one finger)	Mouse-drag/ Selection	Drag one finger left/right	
Zoom	Zoom (default to CTRL key + scroll wheel)	Move two fingers apart/ toward each other	
Rotate	No system default unless handled by Application (using WM_Gesture API)	Move two fingers in opposite directions or Use one finger to pivot around another	
Press and Hold	Right-click	Press, wait for blue-ring animation to complete, then release	
Flicks	Default: Pan Up/ Down/ Back, and Forward	Make quick drag gestures in the described direction	

*Reference from Microsoft®

3.6 How to Enable Watchdog

To enable watchdog in Watchdog AP follow the instructions below:

1. On the right bottom side of the desktop screen, click  **triangle button** to show hidden icons.
2. Click  icon to open Watchdog utility.

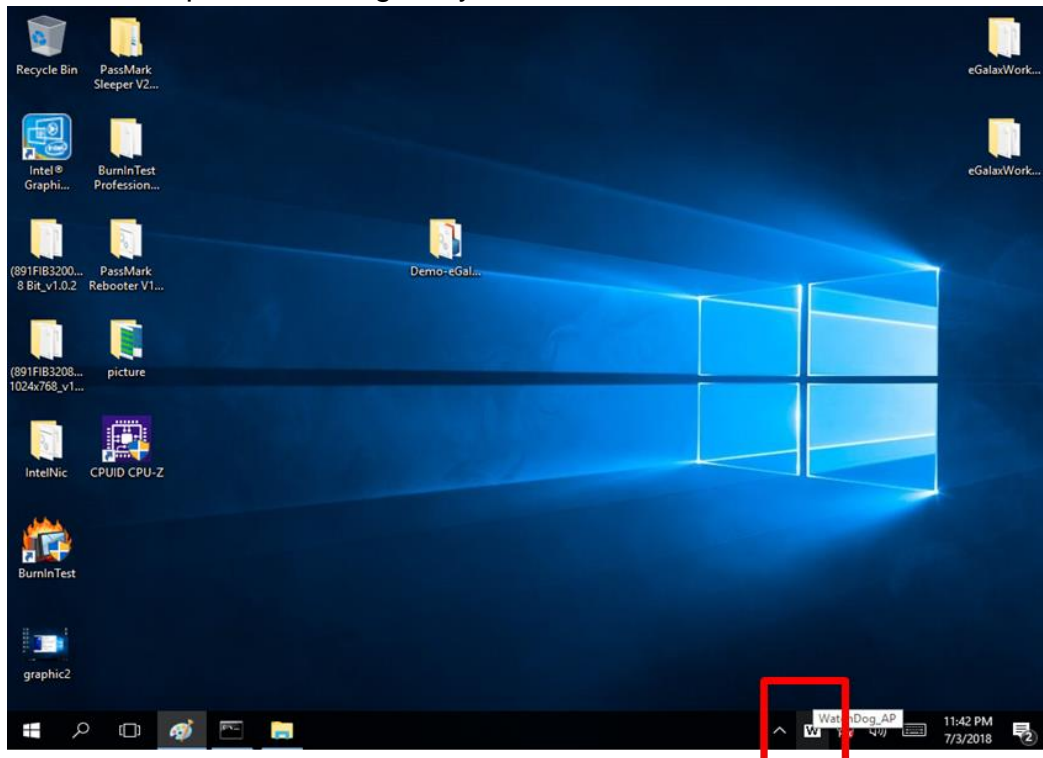

3. In Watchdog utility window set countdown time and periodically feed time, or disable watchdog.

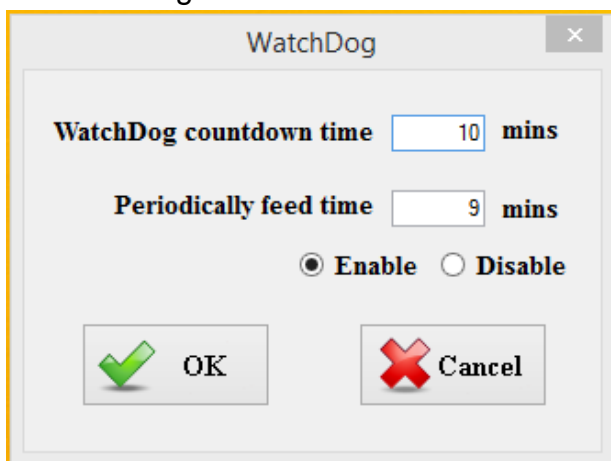

Example:

Every 10 min watchdog will monitor the system, in case any error occurs the system will restart automatically when the countdown time reaches 0. Every 9 min watchdog timer will be reset to 10 min.

Setting	Description
Watchdog Countdown Time	The system automaticity restarts when this countdown time reaches zero. <i>Default: 10 min</i>
Periodically Feed Time	To set a cycle time to automatically reset watchdog timer. <i>Default: 9 min</i>
Enable / Disable	Enable or disable watchdog. <i>Default: Enable</i>

Chapter 4: AMI BIOS Setup

To enter the BIOS setup, you need to connect an external USB keyboard, external monitor and press **Del** key when the prompt appears on the screen during start up. The prompt screen shows only few seconds so need press Del key quickly.



Important Updated BIOS version may be published after the manual released. Check the latest version of BIOS on the website.

You may need to run BIOS setup utility for reasons listed below:

1. Error message on screen indicates to check BIOS setup
2. Restoring the factory default settings.
3. Modifying the specific hardware specifications
4. Necessity to optimize specifications

BIOS Navigation Keys

The following keys are enabled during POST:

Key	Function
Del	Enters the BIOS setup menu.
F7	Display the boot menu. Lists all bootable devices that are connected to the system. With cursor ↑ and cursor ↓ and by pressing <ENTER>, select the device used for the boot.
Pause	Pressing the [Pause] key stops the POST. Press any other key to resume the POST.

The following Keys can be used after entering the BIOS Setup.

Key	Function
F1	Help
F5/ F6	Change Values
F9	Setup Defaults
F10	Save & Exit
Esc	Exit
Enter	Select SubMenu
↑ / ↓	Select Item
← / →	Select Item



Note:

You can press the F1, F2, F3, F4, -/+, and Esc keys by connecting a USB keyboard to your computer.

For items marked ► press <Enter> for more options.

4.1 Main Menu

When you enter BIOS setup, the first menu that appears on the screen is the main menu. It contains the system information including BIOS version, processor RC version, system language, time, and date. Immediately after the **[DEL]** key is pressed during startup, the main BIOS setup menu appears:



BIOS Setting	Description	Setting Option	Effect
System Language	Displays the system language. [English] is set up by default.	Adjustment of the language	Set the language in other language. The language in this device is English.
System Date/Time	This is current date setting. The time is maintained by the battery when the device is turned off.	Date and time changes.	Set the date in the format [mm/dd/yyyy]; The time in the format: [hh/mm/ss]
Access Level	The current user access settings	Changes to the level of access	Administrator is set up by the default

4.2 Advanced Menu

The advanced menu also uses to set configuration of the CPU and other system devices. There are sub menus on the left frame of the screen.



Important:

Handle advanced BIOS settings page with caution. Any changes can affect the operation of your computer.

Advanced Configuration and Power Interface (ACPI) settings allow to control how the power switch operates. The power supply can be adjusted for power requirements. You can use the screen to select options of ACPI configuration. A description of the selected items will appear on the right side of the screen.

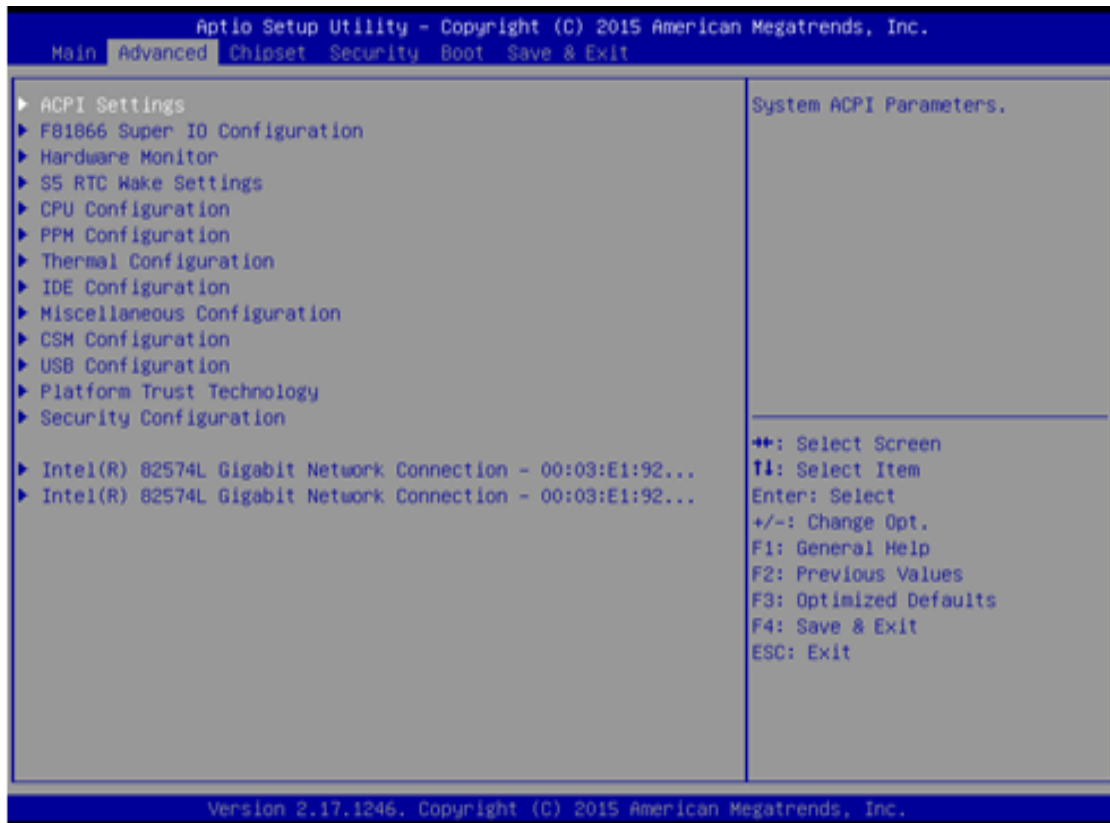

BIOS Setting	Description	Setting Option	Effect
ACPI Settings	Configures ACPI settings	Enter	Opens submenu
F81866 Super IO Configuration	Configures IO settings	Enter	Opens submenu
Hardware Monitor	Configures Hardware Monitor settings	Enter	Opens submenu
S5 RTC Wake Settings	Configures RTC Wake parameters	Enter	Opens submenu
CPU Configuration	Configures CPU settings	Enter	Opens submenu
PPM Configuration	Configures PPM settings	Enter	Opens submenu
Thermal Configuration	Configures Thermal Parameters	Enter	Opens submenu
IDE Configuration	Configures IDE Parameters	Enter	Opens submenu
Miscellaneous Configuration	Configures Miscellaneous Parameters	Enter	Opens submenu
CSM Configuration	Configures CSM Parameters	Enter	Opens submenu
USB Configuration	Configures USB Settings	Enter	Opens submenu
Platform Trust Technology	Configures Platform Trust Technology parameters	Enter	Opens submenu
Security Configuration	Configures Security parameters	Enter	Opens submenu

4.2.2.1 ACPI Settings

Advanced Configuration and Power Interface (ACPI) settings allow to control how the power switch operates. The power supply can be adjusted for power requirements. You can use the screen to select options of ACPI configuration. A description of the selected items will appear on the right side of the screen.

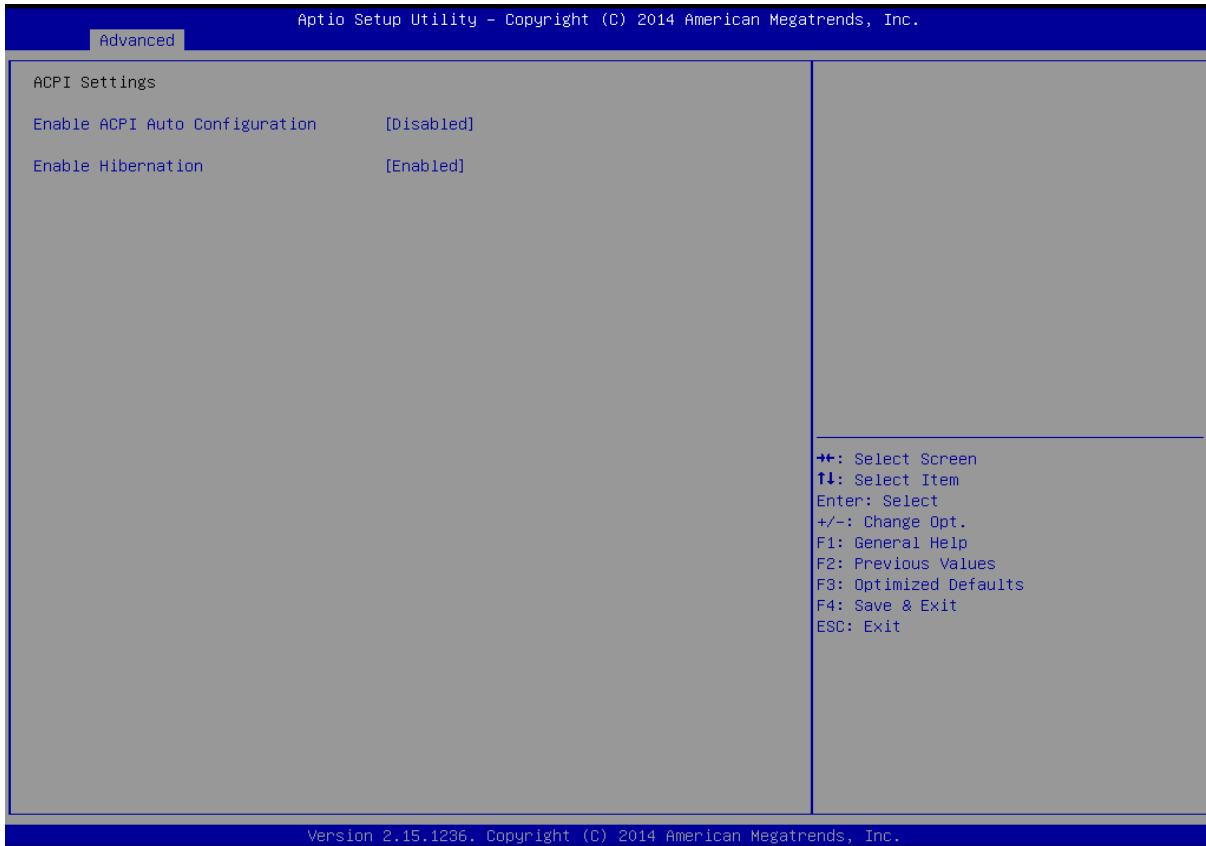

BIOS Setting	Description	Setting Option	Effect
Enable ACPI Auto Configuration	BIOS ACPI Auto Configuration	Enable/ Disable	Enables or Disables this function
Enable Hibernation	Control hibernation	Enable/ Disable	Enables or Disables this function

4.2.2.2 F81866 Super IO Configuration

You can use the screen to select options for Super IO Configuration, and change the value of the option selected. A description of the selected item appears on the right side of the screen.

Serial Port 1~5

Use these items to set parameters related to serial port 1~5.

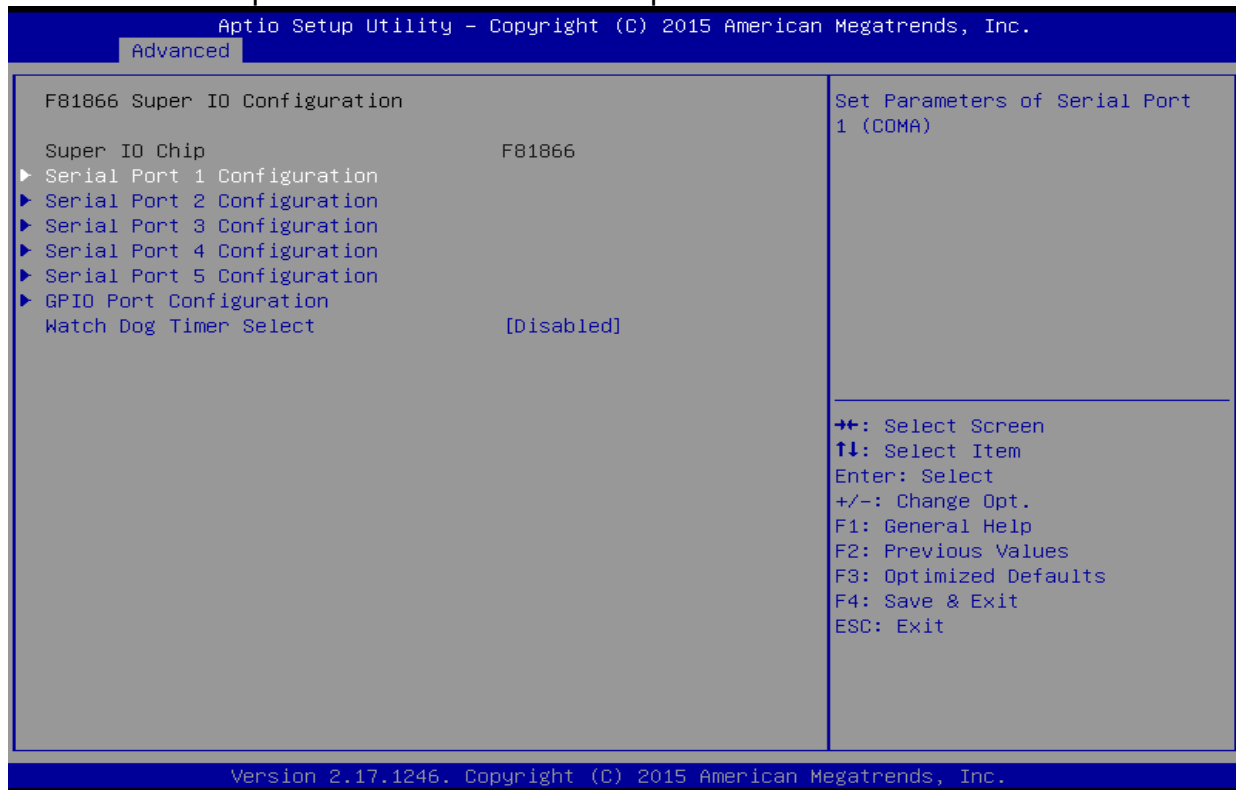

Watch Dog Time Select

You can either disable **Watch Dog Time Select**, or set up the time. Use **<Arrow>** keys to navigate and please press **<Enter>** to select the item.

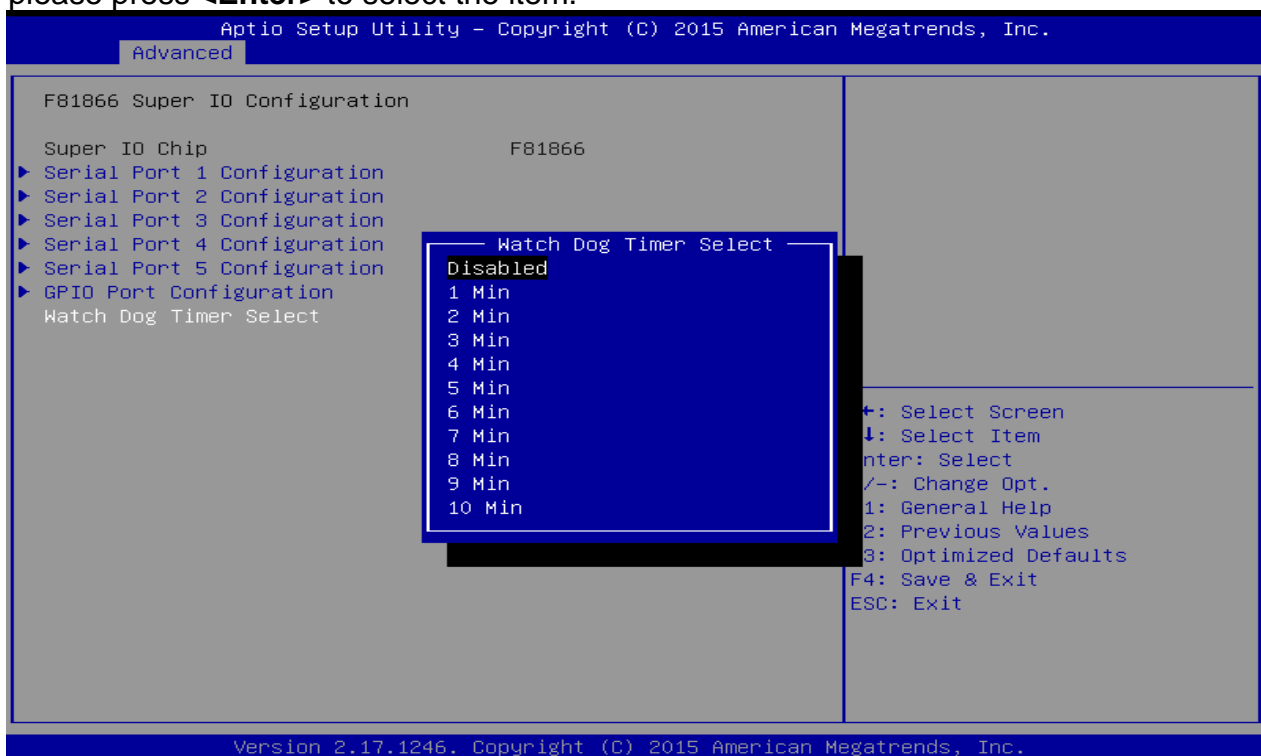

GPI0 Port Configuration

You can use the screen to change GPI0 Port setting. Use these items to set parameters related to **PIN3-PIN14 Control**.

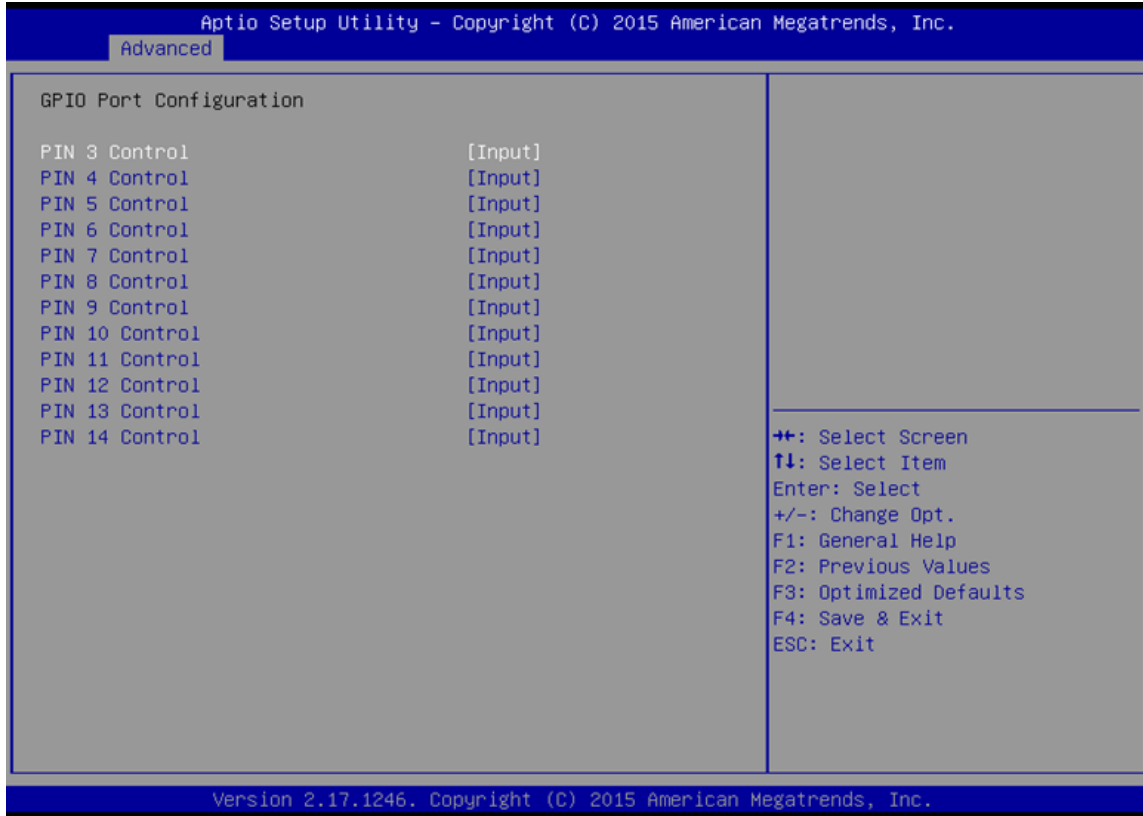

4.2.2.3 Hardware Monitor

You can check PC Health Status parameters such as system temperature, fan speed etc.

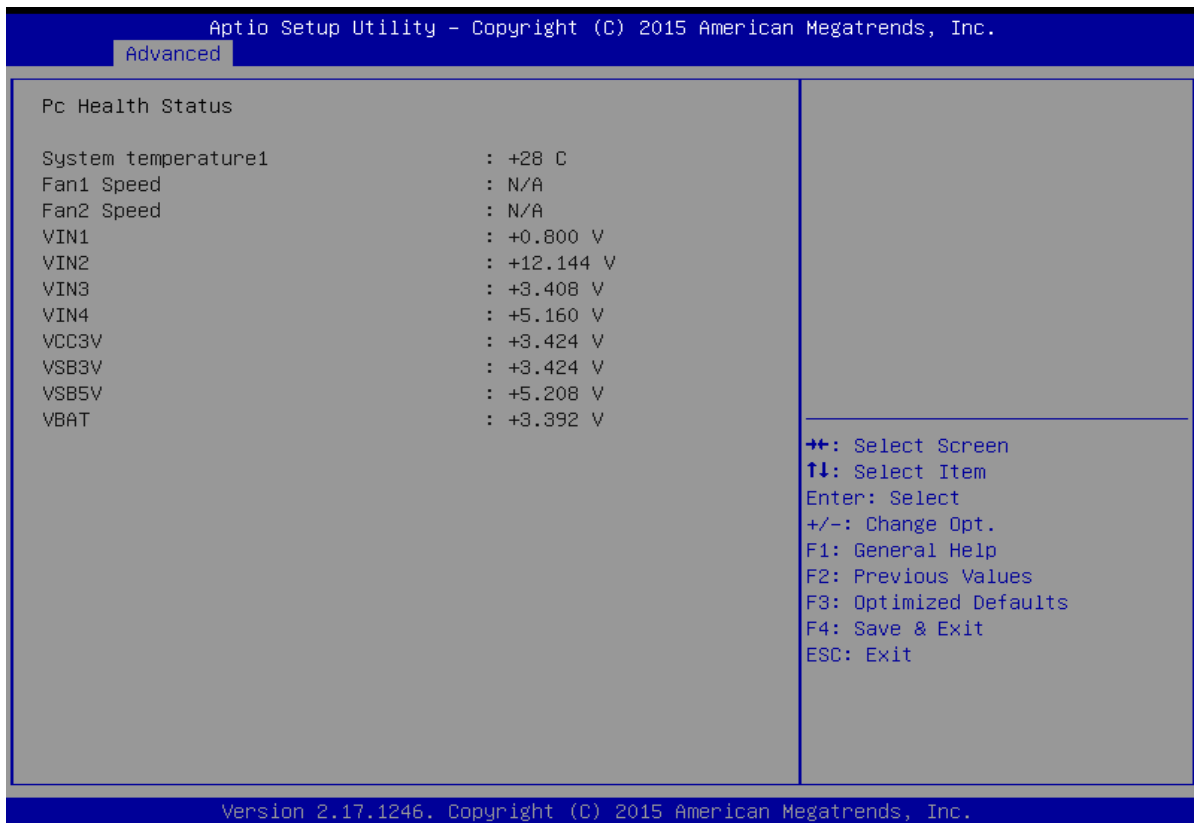



4.2.2.4 S5 RTC Wake Settings

Wake system from S5 enables or disables system wake on alarm event. It allows you to wake up the system in a certain time.



Wake System from S5 with fixed time setting

Select **Fixed Time** to set the system to wake on the specified time.

Use Navigation Keys   to switch among the items: Day, Hour, Minute and Second. Type the desired value in the selected item.

For example: If you want the system to start up automatically at 15:30:30, the 10th day of each month, then you should enter 10, 15, 30, and 30 from top to bottom.

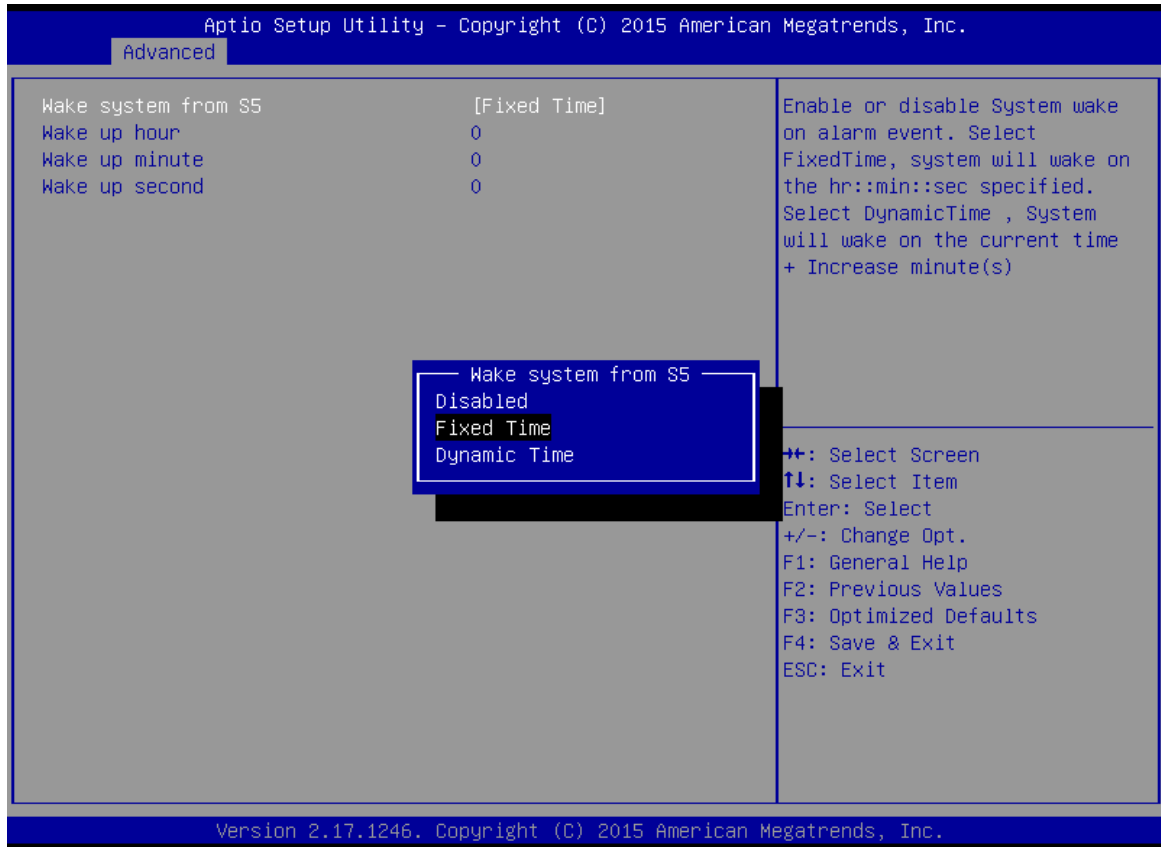

Wake system from S5 after dynamic time setting

Select **Dynamic Time** to set the system to wake on the current time + increase minute (s).

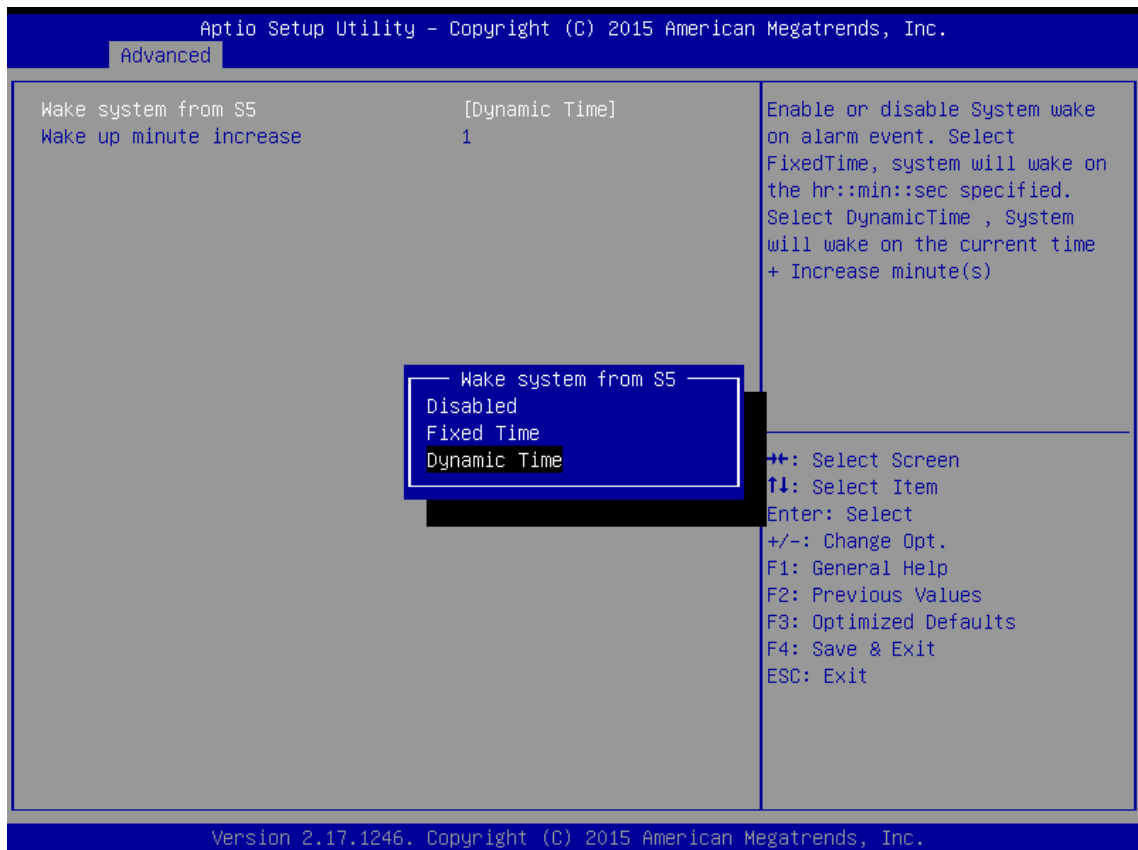

4.2.2.5 CPU Configuration

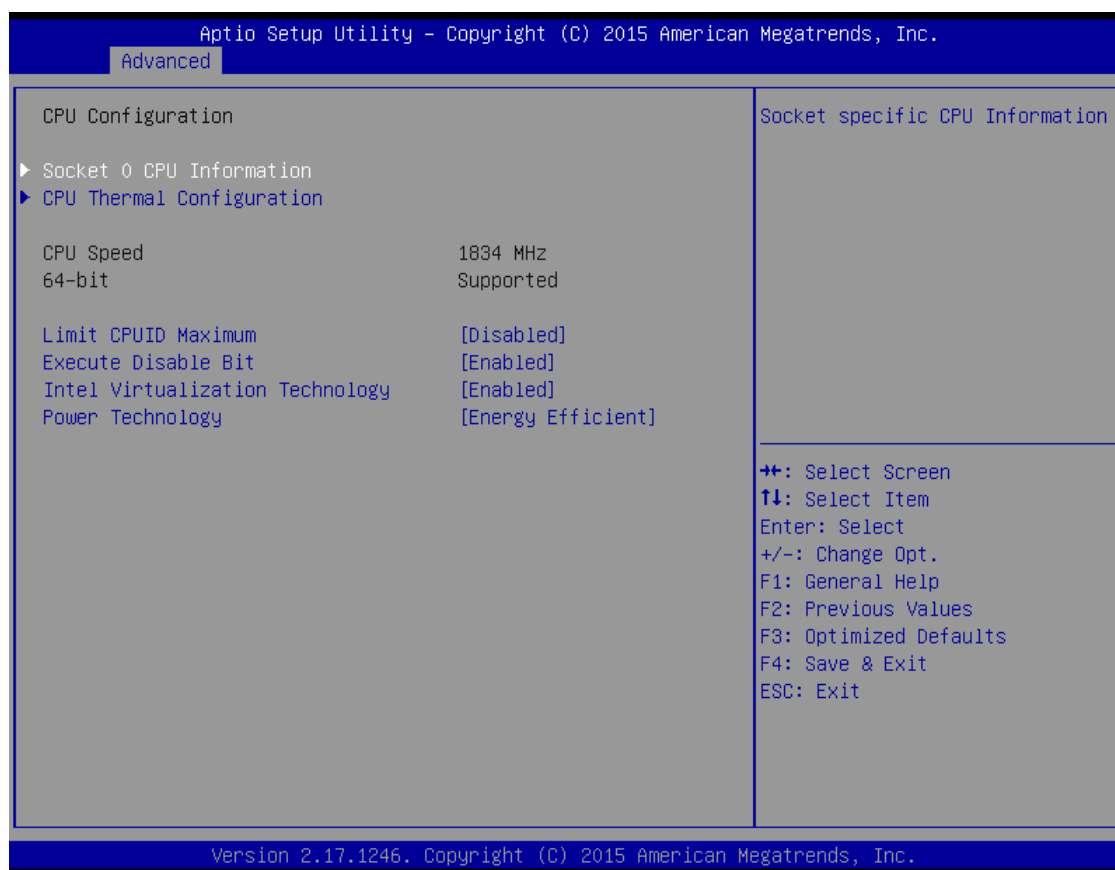

BIOS Setting	Description	Setting Option	Effect
Socket CPU Information	This item contains socket specific CPU information.	Enter	Open sub-menu
CPU Thermal Configuration	Thermal control	Enter	Open sub-menu
Limit CPUID Maximum	Limits CPIID Maximum	Disabled/Enabled	Enable/Disable this function
Execute Disable Bit	Execute Disable Bit	Disabled/Enabled	Enable/Disable this function
Intel Virtualization Technology	Allows to run recent OS and applications	Enabled/Disabled	Enable/Disable this function
Power Technology	Control the performance and power management functions of the processors	Disabled	Disable this function
		Energy Efficient	Enable energy efficient mode

4.2.2.6 PPM Configuration



BIOS Setting	Description	Setting Option	Effect
CPU C State Report	Shows CPU C State Report	Enabled/ Disabled	Enable or Disable CPU C state report to OS
Max CPU C-State	Allows to enter power-saving mode in order to save energy	C1, C3, C6, C7, Auto	Enable or Disable CPU C Max CPU S-Sate

4.2.2.7 Thermal Configuration

This menu allows controlling thermal settings of the computer. Refer to the descriptions on the top right side of the screen for detailed information about each setting.



BIOS Setting	Description	Setting Option	Effect
Critical Trip Point	Specifies the temperature at which the OS will shut down the system	90C, 87C, 85C, 79C, 71C, 63C,55C,47C, 39C, 31C, 23C, 15C	Select the disable temperature for the system to shut down
Passive Trip Point	Specifies the temperature at which the OS will begin adjusting the processor	90C, 87C, 85C, 79C, 71C, 63C,55C,47C, 39C, 31C, 23C, 15C	Select the disable temperature for the system to start adjusting the processor

4.2.2.8 IDE Configuration

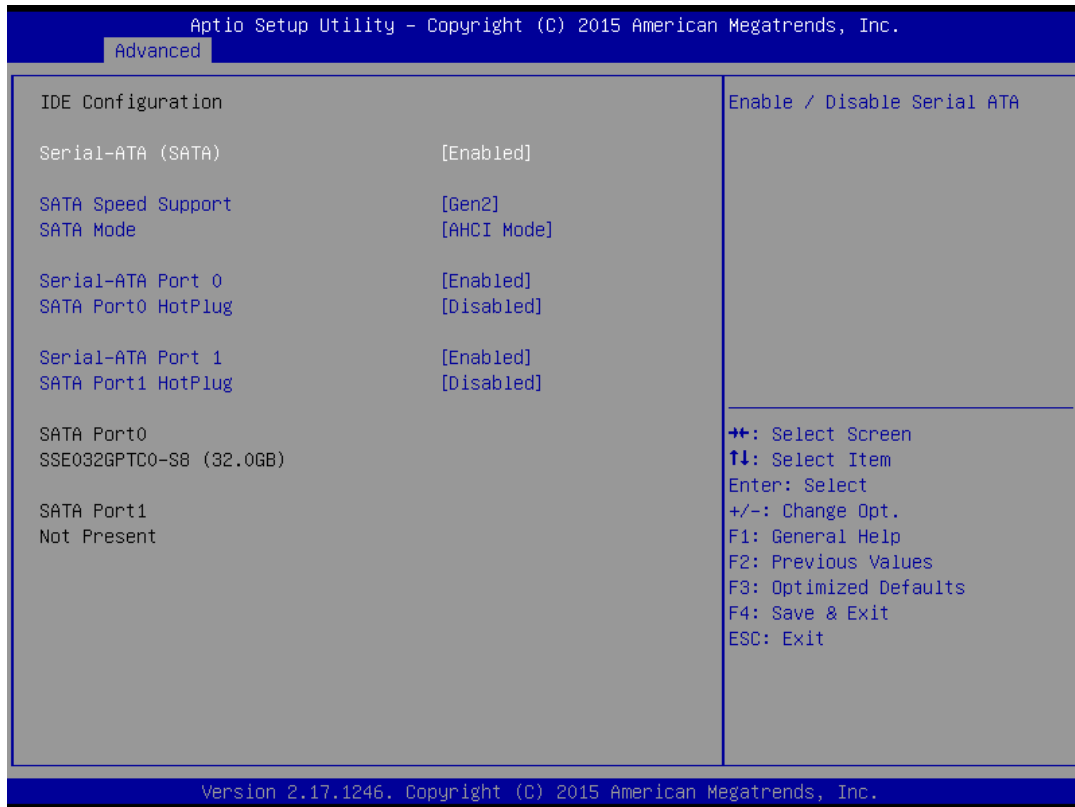

BIOS Setting	Description	Setting Option	Effect
Serial- ATA (SATA)	Responsible for supporting chipset drives with SATA interface.	Enabled/ Disabled	Enable or disable this function
SATA Speed Support	Allows forcing the speed limit SATA II ports standard IDE / SATA-controller chipset.	Gen1	The maximum speed will be limited to 150 MB/s
		Gen2	The maximum speed will be limited to 300 MB/s
		Disabled	Disables manual configuration of SATA II ports (mode will be selected based on the specifications of connected drives)
SATA Mode	This option specifies the operation mode of modern IDE / SATA-controller chipset	[AHCI]	Selecting this option allows you to take full advantage of the extended host controller SATA II
		[IDE]	SATA controller will operate in a mechanism similar to a conventional IDE-controller
		[RAID]	Allows combining hard drives in RAID-arrays in order to improve the reliability of data storage, or to increase the speed.
Serial- ATA Port 0	The option turns on or off Port 0 of SATA channels of standard IDE / SATA-controller chipset.	Enabled/ Disabled	Turn on (Enabled) or turn off (Disabled) Port 0

BIOS Setting	Description	Setting Option	Effect
SATA Port0 HotPlug	This feature that allows you to attach and remove a SATA Port0	Enabled/ Disabled	Enable or disable this function
Serial- ATA Port 1	The option turns on or off Port 1 of SATA channels of standard IDE / SATA-controller chipset.	Enabled/ Disabled	Turn on (Enabled) or turn off (Disabled) Port 1
SATA Port1 HotPlug	This feature that allows you to attach and remove a SATA Port1	Enabled/ Disabled	Enable or disable this function

4.2.2.9 Miscellaneous Configuration

OS Selection

This item allows users to select the proper Operating System.

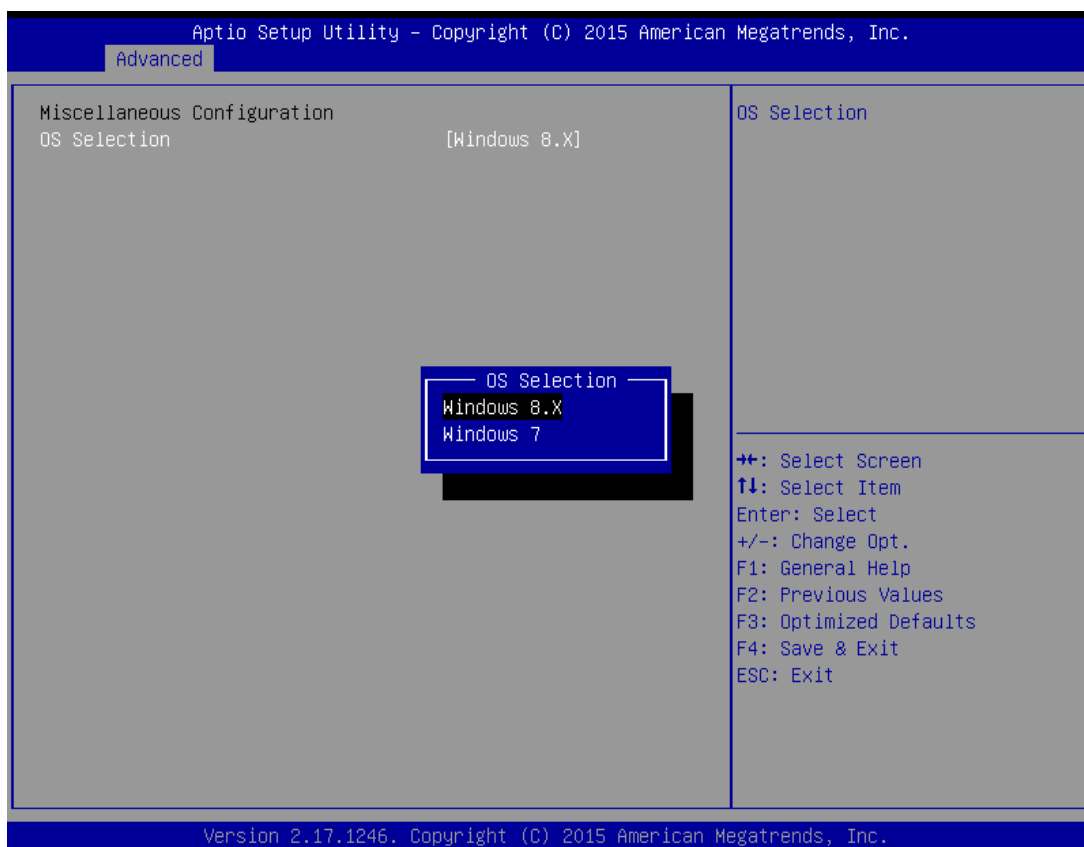

BIOS Setting	Description	Setting Option	Effect
Windows 8.X	Allows user to choose the proper OS.	Enter	Use Windows 8.X
Windows 7	Allows user to choose the proper OS.	Enter	Use Windows 7



Important: The device will be shipped with OS according to your order. BIOS OS Selection menu varies accordingly.

4.2.2.10 CSM Configuration

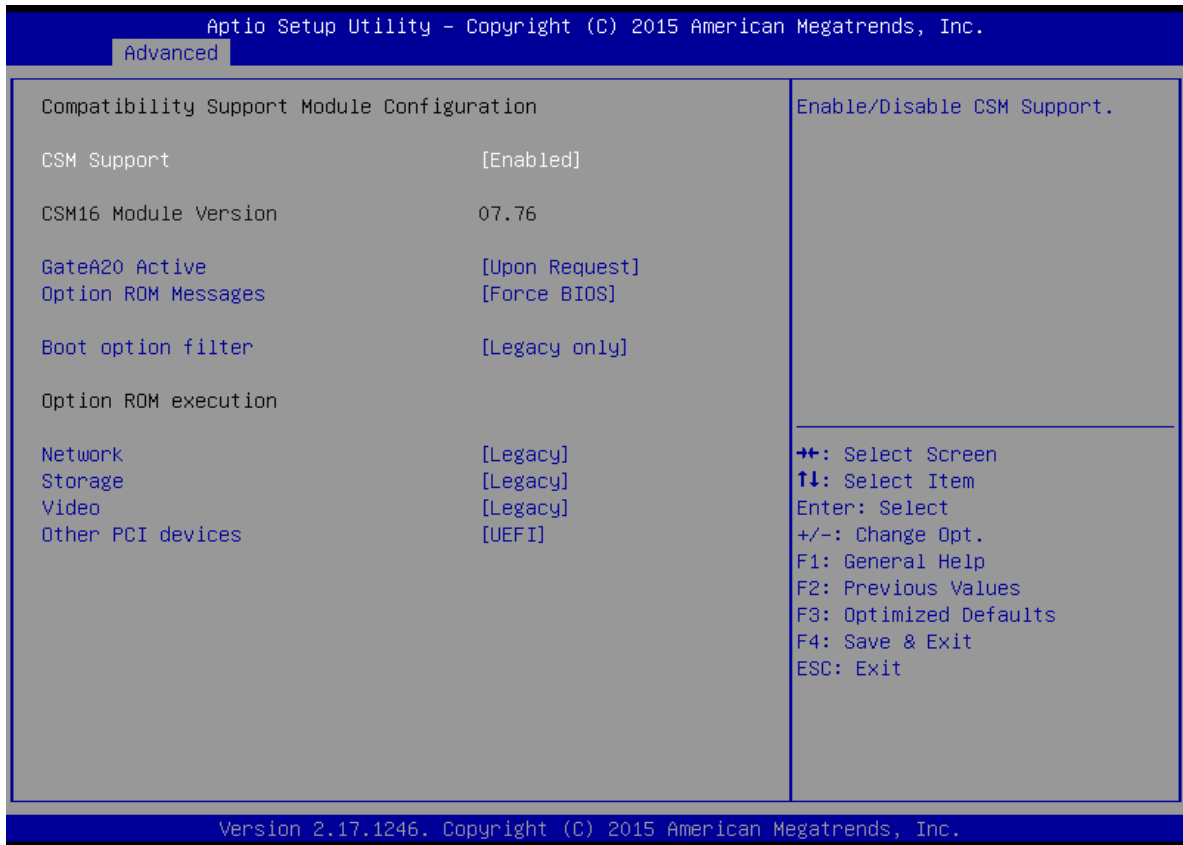

BIOS Setting	Description	Setting Option	Effect
CSM Support	The Compatibility Support Module (CSM) is a component of the UEFI firmware that provides legacy BIOS compatibility by emulating a BIOS environment, allowing legacy operating systems and some option ROMs that do not support UEFI to still be used.	Enabled/ Disabled	Enable or disable the Compatibility Support Module
GetaA20 Active	Activate GetaA20	Upon Request	Enable or disable this function
Option ROM Messages	Receiving ROM Messages Settings	Force BIOS	Set ROM messages parameters
Network	Specifies which Network option ROM is booted	UEFI	Only UEFI option ROMs are booted
		Legacy	
Storage	Specifies which Storage option ROM is booted	UEFI	Only UEFI option ROMs are booted
		Legacy	Only Legacy option ROMs are booted
Video	Specifies which Video option ROM is booted	UEFI	Only UEFI option ROMs are booted
		Legacy	Only Legacy option ROMs are booted
Other PCI Devices	Specifies which option ROM is booted for devices other than the network, storage or video	UEFI	Only UEFI option ROMs are booted
		Legacy	Only Legacy option ROMs are booted

4.2.2.11 USB Configuration

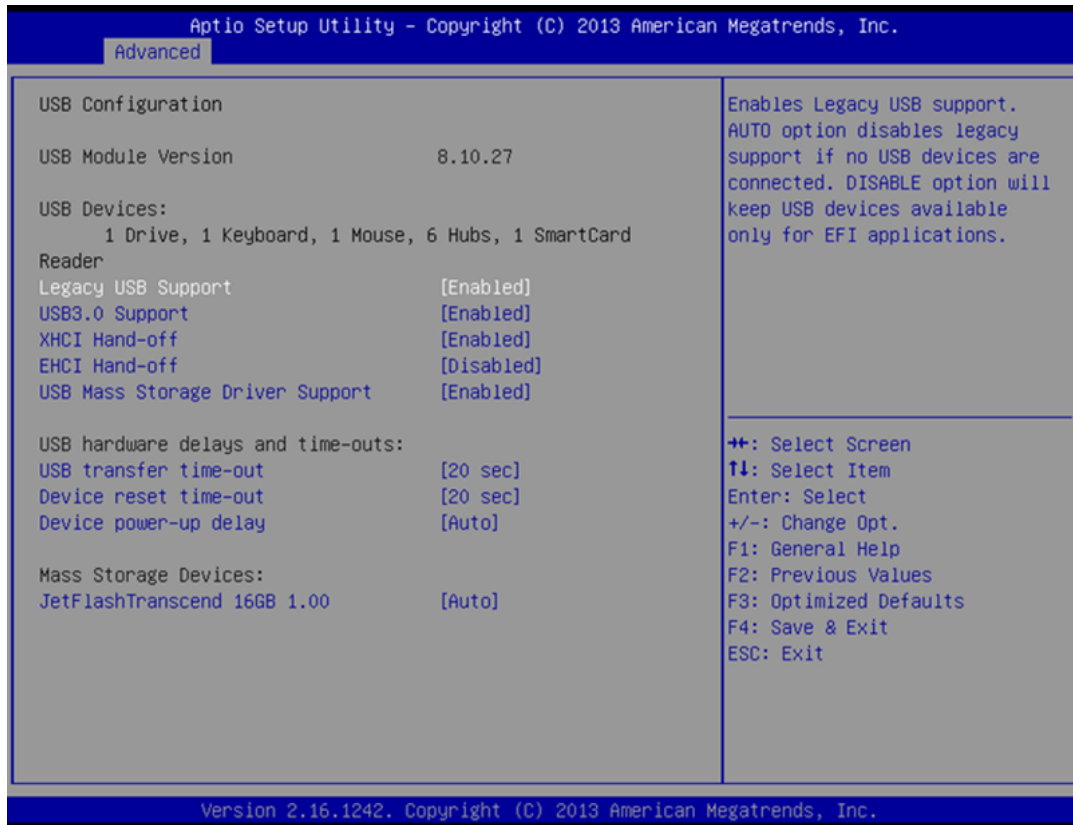

BIOS Setting	Description	Setting Option	Effect
Legacy USB Support	User can enable or disable USB port.	Disable	Keep USB devices available only for EFI applications.
		Enable	Enable all the USB devices
USB 3.0 Support	User can enable or disable USB 3.0 (XHCI) controller support.	Enable	Enable USB 3.0 is enabled
		Disable	USB 3.0 is disable
XHCI Hand-off	This is a workaround for OSs without XHCI hand- off support.	Disable	Disables this function
		Enable	Enables this function
EHCI Hand-off	This is a workaround for OSs without ECHI hand- off support.	Disable	Disables this function
		Enable	Enables this function
USB mass storage driver support	User can Enable or disable USB mass storage driver support.	Disable	Disables this function
		Enable	Enables this function
USB Transfer time- out	The time-out value for control, bulk, and interrupt transfers.	1 Sec 5 Sec 10 Sec 20 Sec	Depends on the time-out value
Device Reset time- out	USB mass storage device start unit command time-out.	10 Sec 20 Sec 30 Sec 40 Sec	Depends on the time-out value
Device power-up delay	Maximum time the device will take before it properly reports itself to the host controller.	Auto	Uses default value: for a root port it is 100 ms, for a Hub port the delay is taken from Hub descriptor

4.2.2.12 Security Configuration

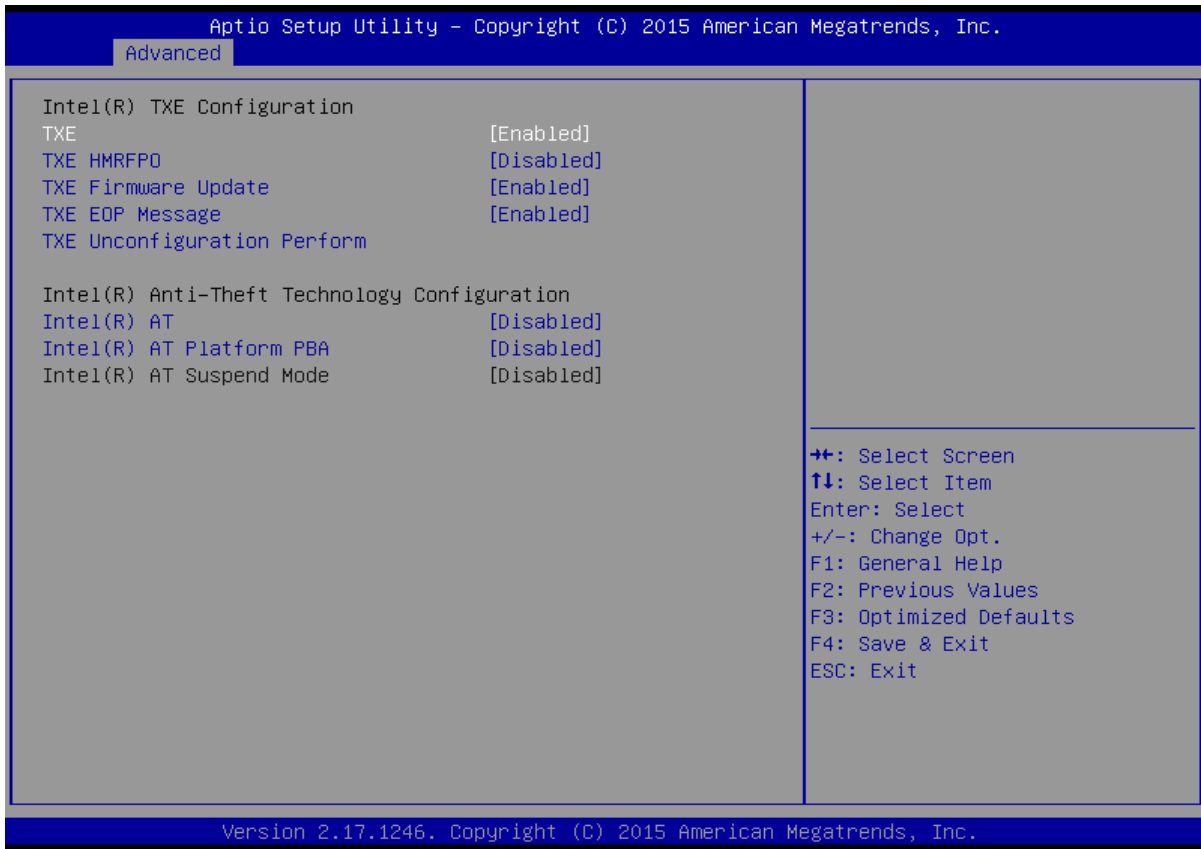

BIOS Setting	Description	Setting Option	Effect
TXE	Trusted Execution Technology parameters	Enabled/Disabled	Enables or disables this function
TXE HMRFPO	TXE HMRFPO parameters	Enabled/Disabled	Enables or disables this function
TXE Firmware Update	TXE Firmware Update parameters	Enabled/Disabled	Enables or disables this function
TXE EOP Message	TXE EOP Message parameters	Enabled/Disabled	Enables or disables this function
Intel® AT	Intel® AT parameters	Enabled/Disabled	Enables or disables this function
Intel® AT Platform PBA	Intel® AT Platform PBA parameters	Enabled/Disabled	Enables or disables this function

4.3 Chipset Menu

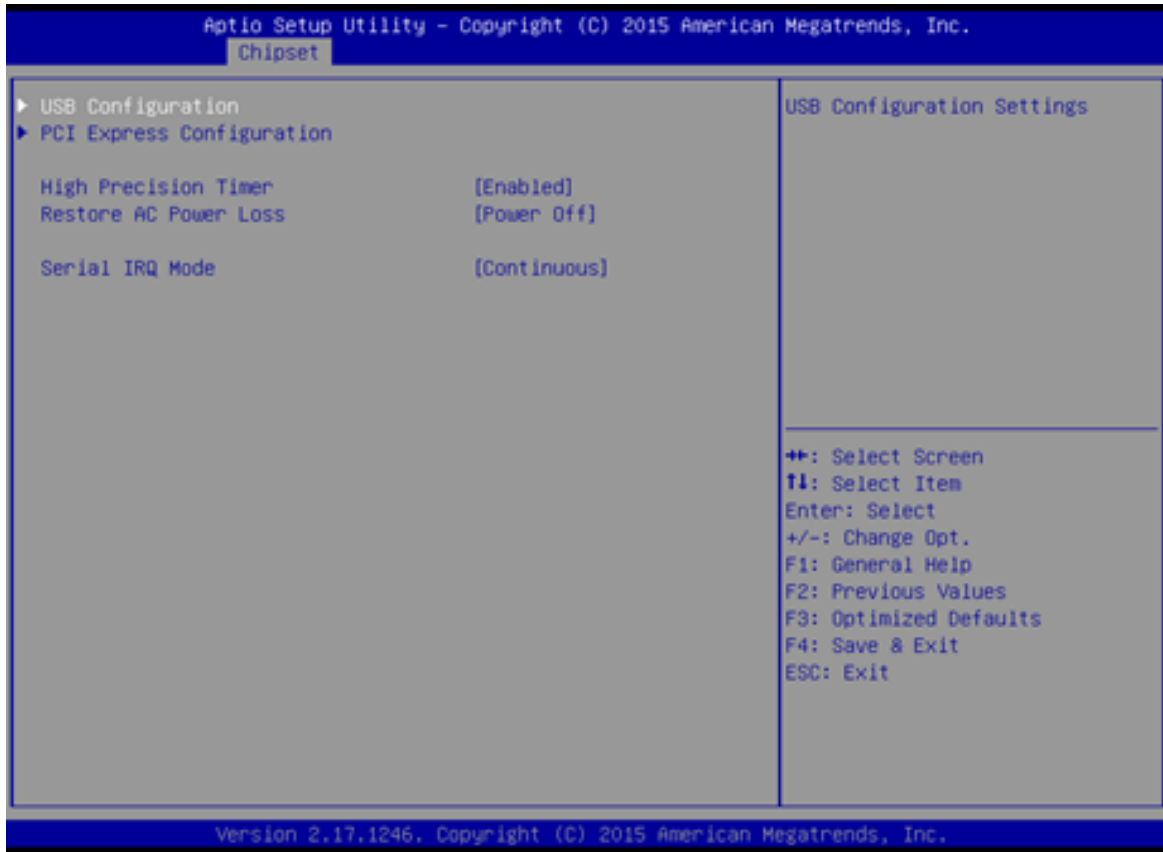

BIOS Setting	Description	Setting Option	Effect
High Precious Timer	Allow to set up High Precious Timer settings	Enabled/ Disabled	Enables/Disables this function
Restore AC Power Loss	This function allows to set up booting options after a power failure	Power on/ Power off	Boot automatically after a power failure
Serial IRQ Mode	When working with personal computer hardware, installing and removing devices, the system relies on interrupt requests. Interrupt request	Continuous	Allow user to set up desired IRQ Mode

4.4 Security Menu

In the Security menu, users can set administrator password, user password, and HDD security configuration.



BIOS Setting	Description	Setting Option	Effect
Administrator Password	Displays whether or not an administrator password has been set.	Enter	Enter password
User Password	Display whether or not a user Password has been set.	Enter	Enter password

4.5 Boot Configuration

The Boot menu sets the sequence of the devices to be searched for the operating system. The bootable devices will be automatically detected during POST and shown here, allowing you to set the sequence that the BIOS uses to look for a boot device from which to load the operating system.

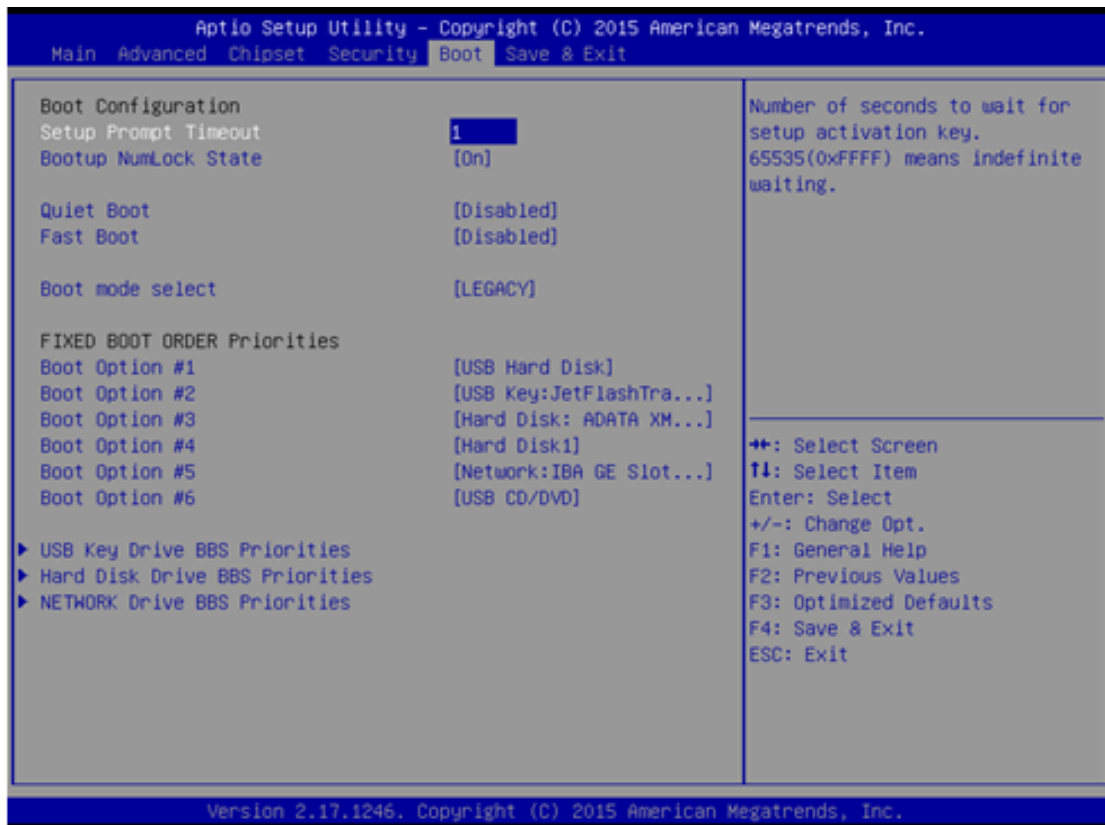

BIOS Setting	Description	Setting Option	Effect
Setup Prompt Timeout	Allows user to configure the number of seconds to stay in BIOS setup prompt screen.	Enter	Set the prompt timeout
Boot NumLock State	Enables or disables NumLock feature on the numeric keypad of the keyboard after the POST (Default: On).	On	Remains On
		Off	Remains OFF
Quiet Boot	Determines if POST message or OEM logo (default = Black background) is displayed.	Disabled	Disables this function
		Enabled	Enables this function
Fast Boot	Enables or disables Fast Boot to shorten the OS boot process. (Default: Disabled).	Disabled	Disables this function
		Enabled	Enables this function
Boot Mode Select	Specifies which mode will be used for booting	Legacy	Only Legacy option is booted
		UEFI	Only UEFI option is booted
Boot Option #1~#6	Specifies the overall boot order from the available devices	Ex: Boot Option#1 (hard drive)	Hard drive as the first priority

BIOS Setting	Description	Setting Option	Effect
USB Key Drive BBS Priorities	USB Key Drive BBS Priorities	Enter	Open sub-menu
Hard Disk Drive BBS Priorities	Hard Disk Drive BBS Priorities	Enter	Open sub-menu
Network Drive BBS Priorities	Network Drive BBS Priorities	Enter	Open sub-menu

4.6 Save & Exit

The Exit menu displays a way how to exit BIOS Setup utility. After finishing your settings, you must save and exit for changes to be applied.

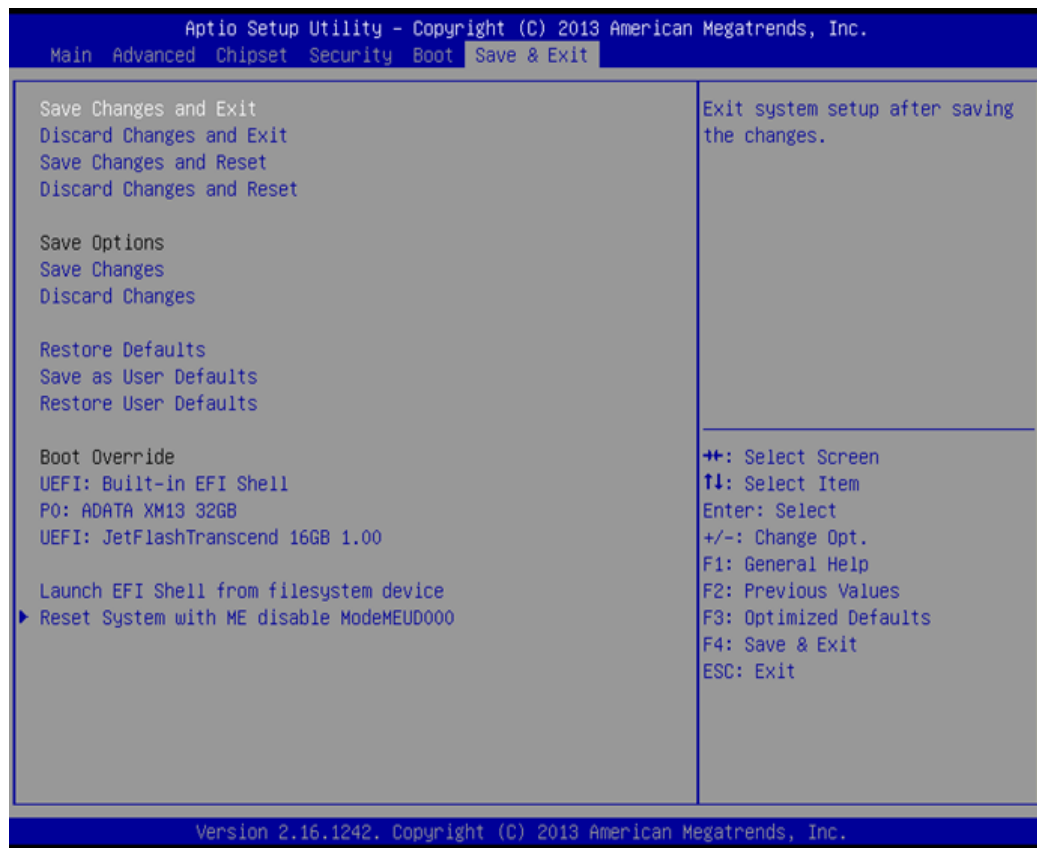

BIOS Setting	Description	Setting Option	Effect
Save Changes and Exit	This saves the changes to the CMOS and exits the BIOS Setup program.	Enter <YES>	Save changes
Discard Changes and Exit	This exits the BIOS Setup without saving the changes made in BIOS Setup to the CMOS.	Enter <YES>	Saves the changes
		Enter <NO>	Return to the BIOS Setup Main Menu
Save Changes and Reset	Reset the system after saving the changes.	Enter <YES>	Saves the changes
		Enter <NO>	Return to the BIOS Setup Main Menu
Discard Changes	Reset system setup	Enter <YES>	Saves the changes

BIOS Setting	Description	Setting Option	Effect
and Reset	without saving any changes	Enter <NO>	Return to the BIOS Setup Main Menu
Save Changes	Save changes done so far to any of the setup options.	Enter <YES>	Saves the changes
		Enter <NO>	Return to the BIOS Setup Main Menu
Discard Changes	Discard changes done so far to any of the setup options.	Enter <YES>	Saves the changes
		Enter <NO>	Return to the BIOS Setup Main Menu
Restore Default	Restore/load default values for all the setup options.	Enter <YES>	Saves the changes
		Enter <NO>	Return to the BIOS Setup Main Menu
Save as User Defaults	Save the changes done so far as User defaults.	Enter <YES>	Saves the changes
		Enter <NO>	Return to the BIOS Setup Main Menu
Restore User Defaults	Restore the User Defaults to all the setup options.	Enter <YES>	Saves the changes
		Enter <NO>	Return to the BIOS Setup Main Menu

4.7 Using Recovery Wizard to Restore Computer

The Panel PC has a dedicated recovery partition stored on the hard drive of the PC to enable quick one-key recovery process. This partition occupies about 11GB of the storage space, and comes built-in to the PC.



Note: Before starting the recovery process, make sure to backup all user data. The data will be lost after the recovery process.

To enable quick one-key recovery procedure:

- Plug-in the AC adapter to Bay Trail series computer. Make sure the computer stays plugged in to power source during the recovery process.
- Turn on the computer, and when the boot screen shows up, press the **F6** to initiate the Recovery Wizard.
- The following screen shows the Recovery Wizard. Click **Recovery** button to continue.



A warning message about data loss will show up. Make sure the data is backed up before recovery, and click **Yes** to continue.



Wait the recovery process to complete. During the recovery process, a command prompt will show up to indicate the percent of recovery process complete. The system will restart automatically after recovery completed.

Chapter 5: Driver Installation

This chapter provides guideline to driver installations.

5.1 Installing Chipset Driver

Step 1 Insert the CD that comes with the motherboard. Open the file document “**Chipset Driver**” and click “**infinst_auto.exe**” to install driver.

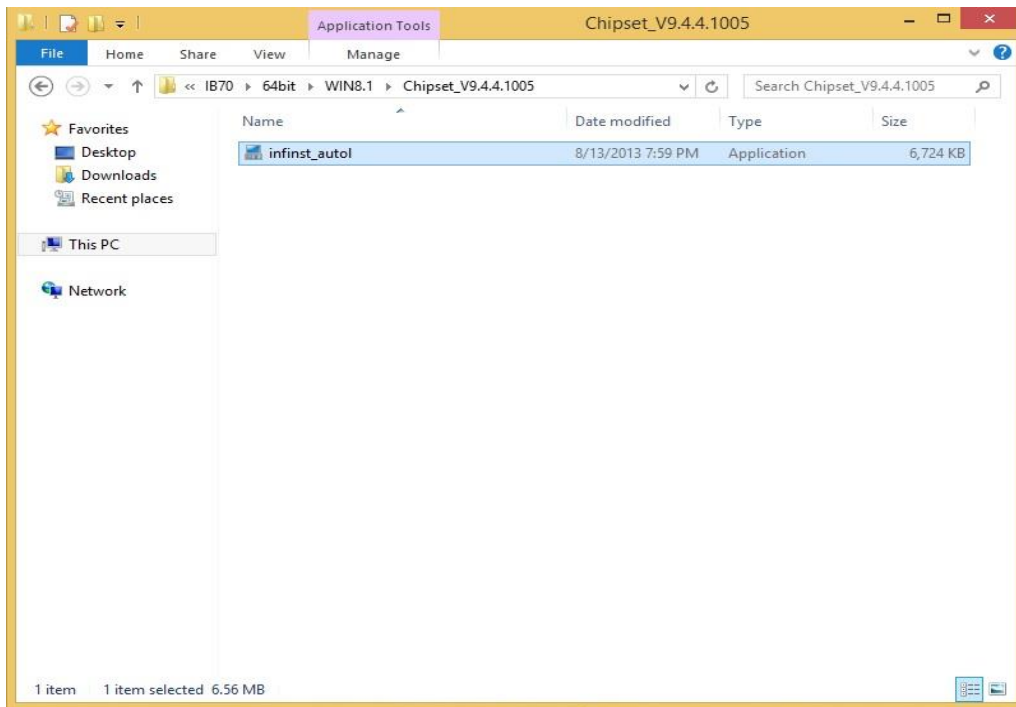

Step 2 Click **Next** to continue.



Step 3 Click **Yes** to agree the license terms.



Step 4 Click **Next** to install the driver.

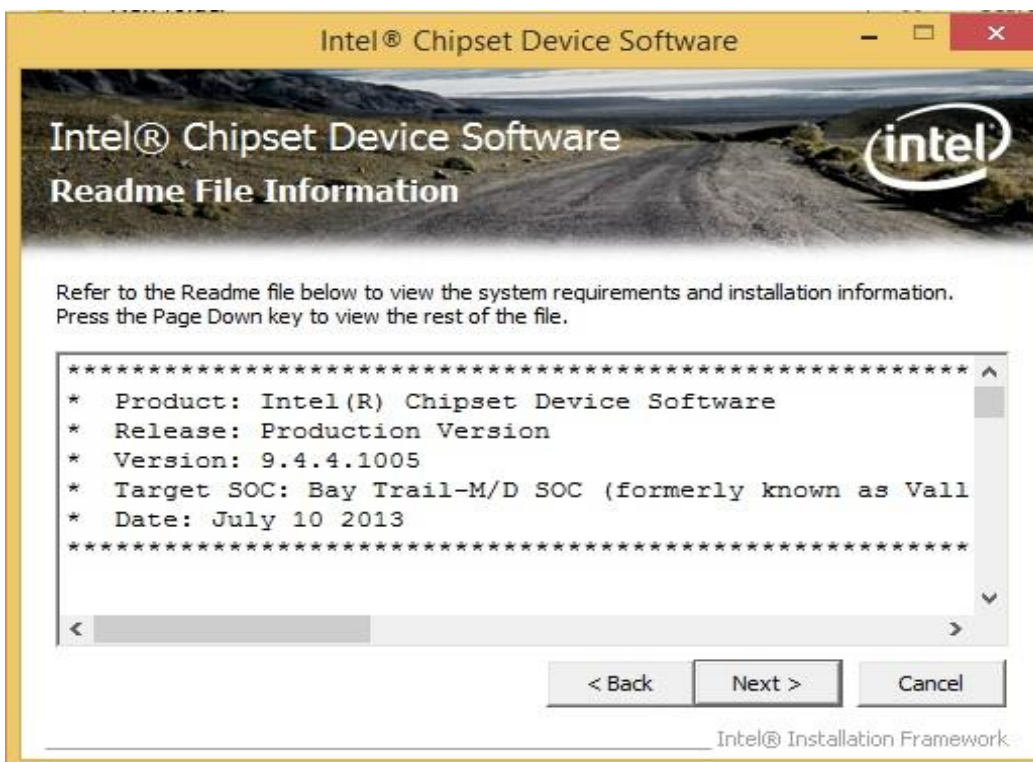

Step 5 Software setup progress window will appear, click **Next** to continue.

Step 6 Click "Yes, I want to restart this computer now" to finish the installation.

5.2 Installing Graphics Driver

Step 1 Insert the CD that comes with the motherboard. Open the file document “**Graphics Driver**” and click **Setup** to execute the setup.

Step 2 Setup Welcome Window will appear, click **Next** to continue the process.

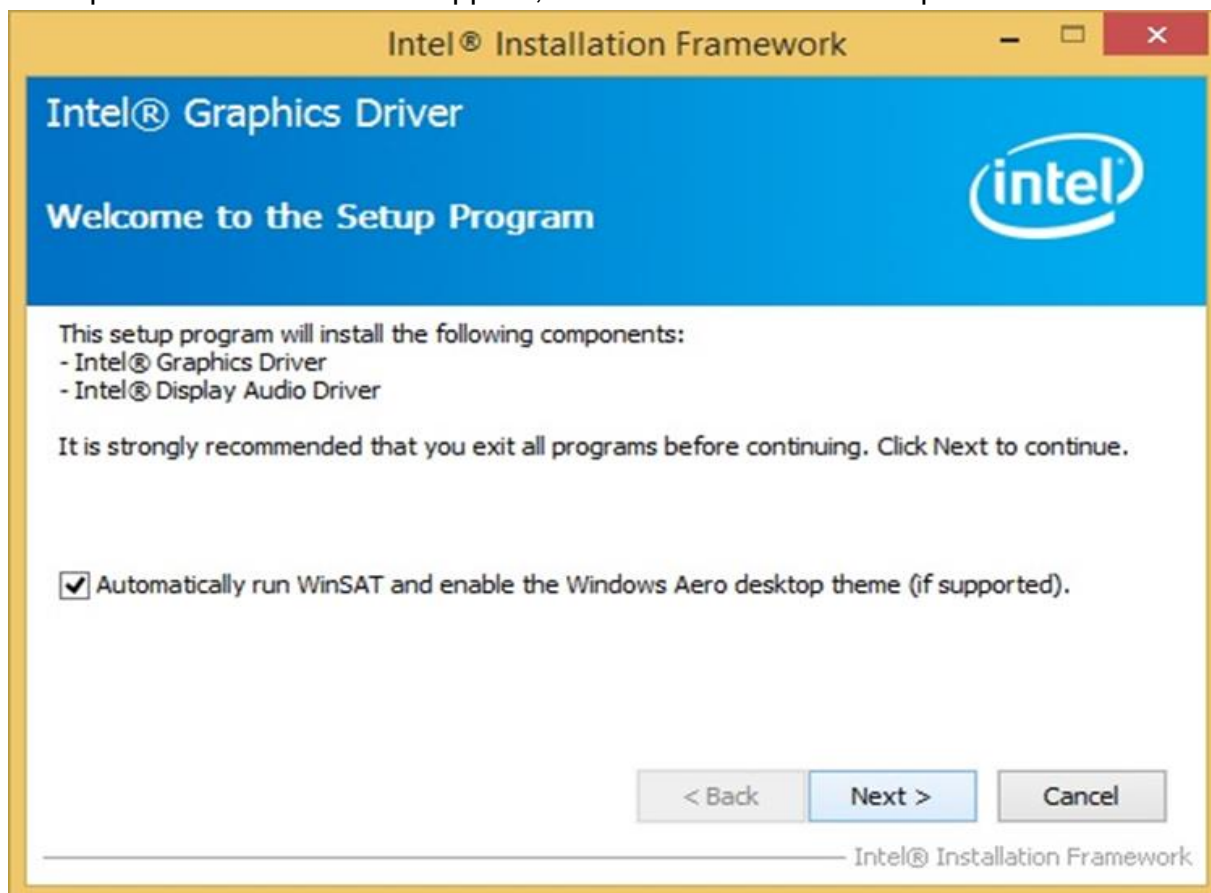

Step 3 Carefully read the license terms and click **Yes** to agree.

Step 4 Check Readme file information, and click **Next** to install driver.

Step 5 Click **Next** to continue.

Step 6 Windows Security window will appear, click “**Install this driver software anyway**” to continue.

Step 7 Setup Progress window will appear, click **Next** to continue the installation.

Step 8 Setup is complete, click “**Yes, I want to restart this computer now**” to finish the installation and restart the computer.

5.3 Installing Intel Sideband Fabric Device Driver

Only for Windows 8

Step 1 Insert the CD that comes with the motherboard. Open the file document “**MBI**” and click “**Setup.exe**” to install the driver.

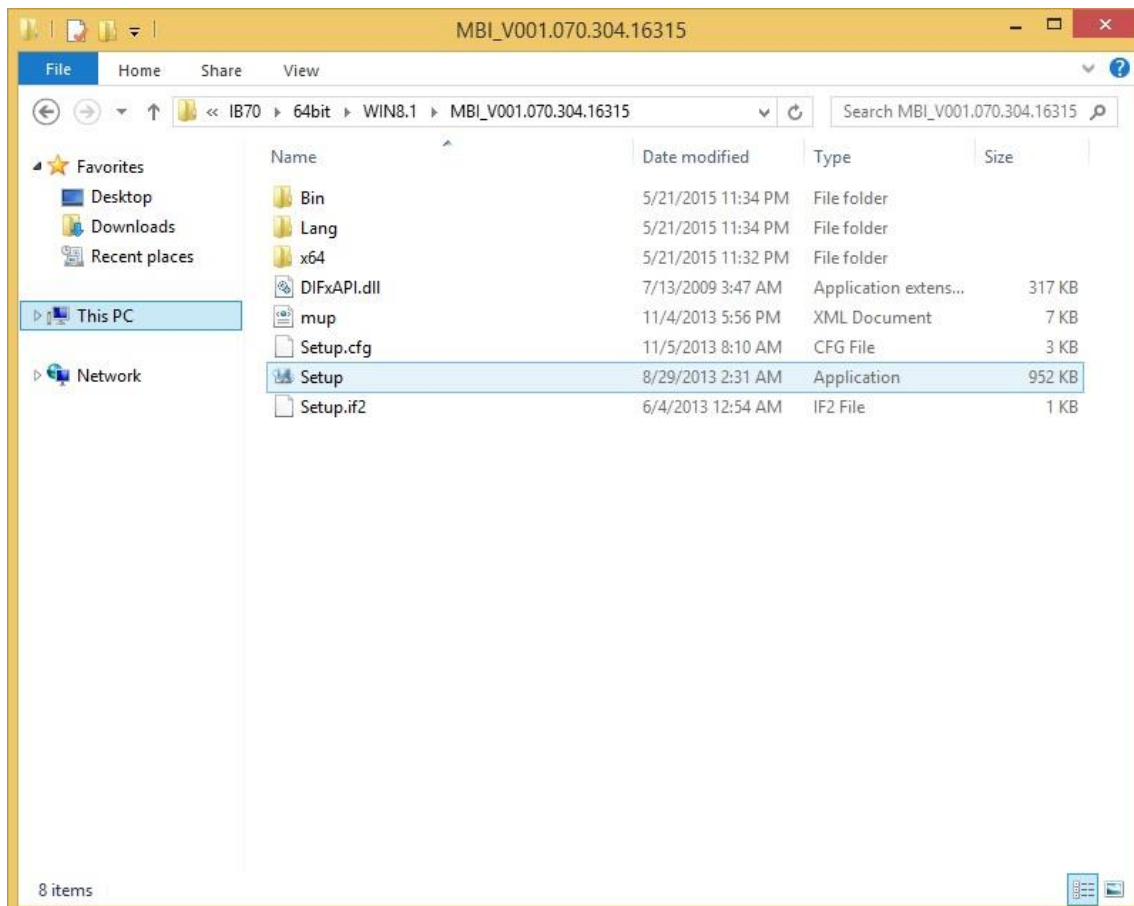

Step 2 Welcome to the setup program window will appear, click **Next** to start the installation.

Step 3 Carefully read the License Agreement terms and click **Yes** to agree.

Step 4 Setup progress will appear, please wait for the operations to be performed, then click **Next** to continue.

Step 5 The installation is complete, click “**Yes, I want to restart this computer now**” to finish and restart the computer.

5.4 Installing Intel Trusted Engine Interface Driver

Step 1 Insert the CD that comes with the motherboard. Open the file document “TXE” and click “Setup TXE.exe” to install the driver.

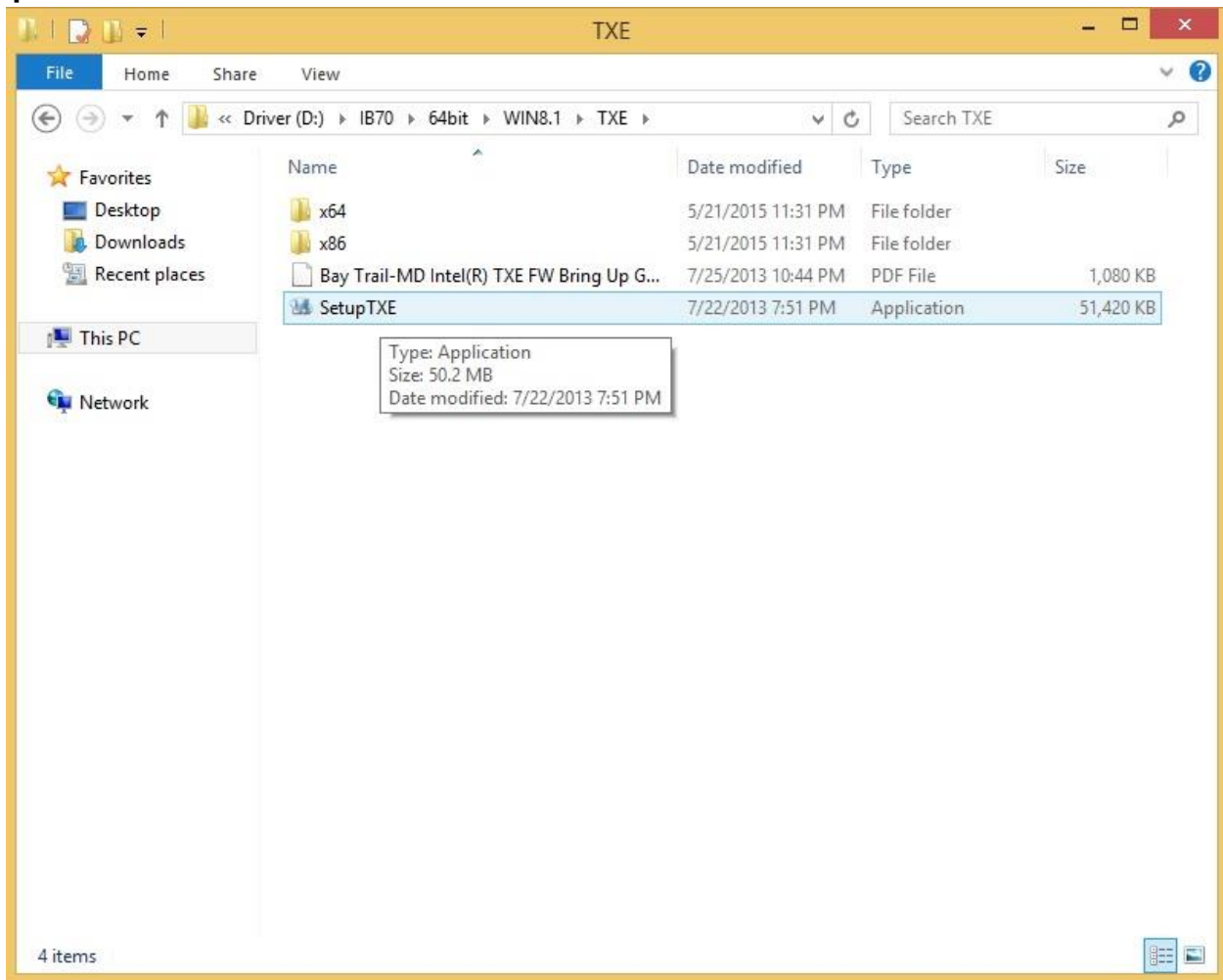

Step 2 Welcome to the setup program window will appear, click **Next** to start the installation.

Step 3 Carefully read the license terms and click **Yes** to agree.

Step 4 Confirmation window will appear, click **Next** to continue the driver installation.

Step 5 Please wait while the product is being installed.

Step 6 The installation is complete, click **Finish** to complete the installation and restart the computer.

5.5 Installing Intel Network Connections

User must confirm the type of operating system is being used before installing Intel Network Connections. Follow the steps below to complete the installation.

Step 1 Click “PROWin64.exe”

Step 2 Click **Yes** to start the installation.

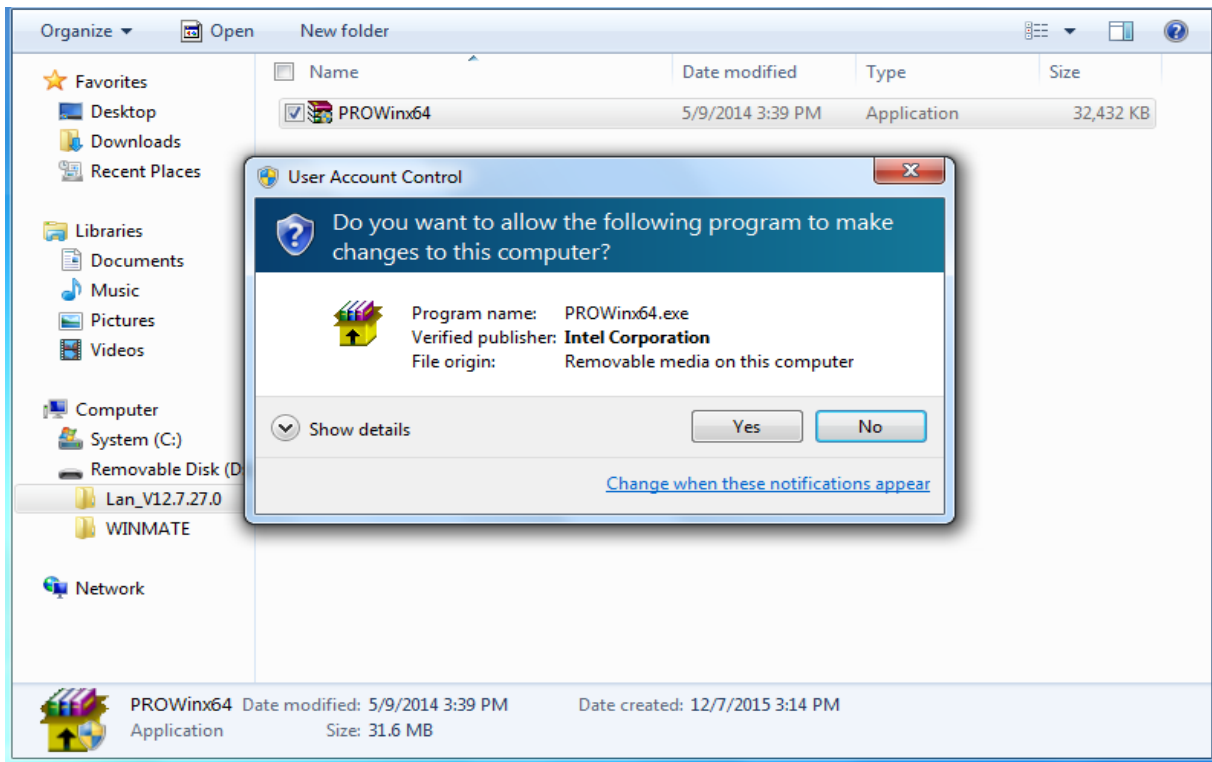

Step 3 Welcome window will appear, click **Next** to install the driver.

Step 4 In the program maintenance window you will see two options available. “Remove” is to remove Intel Networks Connections from your computer, and “Modify” is to make any changes. Choose **Modify** to continue.

Step 5 In the **Setup Options** window choose “Intel® PRO Set for Windows® Device Manger”, “Intel ® Network Connections SNMP Agent” and “Advanced Network Services”.

Step 6 The wizard is ready to begin installation, click **Install** to continue.

Step 7 Install wizard completed, click **Finish** to complete the installation.

5.6 Installing Audio Driver

The ALC886 series are high-performance 7.1+2 channel high definition audio codecs that provide ten DAC channels for simultaneous support of 7.1 sound playback, plus 2 channels of independent stereo sound output (multiple streaming) through the front panel stereo outputs. The series integrates two stereo ADCs that can support a stereo microphone, and feature Acoustic Echo Cancellation (AEC), Beam Forming (BF), and Noise Suppression (NS) technology.

Step 1 Insert the CD that comes with the motherboard. Open the file document “Audio Driver” and click “Setup.exe” to install the driver.

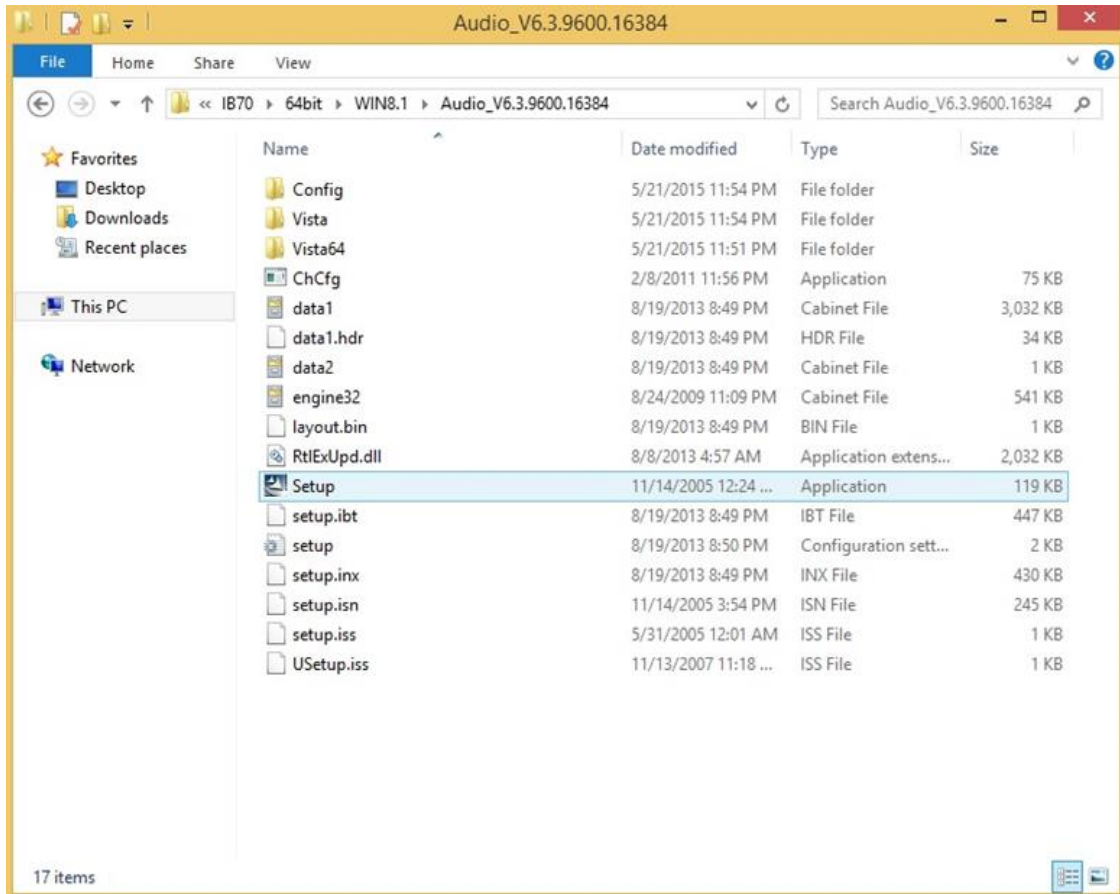

Step 2 Please wait while the InstalShield Wizard prepares the setup.

Step 3 Welcome window will appear, click **Next** to install the driver.

Step 4 It might take some time to configure new software installation. Please wait.

Step 5 Windows security will appear, click **Install** to install the audio driver.

Step 6 The installation is complete, select “**Yes, I want to restart my computer now**”, and click **Finish** to complete the installation.

Chapter 6: Maintenance and Troubleshooting

6.1 Cleaning the Monitor



Note: The IP65 Stainless Panel PC withstands regular frequent cleaning and disinfection.

Before cleaning:

- Make sure the device is turned off.
- Disconnect the power cable from any AC outlet.

When cleaning:

- Use water up to 80°C to clean the housing.
- Wipe the screen with a clean, soft, lint-free cloth. This removes dust and other particles.
- The display area is highly prone to scratching. Do not use ketene type material (ex. Acetone), Ethyl alcohol, toluene, ethyl acid or Methyl chloride to clear the panel. It may permanently damage the panel and void the warranty.
- If it is still not clean enough, apply a small amount of non-ammonia, non-alcohol based glass cleaner onto a clean, soft, lint-free cloth, and wipe the screen.
- Do not use oil directly on the display screen. If droplets are allowed to drop on the screen, permanent staining or discoloration may occur.

6.2 Basic Troubleshooting

Problem	Solution
There is a black dot or dead pixel dot on the screen	A missing pixel does not constitute an out of spec. defective product
Cannot turn power on	Turn off the power supply, and check that the AC cord or DC cord are securely inserted. After checking, turn on the power supply again.
There are spots on the screen	There may be electrical distortion from vehicles, trains, high voltage lines or fluorescent lamps.
Bad color	Color density or tint control may not be adjusted properly (Check the adjusted value of image.)
Image appears and disappears	Input may not be connected properly.
When changing the screen size, the top and bottom part of the screen does not show images	When using a video software program (such as a cinema size program) with a screen wider than one in the 16:9 mode, blank areas separate from the images are formed at the top and bottom of the screen.
Image contour flickers	Due to the characteristics of the display control, contour of animated parts of images may seem to flicker, but that is not a breakdown.

Appendix

Appendix A: Hardware Specifications

	Model Name			
	W10IB3S-SPH2-B	R15IB3S-SPC3-B	R19IB3S-SPM1-B	W22IB3S-SPA3-B
Display				
Size	10.1"	15"	19"	21.5"
Resolution	1024 x 600	1024 x 768	1280 x 1024	1920 x 1080
Brightness	800:1	2000:1	1000:1	3000:1
Contrast Ratio	450 nits	300 nits	250 nits	250 nits
Viewing Angle	75,80,80,80	88,88,88,88	85,85,80,80	89,89,89,89
Touch	Projected capacitive multitouch screen	Projected capacitive multitouch screen	Projected capacitive multitouch screen	Projected capacitive multitouch screen
System Specifications				
CPU	Intel® Celeron® N2930 (2M Cache, up to 2.16 GHz)	Intel® Celeron® N2930 (2M Cache, up to 2.16 GHz)	Intel® Celeron® N2930 (2M Cache, up to 2.16 GHz)	Intel® Celeron® N2930 (2M Cache, up to 2.16 GHz)
System Chipset	Intel® SoC integrated	Intel® SoC integrated	Intel® SoC integrated	Intel® SoC integrated
System Memory	1 x SODIMM, Max 8GB DDR3 1600 MHz, default 4GB	1 x SODIMM, Max 8GB DDR3 1600 MHz, default 4GB	1 x SODIMM, Max 8GB DDR3 1600 MHz, default 4GB	1 x SODIMM, Max 8GB DDR3 1600 MHz, default 4GB
Storage	Default 1 x mSATA SSD 64GB	Default 1 x mSATA SSD 64GB	Default 1 x mSATA SSD 64GB	Default 1 x mSATA SSD 64GB
BIOS	AMI BIOS	AMI BIOS	AMI BIOS	AMI BIOS
Audio Codec	Realtek HD codec	Realtek HD codec	Realtek HD codec	Realtek HD codec
Expansion	1 x mPCIe slot (for half size Wi-Fi module)	1 x mPCIe slot (for half size Wi-Fi module)	1 x mPCIe slot (for half size Wi-Fi module)	1 x mPCIe slot (for half size Wi-Fi module)
Network	Intel® Ethernet Controller I210-AT	Intel® Ethernet Controller I210-AT	Intel® Ethernet Controller I210-AT	Intel® Ethernet Controller I210-AT
Operating System	Windows 10 IoT Enterprise (Optional)	Windows 10 IoT Enterprise (Optional)	Windows 10 IoT Enterprise (Optional)	Windows 10 IoT Enterprise (Optional)
Interface				
Ethernet LAN	1 x M12 waterproof connector for 1 x USB2.0 & GigaLAN	1 x waterproof Giga LAN RJ45 connector	1 x waterproof Giga LAN RJ45 connector	1 x waterproof Giga LAN RJ45 connector
COM	1 x M12 waterproof connector for RS-232	1 x M12 waterproof connector for RS-232	1 x M12 waterproof connector for RS-232	1 x M12 waterproof connector for RS-232
USB	1 x M12 waterproof connector for 1 x USB2.0 & GigaLAN	1 x M12 waterproof connector for 2 x USB2.0, 1 x Front waterproof connector for USB2.0 type-A	1 x M12 waterproof connector for 2 x USB2.0, 1 x Front waterproof connector for USB2.0 type-A	1 x M12 waterproof connector for 2 x USB2.0, 1 x Front waterproof connector for USB2.0 type-A
Power Input	1 x M12 waterproof connector for 12V DC	1 x M12 waterproof connector for 12V DC	1 x M12 waterproof connector for 12V DC	1 x M12 waterproof connector for 12V DC
Expansion Port	CN1 and CN2 for front button control	CN1 and CN2 for front button control	CN1 and CN2 for front button control	CN1 and CN2 for front button control
Keyboard and Input				
Physical Buttons	Rear side:	Rear side:	Rear side:	Rear side:

	Model Name			
	W10IB3S-SPH2-B	R15IB3S-SPC3-B	R19IB3S-SPM1-B	W22IB3S-SPA3-B
	1 x Power Button 1 x Adjust up button 1 x Adjust down button 1 x ESC (Auto) button 1 x OK (Menu) button	1 x Power Button 1 x Adjust up button 1 x Adjust down button 1 x ESC (Auto) button 1 x OK (Menu) button	1 x Power Button 1 x Adjust up button 1 x Adjust down button 1 x ESC (Auto) button 1 x OK (Menu) button	1 x Power Button 1 x Adjust up button 1 x Adjust down button 1 x ESC (Auto) button 1 x OK (Menu) button
	Front side: 1 x Emergency Button & 3 x Flat Button for CN1 & CN2 M12 connector	Front side: 1 x Emergency Button & 3 x Flat Button for CN1 & CN2 M12 connector	Front side: 1 x Emergency Button & 3 x Flat Button for CN1 & CN2 M12 connector	Front side: 1 x Emergency Button & 3 x Flat Button for CN1 & CN2 M12 connector
LED Indicators	1 x LED Indicator for power 1 x LED Indicator for status	1 x LED Indicator for power 1 x LED Indicator for status	1 x LED Indicator for power 1 x LED Indicator for status	1 x LED Indicator for power 1 x LED Indicator for status
Power Management				
Power Input	Default 12V DC input 9~36V DC input for optional	Default 12V DC input 9~36V DC input for optional	Default 12V DC input 9~36V DC input for optional	Default 12V DC input 9~36V DC input for optional
Power Consumption	26 W (typ.)	30 W (typ.)	36 W (typ.)	50 W (typ.)
AC Adapter	100~240V AC to DC Adapter with waterproof connector	100~240V AC to DC Adapter with waterproof connector	100~240V AC to DC Adapter with waterproof connector	100~240V AC to DC Adapter with waterproof connector
Mechanical Specification				
Dimensions	293 x 250 x 69 mm	426 x 301 x 69 mm	516 x 395 x 69 mm	595 x 337 x 69 mm
Housing	Stainless steel SUS 316/ AISI 316	Stainless steel SUS 316/ AISI 316	Stainless steel SUS 316/ AISI 316	Stainless steel SUS 316/ AISI 316
Mounting	VESA mount (100x100mm)/ Yoke Mount(Optional)	VESA mount (100x100mm)/ Yoke Mount(Optional)	VESA mount (100x100mm)/ Yoke Mount(Optional)	VESA mount (100x100mm)/ Yoke Mount(Optional)
Environmental Consideration				
Operating Temperature	0 °C to 45 °C	0 °C to 45 °C	0 °C to 45 °C	0 °C to 45 °C
Storage Temperature	-20 °C to 60 °C	-20 °C to 60 °C	-20 °C to 60 °C	-20 °C to 60 °C
Operating Humidity	10% to 90% (non-condensing)	10% to 90% (non-condensing)	10% to 90% (non-condensing)	10% to 90% (non-condensing)
IP Rating	Full IP65	Full IP65	Full IP65	Full IP65
Standards and Certification				
EMC	CE, FCC	CE, FCC	CE, FCC	CE, FCC

NOTE:

- Accessories and Integrated Options may vary depending on your configuration. The product shown in this document is a standard model. For diagrams that contain customized or optional I/O, please contact the Winmate Sales Team for more information.
- All specifications are subject to change without prior notice.

Appendix B: Winmate Software Development Kit

Winnate provides the following SDK and Utilities for the IP65 Stainless B Series Panel PC.

Item	File Type	Description
1	SDK	Watchdog SDK
2	Utility	Watchdog Utility

To find the Drivers and SDK, please refer to the Driver CD that comes in the package or contact us. Also, you can download drivers from Winnate Download Center.

Winmate Inc.
9F, No.111-6, Shing-De Rd., San-Chung District,
New Taipei City 24158, Taiwan, R.O.C
www.winmate.com

Copyright © 2022 Winmate Inc. All rights reserved.

