

**AGS100 /
AGS100T /
AGS102 /
AGS102T**

**Advanced Gateway &
Ultra-Compact Fanless System**

User's Manual

Version 1.3
(Apr. 2020)



Copyright

© 2020 IBASE Technology, Inc. All rights reserved.

No part of this publication may be reproduced, copied, stored in a retrieval system, translated into any language or transmitted in any form or by any means, electronic, mechanical, photocopying, or otherwise, without the prior written consent of IBASE Technology, Inc. (hereinafter referred to as "IBASE").

Disclaimer

IBASE reserves the right to make changes and improvements to the products described in this document without prior notice. Every effort has been made to ensure the information in the document is correct; however, IBASE does not guarantee this document is error-free. IBASE assumes no liability for incidental or consequential damages arising from misapplication or inability to use the product or the information contained herein, nor for any infringements of rights of third parties, which may result from its use.

Trademarks

All the trademarks, registrations and brands mentioned herein are used for identification purposes only and may be trademarks and/or registered trademarks of their respective owners.

Compliance

CE

This product has passed CE tests for environmental specifications and limits. This product is in accordance with the directives of the Union European (EU). If users modify and/or install other devices in this equipment, the CE conformity declaration may no longer apply.

FCC

This product has been tested and found to comply with the limits for a Class B device, pursuant to Part 15 of the FCC Rules. These limits are designed to provide reasonable protection against harmful interference in a residential installation. This equipment generates, uses and can radiate radio frequency energy and, if not installed and used in accordance with manufacturer's instructions, may cause harmful interference to radio communications.

WEEE



This product must not be disposed of as normal household waste, in accordance with the EU directive of for waste electrical and electronic equipment (WEEE - 2012/19/EU). Instead, it should be disposed of by returning it to a municipal recycling collection point. Check local regulations for disposal of electronic products.

Green IBASE



This product is compliant with the current RoHS restrictions and prohibits use of the following substances in concentrations exceeding 0.1% by weight (1000 ppm) except for cadmium, limited to 0.01% by weight (100 ppm).

- Lead (Pb)
- Mercury (Hg)
- Cadmium (Cd)
- Hexavalent chromium (Cr6+)
- Polybrominated biphenyls (PBB)
- Polybrominated diphenyl ether (PBDE)

Important Safety Information

Carefully read the precautions before using the device.

Environmental conditions:

- Lay the device horizontally on a stable and solid surface in case the device may fall, causing serious damage.
- Make sure you leave plenty of space around the device for ventilation.
- Use this product in environments with ambient temperatures $-40^{\circ}\text{C} \sim 70^{\circ}\text{C}$ for E-series CPU and $-20^{\circ}\text{C} \sim 60^{\circ}\text{C}$ for N-series CPU.
- Do not leave this device in an environment where the storage temperature may go below -40°C or above 85°C . This could damage the device. The device must be used in a controlled environment.

Care for your iBASE products:

- Before cleaning the device, turn it off and unplug all cables such as power in case a small amount of electrical current may still flow.
- Use neutral cleaning agents or diluted alcohol to clean the device chassis with a cloth. Then wipe the chassis with a dry cloth.
- Vacuum the dust with a computer vacuum cleaner to prevent the air vent or slots from being clogged.



WARNING

Attention during use:

- Do not use this product near water.
- Do not spill water or any other liquids on your device.
- Do not place heavy objects on the top of the device.
- Operate this device from the type of power indicated on the marking label. If you are not sure of the type of power available, consult your distributor or local power company.
- Ensure that you apply correctly the power supply voltage.
- Do not walk on the power cord or allow anything to rest on it.
- If you use an extension cord, make sure that the total ampere rating of the product plugged into the extension cord does not exceed its limits.

Avoid Disassembly

You are not suggested to disassemble, repair or make any modification to the device. Disassembly, modification, or any attempt at repair could generate hazards and cause damage to the device, even bodily injury or property damage, and will void any warranty.



CAUTION

Replace only with the same or equivalent type recommended by the manufacturer. Dispose of used batteries according to the manufacturer's instructions.

Warranty Policy

- **IBASE standard products:**

24-month (2-year) warranty from the date of shipment. If the date of shipment cannot be ascertained, the product serial numbers can be used to determine the approximate shipping date.

- **3rd-party parts:**

12-month (1-year) warranty from delivery for the 3rd-party parts that are not manufactured by IBASE, such as CPU, memory, storage device, power adapter, panel and touchscreen.

* PRODUCTS, HOWEVER, THAT FAILS DUE TO MISUSE, ACCIDENT, IMPROPER INSTALLATION OR UNAUTHORIZED REPAIR SHALL BE TREATED AS OUT OF WARRANTY AND CUSTOMERS SHALL BE BILLED FOR REPAIR AND SHIPPING CHARGES.

Technical Support & Services

1. Visit the IBASE website at www.ibase.com.tw to find the latest information about the product.
2. If you need any further assistance from your distributor or sales representative, prepare the following information of your product and elaborate upon the problem.
 - Product model name
 - Product serial number
 - Detailed description of the problem
 - The error messages in text or in screenshots if there is any
 - The arrangement of the peripherals
 - Software in use (such as OS and application software, including the version numbers)
3. If repair service is required, you can download the RMA form at <http://www.ibase.com.tw/english/Supports/RMAService/>. Fill out the form and contact your distributor or sales representative.

Table of Contents

Chapter 1	General Information	1
1.1	Introduction.....	2
1.2	Features	2
1.3	Packing List	3
1.4	Optional Accessories.....	3
1.5	Specifications	4
1.6	Overview – AGS100	6
1.7	Overview – AGS100T.....	8
1.8	Overview – AGS102.....	10
1.9	Overview – AGS102T.....	12
1.10	Dimensions – AGS100 / AGS100T.....	14
1.11	Dimensions – AGS102 / AGS102T.....	14
Chapter 2	Hardware Configuration	15
2.1	Installations	16
2.1.1	Memory Installation / Replacement	16
2.1.2	Mini-PCIe & M.2 Cards Installation / Replacement.....	17
2.1.3	WiFi / 3G / 4G Antenna Installation	17
2.1.4	Mounting Installation	18
2.1.5	Pinout for COM Ports, DC-In Power Connector & Line-Out Jack.....	20
2.2	Setting the Jumpers.....	23
2.3	Motherboard Jumper & Connector Locations	24
2.4	Motherboard Jumpers Quick Reference	26
2.4.1	Clearing ME Register (JP1).....	26
2.4.2	Clearing CMOS Data (JP2)	26
2.5	Motherboard Connectors Quick Reference.....	27
2.5.1	Battery Connector (BAT1)	28
2.5.2	Reset Button Connector (J1).....	28
2.5.3	Power Button Connector (J3)	28
2.5.4	Board-to-Board Connector (J11)	29
2.6	Carrier Board Connectors Quick Reference (for AGS102 / AGS102T only)	30

Chapter 3	Driver Installation	31
3.1	Introduction.....	32
3.2	Intel® Chipset Software Installation Utility	32
3.3	Graphics Driver Installation.....	34
3.4	HD Audio Driver Installation.....	36
3.5	Intel® Trusted Execution Engine Driver Installation.....	37
3.6	USB 3.1 Driver Installation.....	38
3.7	LAN Driver Installation.....	39
Chapter 4	BIOS Setup.....	41
4.1	Introduction.....	42
4.2	BIOS Setup	42
4.3	Main Settings.....	43
4.4	Advanced Settings.....	44
4.4.1	ACPI Settings.....	45
4.4.2	iSmart Controller	46
4.4.3	Fintek Super IO Configuration.....	47
4.4.4	Fintek Hardware Monitor	52
4.4.5	CPU Configuration	53
4.4.6	Network Stack Configuration.....	53
4.4.7	CSM Configuration.....	54
4.4.8	USB Configuration	55
4.5	Chipset Settings	56
4.5.1	HD-Audio Configuration	57
4.5.2	PCI Express Configuration.....	57
4.5.3	SATA Drives	59
4.5.4	USB Configuration	60
4.6	Security Settings.....	61
4.7	Boot Settings	62
4.8	Save & Exit Settings.....	63
Appendix.....	64
A.	I/O Port Address Map	65
B.	Interrupt Request Lines (IRQ).....	67
C.	Watchdog Timer Configuration	68

Chapter 1

General Information

The information provided in this chapter includes:

- Features
- Packing List
- Optional Accessories
- Specifications
- Overview
- Dimensions

1.1 Introduction

AGS100, AGS102, AGS100T, AGS102T are iBASE embedded computing systems designed for thin clients, smart industrial automation or controller, and retail equipment. It is based on Intel® Atom™ / Pentium® / Celeron® processors and features iSMART that allows auto-scheduling for general applications and energy savings. It has a wide-range operating temperature range from -40 to 70°C or -20 to 60°C (for N-series processor).



AGS100



AGS102



AGS100T



AGS102T

1.2 Features

- Ultra-Compact, rugged and fanless system with Intel® Atom™ E3950 / E3940 / E3930, Pentium® N4200 or Celeron® N3350 series processor
- Over/Under/Reverse voltage protection
- 9V~36V DC wide-range power input
- Display output through DisplayPort and DVI-I
- DIN-rail mount & Wall mount compatibility
- GPIO 4-in & 4-out with isolation function for AGS102 and AGS102T only
- iSmart for power management
- 1 x mini-PCle

1.3 Packing List

Your product package should include the items listed below. If any of the items below is missing, contact the distributor or the dealer from whom you purchased the product.

- AGS100 / AGS102 / AGS100T/ AGS102T x 1
- Power Cord
- Wall Mount Kit x 1
- Round Head Screw (for Wall Mount Kit) x 4
- Terminal Block for DC-In Power Adapter (3 pins) x 1
- Thermal Pad
 - 19 x 19 x 2 mm x 1
 - 28 x 18 x 2 mm x 1
- Disk (including drivers and this user manual) x 1

1.4 Optional Accessories

IBASE provide optional accessories as follows. Please contact us or your dealer if you need any.

- DC-In Power Adapter
- Power Cord
- WiFi Antenna Kit
- 4G/LTE or GPS Antenna Kit
- DIN Rail Bracket

1.5 Specifications

Product Name	AGS100	AGS102	AGS100T	AGS102T
System				
Motherboard	IB801		IB802T	
Carrier Board	N/A	IP801	N/A	IP801
Operating System	<ul style="list-style-type: none"> Windows10 (64-bit) Linux Ubuntu 			
CPU	Intel® Atom™ E3950 / E3940 / E3930, Pentium® N4200, Celeron® N3350 / E3940 Series			
CPU Speed	Up to 2.5 GHz			
Memory	1 x DDR3-1866 SO-DIMM 4GB, expandable to 8 GB (Non-ECC)		1 x DDR3-1866/1600 SO-DIMM 4GB, expandable to 8 GB (Non-ECC)	
Storage	<ul style="list-style-type: none"> 1 slot for M.2 B3042 SSD 1 slot for mSATA 			
Super I/O	Fintek F81964D-I			
Audio Codec	Realtek ALC283		Realtek ALC269	
Network	For E-series CPU: Intel® I210IT GbE LAN For N-series CPU: Intel® I211AT GbE LAN			
Power Supply	DC-In 9 ~ 36V (3-pin terminal block)			
BIOS	AMI BIOS			
Watchdog	Watchdog Timer 256 segments, 0, 1, 2...255 sec/min			
TPM	N/A		2.0	
iSMART	Yes			
Chassis	Aluminum & steel, silver			
Mounting	<ul style="list-style-type: none"> Desktop mount / Wall mount (wall mount kit included) DIN rail mount (optional) 			
Dimensions (W x H x D)	160 x 44 x 110 mm (6.3" x 1.73" x 4.33")			
Weight	0.9 kg (1.98 lb)	1 kg (2.2 lb)	0.9 kg (1.98 lb)	1 kg (2.2 lb)
Certificate	CE / LVD / FCC Class B			
I/O Ports				
Left External I/O	<ul style="list-style-type: none"> 2 x RS232/422/485 port: COM1 & COM2, selectable from BIOS 1 x Antenna hole for WLAN module 1 x Speaker-out connector 			
Right External	1 x Nano SIM card slot			

I/O	* The socket signal is from the M.2 B3042 4G/LTE card.
Rear External I/O	<ul style="list-style-type: none"> • 1 x DVI-I • 1 x DisplayPort • 4 x USB 3.0 • 2 x RJ45 GbE LAN port • 3 x LED indicators (HDD, WLAN, WWAN) • 1 x power button with LED (Green for AGS100 / AGS102, and blue for AGS100T / AGS102T) • 1 x 3-pins DC-in terminal block type for 9-36V • 1 x Antenna hole for WLAN module • 2 x RS-232 port: COM3 & COM4 (for AGS102 only) • 2 x RS-232/422/485 port: COM3 & COM4 (for AGS102T only) • 1 x USB 2.0 port (for AGS102 & AGS102T only) • 1 x Isolated 4-In & 4-Out GPIO connector (for AGS102 & AGS102T only) • LED indicators: Red for HDD, Blue for WLAN, Yellow for WWAN
Expansion slots	<ul style="list-style-type: none"> • 1 x full-size Mini-PCIe socket with USB 2.0 & PCIe & SATA • 1 x M.2 E2230 socket with USB 2.0 & PCIe for WLAN & BT • 1 x M.2 B3042 socket with USB 2.0 & SATA for WWAN & SSD
Environment	
Temperature	<ul style="list-style-type: none"> • Operating: For E-series CPU: -40 ~ 70 °C (-40 ~ 158 °F) For N-series CPU: -20 ~ 60 °C (-4 ~ 140 °F) • Storage: -40~ 85 °C (-40 ~ 185 °F)
Relative Humidity	5 ~ 90% at 45 °C (non-condensing)
Vibration	With IEC 60068-2-64 <ul style="list-style-type: none"> • Operating: 2 Grms / 5 ~ 500 Hz (Random operation) • Non-operating: 3 Grms / 5 ~ 500Hz (Random operation)
Shock	With MIL-STD-810G <ul style="list-style-type: none"> • Operating: 30 g / 11 ms duration • Non-operating: 40 g / 11 ms duration

All specifications are subject to change without prior notice.

1.6 Overview – AGS100

Front View

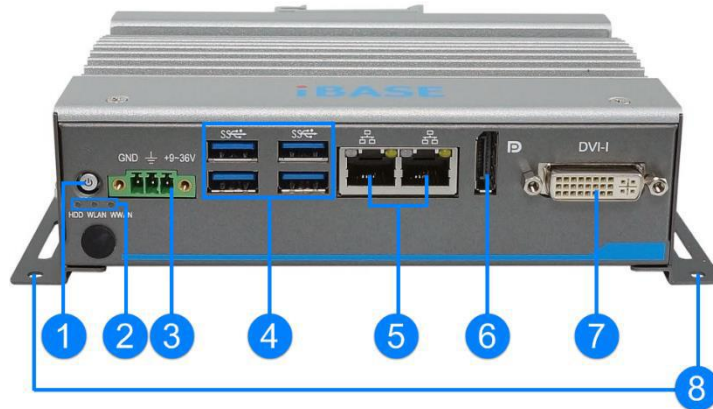

Side View



No.	Name	No.	Name
1	Power Button (Silver for AGS100)	7	DVI-I Port
2	LED Indicatorss (Red for HDD, Blue for WLAN, Yellow for WWAN)	8	Wall Mount Kit
3	DC-In Power Connector (3 pins)	9	Antenna Holes
4	USB 3.0 Ports	10	Audio Line-Out Jack (supports 2W mono speaker)
5	GbE LAN Ports	11	COM1 & COM2 RS-232/422/485 Ports
6	DisplayPort	12	Nano SIM Slot Door

Wall Mount



DIN Rail Mount (Optional)

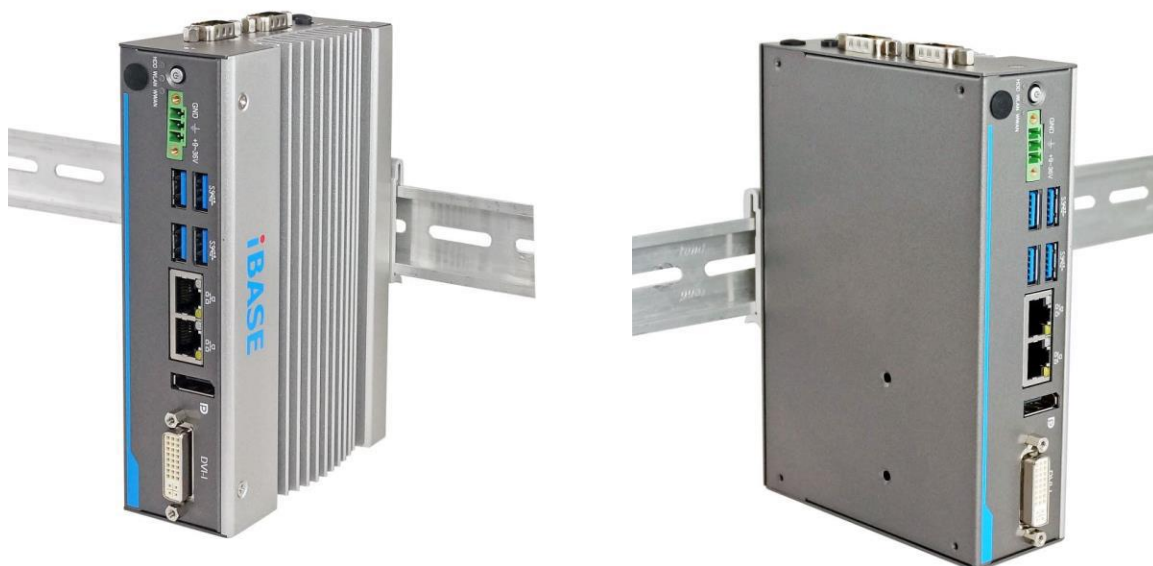

1.7 Overview – AGS100T

Front View

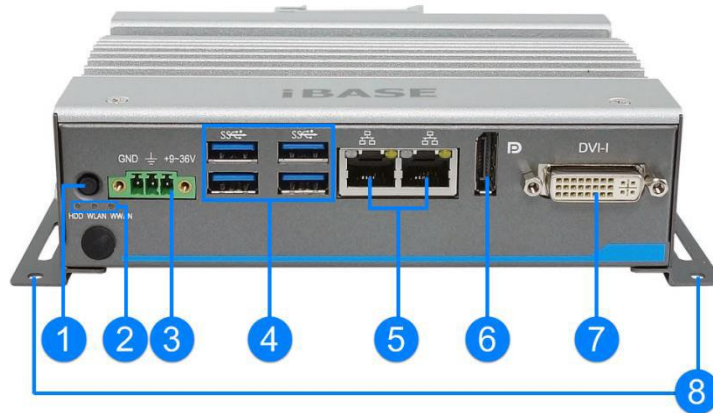

Side View



No.	Name	No.	Name
1	Power Button (Black for AGS100T)	7	DVI-I Port
2	LED Indicatorss (Red for HDD, Blue for WLAN, Yellow for WWAN)	8	Wall Mount Kit
3	DC-In Power Connector (3 pins)	9	Antenna Holes
4	USB 3.0 Ports	10	Audio Line-Out Jack (supports stereo output)
5	GbE LAN Ports	11	COM1 & COM2 RS-232/422/485 Ports
6	DisplayPort	12	Nano SIM Slot Door

Wall Mount



DIN Rail Mount (Optional)



1.8 Overview – AGS102

Front View

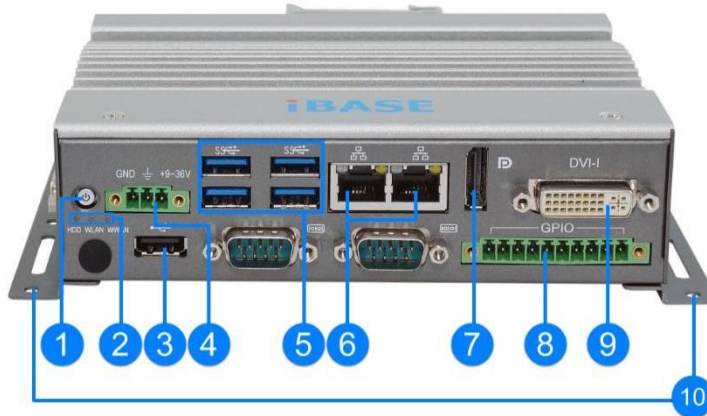

Rear View

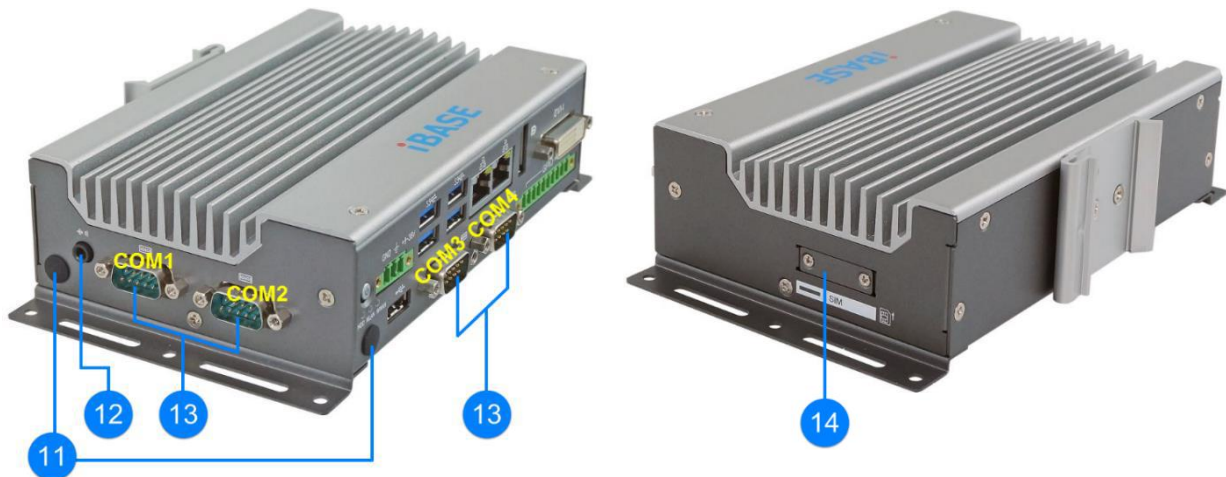

No.	Name	No.	Name
1	Power Button (Silver for AGS102)	8	GPIO Port
2	LED Indicatorss (Red for HDD, Blue for WLAN, Yellow for WWAN)	9	DVI-I Port
3	USB 2.0 Port	10	Wall Mount Kit
4	DC-In Power Connector (3 pins)	11	Antenna Holes
5	USB 3.0 Ports	12	Audio Line-Out Jack (supports 2W mono speaker)
6	GbE LAN Ports	13	COM1 ~ COM4 Ports (COM1 & COM2 RS-232/422/485, COM3 & COM4 RS-232 Ports)
7	DisplayPort	14	Nano SIM Slot Door

Wall Mount



DIN Rail Mount (Optional)



1.9 Overview – AGS102T

Front View

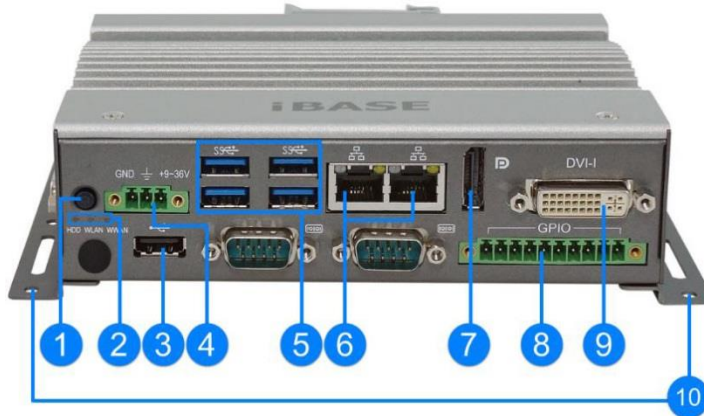

Rear View

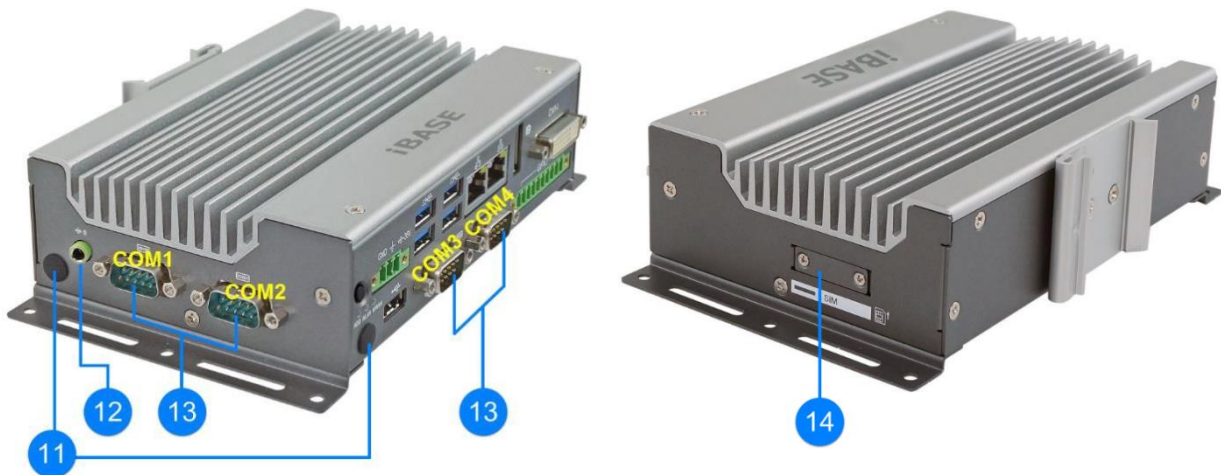

No.	Name	No.	Name
1	Power Button (Black for AGS102T)	8	GPIO Port
2	LED Indicatorss (Red for HDD, Blue for WLAN, Yellow for WWAN)	9	DVI-I Port
3	USB 2.0 Port	10	Wall Mount Kit
4	DC-In Power Connector (3 pins)	11	Antenna Holes
5	USB 3.0 Ports	12	Audio Line-Out Jack (supports stereo output)
6	GbE LAN Ports	13	COM1 ~ COM4 Ports (RS-232/422/485)
7	DisplayPort	14	Nano SIM Slot Door

Wall Mount



DIN Rail Mount (Optional)



1.10 Dimensions – AGS100 / AGS100T

Unit: mm

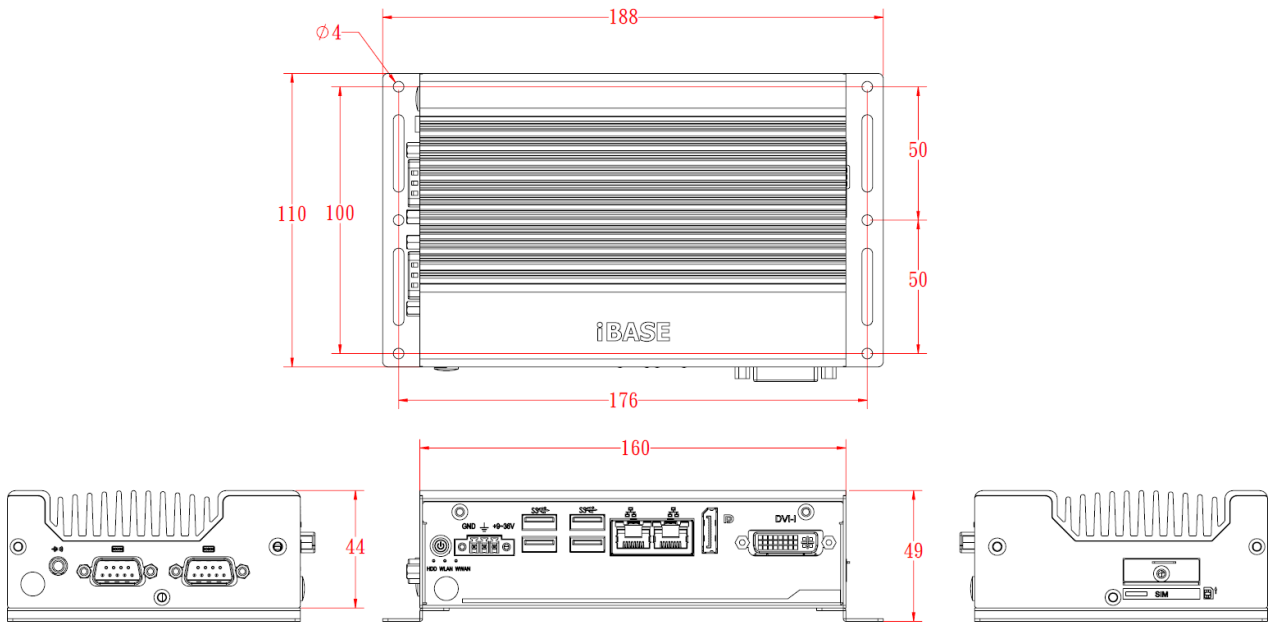

1.11 Dimensions – AGS102 / AGS102T

Unit: mm

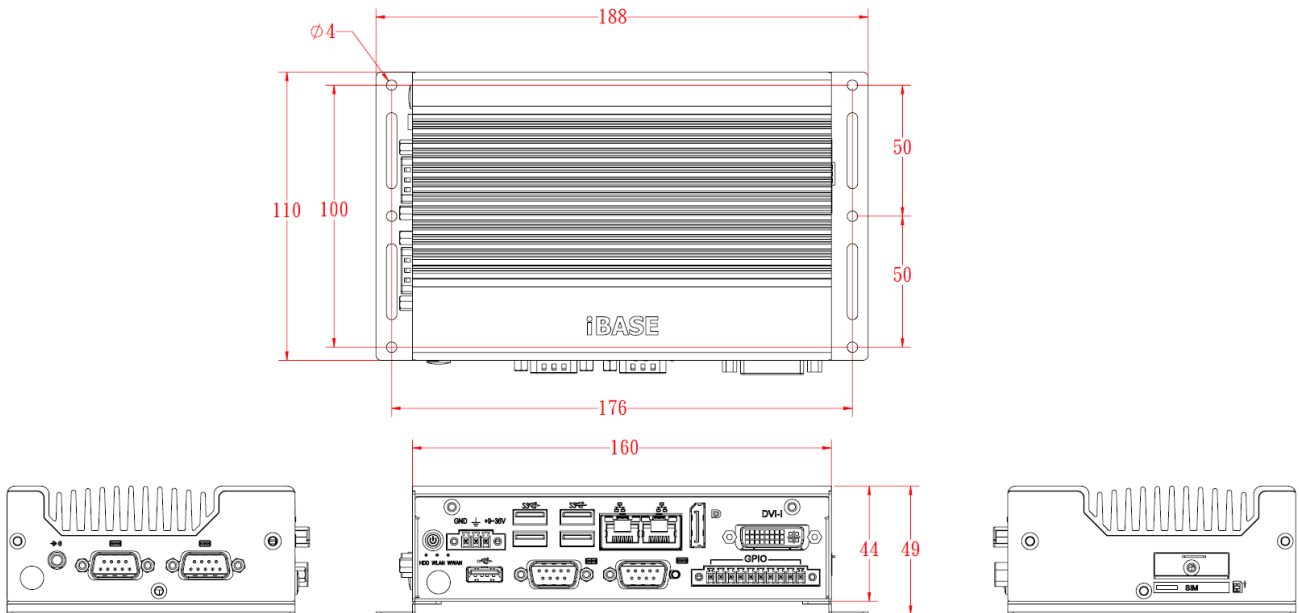

Chapter 2

Hardware Configuration

The information provided in this chapter includes:

- Installations
- Information and locations of connectors

2.1 Installations

Turn your product upside down and take away the device bottom cover by removing 6 screws as indicated below for the installation or replacement of the memory module, mSATA SSD or WLAN card. After installations, secure the device bottom cover back.

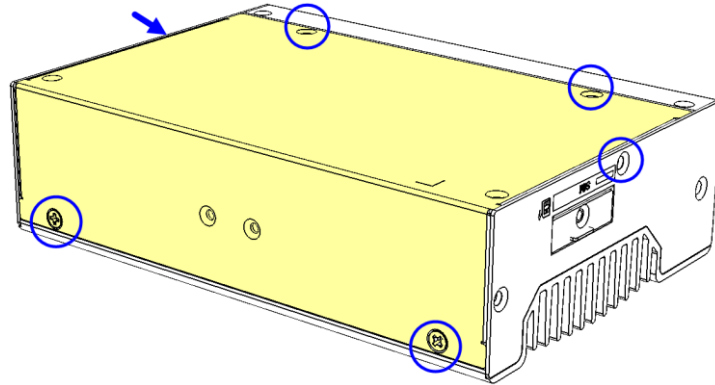

2.1.1 Memory Installation / Replacement

If you need to install or replace a memory module, follow the instructions below for installation after you disassemble the device cover.

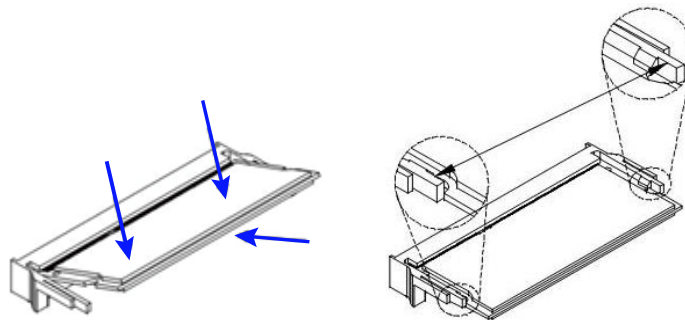

1. Align the key of the memory module with that on the memory slot and insert the module slantwise.
2. Gently push the module in an upright position until the clips of the slot close to hold the module in place when the module touches the bottom of the slot.

To remove the module, press the clips outwards with both hands, and the module will pop-up.

2.1.2 Mini-PCle & M.2 Cards Installation / Replacement

After removing the bottom cover, follow the instructions below.

1. Locate the mini-PCle or M.2 slot, align the key of the card to the interface, and insert the card slantwise.

Mini-PCle card:

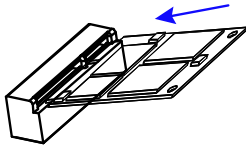

M.2 card:

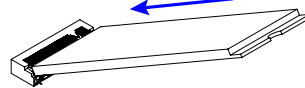

2. Push the card down and fix it with the supplied 2 flat head screws for the mini-PCle card and with one screw for M.2 card.

Mini-PCle card:

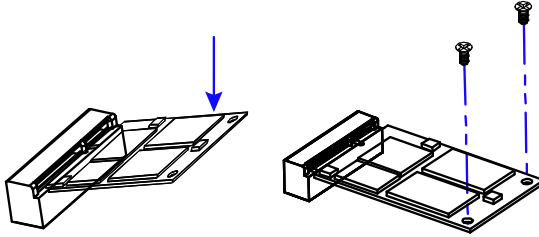

M.2 card:

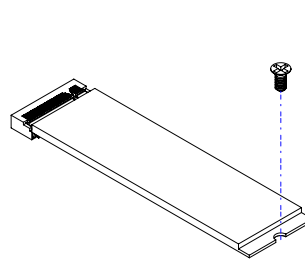

2.1.3 WiFi / 3G / 4G Antenna Installation

Thread the WiFi / 3G / 4G antenna extension cable through an antenna hole of the front I/O cover and fasten the antenna as shown below. Then apply adhesive to the edge of the hex nut behind the front I/O cover to prevent the extension cable from falling if the cable becomes loose.

1. Thread and fasten the hex nut and the washer. Then install the antenna.
2. Apply adhesive around here.



Info: The diameter of the nut is around 6.35 mm (0.25"-36UNC).

2.1.4 Mounting Installation

Requirements

Before mounting the system, ensure that you have enough room for power and signal cable routing, and have good ventilation for the power adaptor. The method of mounting must be able to support the weight of the device plus the weight of the suspending cables to be attached to the system. Use the following methods for mounting your system:

2.1.4.1. Wall-Mounting Installation

1. Turn your product upside down to attach the mounting brackets to your product and secure with the supplied 4 screws.

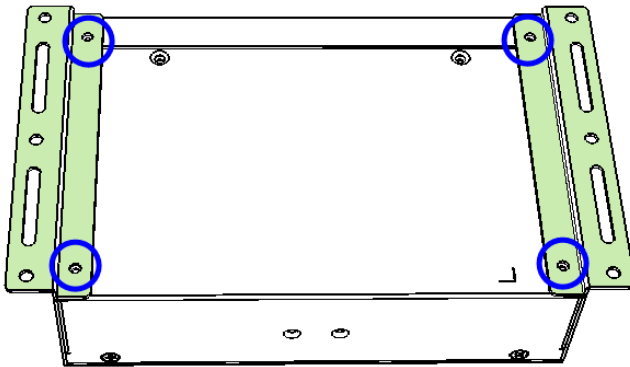

2. Prepare at least 4 screws (M3) to install the device on wall.

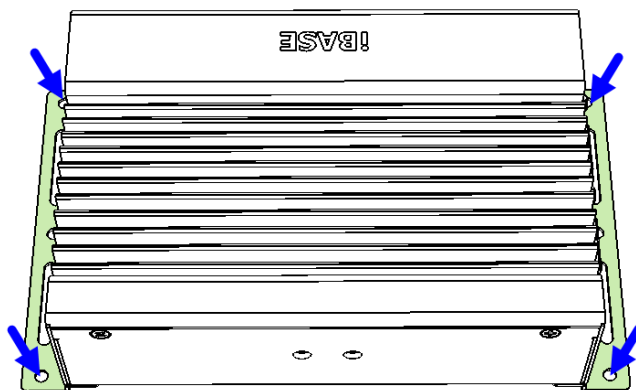

2.1.4.2. DIN Rail Mounting Installation (Optional)

1. Attach the DIN rail mounting bracket to your product, and secure with the supplied 2 screws.

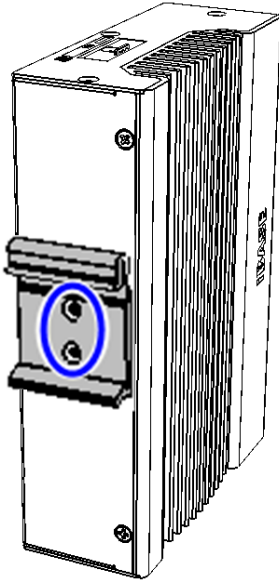

2. Hook the DIN rail mounting bracket over the top of the DIN rail, and then press the lower section of the bracket towards the DIN rail to clip the bracket onto it.

2.1.5 Pinout for COM Ports, DC-In Power Connector & Line-Out Jack

2.1.5.1. COM1 & COM2 RS232/422/485 Ports

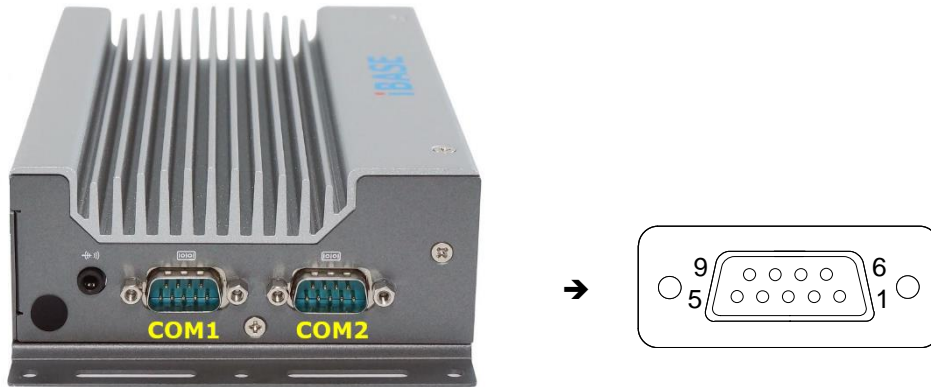

COM1 and COM2 ports are jumper-less and configurable in BIOS.

Pin	Assignment		
	RS-232	RS-422	RS-485
1	DCD, Data carrier detect	TX-	DATA-
2	RXD, Receive data	TX+	DATA+
3	TXD, Transmit data	RX+	NC
4	DTR, Data terminal ready	RX-	NC
5	Ground	Ground	Ground
6	DSR, Data set ready	NC	NC
7	RTS, Request to send	NC	NC
8	CTS, Clear to send	NC	NC
9	RI, Ring indicator	NC	NC

2.1.5.2. COM3 & COM4 Port (for AGS102 & AGS102T only)

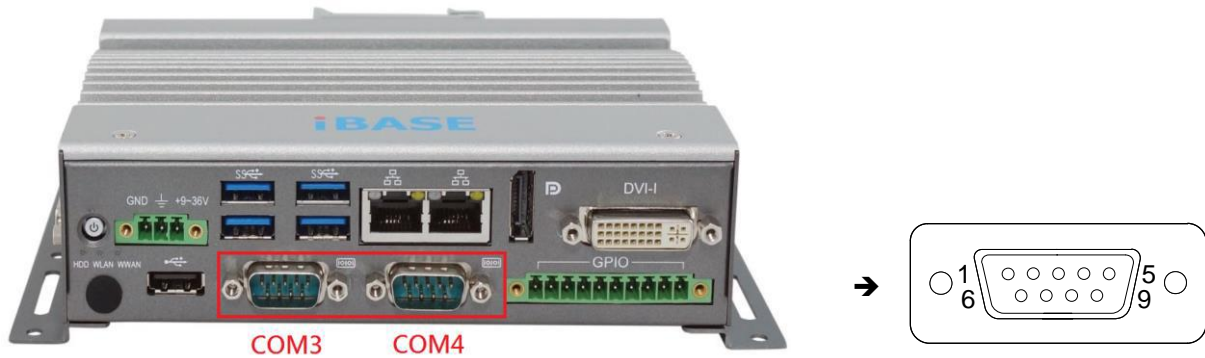

COM3 and COM4 are both available for AGS102 / AGS102T only.

RS-232 for **AGS102**:

Pin	Assignment	Pin	Assignment
1	DCD, Data carrier detect	6	DSR, Data set ready
2	RXD, Receive data	7	RTS, Request to send
3	TXD, Transmit data	8	CTS, Clear to send
4	DTR, Data terminal ready	9	RI, Ring indicator
5	Ground		

RS-232/422/485 for **AGS102T**:

Pin	Assignment		
	RS-232	RS-422	RS-485
1	DCD	TX-	DATA-
2	RX	TX+	DATA+
3	TX	RX+	NC
4	DTR	RX-	NC
5	Ground	Ground	Ground
6	DSR	NC	NC
7	RTS	NC	NC
8	CTS	NC	NC
9	RI	NC	NC

2.1.5.3. DC-In Power Connector (3-pin terminal block)

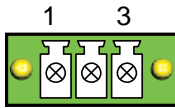

Pin	Assignment	Pin	Assignment
1	Power Ground	3	9V ~ 36V
2	Case Ground		

2.1.5.4. Isolated 4-In & 4-Out GPIO Connector (10-pin terminal block)



Pin	Assignment	Pin	Assignment
1	Isolation +5V	6	OUT0
2	IN0	7	OUT1
3	IN1	8	OUT2
4	IN3	9	OUT3
5	IN4	10	Isolation Ground

2.1.5.5. Audio Line-Out Jack for **AGS100(T)** & **AGS102(T)**



AGS100 and **AGS102** support 2W mono speaker. Please see diagram below. (**AGS100T** and **AGS102T** support stereo output.)

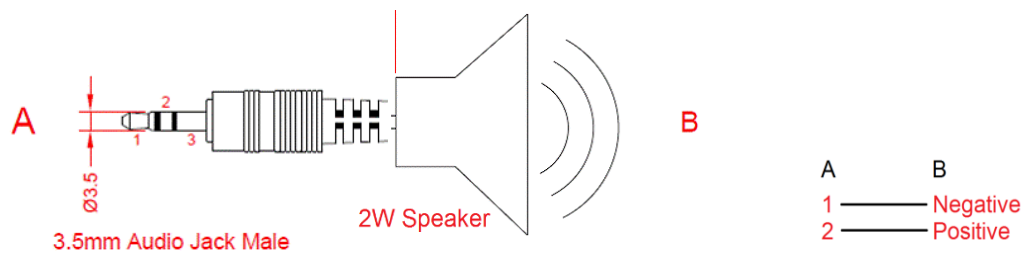

2.2 Setting the Jumpers

Set up and configure your device by using jumpers for various settings and features according to your needs and applications. Contact your supplier if you have doubts about the best configuration for your use.

2.2.1 How to Set Jumpers

Jumpers are short-length conductors consisting of several metal pins with a non-conductive base mounted on the circuit board. Jumper caps are used to have the functions and features enabled or disabled. If a jumper has 3 pins, you can connect either PIN1 to PIN2 or PIN2 to PIN3 by shorting.

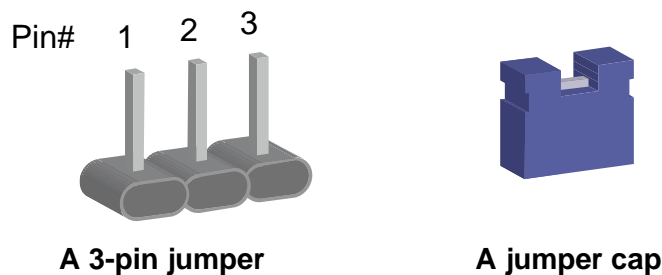

Refer to the illustration below to set jumpers.

Pin closed	Oblique view	Illustration in the manual
Open		
1-2		
2-3		

When two pins of a jumper are encased in a jumper cap, this jumper is **closed**, i.e. turned **On**.

When a jumper cap is removed from two jumper pins, this jumper is **open**, i.e. turned **Off**.

2.3 Motherboard Jumper & Connector Locations

Motherboard: IB801 / IB802T

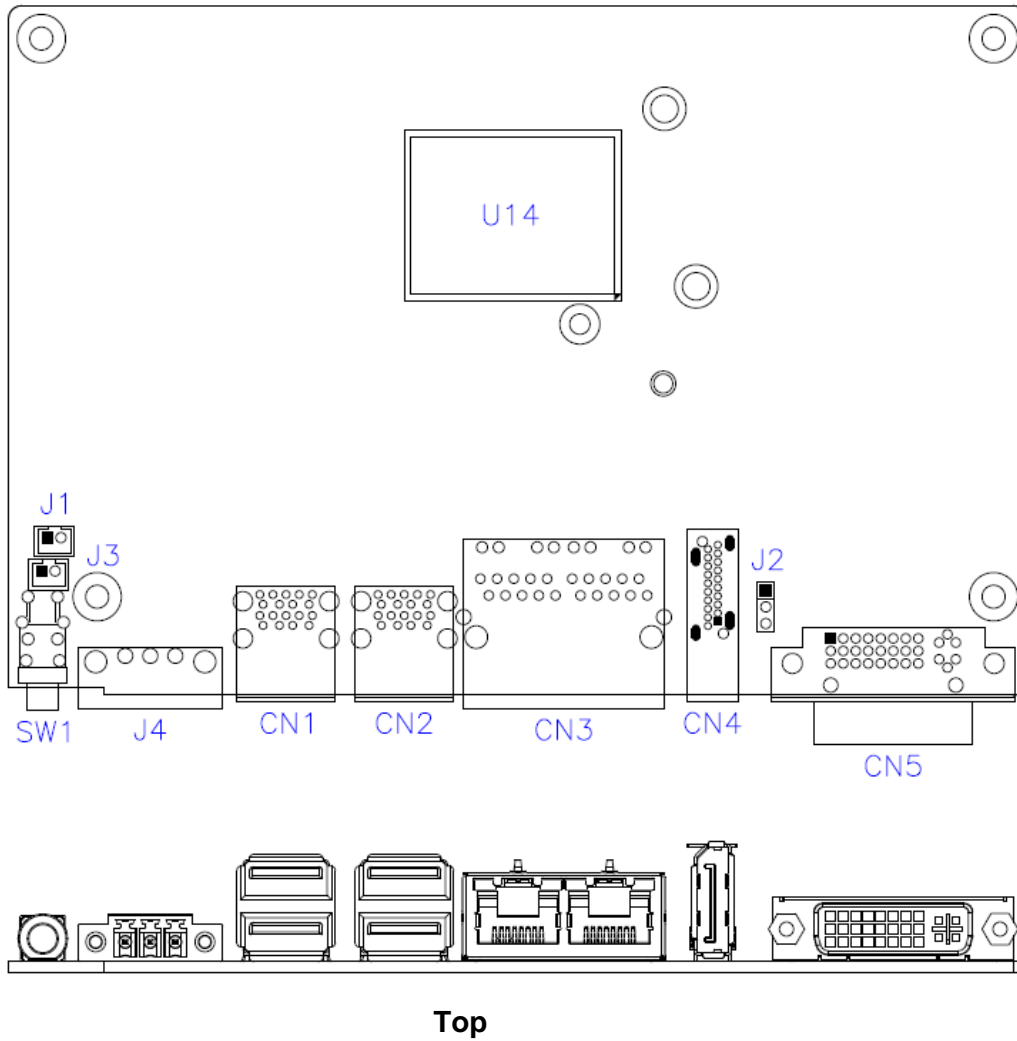

2 Hardware Configuration

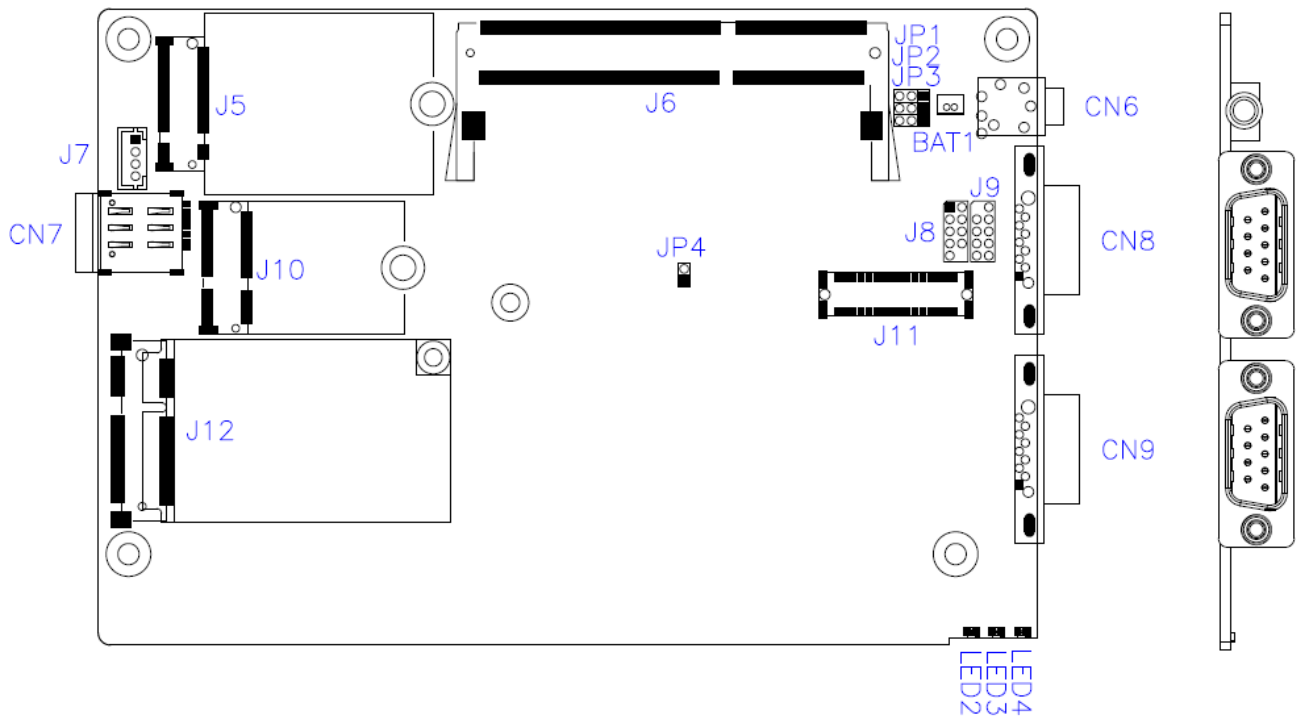

Bottom

2.4 Motherboard Jumpers Quick Reference

Function	Connector Name	Page
Clearing ME Register	JP1	26
Clearing CMOS Data	JP2	26
Factory Use Only	JP4,	--

2.4.1 Clearing ME Register (JP1)

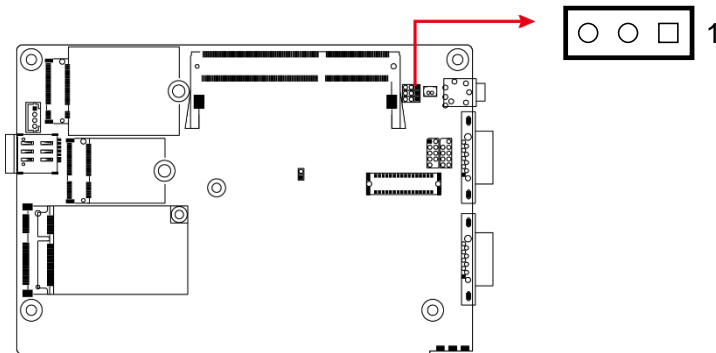

Function	Pin closed	Illustration
Normal (default)	1-2	1
Clear ME Register	2-3	1

2.4.2 Clearing CMOS Data (JP2)

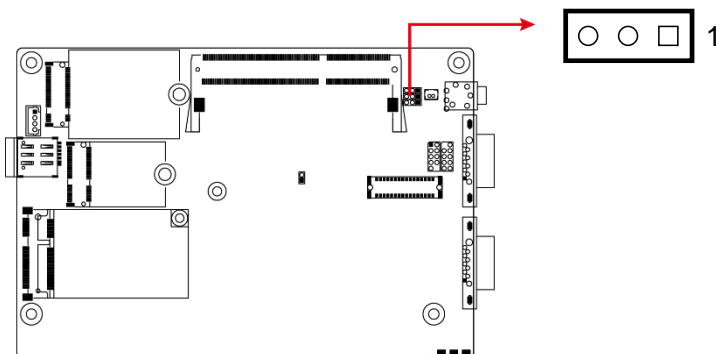

Function	Pin closed	Illustration
Normal (default)	1-2	1
Clear CMOS	2-3	1

2.5 Motherboard Connectors Quick Reference

Motherboard: IB801 / IB802T

Function	Connector Name	Page
Battery Connector	BAT1	28
Reset Button Connector	J1	28
Power Button Connector	J3	28
Board-to-Board Connector	J11	29
Power Button	SW1	--
USB 3.0 Port	CN1, CN2	--
Dual GbE LAN Port	CN3	--
DisplayPort	CN4	--
DVI-I Port	CN5	--
Audio Line-Out Jack	CN6	--
Nano SIM Card Slot	CN7	--
COM1 & COM2 RS-232/422/485 Port ^[1]	CN8 (COM1), CN9 (COM2)	--
DC-In Power Connector ^[2]	J4	--
M.2 B3042	J5	--
DDR3L Memory Slot	J6	--
M.2 E2230 Slot	J10	--
Mini-PCIe Slot	J12	--
LED Indicators	LED2 (for M.2 B3042), LED3 (for WLAN), LED4 (for HDD)	--
Factory Use Only	J2, J7, J8, J9	--

[1], [2]: Refer to 2.1.5 Pinout for COM Ports, DC-In Power Connector.

2.5.1 Battery Connector (BAT1)

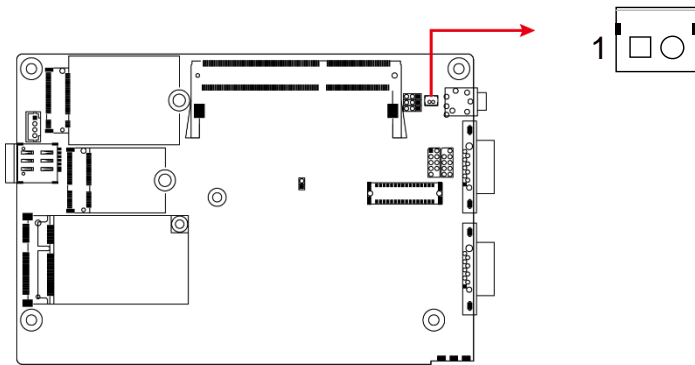

Pin	Assignment	Pin	Assignment
1	Battery+	2	Ground

2.5.2 Reset Button Connector (J1)

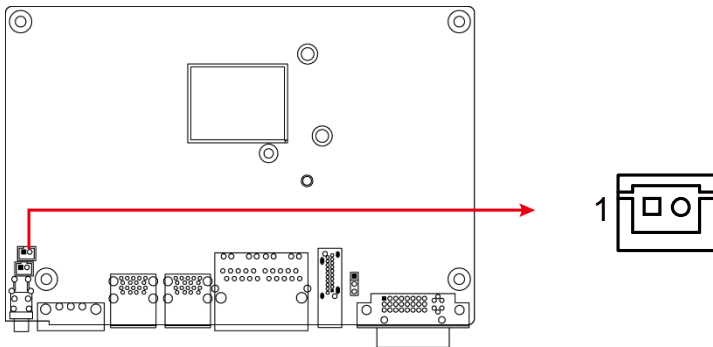

Pin	Assignment	Pin	Assignment
1	Ground	2	Reset BTN

2.5.3 Power Button Connector (J3)

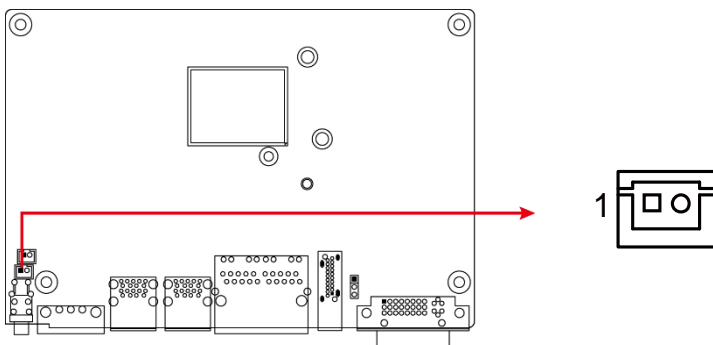

Pin	Assignment	Pin	Assignment
1	Ground	2	Power BTN

2.5.4 Board-to-Board Connector (J11)

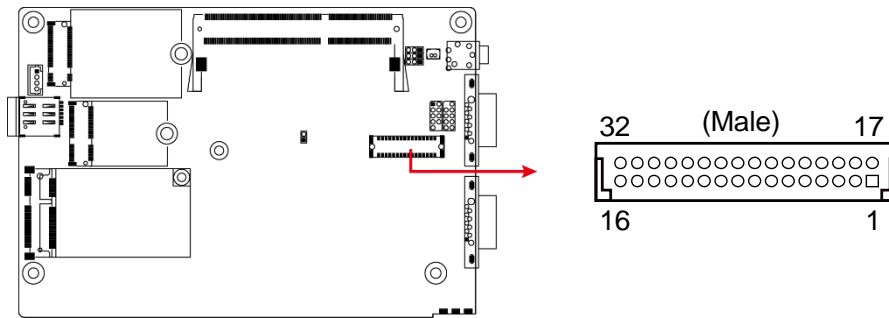

Pin	Assignment	Pin	Assignment
1	Ground	17	VCC5
2	GPIO_IN0	18	VCC5
3	GPIO_IN1	19	GPIO_OUT0
4	GPIO_IN3	20	GPIO_OUT1
5	GPIO_IN4	21	GPIO_OUT2
6	(COM3) DSR, Data set ready	22	GPIO_OUT3
7	(COM3) RTS, Request to send	23	(COM3) DCD, Data carrier detect
8	(COM3) CTS, Clear to send	24	(COM3) RXD, Receive data
9	(COM3) RI, Ring indicator	25	(COM3) TXD, Transmit data
10	(COM4) DSR, Data set ready	26	(COM3) DTR, Data terminal ready
11	(COM4) RTS, Request to send	27	(COM4) DCD, Data carrier detect
12	(COM4) CTS, Clear to send	28	(COM4) RXD, Receive data
13	(COM4) RI, Ring indicator	29	(COM4) TXD, Transmit data
14	USB_D+	30	(COM4) DTR, Data terminal ready
15	USB_D-	31	Ground
16	Ground	32	5VDUAL

2.6 Carrier Board Connectors Quick Reference (for AGS102 / AGS102T only)

Carrier Board: IP801

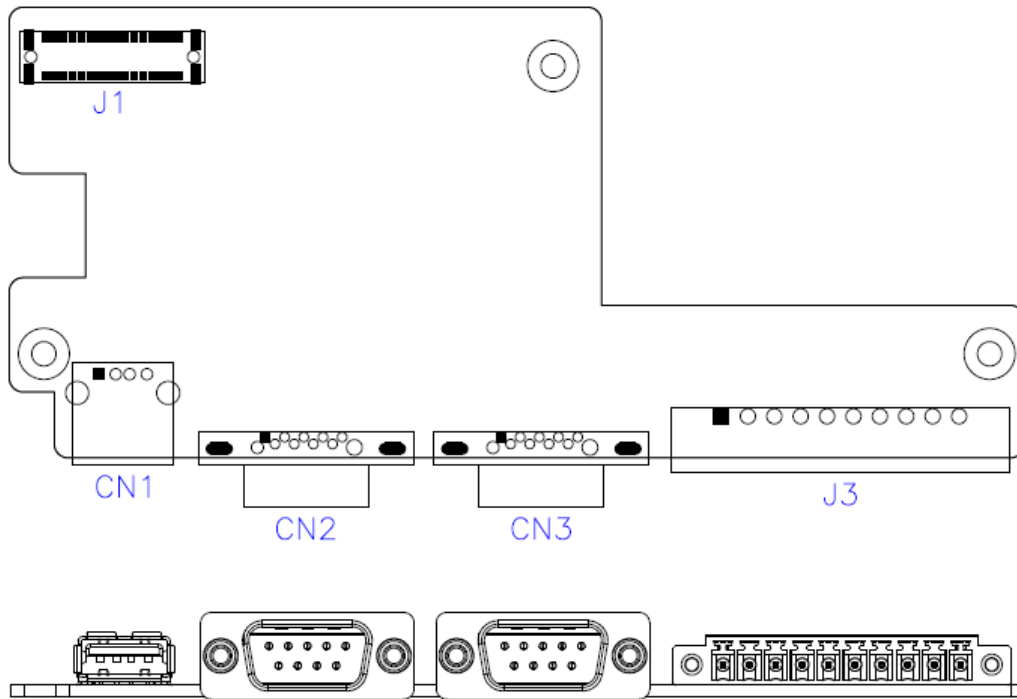

IP801 - Top

Function	Connector Name
COM3 & COM4 Port ^[1]	CN2 (COM3), CN3 (COM4)
Isolated 4-In & 4-Out GPIO Connector ^[2]	J3
Board-to-Board Connector ^[3]	J1
USB 2.0 Port	CN1

[1]: Refer to 2.1.5.2 COM3 & COM4 Port (for AGS102 & AGS102T only).

[2]: Refer to 2.1.5.4 Isolated 4-In & 4-Out GPIO Connector (10-pin terminal block).

[3]: Refer to 2.5.4 Board-to-Board Connector (J11) for the pinout.

Chapter 3

Driver Installation

The information provided in this chapter includes:

- Intel® Chipset Software Installation Utility
- Graphics Driver Installation
- HD Audio Driver Installation
- Intel® Trusted Execution Engine Drivers Installation
- Intel® Serial I/O Drivers
- LAN Driver Installation

3.1 Introduction

This section describes the installation procedures for software drivers. The software drivers are in a disk enclosed with the product package. If you find anything missing, please contact the distributor where you made the purchase.

Note: After installing your Windows operating system, you must install the Intel® Chipset Software Installation Utility first before proceeding with the drivers installation.

3.2 Intel® Chipset Software Installation Utility

The Intel® Chipset drivers should be installed first before the software drivers to install INF files for Plug & Play function for the chipset components. Follow the instructions below to complete the installation.

1. Insert the disk enclosed in the package. Click **Intel** and then **Intel(R) Apollolake Chipset Drivers**.



2. Click **Intel(R) Chipset Software Installation Utility**.



- When the *Welcome* screen to the Intel® Chipset Device Software appears, click **Next**.



- Accept the software license agreement to continue.



- On the *Readme File Information* screen, click **Install** and then **Next**.

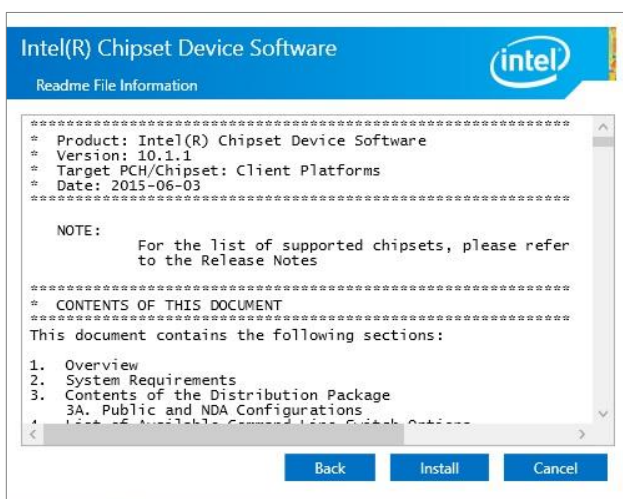

- When the driver is completely installed, click **Finish** and restart the computer for changes to take effect.

3.3 Graphics Driver Installation

1. Click **Intel** and then **Intel(R) Apollolake Chipset Drivers**.



2. Click **Intel(R) Apollolake Graphics Driver**.

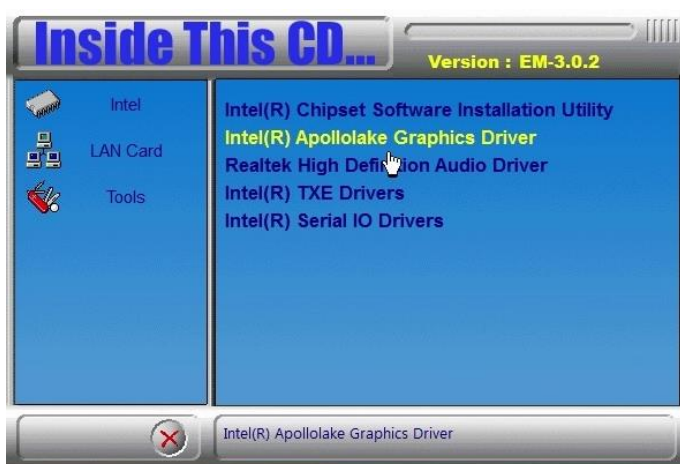

3. When the *Welcome* screen appears, click **Next** to continue.

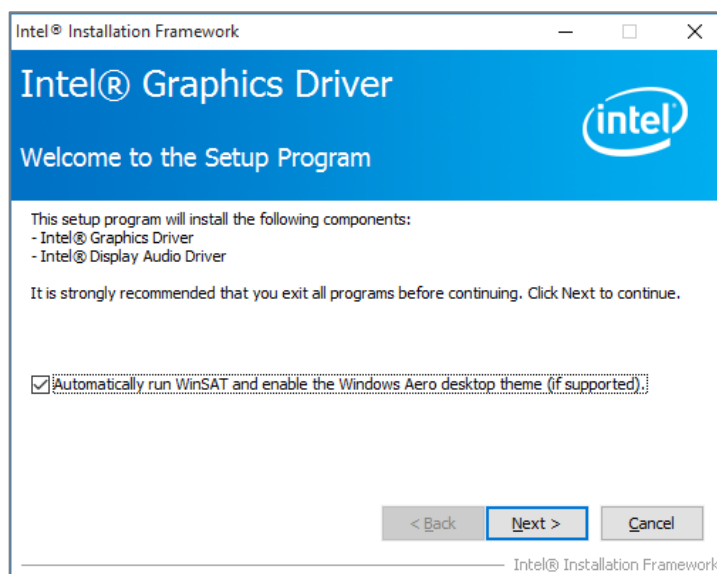

- Click **Yes** to agree with the license agreement and continue the installation.

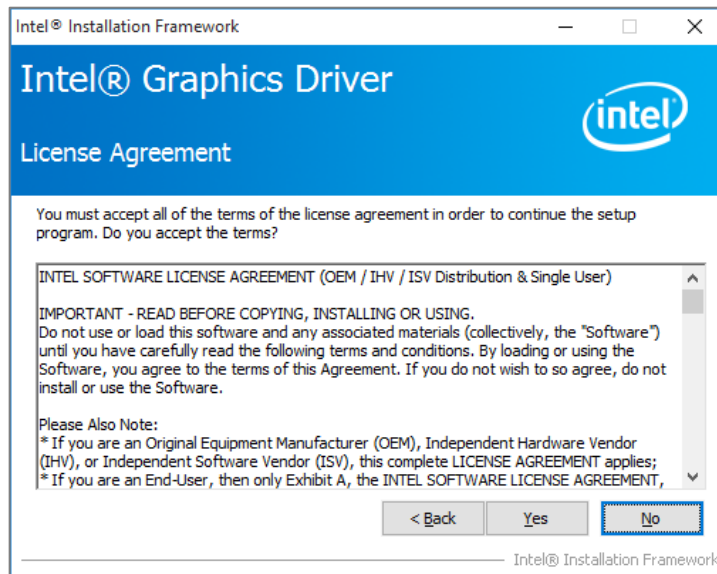

- Read the *Readme File Information* and then click **Next** until the installation starts.

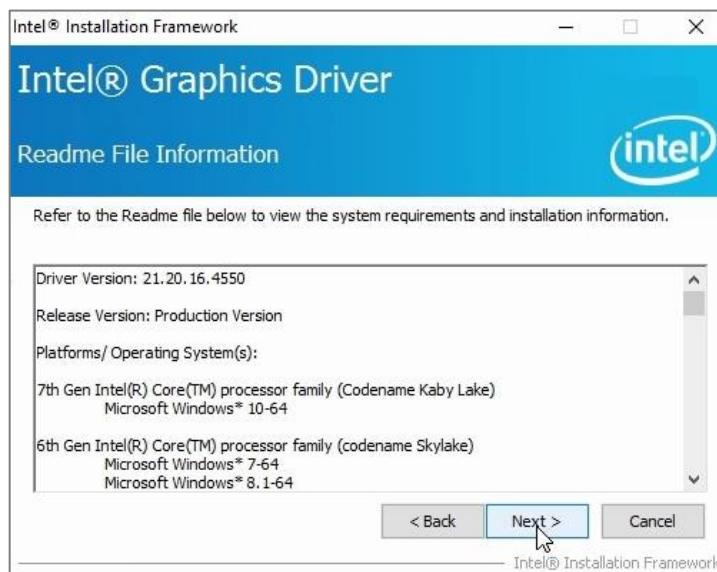

- Choose a destination folder for installation.
- When the driver is completely installed, click **Finish** and restart the computer for changes to take effect.

3.4 HD Audio Driver Installation

1. Insert the disk enclosed in the package. Click **Intel** and then **Intel(R) Apollolake Chipset Drivers**.



2. Click **Realtek High Definition Audio Driver**.



3. On the *Welcome* screen of the InstallShield Wizard, click **Next** until the installation starts.

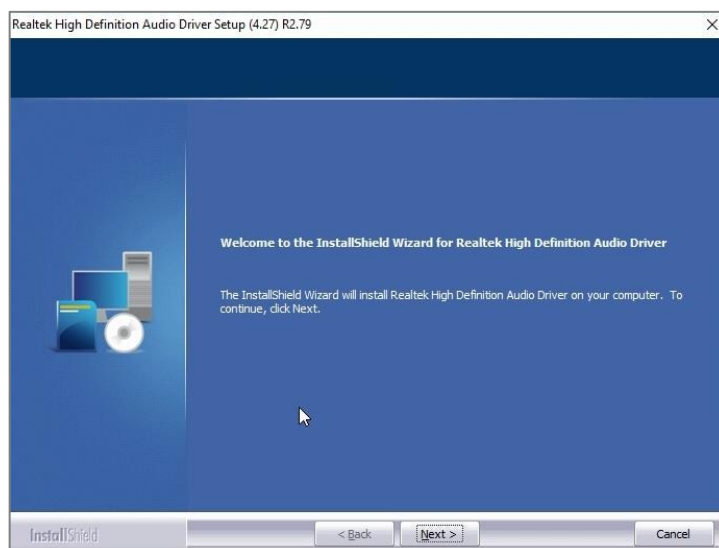

4. When the driver is completely installed, click **Finish** and restart the computer for changes to take effect.

3.5 Intel® Trusted Execution Engine Driver Installation

1. Click **Intel** and then **Intel(R) Apollolake Chipset Drivers**.



2. Click **Intel(R) TXE Drivers**.



3. When the *Welcome* screen appears, click **Next** to continue.
4. Accept the licence agreement and click **Next** to continue.
5. When the driver is completely installed, click **Finish** and restart the computer for changes to take effect.

3.6 USB 3.1 Driver Installation

1. Click **Intel** and then **Intel(R) Apollolake Chipset Drivers**.



2. Click **Intel(R) Serial IO Drivers**.



3. When the *Welcome* screen appears, click **Next** to continue.

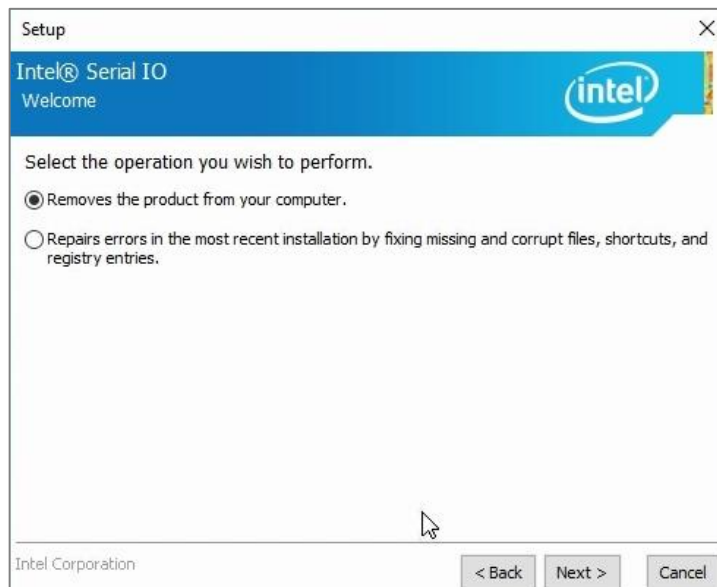

4. When the driver is completely installed, click **Finish** and restart the computer for changes to take effect.

3.7 LAN Driver Installation

1. Click **LAN Card** on the left and then **Intel(R) I21x Gigabit Network Drivers**

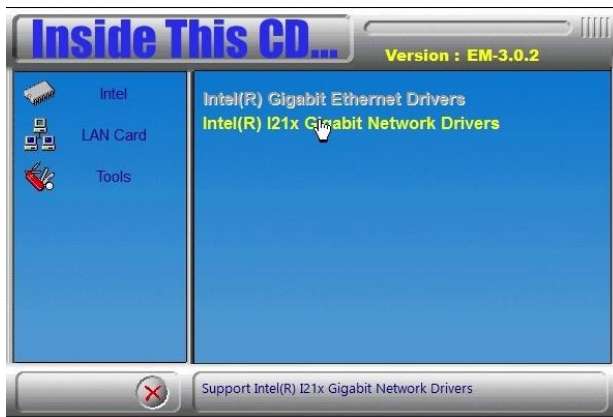

2. When the *Welcome* screen appears, click **Next** to continue.

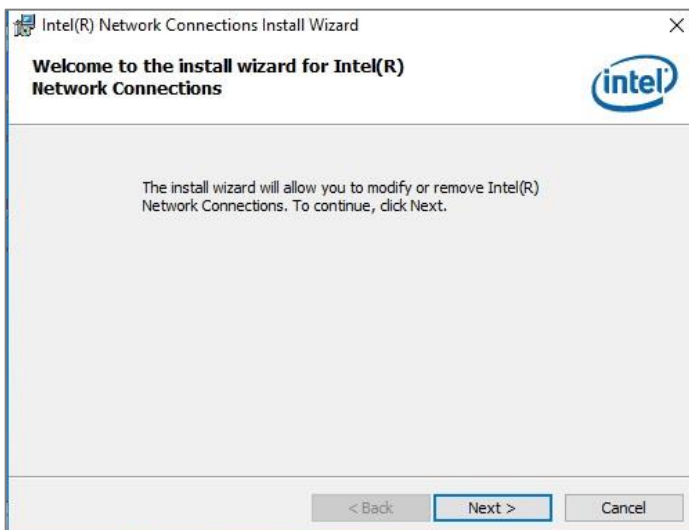

3. Tick the checkboxes to select the related drivers and click **Next**.

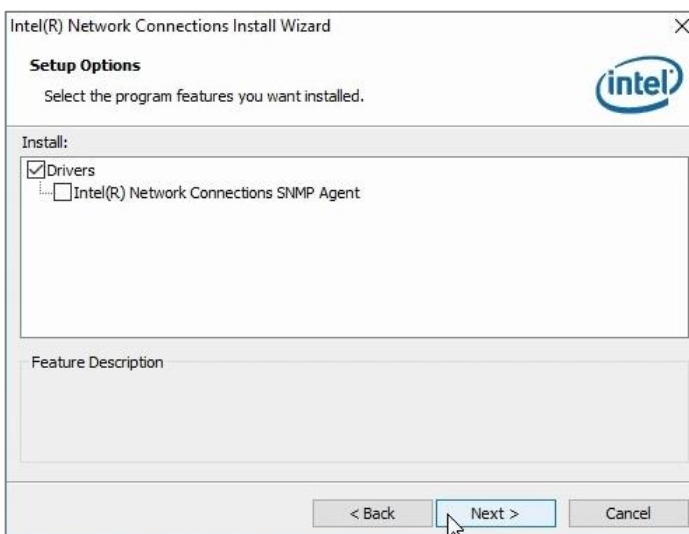

4. When the wizard is ready for installation, click **Install**.

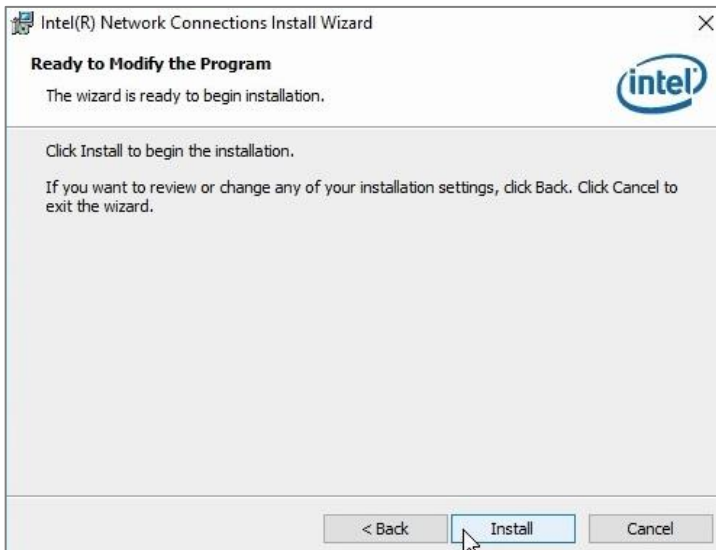

5. When the driver is completely installed, click **Finish** and restart the computer for changes to take effect.

Chapter 4

BIOS Setup

This chapter describes the different settings available in the AMI BIOS that comes with the board. The topics covered in this chapter are as follows:

- Main Settings
- Advanced Settings
- Chipset Settings
- Security Settings
- Boot Settings
- Save & Exit

4.1 Introduction

The BIOS (Basic Input/Output System) installed in the ROM of your computer system supports Intel® processors. The BIOS provides critical low-level support for standard devices such as disk drives, serial ports and parallel ports. It also provides password protection as well as special support for detailed fine-tuning of the chipset controlling the entire system.

4.2 BIOS Setup

The BIOS provides a Setup utility program for specifying the system configurations and settings. The BIOS ROM of the system stores the Setup utility. When you turn on the computer, the BIOS is immediately activated. Press the key immediately allows you to enter the Setup utility. If you are a little bit late pressing the key, POST (Power On Self Test) will continue with its test routines, thus preventing you from invoking the Setup.

If you still need to enter Setup, restart the system by pressing the "Reset" button or simultaneously pressing the <Ctrl>, <Alt> and <Delete> keys. You can also restart by turning the system Off and back On again.

The following message will appear on the screen:

```
Press <DEL> to Enter Setup
```

In general, press the arrow keys to highlight items, <Enter> to select, the <PgUp> and <PgDn> keys to change entries, <F1> for help, and <Esc> to quit.

When you enter the BIOS Setup utility, the *Main Menu* screen will appear on the screen. The Main Menu allows you to select from various setup functions and exit choices.

Warning: It is strongly recommended that you avoid making any changes to the chipset defaults.

These defaults have been carefully chosen by both AMI and your system manufacturer to provide the absolute maximum performance and reliability. Changing the defaults could make the system unstable and crash in some cases.

4.3 Main Settings

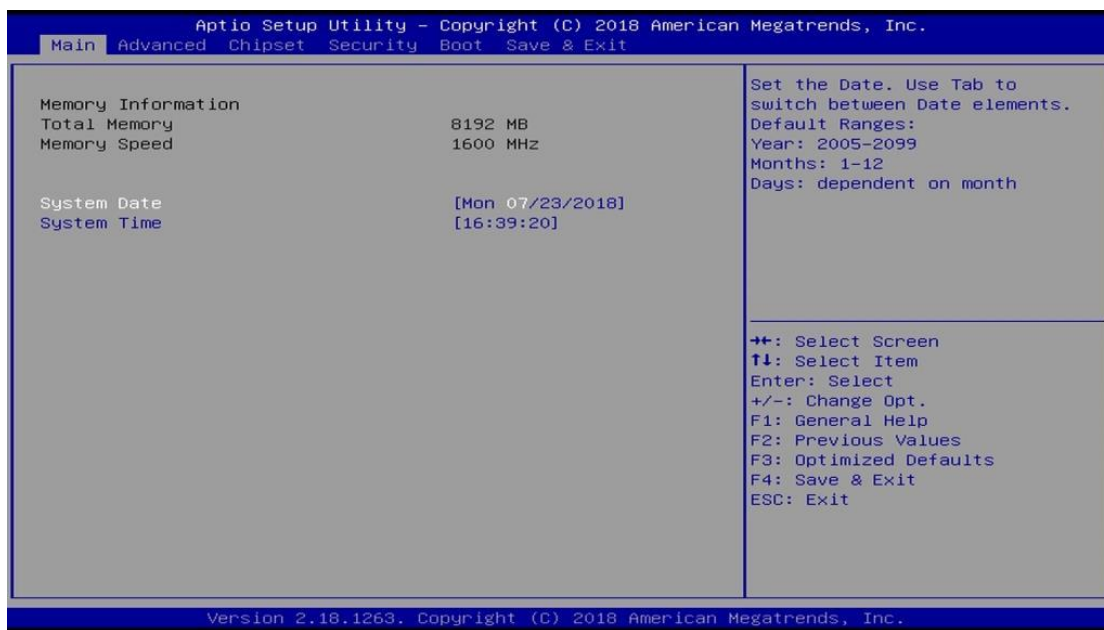

BIOS Setting	Description
System Date	Sets the date. Use the <Tab> key to switch between the data elements.
System Time	Set the time. Use the <Tab> key to switch between the data elements.

4.4 Advanced Settings

This section allows you to configure, improve your system and allows you to set up some system features according to your preference.

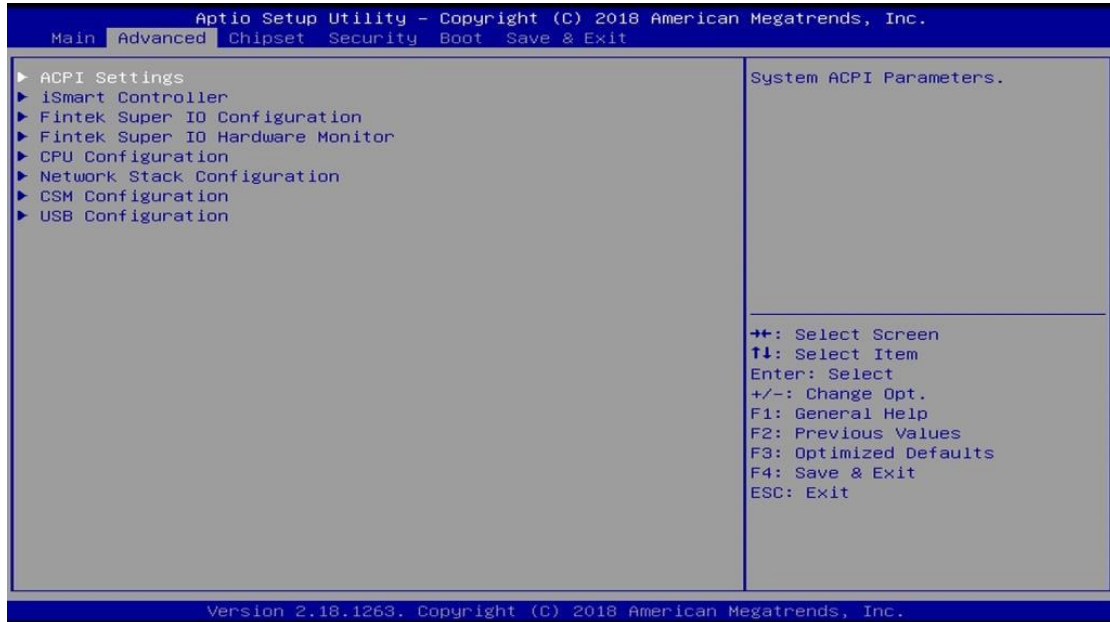

BIOS Setting	Description
ACPI Settings	Displays system ACPI parameters.
iSmart Controller	Sets up schedules for power management.
Fintek Super IO Configuration	Displays super IO chip parameters.
Fintek Super IO Hardware Monitor	Shows super IO monitor hardware status.
CPU Configuration	Displays CPU configuration parameters.
Network Stack Configuration	Enables / Disables UEFI Network Stack.
CSM Configuration	Enables / Disables option ROM execution settings, etc.
USB Configuration	Displays USB configuration parameters.

4.4.1 ACPI Settings

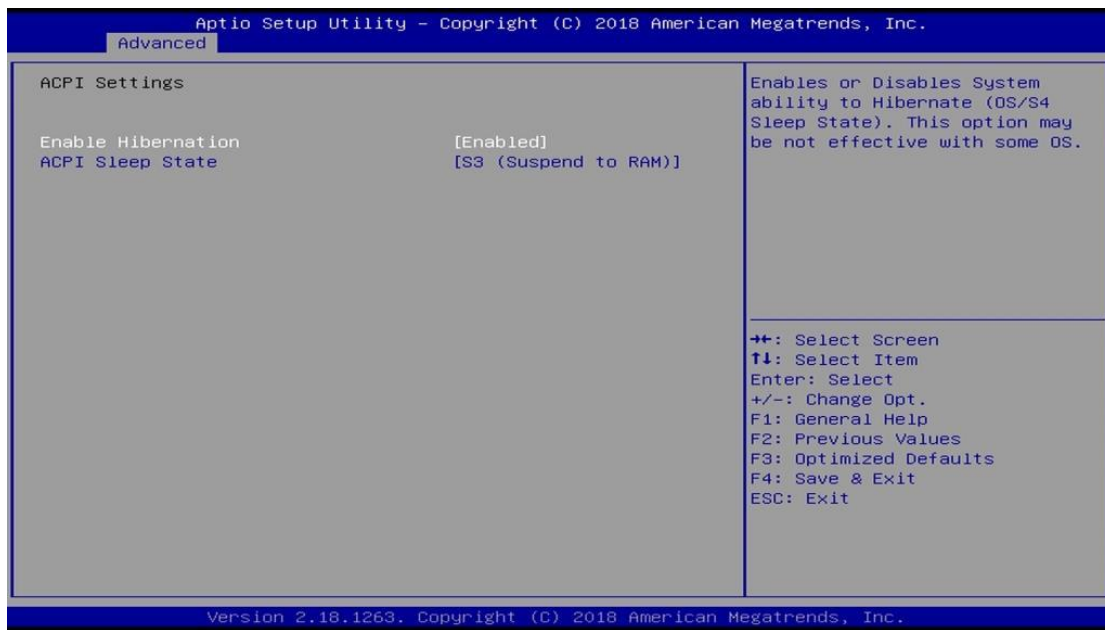

BIOS Setting	Description
Enable Hibernation	Enables / Disables the system ability to hibernate (OS/S4 Sleep State). This option may not be effective with some OS.
ACPI Sleep State	Selects a ACPI sleep state for the system to enter. Options: Suspend Disabled, S3 (Suspend to RAM)

4.4.2 iSmart Controller

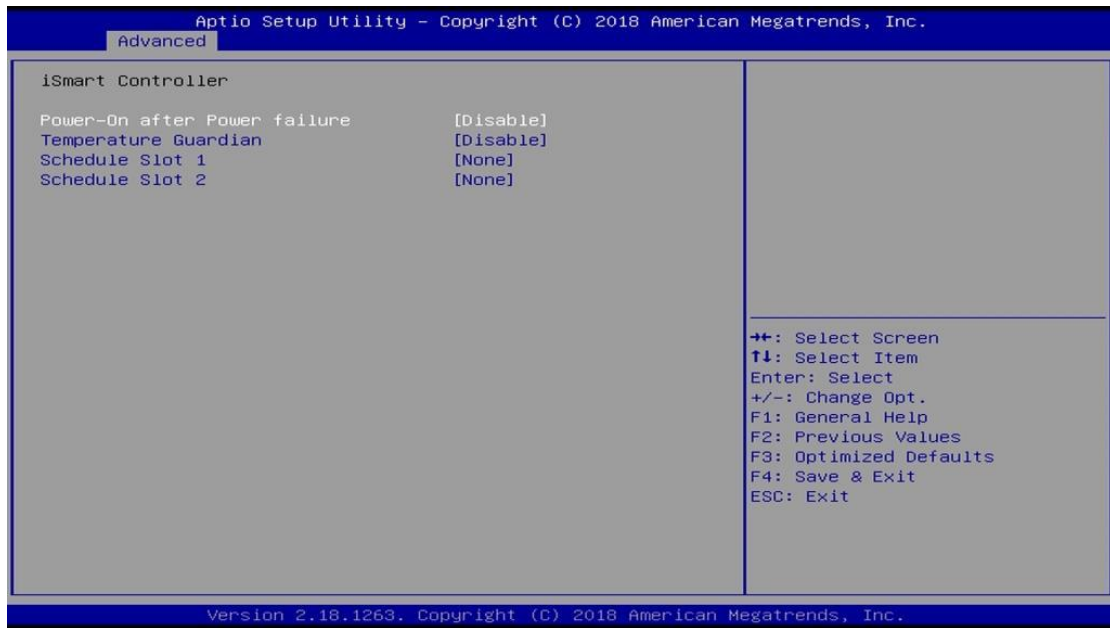

BIOS Setting	Description
Power-On after Power failure	Enables / Disables the system to be turned on automatically after a power failure.
Temperature Guardian	Generate the reset signal when system hands up on POST.
Schedule Slot 1 / 2	<p>Sets up the hour / minute / day for the power-on schedule for the system.</p> <p>Options:</p> <ul style="list-style-type: none"> • None • Power On • Power On / Off <p>Important: If you would like to set up a schedule between adjacent days, configure two schedule slots.</p> <p>For example, if setting up a schedule from Wednesday 5 p.m. to Thursday 2 a.m., configure two schedule slots. But if setting up a schedule from 3 p.m to 5 p.m. on Wednesday, configure only a schedule slot.</p>

4.4.3 Fintek Super IO Configuration

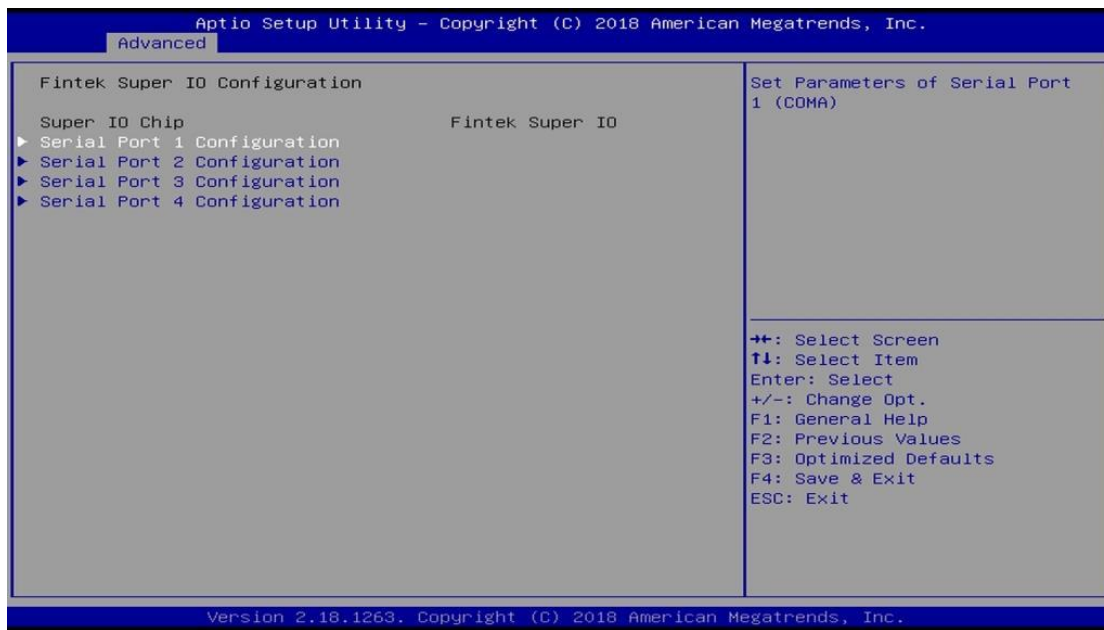

BIOS Setting	Description
Serial Port Configuration	Sets Parameters of Serial Ports. You can enable / disable the serial port and select an optimal settings for the Super IO device.

4.4.3.1. Serial Port 1 Configuration

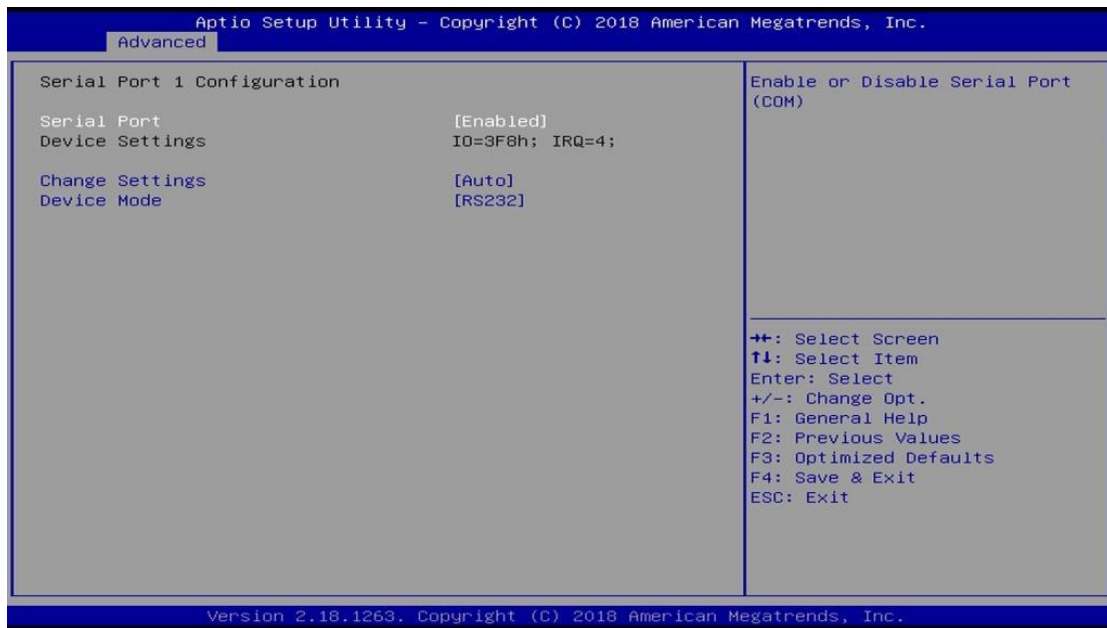

BIOS Setting	Description
Serial Port	Enables / Disables serial port (COM).
Change Settings	Selects an optimal settings for Super I/O device. Options: <ul style="list-style-type: none"> • Auto • IO = 3F8h; IRQ = 4 • IO = 3F8h; IRQ = 3, 4, 5, 6, 7, 9, 10, 11, 12 • IO = 2F8h; IRQ = 3, 4, 5, 6, 7, 9, 10, 11, 12 • IO = 3E8h; IRQ = 3, 4, 5, 6, 7, 9, 10, 11, 12 • IO = 2E8h; IRQ = 3, 4, 5, 6, 7, 9, 10, 11, 12
Device Mode	Serial port 1 loop back / RS232 / RS422 / RS485 mode select.

4.4.3.2. Serial Port 2 Configuration

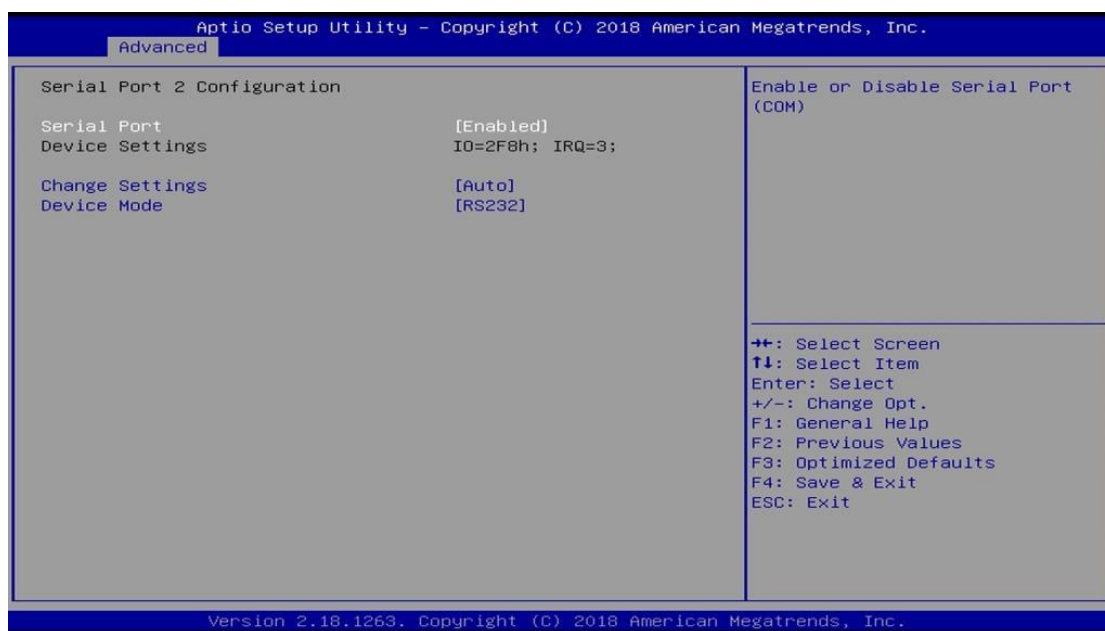

BIOS Setting	Description
Serial Port	Enables / Disables serial port (COM).
Change Settings	Selects an optimal settings for Super I/O device. Options: <ul style="list-style-type: none"> • Auto • IO = 2F8h; IRQ = 3 • IO = 3F8h; IRQ = 3, 4, 5, 6, 7, 9, 10, 11, 12 • IO = 2F8h; IRQ = 3, 4, 5, 6, 7, 9, 10, 11, 12 • IO = 3E8h; IRQ = 3, 4, 5, 6, 7, 9, 10, 11, 12 • IO = 2E8h; IRQ = 3, 4, 5, 6, 7, 9, 10, 11, 12
Device Mode	Serial port 1 loop back / RS232 / RS422 / RS485 mode select.

4.4.3.3. Serial Port 3 Configuration

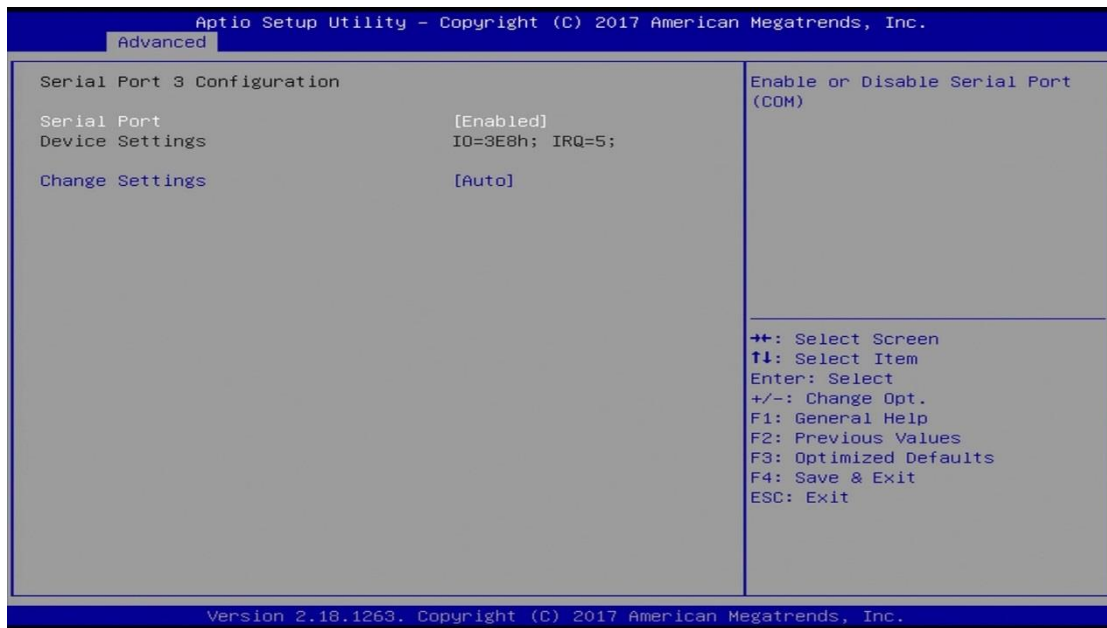

BIOS Setting	Description
Serial Port	Enables / Disables serial port (COM).
Change Settings	<p>Selects an optimal settings for Super I/O device.</p> <p>Options:</p> <ul style="list-style-type: none"> • Auto • IO = 3E8h; IRQ = 7 • IO = 3E8h; IRQ = 3, 4, 5, 6, 7, 9, 10, 11, 12 • IO = 2E8h; IRQ = 3, 4, 5, 6, 7, 9, 10, 11, 12 • IO = 2F0h; IRQ = 3, 4, 5, 6, 7, 9, 10, 11, 12 • IO = 2E0h; IRQ = 3, 4, 5, 6, 7, 9, 10, 11, 12

4.4.3.4. Serial Port 4 Configuration

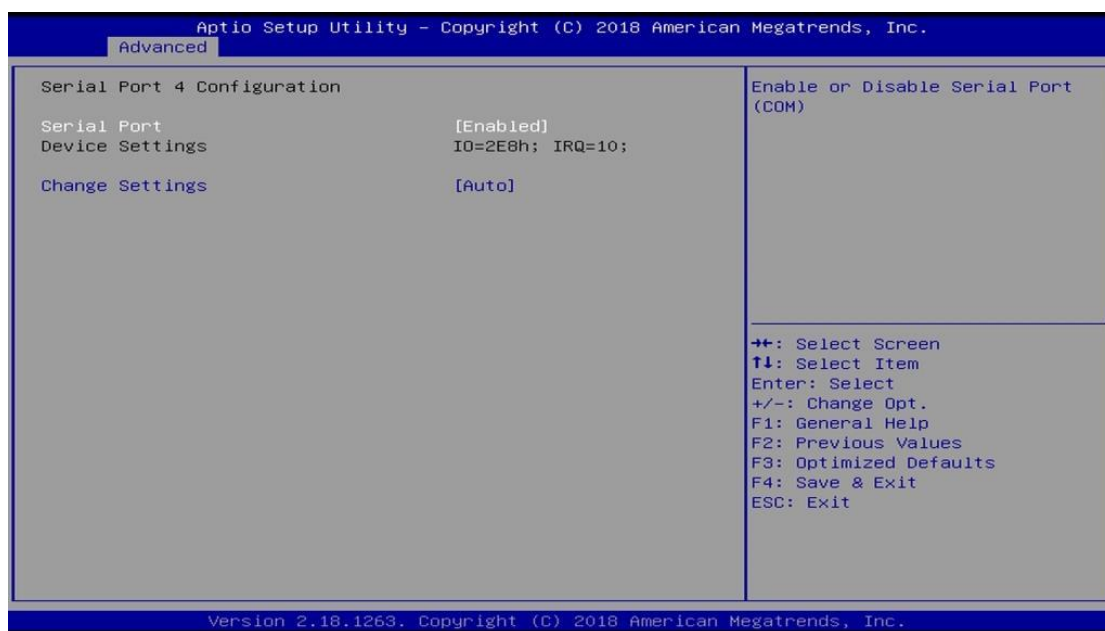

BIOS Setting	Description
Serial Port	Enables / Disables serial port (COM).
Change Settings	<p>Selects an optimal settings for Super I/O device.</p> <p>Options:</p> <ul style="list-style-type: none"> • Auto • IO = 2E8h; IRQ = 7 • IO = 3E8h; IRQ = 3, 4, 5, 6, 7, 9, 10, 11, 12 • IO = 2E8h; IRQ = 3, 4, 5, 6, 7, 9, 10, 11, 12 • IO = 2F0h; IRQ = 3, 4, 5, 6, 7, 9, 10, 11, 12 • IO = 2E0h; IRQ = 3, 4, 5, 6, 7, 9, 10, 11, 12

4.4.4 Fintek Hardware Monitor

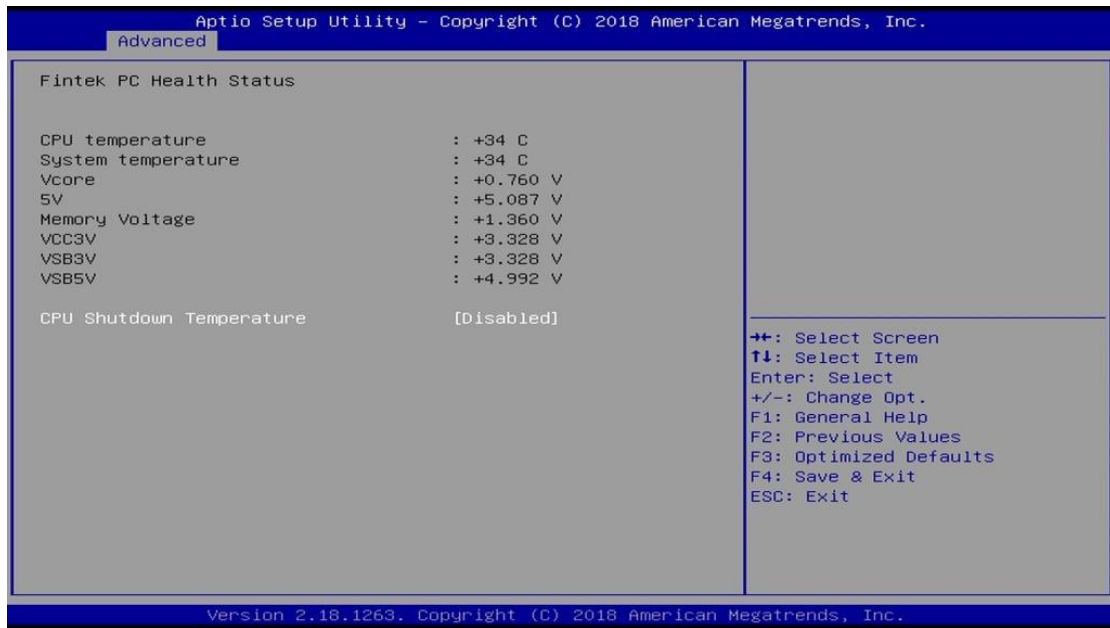

BIOS Setting	Description
Temperatures / Voltages	These fields are the parameters of the hardware monitoring function feature of the motherboard. The values are read-only as monitored by the system and showing the PC health status
CPU Shutdown Temperature	This field enables or disables the Shutdown Temperature Options: Disabled (default), 70°C, 75°C, 80°C, 85°C, 90°C, 95°C

4.4.5 CPU Configuration

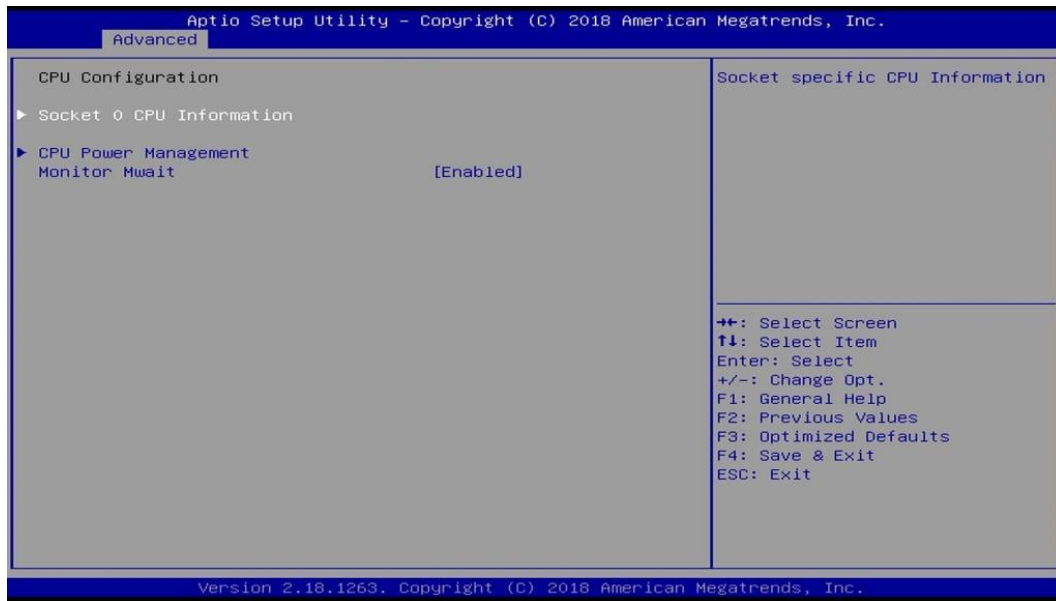

BIOS Setting	Description
Socket 0 CPU Information	Socket specific CPU Information
CPU Power Management	The turbo mode is activable for CPU power management.
Monitor Mwait	Enables / Disables Monitor Mwait.

4.4.6 Network Stack Configuration

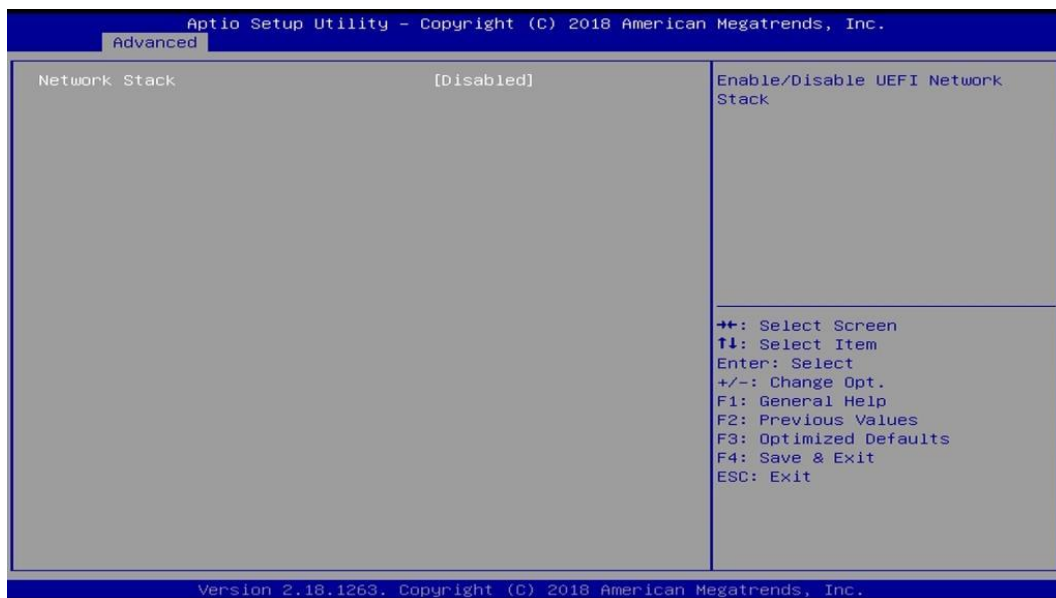

BIOS Setting	Description
Network Stack	Enables / Disables UEFI Network Stack.

4.4.7 CSM Configuration

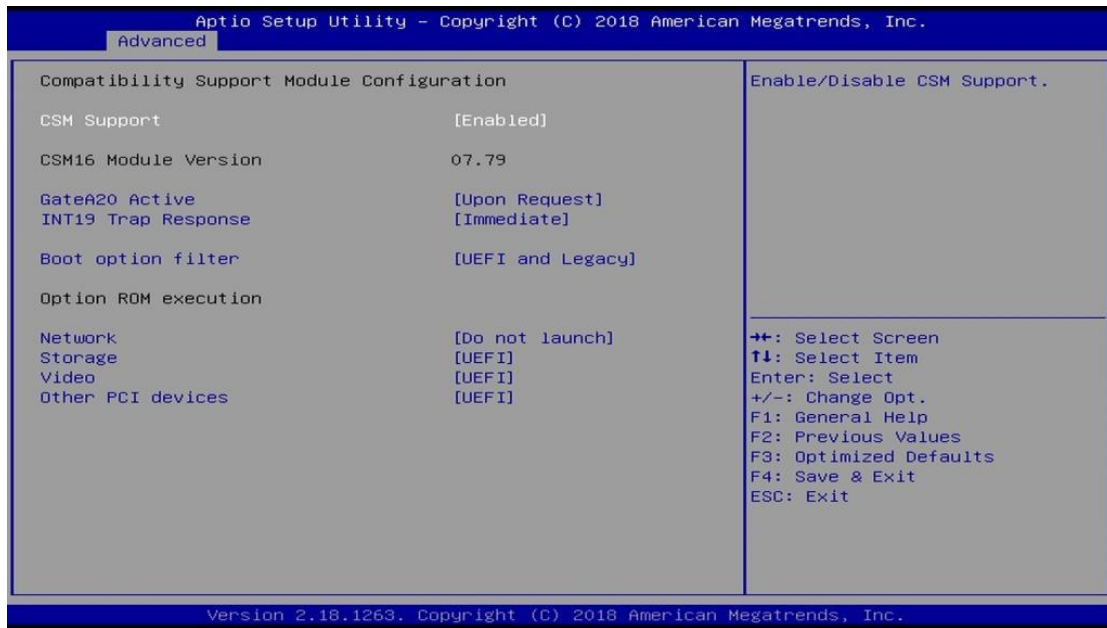

BIOS Setting	Description
CSM Support	Enables / Disables CSM support.
GateA20 Active	<ul style="list-style-type: none"> The option Upon Request disables GA20 when using BIOS services. The option Always cannot disable GA20, but is useful when any RT code is executed above 1 MB.
INT19 Trap Response	<p>Selects the way that BIOS reacts on INT19 trapping by Option ROM.</p> <ul style="list-style-type: none"> Immediate executes the trap right away Postponed executes the trap during legacy boot.
Boot option filter	Controls the priority of Legacy and UEFI.
Network	Controls the execution of UEFI and Legacy PXE OpROM.
Storage	Controls the execution of UEFI and Legacy Storage OpROM.
Video	Controls the execution of UEFI and Legacy Video OpROM.
Other PCI devices	Determines OpROM execution policy for devices other than network, storage or video.

4.4.8 USB Configuration

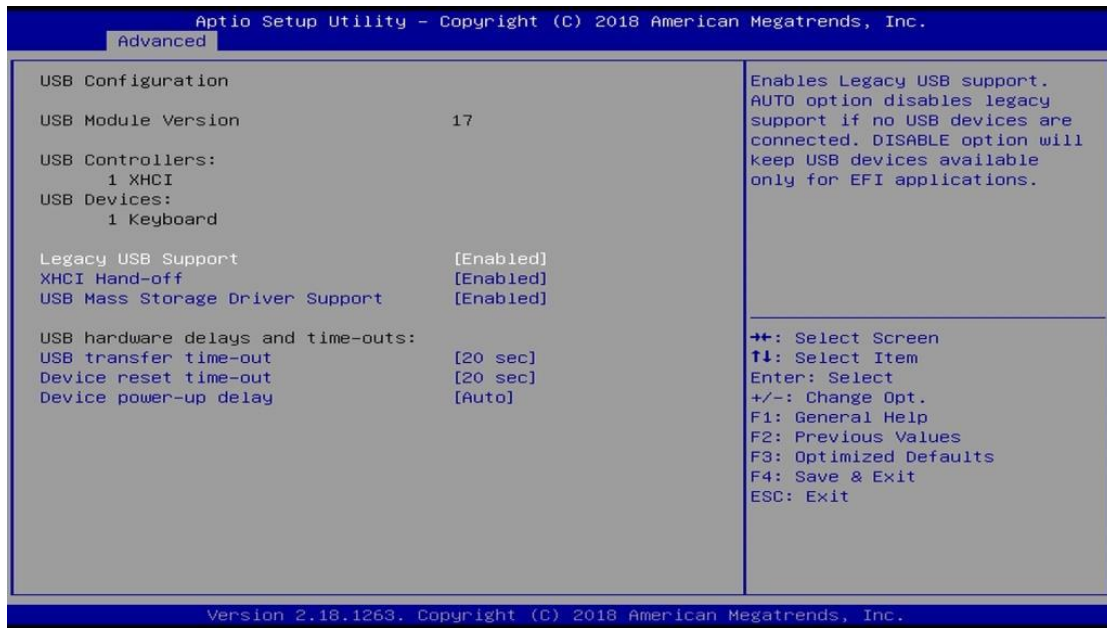

BIOS Setting	Description
Legacy USB Support	Enables / Disables Legacy USB support. <ul style="list-style-type: none"> • Auto disables legacy support if there is no USB device connected. • Disable keeps USB devices available only for EFI applications.
XHCI Hand-pff	This is a workaround for OSeS without XHCI hand-off support. The XHCI ownership change should be claimed by XHCI driver.
USB Mass Storage Driver Support	Enables / Disables USB mass storage driver support.
USB Transfer time-out	Sets the time-out value 1, 5, 10 or 20 sec(s) for Control, Bulk, and Interrupt transfers.
Device reset time-out	Sets the seconds (10, 20, 30, 40 secs) of delaying execution of start unit command to USB mass storage device.
Device power-up delay	The maximum time the device will take before it properly reports itself to the Host Controller. Auto uses default value. For a Root port, it is 100 ms. For a Hub port, the delay is taken from Hub descriptor.

4.5 Chipset Settings

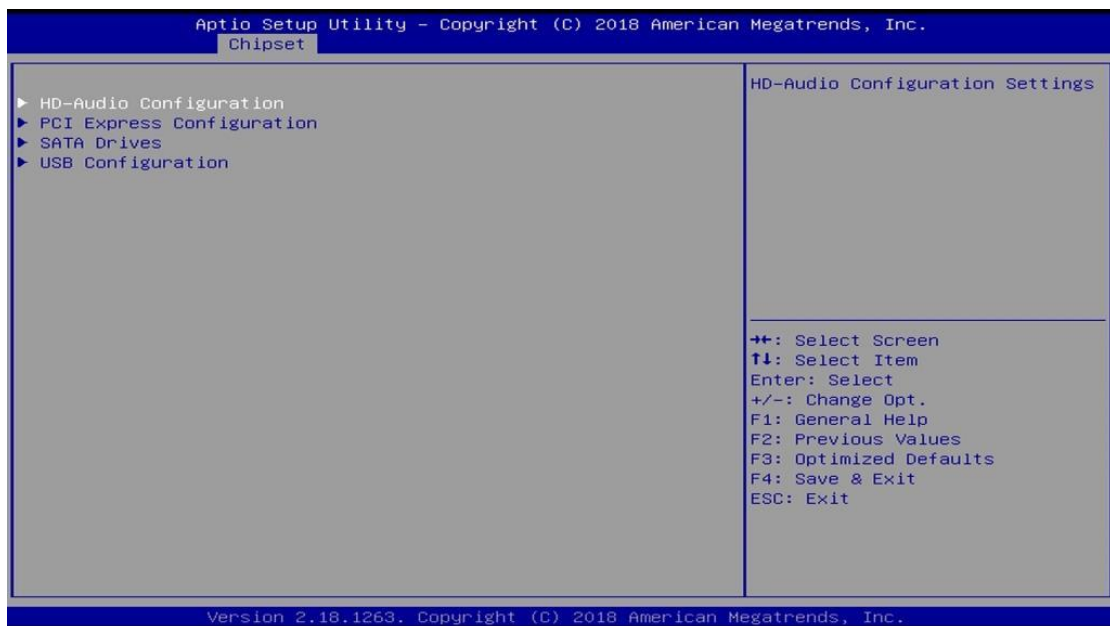
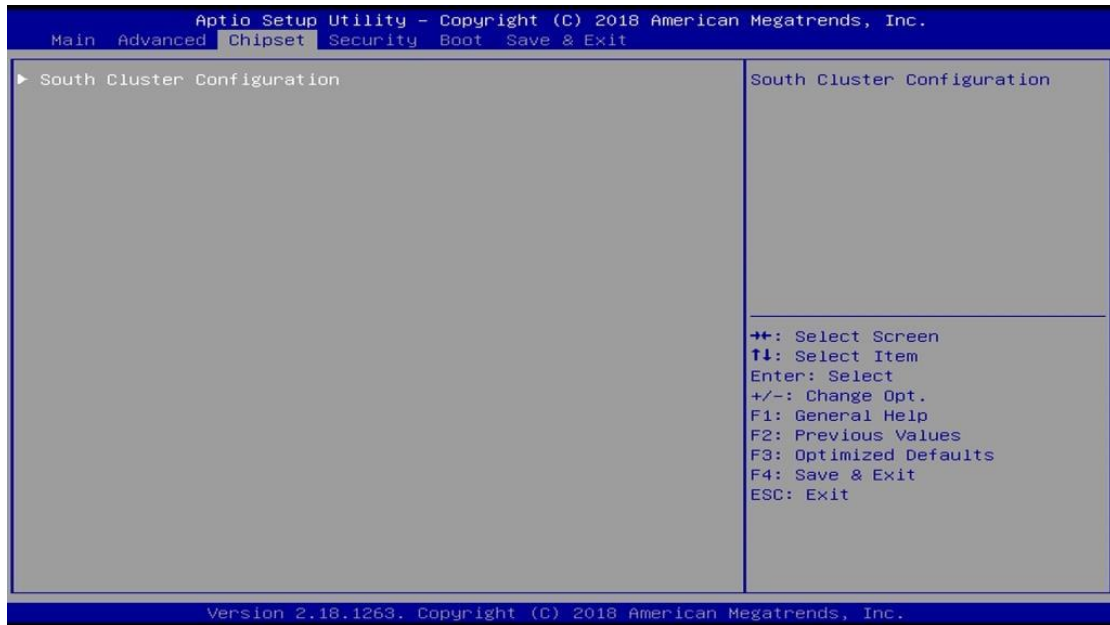

BIOS Setting	Description
HD-Audio Configuration	HD audio configuration settings
PCI Express Configuration	PCI Express Configuration Settings
SATA Drives	Press Enter to select the SATA device configuration setup options.
USB Configuration	USB configuration settings

4.5.1 HD-Audio Configuration

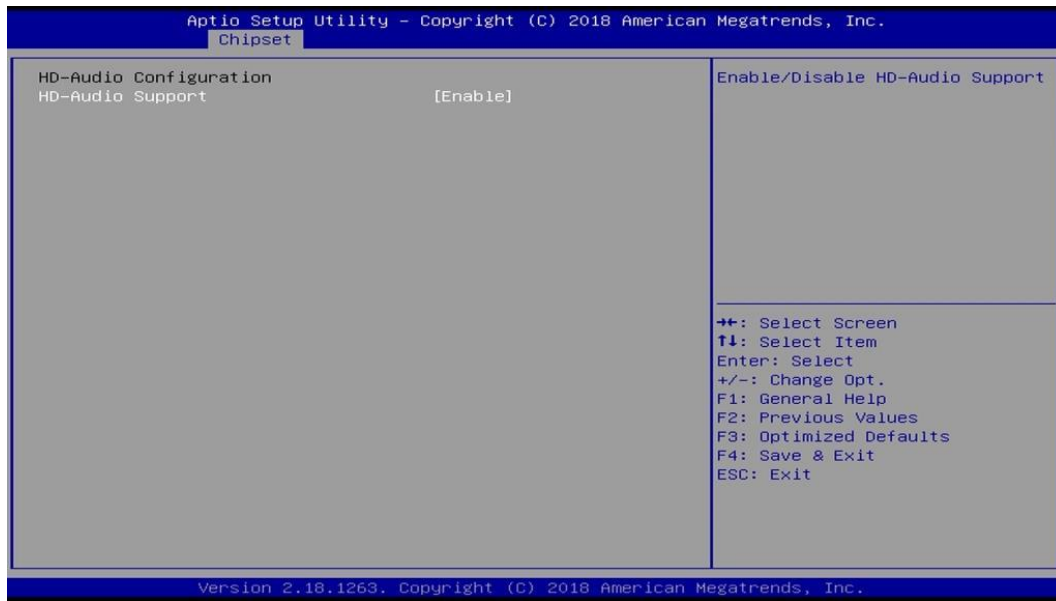

BIOS Setting	Description
HD Audio Support	Enables / Disables HD audio support.

4.5.2 PCI Express Configuration

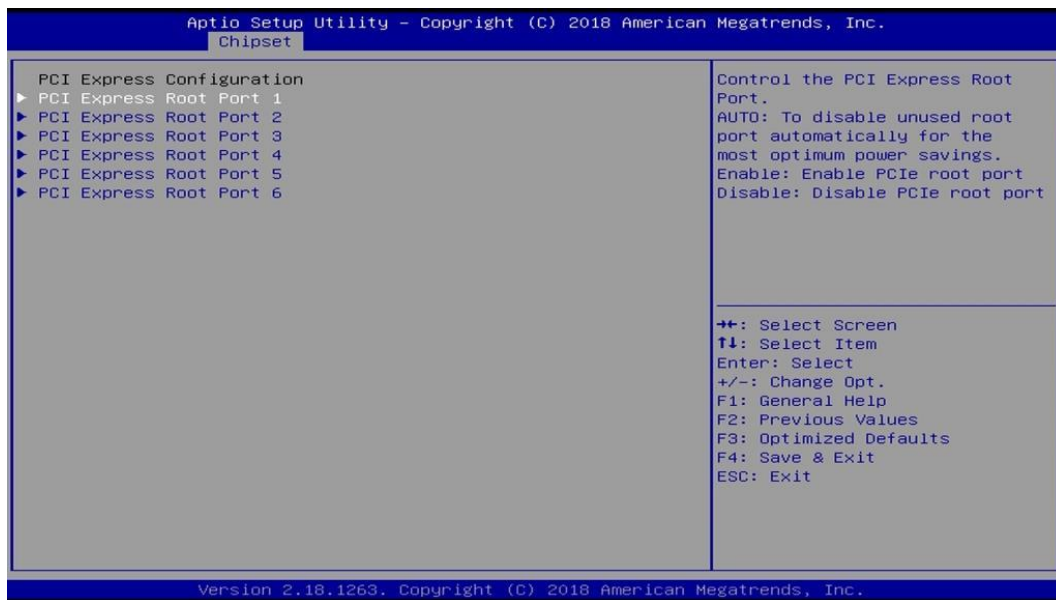

BIOS Setting	Description
PCI Express Root Port 1 ~ 6	Enables / Disables the PCI Express root port. Auto: Disables unused root port automatically for the most optimum power savings.

4.5.2.1. PCI Express Root Port 1 ~ 6

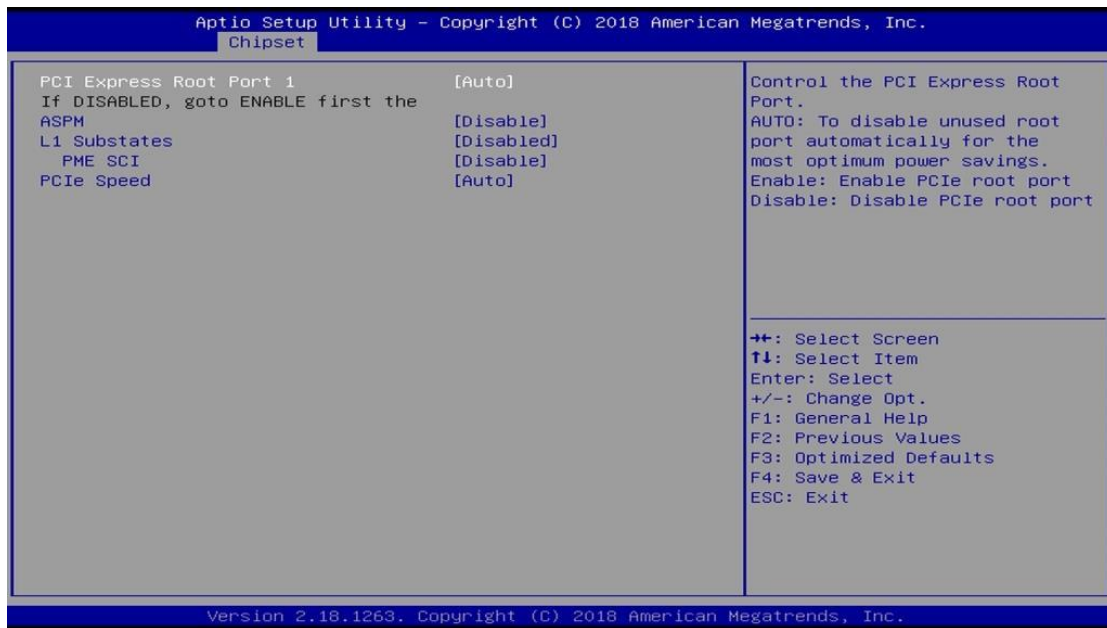

BIOS Setting	Description
PCI Express Root Port 1 ~ 6	Enables / Disables the PCI Express root port. Auto: Disables unused root port automatically for the most optimum power savings.
ASPM	PCI Express active state power management settings. Options: Disable, L0s, L1, L0sL1, Auto
L1 Substates	PCI Express L1 substates settings. Options: Disabled, L1.1, L1.2, L1.1 & L1.2
PME SCI	Enables / Disables PCI Express PME SCI.
PCIe Speed	Configures PCIe speed. Options: Auto, Gen1, Gen2

4.5.3 SATA Drives

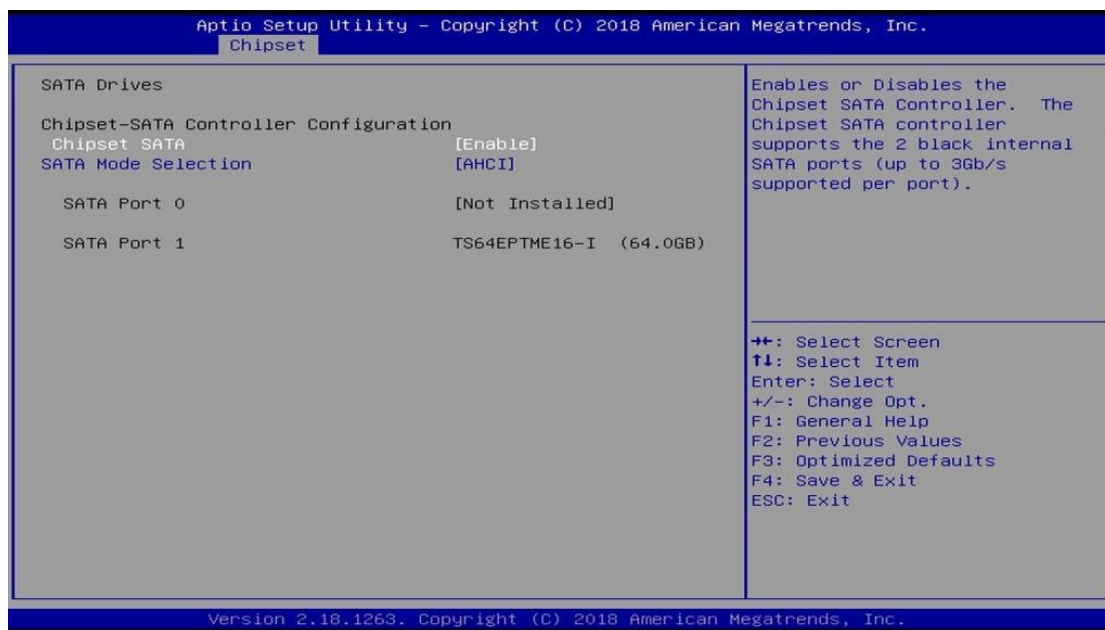

BIOS Setting	Description
Chipset SATA	Enables / Disables the Chipset SATA controller. The Chipset SATA controller supports the 2 black internal SATA ports (up to 3 Gb/s supported per port).
SATA Mode Selection	Determines how SATA controller(s) operation. Option: AHCI

4.5.4 USB Configuration

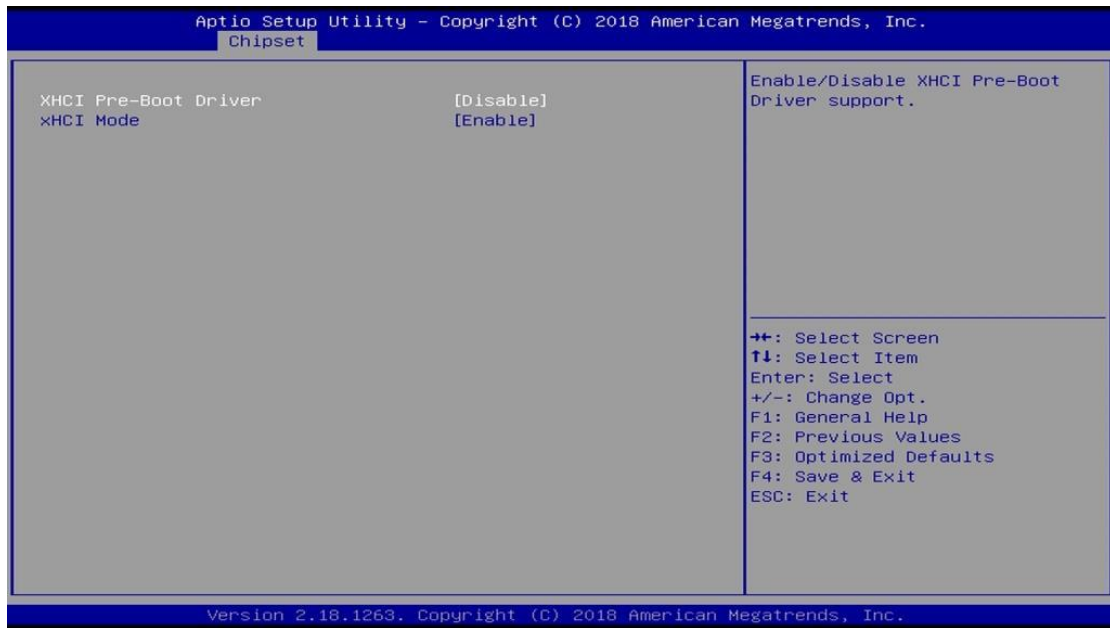

BIOS Setting	Description
XHCI Pre-Boot Driver	Enables / Disables XHCI pre-boot driver support.
XHCI Mode	Once disabled, XHCI controller would be function disabled. None of the USB devices are detectable and usable during boot and in OS. Do not disable it unless for debug purpose.

4.6 Security Settings



BIOS Setting	Description
Setup Administrator Password	Sets an administrator password for the setup utility.
User Password	Sets a user password.

4.7 Boot Settings

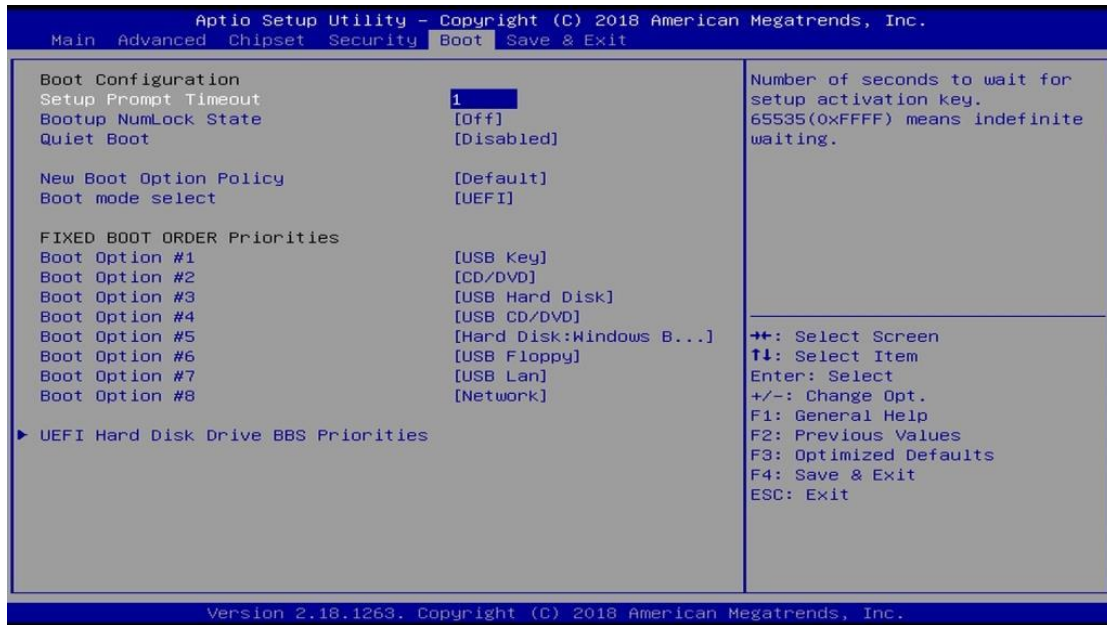

BIOS Setting	Description
Setup Prompt Timeout	Number of seconds to wait for setup activation key. 65535 (0xFFFF) means indefinite waiting.
Bootup NumLock State	Turns on/off the keyboard NumLock state.
Quiet Boot	Enables / Disables Quiet Boot option.
New Boot Option Policy	Controls the placement of newly detected UEFI boot options. Options: Default, Place First, Place Last
Boot Mode Select	Selects a Boot mode, Legacy / UEFI.
Boot Option Priorities	Sets the system boot order priorities for hard disk, CD/DVD, USB, Network.
UEFI Hard Disk Drive BBS Priorities	Specifies the boot device priority sequence from available UEFI hard disk drives.

4.8 Save & Exit Settings



BIOS Setting	Description
Save Changes and Exit	Exits system setup after saving the changes.
Discard Changes and Exit	Exits system setup without saving any changes.
Save Changes and Reset	Resets the system after saving the changes.
Discard Changes and Reset	Resets system setup without saving any changes.
Save Changes	Saves changes done so far to any of the setup options.
Discard Changes	Discards changes done so far to any of the setup options.
Restore Defaults	Restores / Loads defaults values for all the setup options.
Save as User Defaults	Saves the changes done so far as user defaults.
Restore User Defaults	Restores the user defaults to all the setup options.

Appendix

This section provides the mapping addresses of peripheral devices and the sample code of watchdog timer configuration.

- I/O Port Address Map
- Interrupt Request Lines (IRQ)
- Watchdog Timer Configuration

A. I/O Port Address Map

Each peripheral device in the system is assigned a set of I/O port addresses which also becomes the identity of the device. The following table lists the I/O port addresses used.

Address	Device Description
0x0000F090-0x0000F097	Standard SATA AHCI Controller
0x0000F080-0x0000F083	Standard SATA AHCI Controller
0x0000F060-0x0000F07F	Standard SATA AHCI Controller
0x00000A00-0x00000A0F	Motherboard resources
0x00000A10-0x00000A1F	Motherboard resources
0x00000A20-0x00000A2F	Motherboard resources
0x0000002E-0x0000002F	Motherboard resources
0x0000004E-0x0000004F	Motherboard resources
0x00000061-0x00000061	Motherboard resources
0x00000063-0x00000063	Motherboard resources
0x00000065-0x00000065	Motherboard resources
0x00000067-0x00000067	Motherboard resources
0x00000070-0x00000070	Motherboard resources
0x00000070-0x00000070	System CMOS/real time clock
0x00000080-0x0000008F	Motherboard resources
0x00000092-0x00000092	Motherboard resources
0x000000B2-0x000000B3	Motherboard resources
0x00000680-0x0000069F	Motherboard resources
0x00000400-0x0000047F	Motherboard resources
0x00000500-0x000005FE	Motherboard resources
0x00000600-0x0000061F	Motherboard resources
0x0000164E-0x0000164F	Motherboard resources
0x0000F040-0x0000F05F	Intel(R) Celeron(R)/Pentium(R) Processor SMBUS - 5AD4
0x0000D000-0x0000DFFF	Intel(R) Celeron(R)/Pentium(R) Processor PCI Express Root Port - 5AD9
0x00000020-0x00000021	Programmable interrupt controller
0x00000024-0x00000025	Programmable interrupt controller

Address	Device Description
0x00000028-0x00000029	Programmable interrupt controller
0x0000002C-0x0000002D	Programmable interrupt controller
0x00000030-0x00000031	Programmable interrupt controller
0x00000034-0x00000035	Programmable interrupt controller
0x00000038-0x00000039	Programmable interrupt controller
0x0000003C-0x0000003D	Programmable interrupt controller
0x000000A0-0x000000A1	Programmable interrupt controller
0x000000A4-0x000000A5	Programmable interrupt controller
0x000000A8-0x000000A9	Programmable interrupt controller
0x000000AC-0x000000AD	Programmable interrupt controller
0x000000B0-0x000000B1	Programmable interrupt controller
0x000000B4-0x000000B5	Programmable interrupt controller
0x000000B8-0x000000B9	Programmable interrupt controller
0x000000BC-0x000000BD	Programmable interrupt controller
0x000004D0-0x000004D1	Programmable interrupt controller
0x000003F8-0x000003FF	Communications Port (COM1)
0x000002F8-0x000002FF	Communications Port (COM2)
0x000003E8-0x000003EF	Communications Port (COM3)
0x000002E8-0x000002EF	Communications Port (COM4)
0x00000000-0x0000006F	PCI Express Root Complex
0x00000078-0x000000CF	PCI Express Root Complex
0x00000D00-0x0000FFFF	PCI Express Root Complex
0x0000E000-0x0000EFFF	Intel(R) Celeron(R)/Pentium(R) Processor PCI Express Root Port - 5AD8
0x00000040-0x00000043	System timer
0x00000050-0x00000053	System timer
0x0000F000-0x0000F03F	Intel(R) HD Graphics

B. Interrupt Request Lines (IRQ)

Peripheral devices use interrupt request lines to notify CPU for the service required. The following table shows the IRQ used by the devices on board.

Level	Function
IRQ 4294967294	Standard SATA AHCI Controller
IRQ 25	High Definition Audio Controller
IRQ 8	High precision event timer
IRQ 4	Communications Port (COM1)
IRQ 3	Communications Port (COM2)
IRQ 5	Communications Port (COM3)
IRQ 10	Communications Port (COM4)
IRQ 4294967291	Intel(R) USB 3.0 eXtensible Host Controller - 1.0 (Microsoft)
IRQ 54 ~ IRQ 204	Microsoft ACPI-Compliant System
IRQ 256 ~ IRQ 511	Microsoft ACPI-Compliant System
IRQ 14	Intel(R) Serial IO GPIO Host Controller - INT3452
IRQ 14	Intel(R) Serial IO GPIO Host Controller - INT3452
IRQ 14	Intel(R) Serial IO GPIO Host Controller - INT3452
IRQ 14	Intel(R) Serial IO GPIO Host Controller - INT3452
IRQ 0	System timer
IRQ 4294967292	Intel(R) Trusted Execution Engine Interface
IRQ 4294967293	Intel(R) HD Graphics

C. Watchdog Timer Configuration

The Watchdog Timer (WDT) is used to generate a variety of output signals after a user programmable count. The WDT is suitable for the use in the prevention of system lock-up, such as when software becomes trapped in a deadlock. Under these sorts of circumstances, the timer will count to zero and the selected outputs will be driven.

Under normal circumstance, you will need to restart the WDT at regular intervals before the timer counts to zero.

Sample Code

```
//-----  
//  
// THIS CODE AND INFORMATION IS PROVIDED "AS IS" WITHOUT WARRANTY OF ANY  
// KIND, EITHER EXPRESSED OR IMPLIED, INCLUDING BUT NOT LIMITED TO THE  
// IMPLIED WARRANTIES OF MERCHANTABILITY AND/OR FITNESS FOR A PARTICULAR  
// PURPOSE.  
//  
//-----  
#include <dos.h>  
#include <conio.h>  
#include <stdio.h>  
#include <stdlib.h>  
#include "F81964.H"  
//-----  
int main (int argc, char *argv[]); void EnableWDT(int);  
void DisableWDT(void);  
//-----  
int main (int argc, char *argv[])  
{  
    unsigned char bBuf;  
    unsigned char bTime;  
    char **endptr;  
  
    char SIO;  
    printf("Fintek 81866 watch dog program\n");  
    SIO = Init_F81964();  
    if (SIO == 0)  
    {  
        printf("Can not detect Fintek 81866, program abort.\n");  
        return(1);  
    }/if (SIO == 0)  
  
    if (argc != 2)  
    {  
        printf(" Parameter incorrect!!\n");  
        return (1);  
    }  
  
    bTime = strtol (argv[1], endptr, 10);
```

```

printf("System will reset after %d seconds\n", bTime);

if (bTime)
{   EnableWDT(bTime); }
else
{   DisableWDT(); }
return 0;
}
//-----
void EnableWDT(int interval)
{
    unsigned char bBuf;

    bBuf = Get_F81964_Reg(0x2B);
    bBuf &= (~0x20);
    Set_F81964_Reg(0x2B, bBuf);           //Enable WDTO

    Set_F81964_LD(0x07);                 //switch to logic device 7
    Set_F81964_Reg(0x30, 0x01);         //enable timer

    bBuf = Get_F81964_Reg(0xF5);
    bBuf &= (~0x0F);
    bBuf |= 0x52;
    Set_F81964_Reg(0xF5, bBuf);         //count mode is second
    Set_F81964_Reg(0xF6, interval);     //set timer
    bBuf = Get_F81964_Reg(0xFA);
    bBuf |= 0x01;
    Set_F81964_Reg(0xFA, bBuf);         //enable WDTO output

    bBuf = Get_F81964_Reg(0xF5);
    bBuf |= 0x20;
    Set_F81964_Reg(0xF5, bBuf);         //start counting
}
//-----
void DisableWDT(void)
{
    unsigned char bBuf;
    Set_F81964_LD(0x07);                 //switch to logic device 7
    bBuf = Get_F81964_Reg(0xFA);
    bBuf &= ~0x01;
    Set_F81964_Reg(0xFA, bBuf);         //disable WDTO output

    bBuf = Get_F81964_Reg(0xF5);
    bBuf &= ~0x20;
    bBuf |= 0x40;
    Set_F81964_Reg(0xF5, bBuf);         //disable WDT
}
//-----

```

iBASE

```
//-----  
//  
// THIS CODE AND INFORMATION IS PROVIDED "AS IS" WITHOUT WARRANTY OF ANY  
// KIND, EITHER EXPRESSED OR IMPLIED, INCLUDING BUT NOT LIMITED TO THE  
// IMPLIED WARRANTIES OF MERCHANTABILITY AND/OR FITNESS FOR A PARTICULAR  
// PURPOSE.  
//  
//-----  
#include "F81964.H"  
#include <dos.h>  
//-----  
unsigned int F81964_BASE; void Unlock_F81964 (void); void Lock_F81964 (void);  
//-----  
unsigned int Init_F81964(void)  
{  
    unsigned int result;  
    unsigned char ucDid;  
  
    F81964_BASE = 0x4E;  
    result = F81964_BASE;  
  
    ucDid = Get_F81964_Reg(0x20);  
    if (ucDid == 0x07) //Fintek 81866  
    {    goto Init_Finish; }  
  
    F81964_BASE = 0x2E;  
    result = F81964_BASE;  
  
    ucDid = Get_F81964_Reg(0x20);  
    if (ucDid == 0x07) //Fintek 81866  
    {    goto Init_Finish; }  
  
    F81964_BASE = 0x00;  
    result = F81964_BASE;  
  
Init_Finish:  
    return (result);  
}  
//-----  
void Unlock_F81964 (void)  
{  
    outportb(F81964_INDEX_PORT, F81964_UNLOCK);  
    outportb(F81964_INDEX_PORT, F81964_UNLOCK);  
}  
//-----  
void Lock_F81964 (void)  
{  
    outportb(F81964_INDEX_PORT, F81964_LOCK);  
}  
//-----  
void Set_F81964_LD( unsigned char LD)  
{  
    Unlock_F81964();  
    outportb(F81964_INDEX_PORT, F81964_REG_LD);  
}
```

```

        outportb(F81964_DATA_PORT, LD); Lock_F81964();
    }
//-----
void Set_F81964_Reg( unsigned char REG, unsigned char DATA)
{
    Unlock_F81964();
    outportb(F81964_INDEX_PORT, REG);
    outportb(F81964_DATA_PORT, DATA);
    Lock_F81964();
}
//-----
unsigned char Get_F81964_Reg(unsigned char REG)
{
    unsigned char Result;
    Unlock_F81964();
    outportb(F81964_INDEX_PORT, REG);
    Result = inportb(F81964_DATA_PORT);
    Lock_F81964();
    return Result;
}
//-----

//-----
//
// THIS CODE AND INFORMATION IS PROVIDED "AS IS" WITHOUT WARRANTY OF ANY
// KIND, EITHER EXPRESSED OR IMPLIED, INCLUDING BUT NOT LIMITED TO THE
// IMPLIED WARRANTIES OF MERCHANTABILITY AND/OR FITNESS FOR A PARTICULAR
// PURPOSE.
//
//-----
#ifndef    F81964_H
#define    F81964_H    1
//-----
#define    F81964_INDEX_PORT    (F81964_BASE)
#define    F81964_DATA_PORT    (F81964_BASE+1)
//-----
#define    F81964_REG_LD    0x07
//-----
#define    F81964_UNLOCK    0x87
#define    F81964_LOCK    0xAA
//-----
unsigned int Init_F81964(void);
void Set_F81964_LD( unsigned char);
void Set_F81964_Reg( unsigned char, unsigned char); unsigned char
Get_F81964_Reg( unsigned char);
//-----
#endif //    F81964_H

```