

OFT-21WR1

21.5" Open Frame Tablet

Quick Reference Guide

1st Ed – 08 February 2022

Copyright Notice

Copyright © 2022 Avalue Technology Inc., ALL RIGHTS RESERVED.



Federal Communication Commission Interference Statement

THIS DEVICE COMPLIES WITH PART 15 OF THE FCC RULES. OPERATION IS SUBJECT TO THE FOLLOWING TWO CONDITIONS: (1) THIS DEVICE MAY NOT CAUSE HARMFUL INTERFERENCE AND (2) THIS DEVICE MUST ACCEPT ANY INTERFERENCE RECEIVED, INCLUDING INTERFERENCE THAT MAY CAUSE UNDESIRE OPERATION.

Note: This equipment has been tested and found to comply with the limits for a Class A digital device, pursuant to Part 15 of FCC Rules. These limits are designed to provide reasonable protection against harmful interference in a residential installation. This equipment generates, uses and can radiate radio frequency energy and, if not installed and used in accordance with the instruction, may cause harmful interference to radio communications. However, there is no guarantee that interference will not occur in a particular installation. If this equipment does cause harmful interference to radio or television reception, which can be determined by turning the equipment off and on, the user is encouraged to try to correct the interference by one or more of the following measures:

- **Reorient or relocate the receiving antenna.**
- **Increase the separation between the equipment and receiver.**
- **Connect the equipment into an outlet on a circuit different from that to which the receiver is connected.**
- **Consult the dealer or an experienced radio/TV technician for help.**

Notice:

- (1) A Unshielded-type power cord is required in order to meet FCC emission limits and also to prevent interference to the nearby radio and television reception. It is essential that only the supplied power cord be used.**
- (2) Use only shielded cables to connect I/O devices to this equipment.**
- (3) Changes or modifications not expressly approved by the party responsible for compliance could void the user's authority to operate the equipment.**

FCC RF Radiation Exposure Statement

This Wireless LAN radio device has been evaluated under FCC Bulletin OET 65 and found compliant to the requirements as set forth in CFR 47 Sections 2.1091, 2.1093, and 15.247 (b) (4) addressing RF Exposure from radio frequency devices. The radiated output power of this Wireless LAN device is far below the FCC radio frequency exposure limits. Nevertheless, this device shall be used in such a manner that the potential for human contact during normal operation is minimized. When nearby persons has to be kept to ensure RF exposure compliance, in order to comply with RF exposure limits established in the ANSI C95.1 standards, the distance between the antennas and the user should not be less than 20 cm.

WARNING

“CAUTION – Use suitable mounting apparatus to avoid risk of injury.”

“CAUTION – This is a Class A product. In a domestic environment this product may cause radio interference in which case the user may be required to take adequate measures”

“CAUTION –Risk of explosion if battery is replaced by an incorrect type. Dispose of used batteries according to the instructions.”

“CAUTION - Use a power cord that matches the voltage of the power outlet, which has been approved and complies with the safety standard of your particular country.”

“WARNING – To avoid risk of electric shock, this equipment must only be connected to a supply mains with protective earth.”

Content

1. Getting Started	6
1.1 Safety Precautions	6
1.2 Packing List	6
1.3 System Specifications	7
1.4 System Overview.....	10
1.4.1 Top View	10
1.4.2 Bottom View	10
1.5 System Dimensions.....	11
1.5.1 Front and Rear side	11
1.5.2 Installing Extend Brackets.....	12
1.6 Flush Mounting Concept	13
1.7 Panel Mounting	14
1.8 Wall Mounting Concept.....	24
1.9 Wall Mounting	25
2. Hardware Configuration	34
2.2 ACP-RK3288B Overviews	35
2.3 ACP-RK3288B Connector list	36
2.4 Ethernet LED behavior.....	37
2.5 Evaluation Cable Kit (Optional).....	37
2.6 ACP-RK3288B Jumpers & Connectors settings	38
2.6.1 AT/ATX Input power select (JSATX1).....	38
2.6.2 Touch button board connector (JTB1).....	38
2.6.3 General purpose I/O connector (JGPIO1).....	39
2.6.4 RS-485 connector (J485_COM2).....	40
2.6.5 USB Camera connector (JCAM_DMIC1).....	40
2.6.6 A-MIC connector (JAMIC1)	41
2.6.7 DC Power-in connector (DCIN2)	41
2.6.8 Speaker connector (JSPK1).....	42
2.6.9 I2C connector (JSEN1).....	42
2.6.10 USB Touch connector (JUTP1).....	43
2.6.11 Debug connector (JDBG1)	43
2.6.12 Serial port 1 connector (JCOM1).....	44
2.6.13 RTC Battery connector (JBAT1).....	44
2.6.14 MCU Firmware upgrade connector (JMCU1).....	45
2.6.15 Power Button (PWRBTN1).....	45
2.6.16 LVDS connector (LVDS1).....	46

1. Getting Started

1.1 Safety Precautions

Warning!



Always completely disconnect the power cord from your chassis whenever you work with the hardware. Do not make connections while the power is on. Sensitive electronic components can be damaged by sudden power surges. Only experienced electronics personnel should open the PC chassis.

Caution!



Always ground yourself to remove any static charge before touching the CPU card. Modern electronic devices are very sensitive to static electric charges. As a safety precaution, use a grounding wrist strap at all times. Place all electronic components in a static-dissipative surface or static-shielded bag when they are not in the chassis.

1.2 Packing List

- 1 x OFT-21WR1 Open Frame Tablet
- Power cord / Power adapter (Optional)
- Screw M3-4mm x1pc, ziplock bag No.00 40x60mm x1pc



If any of the above items is damaged or missing, contact your retailer.

1.3 System Specifications

Board Specification	
Mother Board	ACP-RK3288B
CPU	RockChip RK3288
Memory	2GB DDR3L
Storage	16GB eMMC
Power Supply	DC in
Adapter	60W, 12V power adaptor
Speaker	1 x Speaker interface
Microphone	1 x A-MIC interface
Camera	2 x 5p USB Camera (including DMIC)
Sensor	1 x interface for sensor (light sensor) G sensor On board
Operating System	Android 8.1
Wifi/BT	1 x AzureWave AW-NB177NF Wireless 802.11b/g/n WLAN+BT Combo Module
Storage	
Other Storage Device	16G eMMC
Panel & Touch	
LCD Panel	21.5" Innolux M215HJJ-L30 1920 x 1080
Touch Screen	21.5" Sense
Touch Controller	EETI 84H5680
Internal I/O Connectors	
USB OTG	Micro USB x 1
USB Camera	JCAM1 5P x 2, pitch 2.0mm
USB Touch	JUTP1 5P x 1, pitch 2.0mm
Micro SD	Micro SD x 1
M.2 Socket	M.2 B-Key x 1 (3042) x1
Touch Button	JTB1 6P x 2, pitch 2.0mm
DC in 2	4P x 1 (12 ~ 24V), pitch 2.0mm
eDP	21.5" 1920 x 1080
Analog MIC	JAMIC1 3P x 1, pitch 2.0mm
Speaker	JSPK1 4P x 1, pitch 2.0mm
Sensor	JSEN1 I2C x 2, 5P x 2, pitch 2.0mm
G Sensor	Yes

OFT-21WR1

Console Debug	JDBG1 3P x 1, pitch 2.0mm
RS232	JCOM1 5P x 1, pitch 2.0mm
RS485	JCOM2 5P x 2, pitch 2.0mm
GPIO	JGPIO1 10P x 2, 16bit, pitch 1.0mm
RTC Battery	JBAT1 2P, pitch 1.25mm
External I/O	
DC in Power jack	1 x Power Jack
USB Port	2 x USB Type A Host
Video Port	1 x HDMI
Audio Port	1 x Headphone Jack for Line out
Expansion Slots	1 x Micro SD slot
Reset	1 x Reset
Mechanical	
Power Type	12V ~ 24V wide voltage DC input
Power Connector Type	DC jack
Dimension	501.88 x 296.2 x 44.1 mm
Weight	3.4kg
Color	Metallic
Fanless	Yes
OS Support	Android 8.1
Reliability	
EMI Test	CE FCC class A
Safety	IEC62368-1 & EN62368-1
Random Vibration Operation	<ol style="list-style-type: none"> 1. PSD: 0.00454G²/Hz, 1.5 Grms 2. Operation mode 3. Test Frequency : 5-500Hz 4. Test Axis : X,Y and Z axis 5. 30 minutes per each axis 6. IEC 60068-2-64 Test:Fh 7. Storage : CF or SSD
Sine Vibration test (Non-operation)	<ol style="list-style-type: none"> 1 Test Acceleration : 2G 2 System condition: Non-Operating mode 3 Test frequency : 5~500 Hz 4 Sweep : 1 Oct/ per one minute. (logarithmic) 5 Test Axis : X,Y and Z axis 6 Test time : 10 min. each axis <p>Reference IEC 60068-2-6 Testing procedures</p>

Package vibration test	<ol style="list-style-type: none"> 1. PSD: 0.026G²/Hz , 2.16 Grms 2. Non-operation mode 3. Test Frequency : 5-500Hz 4. Test Axis : X,Y and Z axis 5. 30 min. per each axis 6. IEC 60068-2-64 Test:Fh
Bump Test	<ol style="list-style-type: none"> 1. Wave form : Half Sine wave 2. Acceleration Rate : 10g for operation mode 3. Duration Time : 11ms 4. No. of Shock : Z axis 300 times 5. Test Axis: Z axis 6. Operation mode 7. Reference IEC 60068-2-29 Testing procedures Test Eb : Bump Test
Package Drop test	<ol style="list-style-type: none"> 1 One corner , three edges, six faces 2 ISTA 2A, IEC-60068-2-32 Test:Ed
Operating Temperature	0°C ~ 40°C
Operating Humidity	40°C @ 95% Relative Humidity, Non-condensing
Storage Temperature	-20°C ~ 60°C



Note: Specifications are subject to change without notice.

1.4 System Overview

1.4.1 Top View

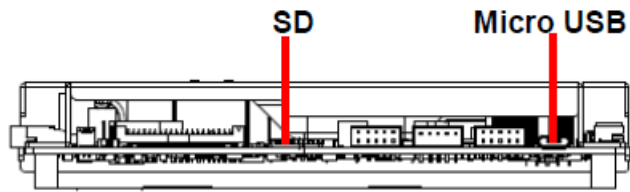

1.4.2 Bottom View

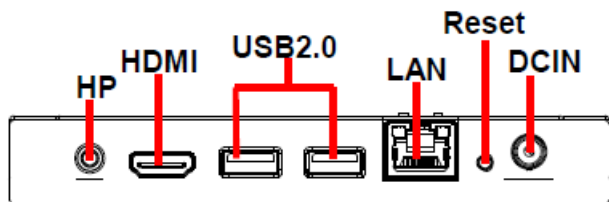

Connectors

Label	Function	Note
SD	Micro SD card slot	
Micro USB	Micro USB connector	
HP	Audio line-out connector	
HDMI	HDMI connector	
USB	2 x USB 2.0 connector	
LAN	RJ-45 Ethernet	
Reset	Reset button	
DCIN	DC power-in connector	

1.5 System Dimensions

1.5.1 Front and Rear side

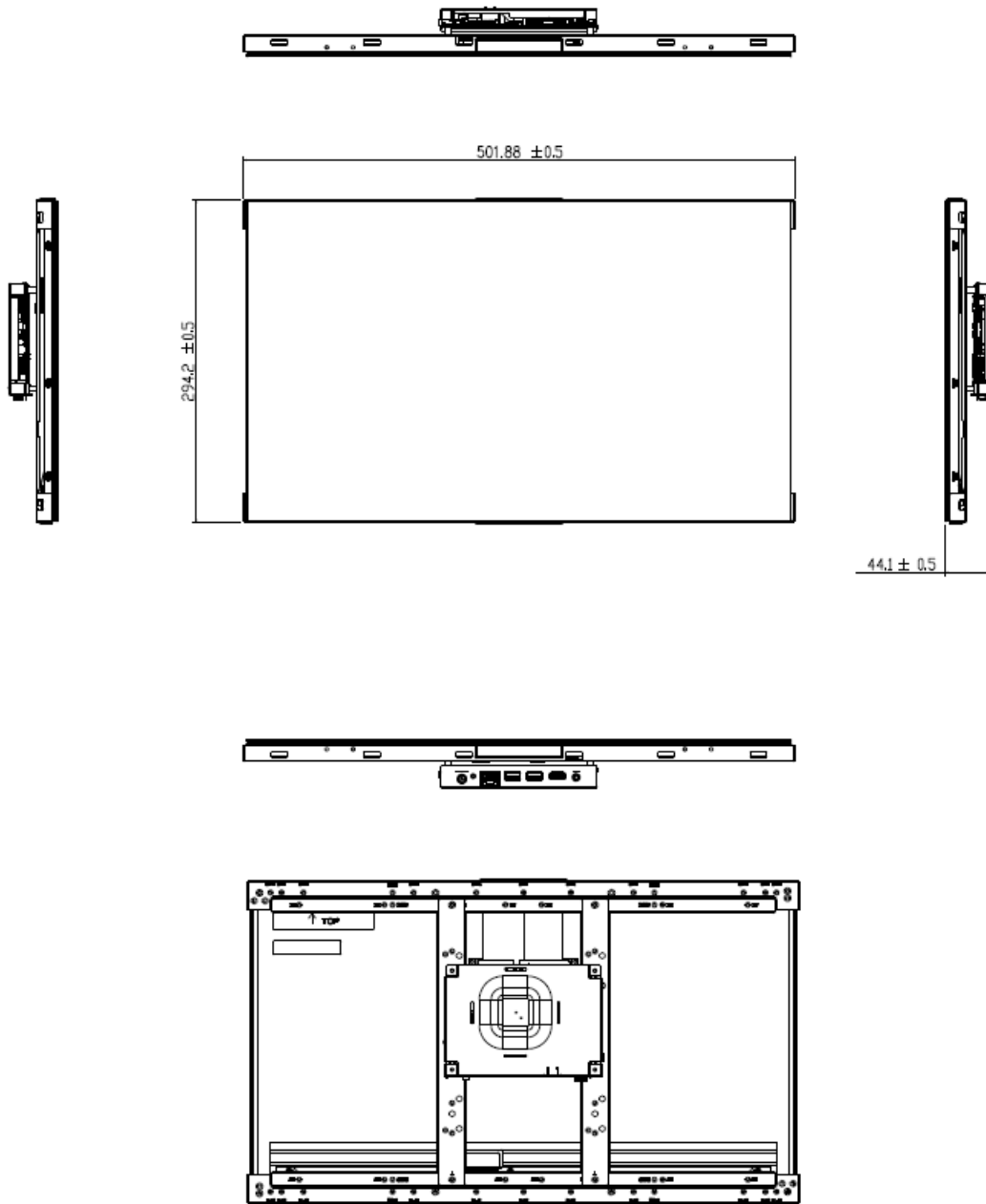

(Unit: mm)

1.5.2 Installing Extend Brackets

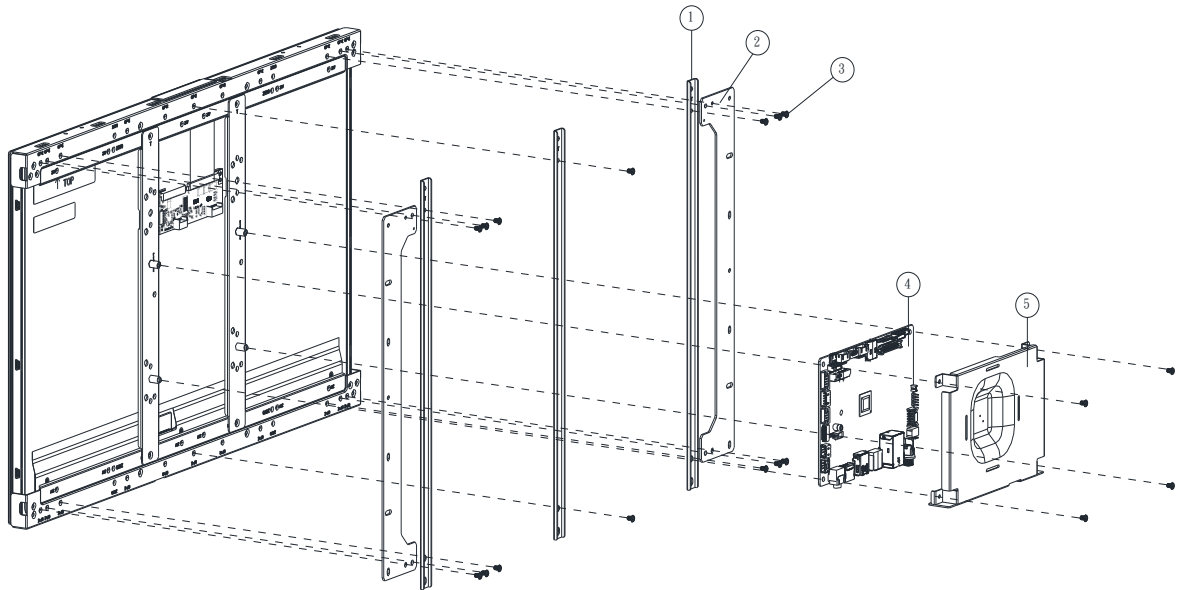

Step1. Locate brackets on both sides, matching the holes on the monitor.

Step2. Insert and fasten 14 screws on each side of the monitor to secure extending brackets.

Step3. Fasten 4 screws to secure PCB & Shielding cover on the OFT-21WR1 bracket.

Note: Brackets sold separately.

4	Screw	14
3	Extending Bracket Bottom	1
2	Extending Bracket TOP	1
1	Extending Bracket RL	2
Item	Part Name	Quantity

1.6 Flush Mounting Concept

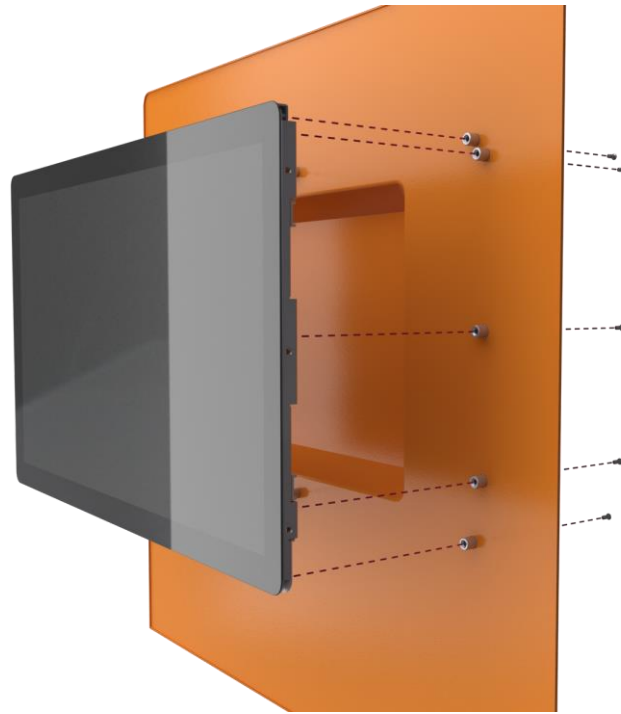

1.7 Panel Mounting

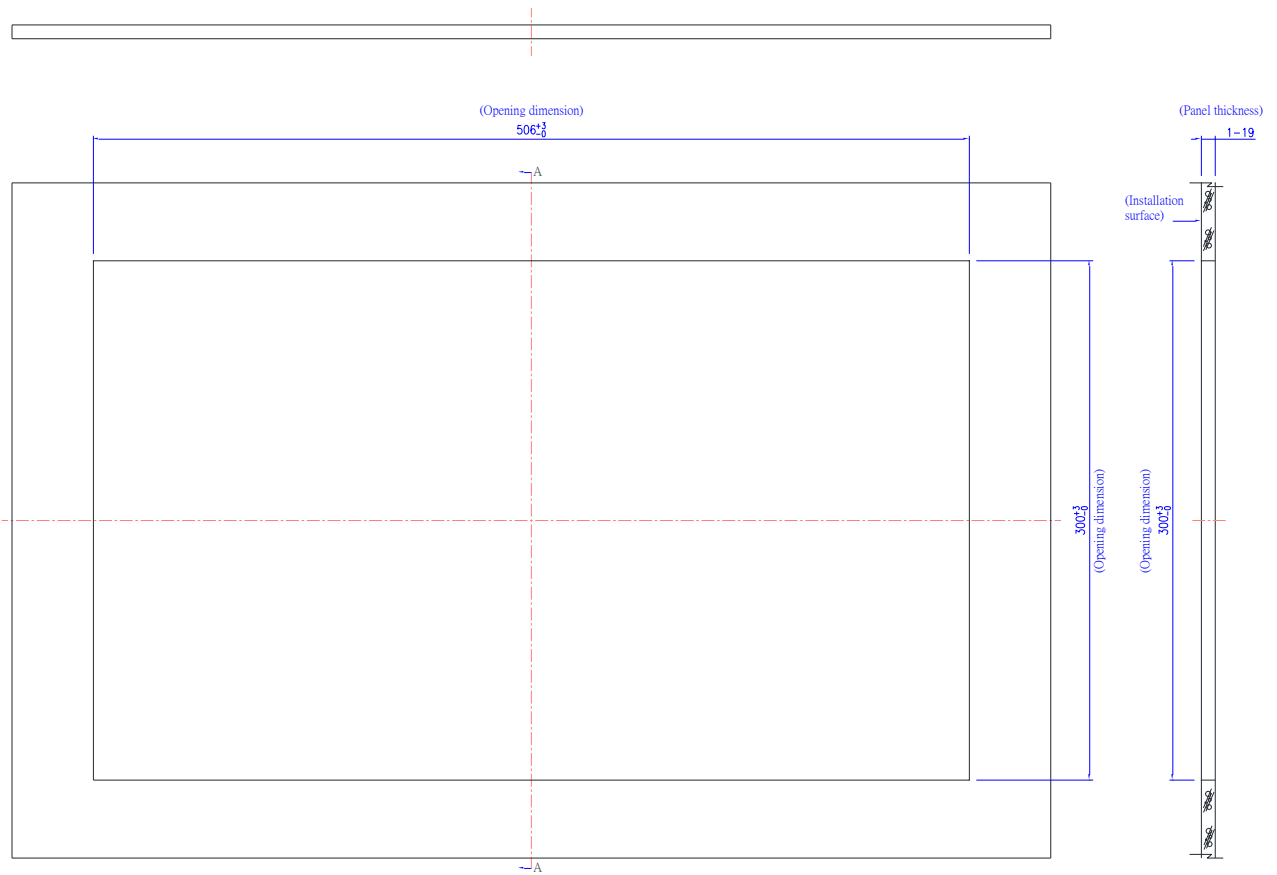

(Unit: mm)

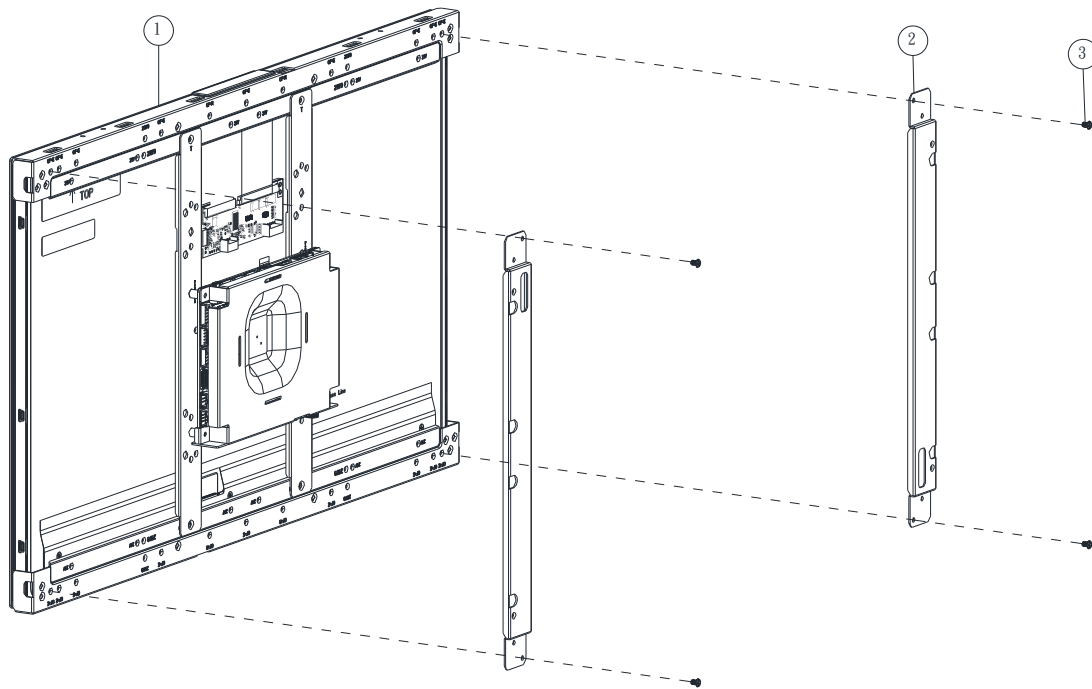

Step1. Insert and fasten 4 screws to secure Bracket R/L.

3	Screw	4
2	Bracket-RL	2
1	21_ASSY	1
Item	Part Name	Quantity

OFT-21WR1

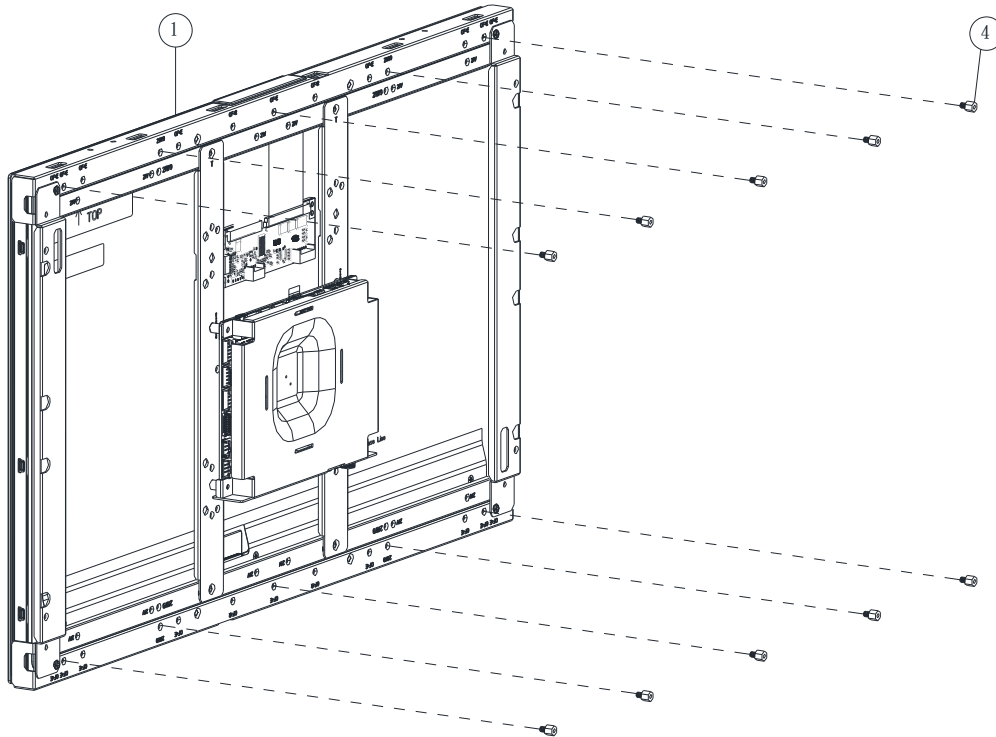

Step2-1. Locate brackets on both sides, matching the holes on the monitor.

Step2-2. Insert and fasten 10 screws on each side of the monitor to secure Mounting brackets.

4	Hexagon Stud	10
1	21_ASSY	1
Item	Part Name	Quantity

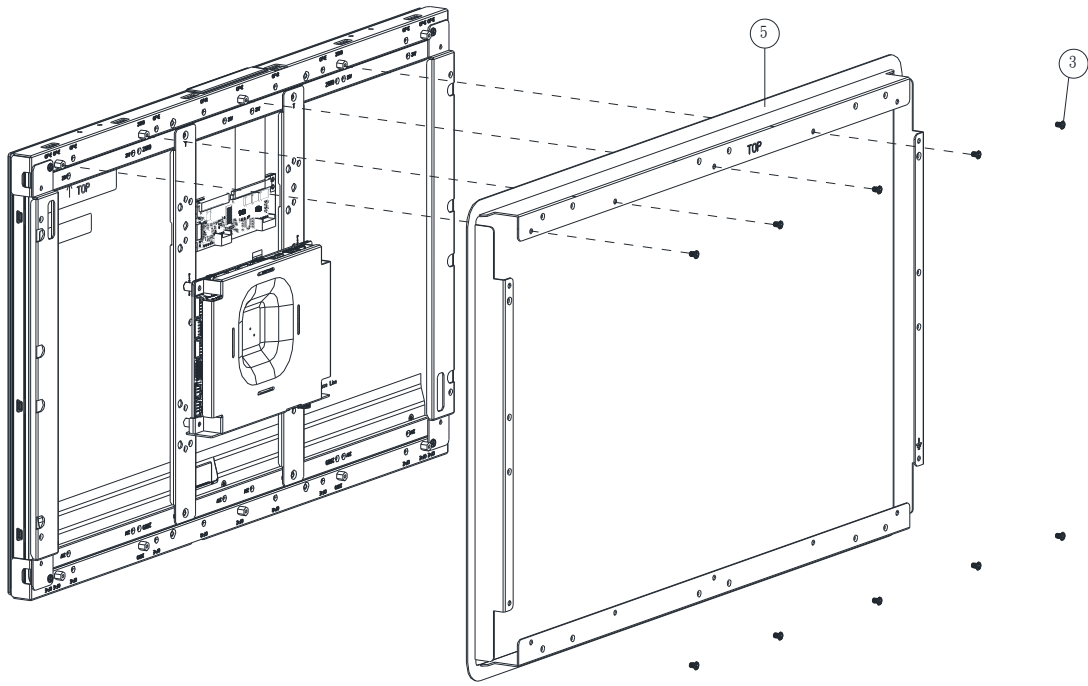

Step3. Insert and fasten 10 screws on each side of the monitor to secure Front bracket.

5	Front Bracket	1
3	Screw	10
Item	Part Name	Quantity

OFT-21WR1

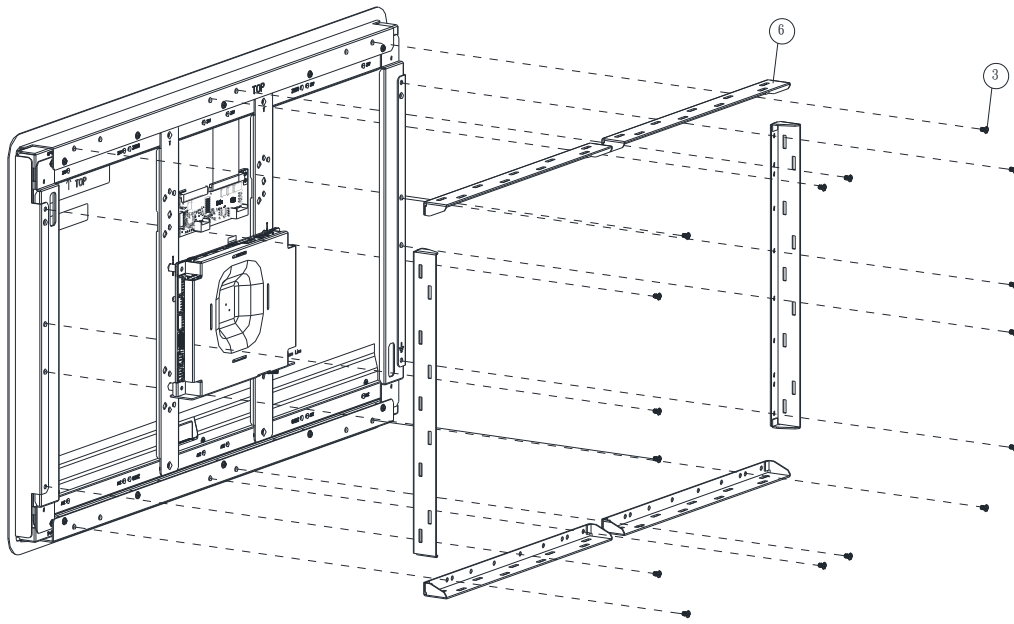

Step4. Insert and fasten 16 screws to secure Bracket.

3	Screw	16
6	Panel Mount Bracket	6
Item	Part Name	Quantity

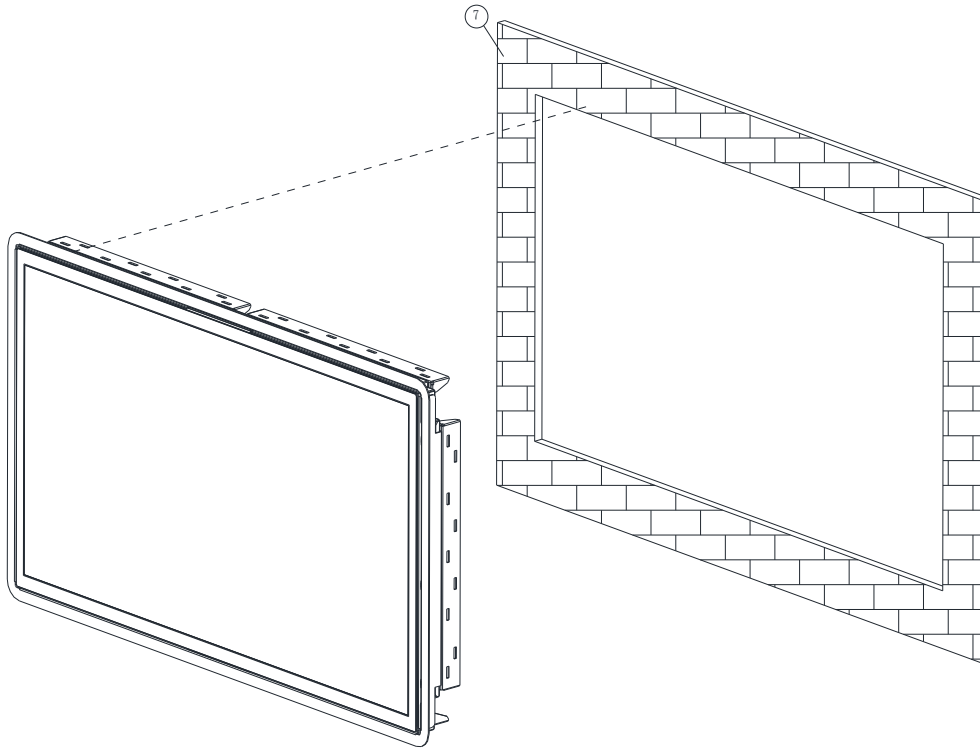

(Outside of the wall)

Step5. Insert OFT-21WR1 into the wall.

7	Wall	1
Item	Part Name	Quantity

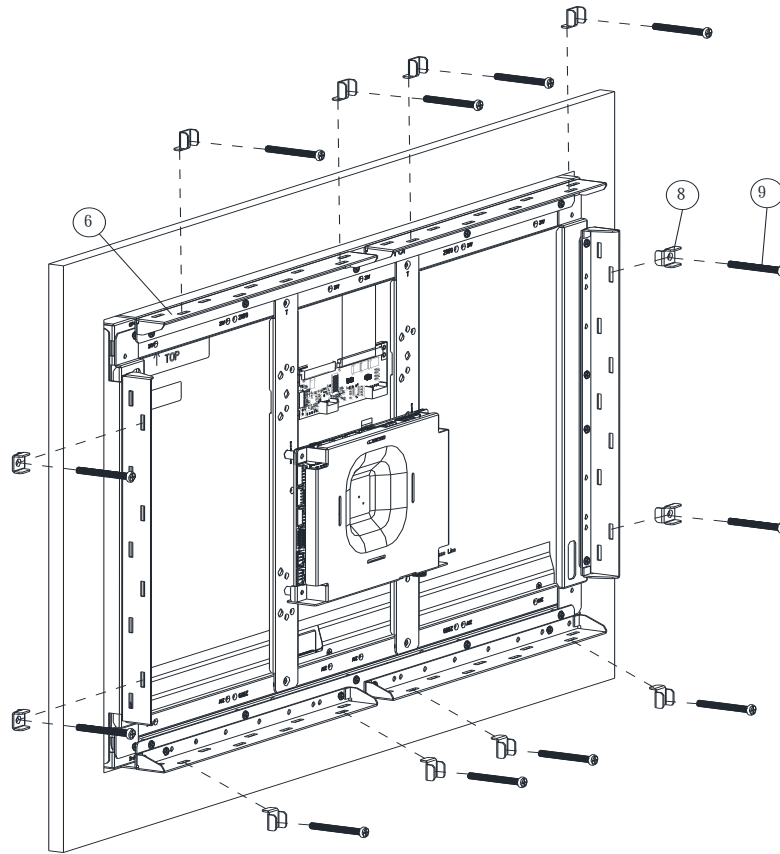

(Inside of the wall)

Step6. Fasten 12 screws to secure Panel mount brackets and insert it into Bracket.

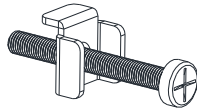

6-1

9	Panel mount Screw	12
8	Panel Mount Kit Bracket	12
6	Panel Mount Bracket	6
Item	Part Name	Quantity

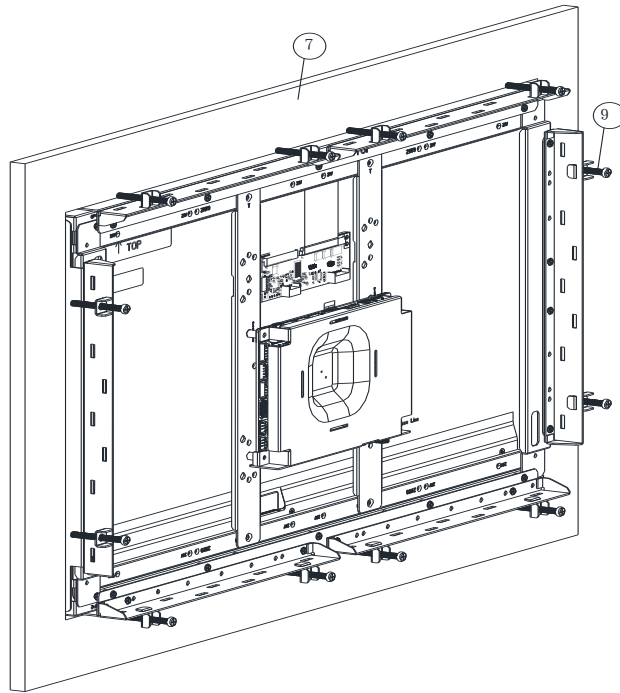

Step7. Insert and fasten 12 Panel mount screws to secure the module.

9	Panel mount Screw	12
7	Wall	1
Item	Part Name	Quantity

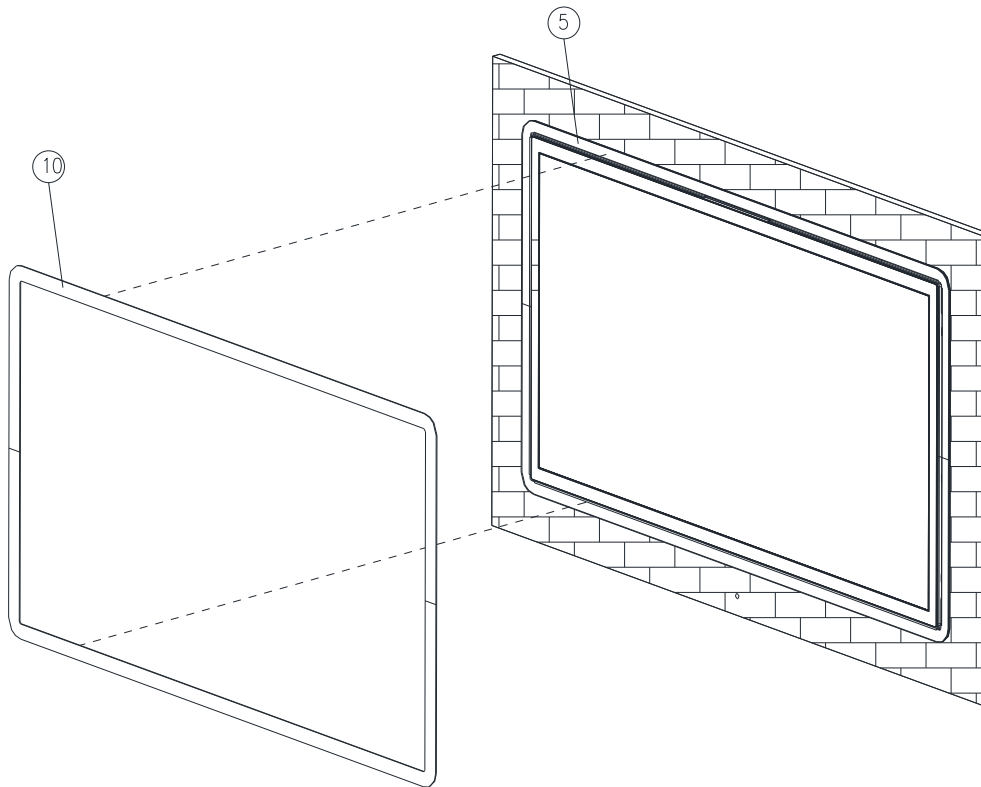

Step8. Paste 2 U Plates on the Front bracket.

10	U Plate	2
5	Front Bracket	1
Item	Part Name	Quantity

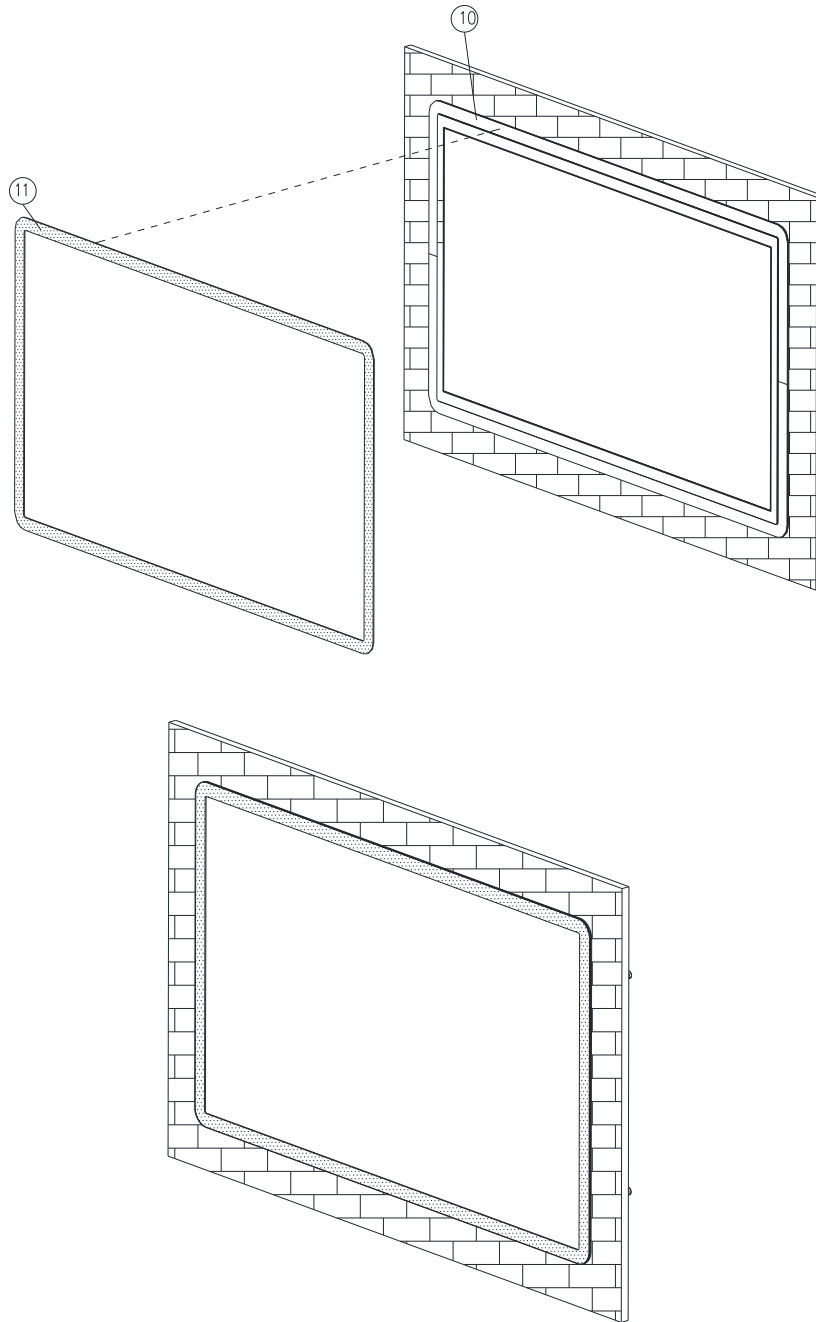

Step9. Paste the Decoration Plate on the U Plate to complete installation.

11	Decoration Plate	1
10	U Plate	2
Item	Part Name	Quantity

1.8 Wall Mounting Concept

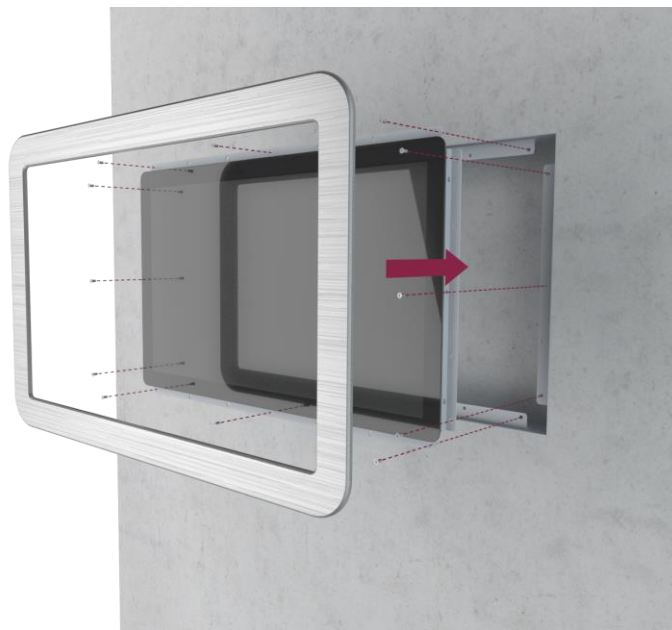
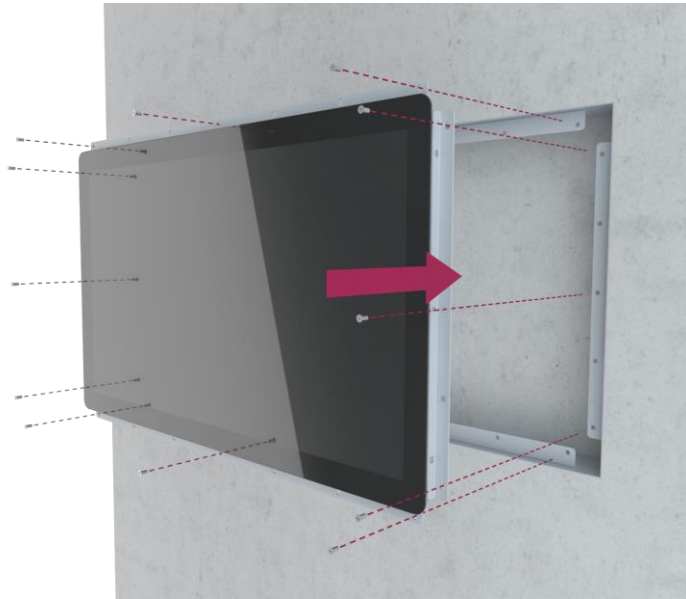

1.9 Wall Mounting

Size of the opening

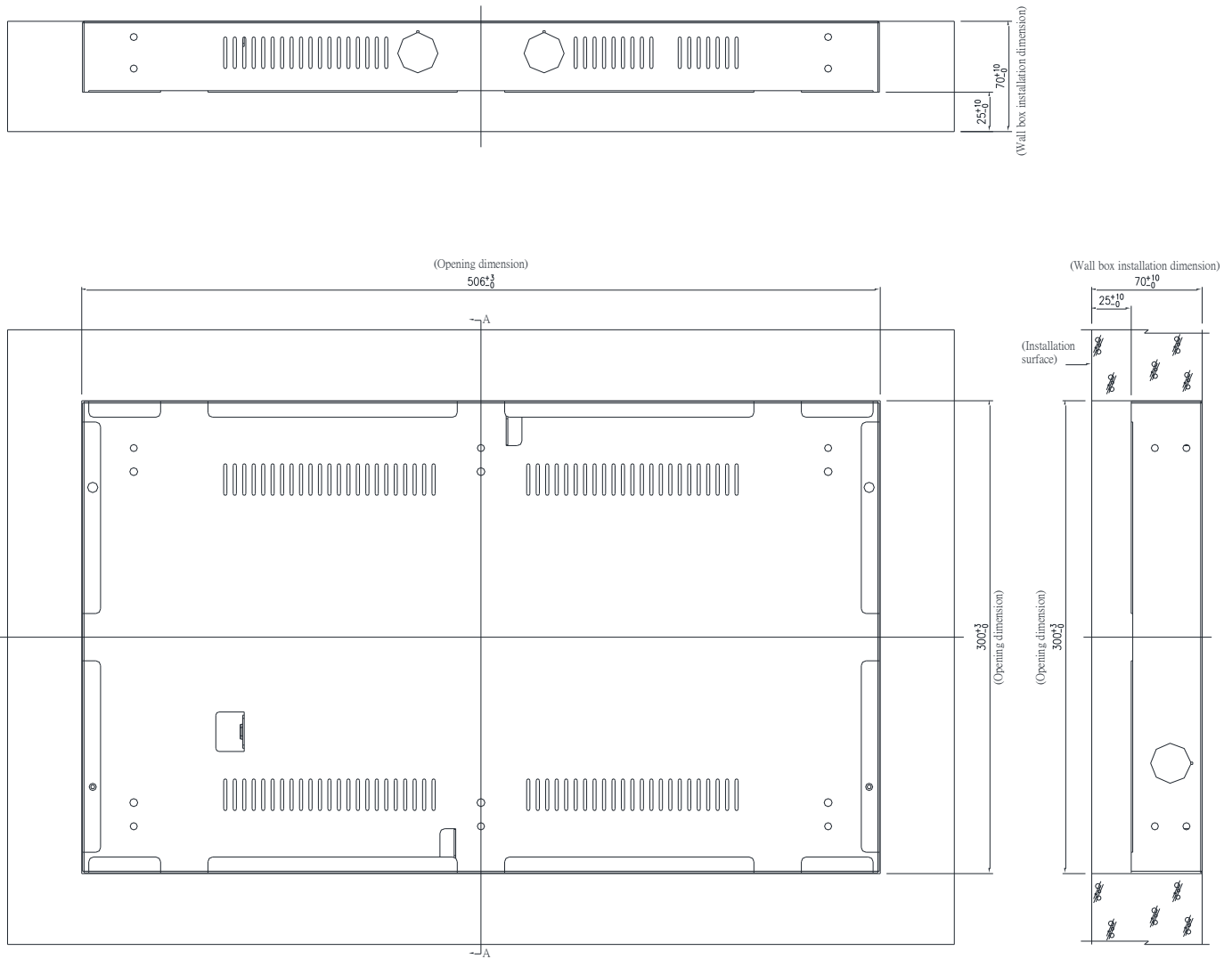

(Unit: mm)

OFT-21WR1

Screw hole location

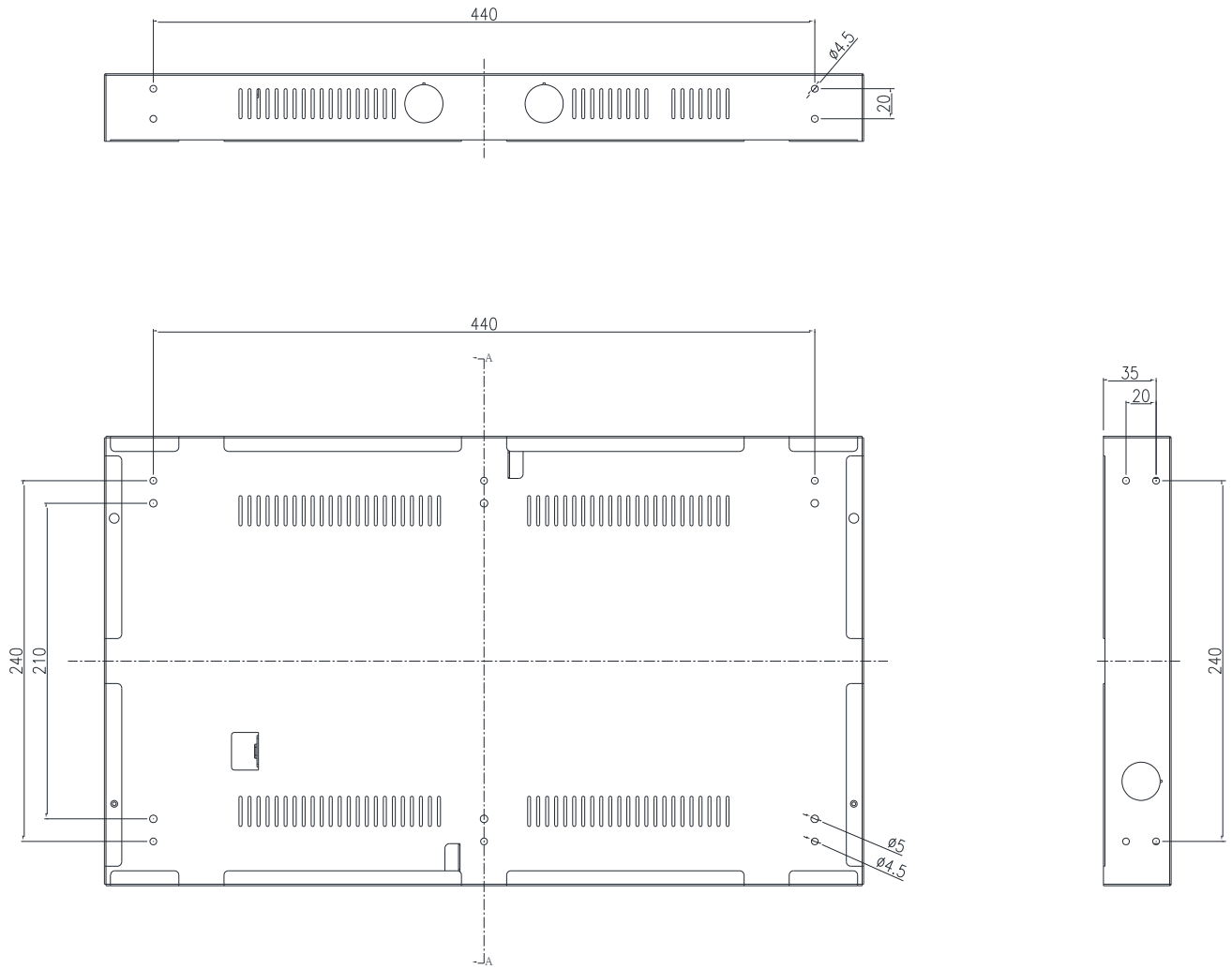

(Unit: mm)

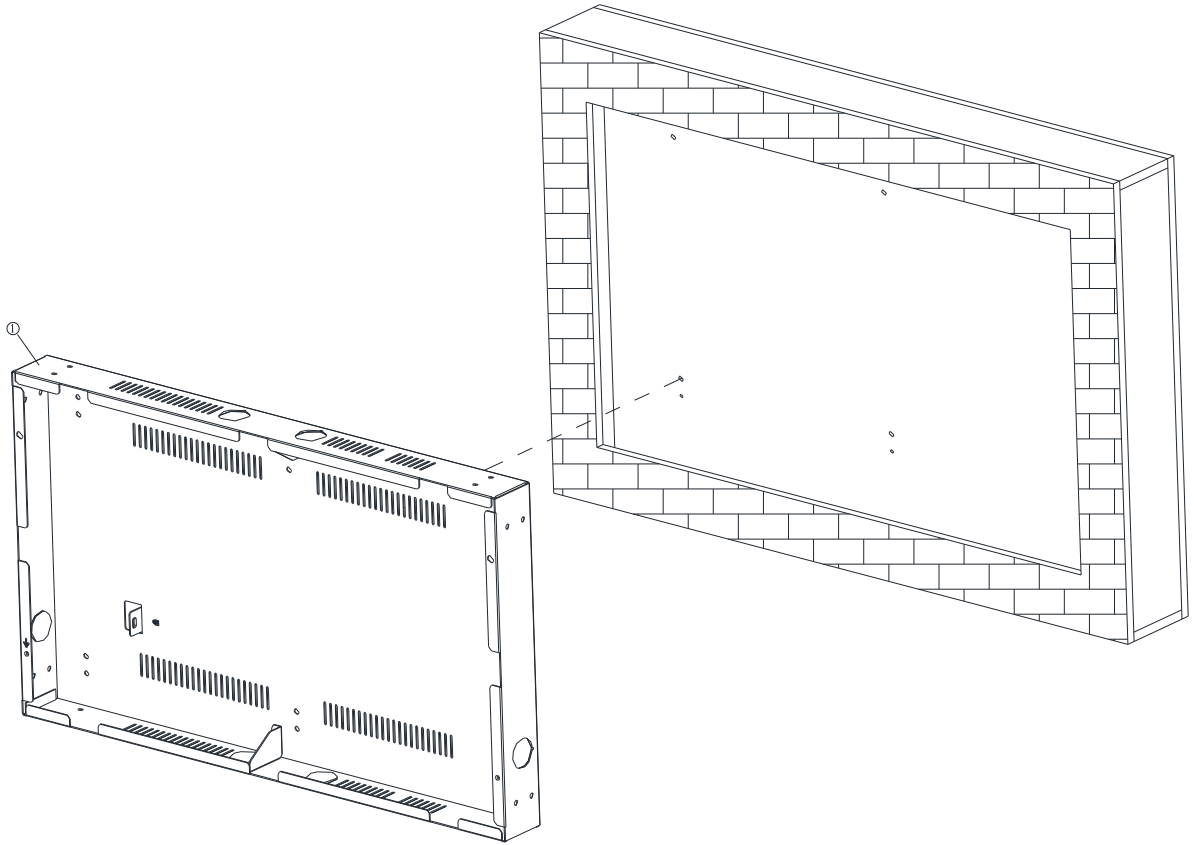

Step1. Fasten the screw on the wall.

1	Wall box	1
Item	Part Name	Quantity

OFT-21WR1

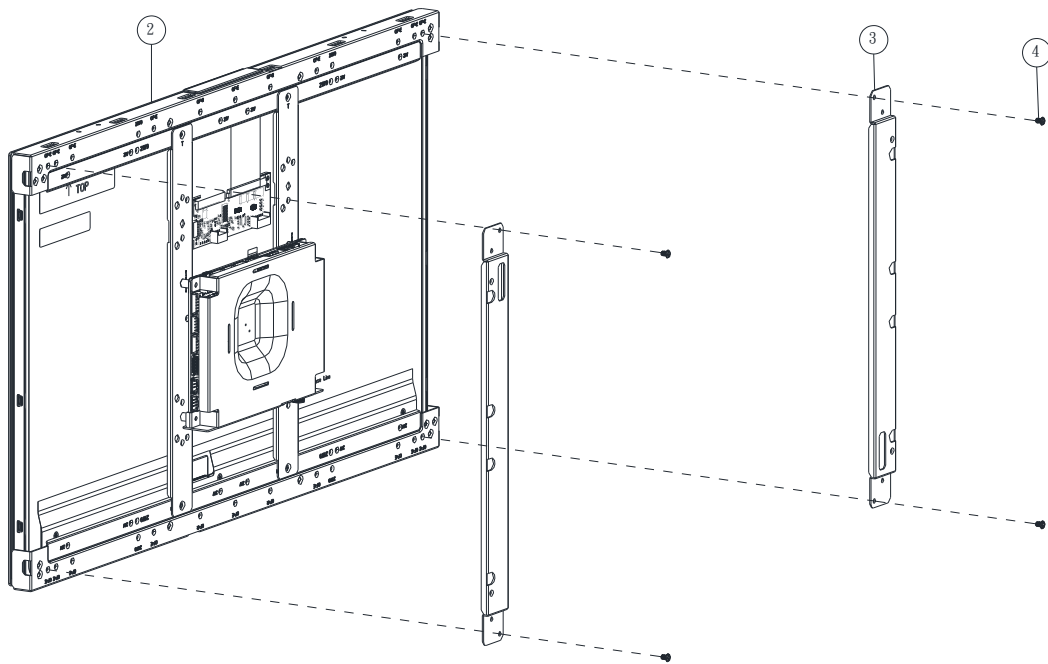

Step2. Insert and fasten 4 screws to secure Bracket R/L.

4	Screw	4
3	Bracket-RL	2
2	21_ASSY	1
Item	Part Name	Quantity

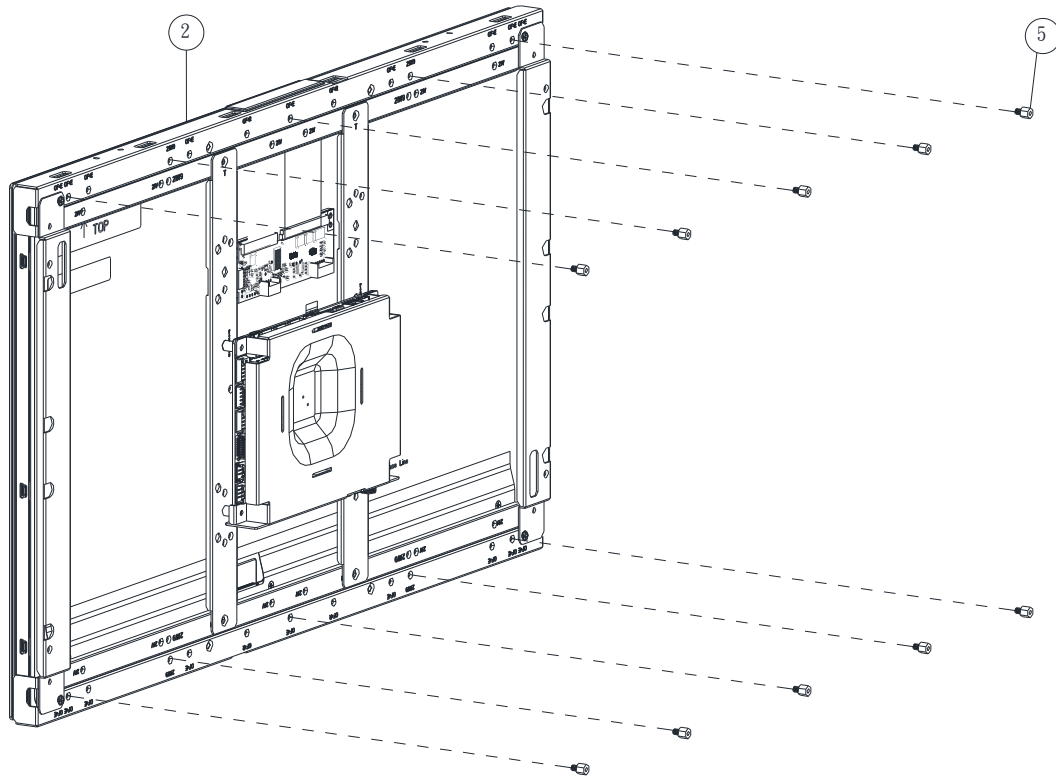

Step3. Insert and fasten 10 screws on each side of the monitor to secure brackets.

5	Hexagon Stud	10
2	21_ASSY	1
Item	Part Name	Quantity

OFT-21WR1

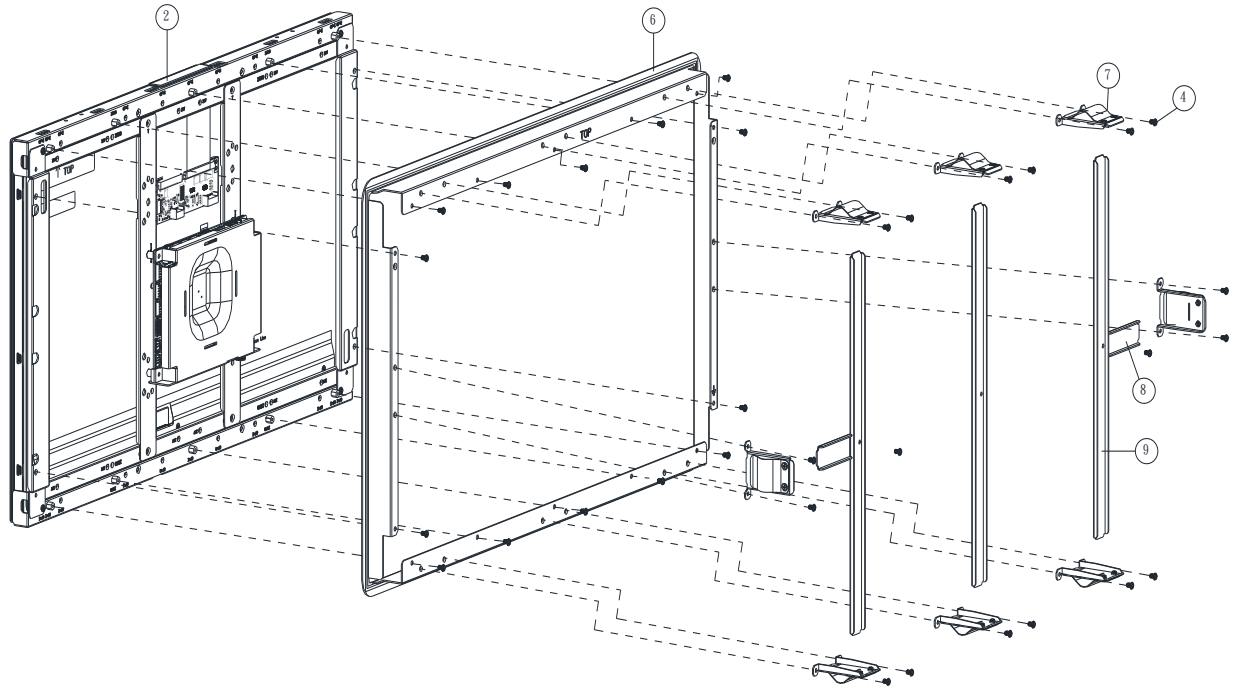

Step4-1. Insert and fasten 14 screws on each side of the monitor to secure Front bracket.

Step4-2. Fasten 6 screws on Front bracket of the monitor to secure Wall mount kit.

Step4-3. Fasten 2 screws on Support Bracket-V (2pcs) of the monitor to secure Support Bracket-H (2pcs).

Step4-4. Insert the Support Bracket-H into the rectangular hole of the locked Wall mount kit.

Insert the Support Bracket-V into the rectangular hole of the Unlocked Wall mount kit and fasten 2 screws to secure Front bracket. (This step is done 3 times in total)

Step4-5. Insert the Support Bracket-H into the rectangular hole of the Wall mount kit and fasten 2 screws to secure Front bracket. (This step is done 2 times in total)

9	Support Bracket-V	3
8	Support Bracket-H	2
7	Wall mount kit	8
4	Screw	31
6	Front bracket	1
Item	Part Name	Quantity

Quick Reference Guide

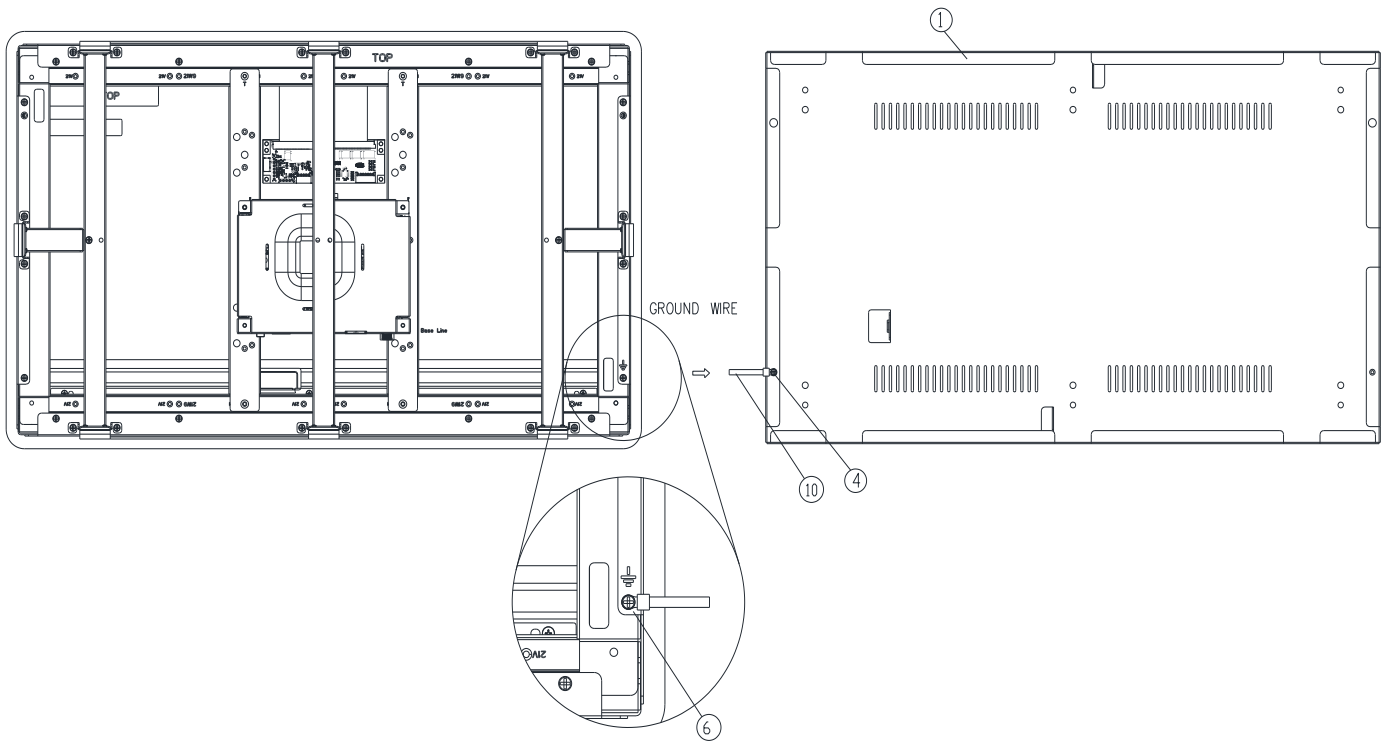

Step5. Insert and fasten 2 screws on Front bracket and Wall box of the monitor to secure Ground wire.

10	Ground wire	1
4	Screw	2
6	Front bracket	1
1	Wall box	1
Item	Part Name	Quantity

OFT-21WR1

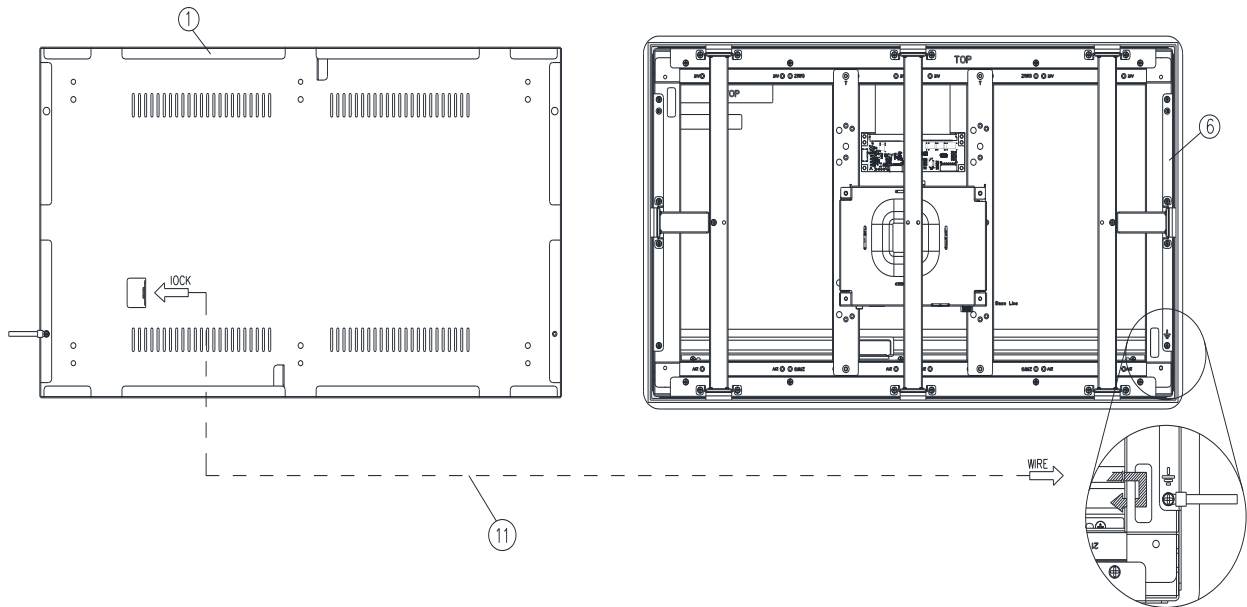

Step6. Wrap the Kensington lock (option) around the hole in the front bracket and attach the lock to the keyhole in the Wall box.

11	Kensington lock	1
6	Front bracket	1
1	Wall box	1
Item	Part Name	Quantity

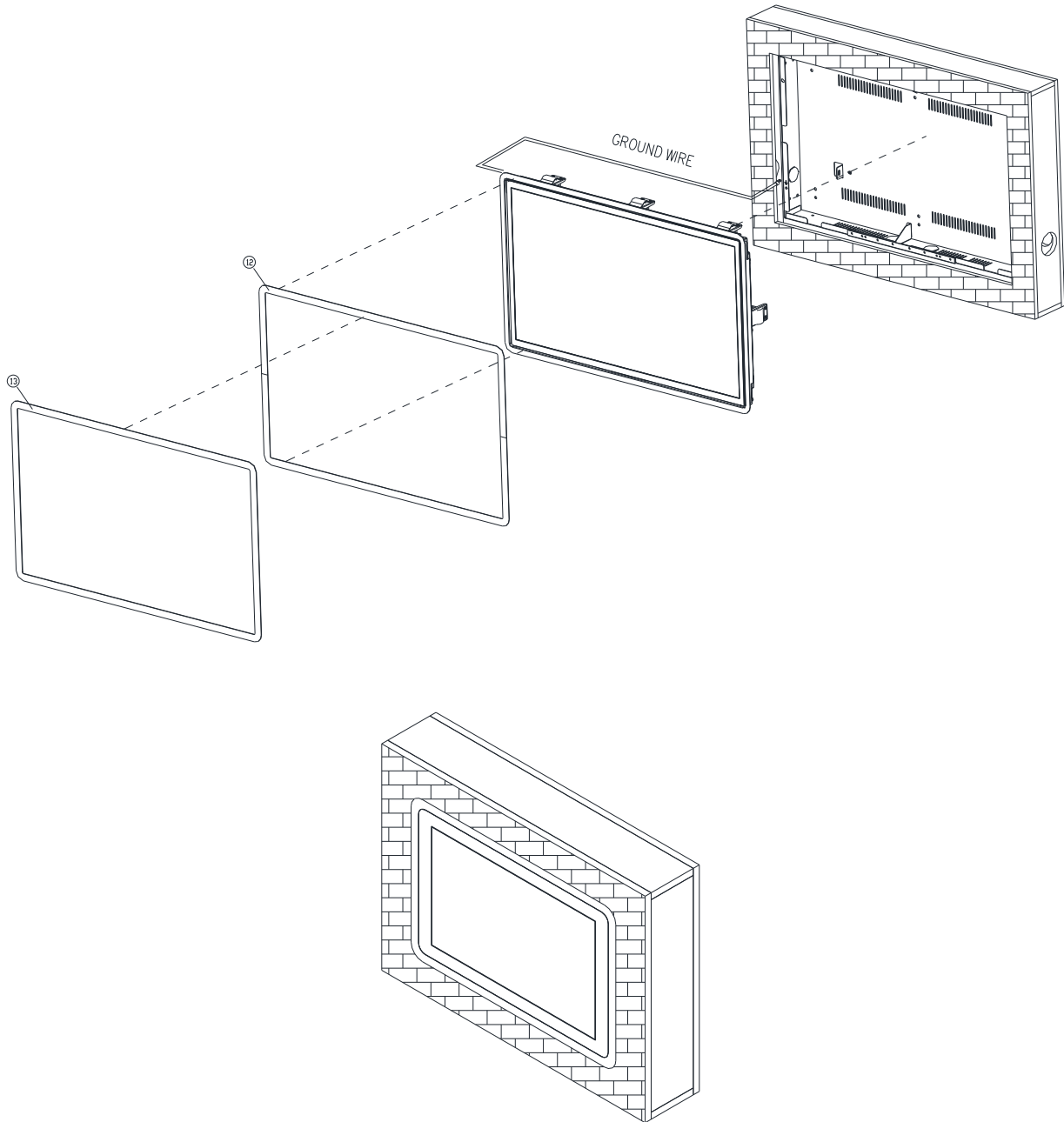

Step7-1. Insert the Ground wire and Kensington lock in the Wall box and Insert OFT-21WR1 into the wall.

Step7-2. Paste the U Bracket (2pcs) on the Front bracket.

Step7-3. Paste the Decoration Plate on the U Bracket to complete installation.

12	U Bracket	2
11	PC bezel	1
Item	Part Name	Quantity

2. Hardware Configuration

For advanced information, please refer to:

- 1- ACP-RK3288B included in this manual.



Note: If you need more information, please visit our website:

<http://www.avalue.com.tw>

2.2 ACP-RK3288B Overviews

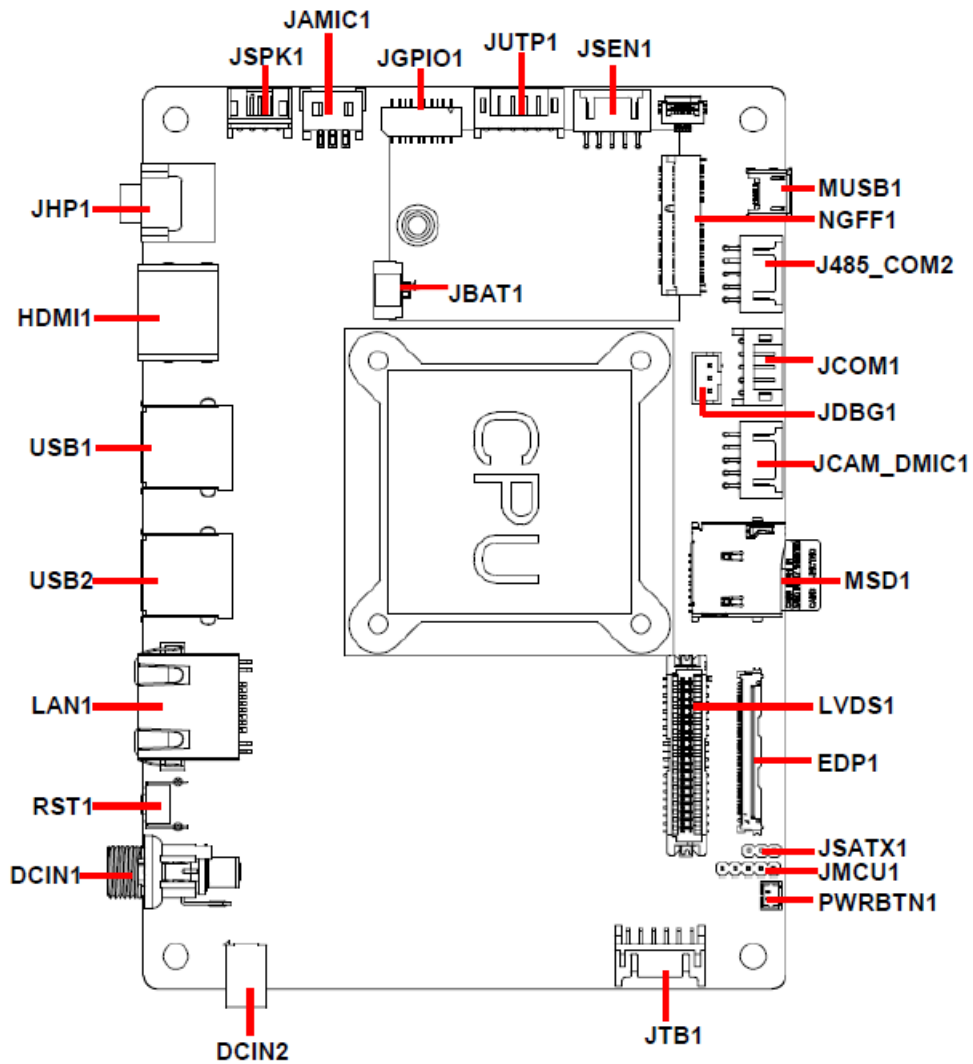

2.3 ACP-RK3288B Connector list

Jumpers

Label	Function	Note
JSATX1	AT/ATX Input power select	3 x 1 header, pitch 2.00 mm

Connectors

Label	Function	Note
JHP1	Audio line-out connector	
HDMI1	HDMI connector	
USB1/2	2 x USB 2.0 connector	
LAN1	RJ-45 Ethernet connector	
DCIN1	DC Power-in connector	
DCIN2	DC Power-in connector	2 x 2 wafer, pitch 2.00 mm
JSPK1	Speaker connector	4 x 1 wafer, pitch 2.00 mm
JUTP1	USB Touch connector	6 x 1 wafer, pitch 2.00 mm
RST1	Reset Button	
NGFF1	M.2 B-Key	
JMCU1	MCU Firmware upgrade connector	5 x 1 header, pitch 2.00 mm
PWRBTN1	Power Button	2 x 1 wafer, pitch 1.25 mm
MSD1	Micro SD card slot	
JBAT1	RTC Battery connector	2 x 1 wafer, pitch 1.25 mm
EDP1	EDP connector	
JSEN1	I2C connector	5 x 2 wafer, pitch 2.00 mm
MUSB1	Micro USB2.0 connector	
JGPIO1	General purpose I/O connector	10 x 2 wafer, pitch 1.00 mm
JCAM_DMIC1	USB Camera connector	5 x 2 wafer, pitch 2.00 mm
JCOM1	Serial port 1 connector	5 x 1 wafer, pitch 2.00 mm
J485_COM2	RS-485 connector	5 x 2 wafer, pitch 2.00 mm
JTB1	Touch button board connector	6 x 2 wafer, pitch 2.00 mm
JAMIC1	A-MIC connector	3 x 1 wafer, pitch 2.00 mm
JDBG1	Debug connector	3 x 1 wafer, pitch 2.00 mm
LVDS1	LVDS connector	DIN 40-pin wafer, pitch 1.25mm Matching Connector: Hirose DF13-40DS-1.25C

JMIPI1

MIPI Port

31 x 1 FPC, pitch 0.30 mm

2.4 Ethernet LED behavior

LAN LED indicator definition

Number	Label	LED color	Indication	Meaning
1	Data Rate	Green/Orange	Off	10 Mbits/sec data rate is selected
			Green on	100 Mbits/sec data rate is selected
			Orange on	1000 Mbits/sec data rate is selected
2	Link/ACT	Yellow	Off	LAN link is not established
			Yellow on	LAN link is established
			Yellow Blinking	LAN active is occurring

2.5 Evaluation Cable Kit (Optional)

Part Number: BCC-OFT-CABLE-02R

Cable List

Cable Function	Spec. Description	Q'ty
RS-232	RS-232 Cable DB-9(M)- 5P/2.0 20cm	1
Debug	Debug cable DB-9(M)-3P/2.0 15cm	1
RS232/RS485	RS232/ RS-485 Cable DB-9(M)- 2x5P/2.0 28cm	1
Switch	Switch/2P/1.25 15cm	1
DC In	Power cable DC JACK4P/2.0 15cm	1
USB Camera/D-MIC	USB Cable 2x5P/2.0 to 8P/0.8 10cm	1
Speaker	2P 4ohm 3W 28*28*13.6 16cm	1
MIC	2P/2.0 , 42db 10cm	1
Keypad	2x6P/2.0	1

*RTC Battery

Warning: Risk of Explosion if Battery is replaced by an Incorrect Type. Dispose of Used Batteries According to the Instructions."

Attention: Risque d'explosion si la batterie est remplacée par un type incorrect. Jetez les piles usagées selon les instructions.

2.6 ACP-RK3288B Jumpers & Connectors settings

2.6.1 AT/ATX Input power select (JSATX1)

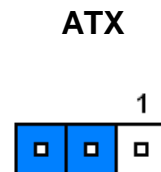
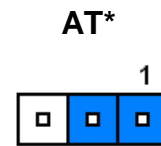
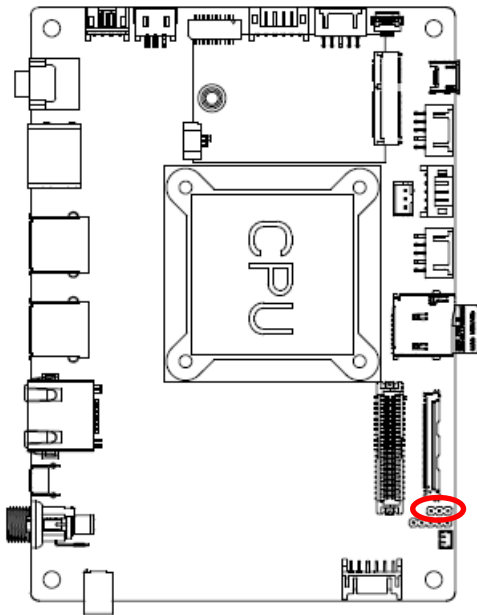

* Default

2.6.2 Touch button board connector (JTB1)

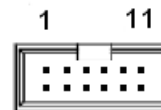
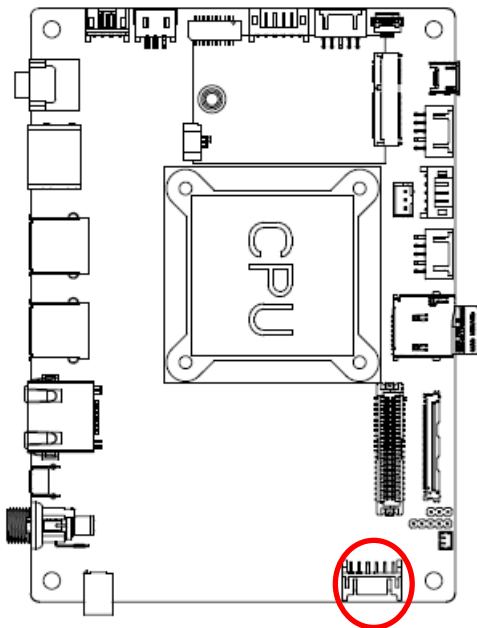

Signal	PIN	PIN	Signal
PWR_TB	1	2	GND
LINUX-SW	3	4	BU1
VOL_UP	5	6	VOL_DN
ONOFF	7	8	BR_UP
BR_DN	9	10	BU7
LED_GRN	11	12	LED_ORG

2.6.3 General purpose I/O connector (JGPIO1)

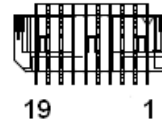
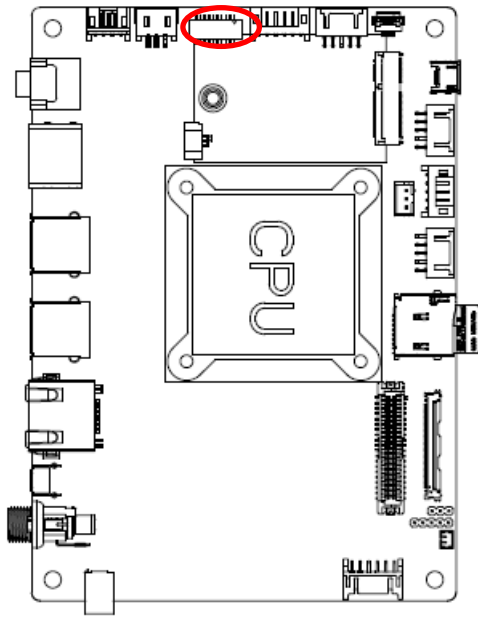

Signal	PIN	PIN	Signal
DIO_GP20	1	2	DIO_GP10
DIO_GP21	3	4	DIO_GP11
DIO_GP22	5	6	DIO_GP12
DIO_GP23	7	8	DIO_GP13
DIO_GP24	9	10	DIO_GP14
DIO_GP25	11	12	DIO_GP15
DIO_GP26	13	14	DIO_GP16
DIO_GP27	15	16	DIO_GP17
DIO_SDA_5V	17	18	DIO_SCL_5V
+V5S_DIOP	19	20	GND

*GPIO number to PIN table

Kernel No.	JGPIO1 Name	Pin No.	Pin No.	JGPIO1 Name	Kernel No.
gpio-280	DIO_GP20	1	2	DIO_GP10	gpio-272
gpio-281	DIO_GP21	3	4	DIO_GP11	gpio-273
gpio-282	DIO_GP22	5	6	DIO_GP12	gpio-274
gpio-283	DIO_GP23	7	8	DIO_GP13	gpio-275
gpio-284	DIO_GP24	9	10	DIO_GP14	gpio-276
gpio-285	DIO_GP25	11	12	DIO_GP15	gpio-277
gpio-286	DIO_GP26	13	14	DIO_GP16	gpio-278
gpio-287	DIO_GP27	15	16	DIO_GP17	gpio-279

2.6.4 RS-485 connector (J485_COM2)

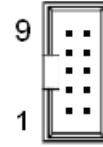
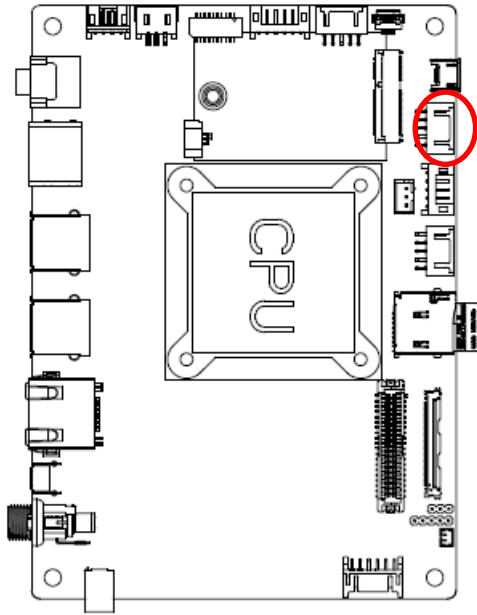

Signal	PIN	PIN	Signal
COM2_TX	1	2	+5V
COM2_RX	3	4	NC
COM2_RTS	5	6	485TX1-
COM2_CTS	7	8	485TX1+
GND	9	10	GND

2.6.5 USB Camera connector (JCAM_DMIC1)

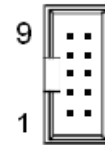
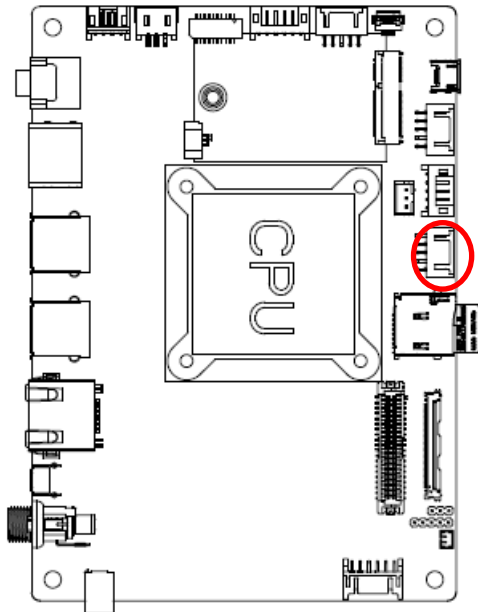

Signal	PIN	PIN	Signal
+VDD_DMIC	1	2	+5V
DMIC_CLK	3	4	USB3_NP
DMIC_DATA	5	6	USB3_PP
GND	7	8	GND
GND	9	10	GND

2.6.6 A-MIC connector (JAMIC1)

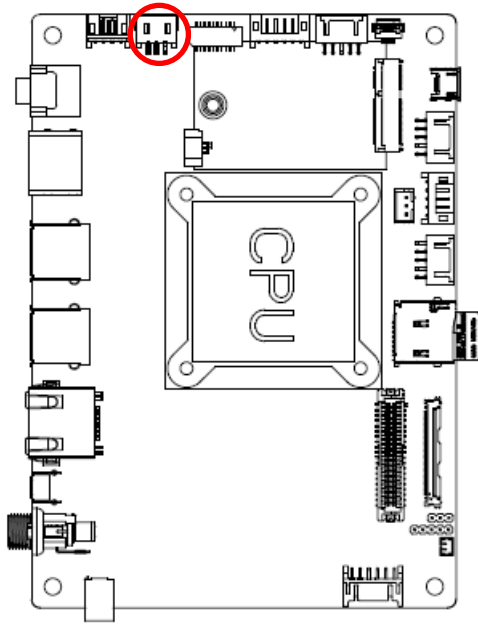

Signal	PIN
MIC_JDET#	1
MIC_INR	2
GND	3

2.6.7 DC Power-in connector (DCIN2)

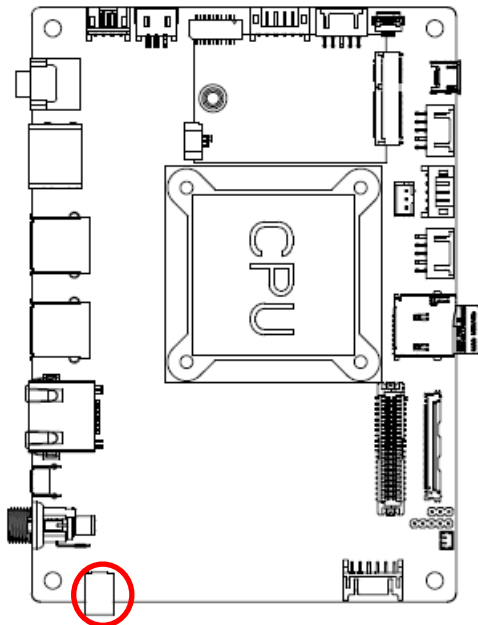

Signal	PIN	PIN	Signal
+VIN	3	4	GND
+VIN	1	2	GND

2.6.8 Speaker connector (JSPK1)

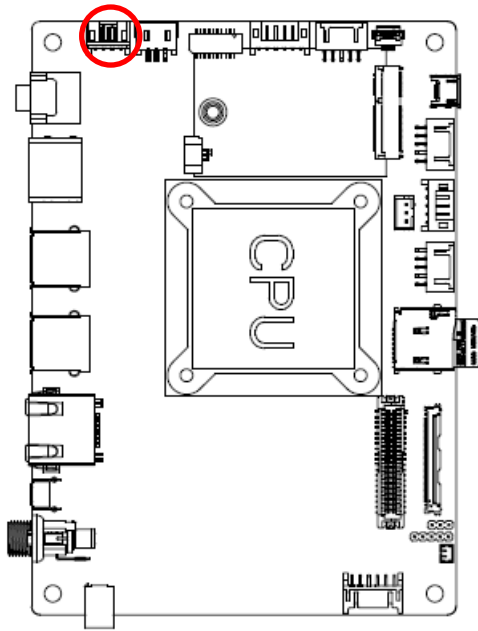

Signal	PIN
SPK_L+	1
SPK_L-	2
SPK_R+	3
SPK_R-	4

2.6.9 I2C connector (JSEN1)

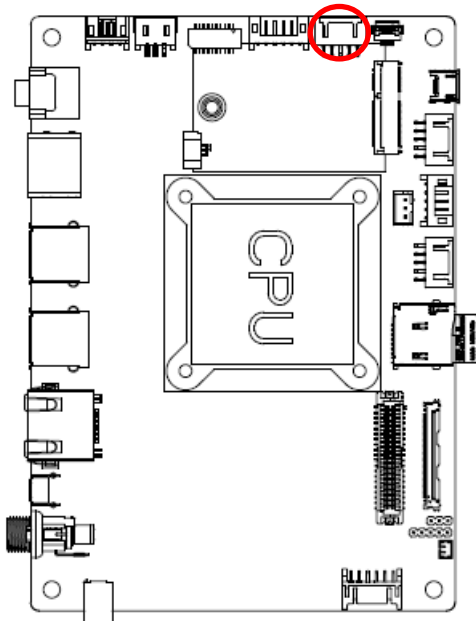

Signal	PIN	PIN	Signal
+3.3V	1	2	+3.3V
SEN1_SCL	3	4	SEN2_SCL
SEN1_SDA	5	6	SEN2_SDA
SEN1_IRQP#	7	8	SEN2_IRQP#
GND	9	10	GND

2.6.10 USB Touch connector (JUTP1)

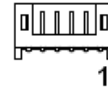
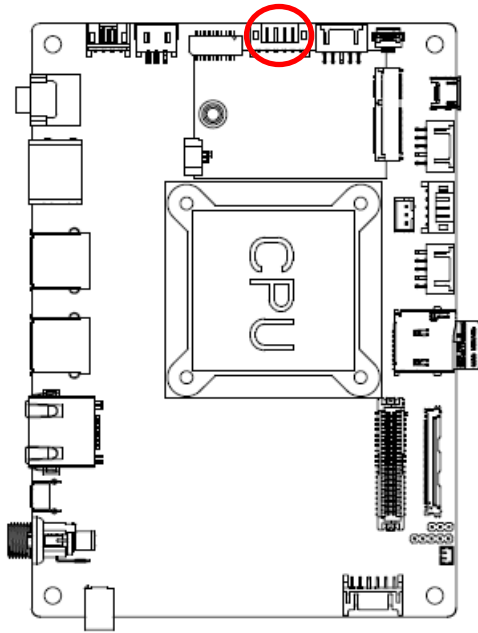

Signal	PIN
+5V	1
USBTP_PP	2
USBTP_NP	3
NC	4
USB_RST_P	5
GND	6

2.6.11 Debug connector (JDBG1)

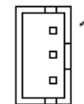
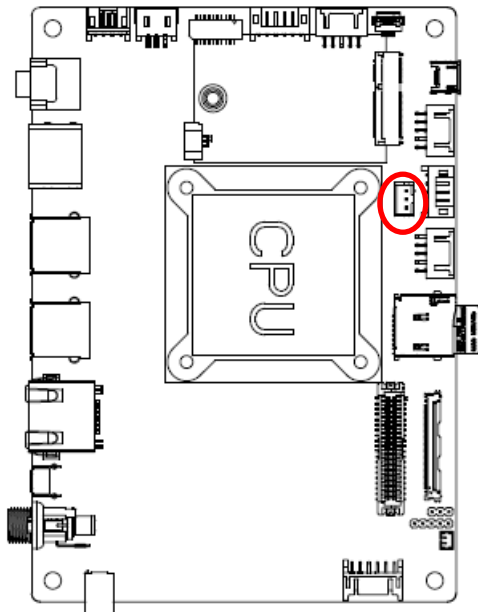

Signal	PIN
CNSL_TX	1
CNSL_RX	2
GND	3

2.6.12 Serial port 1 connector (JCOM1)

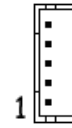
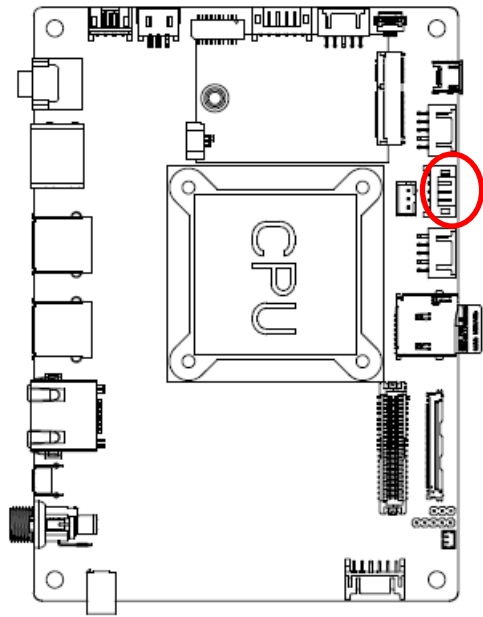

Signal	PIN
GND	5
COM1_CTS	4
COM1_RTS	3
COM1_RX	2
COM1_TX	1

2.6.13 RTC Battery connector (JBAT1)

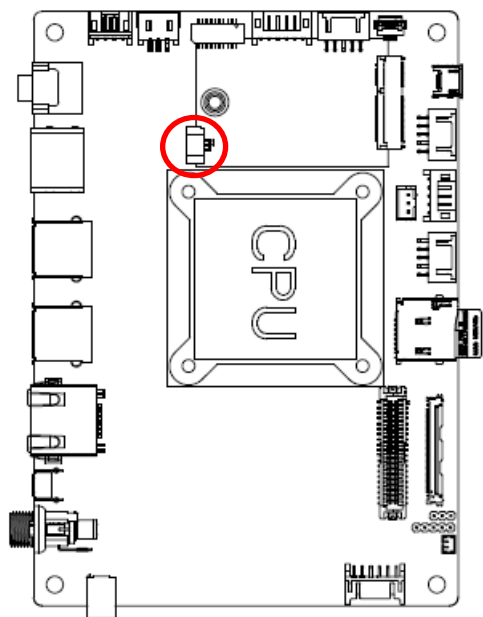

Signal	PIN
+V_BAT	1
GND	2

2.6.14 MCU Firmware upgrade connector (JMCU1)

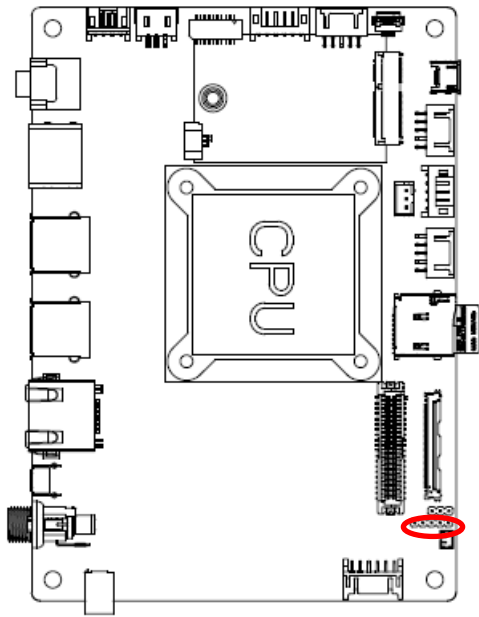

Signal	PIN
+V5MCU	1
MCU_MCLR	2
MCU_ICSPCLK	3
MCU_ICSPDAT	4
GND	5

2.6.15 Power Button (PWRBTN1)

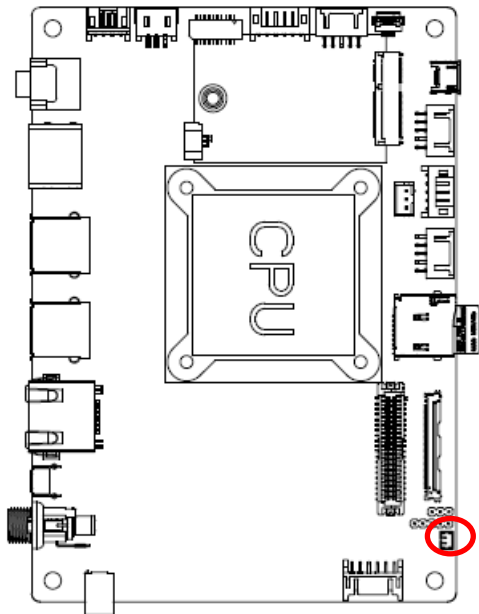

Signal	PIN
PMIC_PWRON#	1
GND	2

2.6.16 LVDS connector (LVDS1)

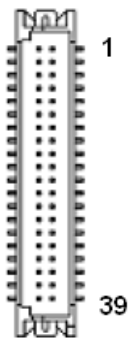
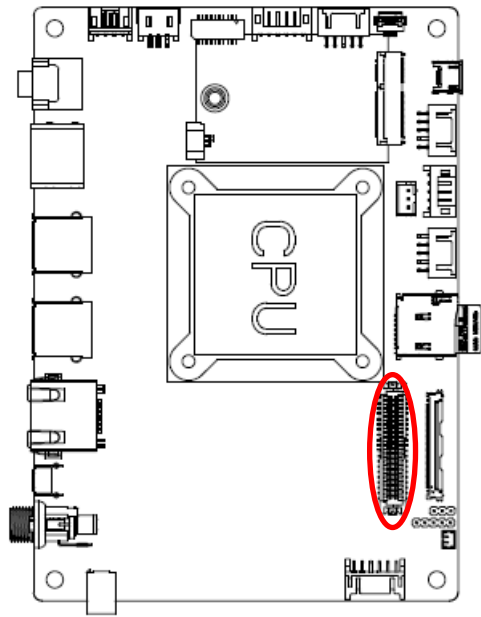

Signal	PIN	PIN	Signal
+5V	2	1	+3.3V
+5V	4	3	+3.3V
NC	6	5	NC
GND	8	7	GND
LVDS0_TX0_P	10	9	LVDS0_TX1_P
LVDS0_TX0_N	12	11	LVDS0_TX1_N
GND	14	13	GND
LVDS0_TX2_P	16	15	LVDS0_TX3_P
LVDS0_TX2_N	18	17	LVDS0_TX3_N
GND	20	19	GND
LVDS_TX5_P	22	21	LVDS_TX6_P
LVDS_TX5_N	24	23	LVDS_TX6_N
GND	26	25	GND
LVDS_TX7_P	28	27	LVDS_TX8_P
LVDS_TX7_N	30	29	LVDS_TX8_N
GND	32	31	GND
LVDS0_CLK_P	34	33	LVDS_CLK1_P
LVDS0_CLK_N	36	35	LVDS_CLK1_N
GND	38	37	GND
+11V2_BKL	40	39	+11V2_BKL

