

OFT-21W03

21.5" Open Frame Tablet

Quick Reference Guide

2nd Ed – 04 August, 2022

Copyright Notice

Copyright © 2022 Avalue Technology Inc., ALL RIGHTS RESERVED.



Federal Communication Commission Interference Statement

THIS DEVICE COMPLIES WITH PART 15 OF THE FCC RULES. OPERATION IS SUBJECT TO THE FOLLOWING TWO CONDITIONS: (1) THIS DEVICE MAY NOT CAUSE HARMFUL INTERFERENCE AND (2) THIS DEVICE MUST ACCEPT ANY INTERFERENCE RECEIVED, INCLUDING INTERFERENCE THAT MAY CAUSE UNDESIRE OPERATION.

Note: This equipment has been tested and found to comply with the limits for a Class A digital device, pursuant to Part 15 of FCC Rules. These limits are designed to provide reasonable protection against harmful interference in a residential installation. This equipment generates, uses and can radiate radio frequency energy and, if not installed and used in accordance with the instruction, may cause harmful interference to radio communications. However, there is no guarantee that interference will not occur in a particular installation. If this equipment does cause harmful interference to radio or television reception, which can be determined by turning the equipment off and on, the user is encouraged to try to correct the interference by one or more of the following measures:

- Reorient or relocate the receiving antenna.
- Increase the separation between the equipment and receiver.
- Connect the equipment into an outlet on a circuit different from that to which the receiver is connected.
- Consult the dealer or an experienced radio/TV technician for help.

Notice:

- (1) A Unshielded-type power cord is required in order to meet FCC emission limits and also to prevent interference to the nearby radio and television reception. It is essential that only the supplied power cord be used.
- (2) Use only shielded cables to connect I/O devices to this equipment.
- (3) Changes or modifications not expressly approved by the party responsible for compliance could void the user's authority to operate the equipment.

FCC RF Radiation Exposure Statement

This Wireless LAN radio device has been evaluated under FCC Bulletin OET 65 and found compliant to the requirements as set forth in CFR 47 Sections 2.1091, 2.1093, and 15.247 (b) (4) addressing RF Exposure from radio frequency devices. The radiated output power of this Wireless LAN device is far below the FCC radio frequency exposure limits. Nevertheless, this device shall be used in such a manner that the potential for human contact during normal operation is minimized. When nearby persons has to be kept to ensure RF exposure compliance, in order to comply with RF exposure limits established in the ANSI C95.1 standards, the distance between the antennas and the user should not be less than 20 cm.

WARNING

“CAUTION – Use suitable mounting apparatus to avoid risk of injury.”

“CAUTION – This is a Class A product. In a domestic environment this product may cause radio interference in which case the user may be required to take adequate measures”

“CAUTION –Risk of explosion if battery is replaced by an incorrect type. Dispose of used batteries according to the instructions.”

“CAUTION - Use a power cord that matches the voltage of the power outlet, which has been approved and complies with the safety standard of your particular country.”

“WARNING – To avoid risk of electric shock, this equipment must only be connected to a supply mains with protective earth.”

Content

1. Getting Started	7
1.1 Safety Precautions	7
1.2 Packing List	7
1.3 System Specifications	8
1.4 System Overview.....	12
1.4.1 Top View	12
1.4.2 Bottom View	12
1.5 System Dimensions.....	13
1.5.1 Front and Rear side	13
1.5.2 Installing Extend Brackets.....	14
1.6 Flush Mounting Concept	15
1.7 Panel Mounting	16
1.8 Wall Mounting Concept.....	26
1.9 Wall Mounting	27
2. Hardware Configuration	36
2.2 Motherboard Overviews.....	37
2.3 Motherboard Connector list.....	38
2.4 Motherboard Jumpers & Connectors settings	40
2.4.1 Clear CMOS (JCMOS1).....	40
2.4.2 Backlight power select (JBLP1)	40
2.4.3 AT/ATX Input power select (JAT1).....	41
2.4.4 DC Power-in connector (JPWR2)	41
2.4.5 Touch Key Button (JTK1).....	42
2.4.6 MCU connector (JMCU1).....	42
2.4.7 Power button (JPB1)	43
2.4.8 Speaker interface (JSPK1).....	43
2.4.9 A-MIC connector (JAMIC1)	44
2.4.10 General purpose I/O connector (JGPIO1).....	44
2.4.11 I2C Touch Panel connector (JTP1).....	45
2.4.12 USB Touch connector (JTP2)	45
2.4.13 I2C Sensor (JSEN1).....	46
2.4.14 Console Debug connector (JCOM1)	46
2.4.15 RS-232 connector (JCOM2).....	47
2.4.16 RS-232 & RS-485 connector (JCOM3).....	47
2.4.17 USB Camera & DMIC connector (JCAM1)	48

OFT-21W03

2.4.18	RTD connector (JRTD1).....	48
2.4.19	LVDS/eDP connector (JLCD1).....	49
2.4.20	Backlight connector 1 (JBL1)	50
2.4.21	Backlight connector 2 (JBL2)	50
2.4.22	RTC battery connector (JBAT1).....	51

1. Getting Started

1.1 Safety Precautions

Warning!



Always completely disconnect the power cord from your chassis whenever you work with the hardware. Do not make connections while the power is on. Sensitive electronic components can be damaged by sudden power surges. Only experienced electronics personnel should open the PC chassis.

Caution!



Always ground yourself to remove any static charge before touching the CPU card. Modern electronic devices are very sensitive to static electric charges. As a safety precaution, use a grounding wrist strap at all times. Place all electronic components in a static-dissipative surface or static-shielded bag when they are not in the chassis.

1.2 Packing List

- 1 x OFT-21W03
- 1 x Screw M3-4mm / ziplock bag No.00 40x60mm x1pc
- 1 x power cord, AC/DC adapter 12V/5A 90 Screw Type (Option)



If any of the above items is damaged or missing, contact your retailer.

1.3 System Specifications

Board Specification	
Mother Board	<ul style="list-style-type: none"> ACP-CHT3
CPU	<ul style="list-style-type: none"> Cherry Trail Z8350 Intel Atom 1.44GHz
CPU Cooler (Type)	<ul style="list-style-type: none"> By mechanical design
Memory	<ul style="list-style-type: none"> 2GB / 4GB DDR3L
Power Supply	<ul style="list-style-type: none"> DC in
Adapter	<ul style="list-style-type: none"> 60W / 12V, 60W / 24V
Microphone	<ul style="list-style-type: none"> 1 x A-MIC interface
Camera	<ul style="list-style-type: none"> 1 x 5P_2mm Camera / DMIC
Speaker	<ul style="list-style-type: none"> 1 x Speaker interface
Wireless LAN	<ul style="list-style-type: none"> 1 x 802.11 b/g/n/ac Wireless LAN
Bluetooth	<ul style="list-style-type: none"> BT 5.0
Operating System	<ul style="list-style-type: none"> Win 10 / Ubuntu 19.04
Storage	
Other Storage Device	<ul style="list-style-type: none"> 32G / 64G eMMC
Panel	
LCD Panel	<ul style="list-style-type: none"> 21.5" Innolux M215HJJ-L30 1920 x 1080
Internal I/O	
Micro USB (Client)	<ul style="list-style-type: none"> JUSBM1: Micro USB_90D
USB Camera & DMIC	<ul style="list-style-type: none"> JCAM1: 5x2P_2mm_90D USB for Camera, Pwr-out(5v,0.5A) Dmic, Pwr-out(1.8v,0.5A)
USB Touch	<ul style="list-style-type: none"> JTP2: 5P_2mm_90D USB for touch screen
M.2 Socket	<ul style="list-style-type: none"> JM2: M.2 B-Key x 1(3042)_90D RST(1.8V), Usb, Uim, Pwr-out(1.8v)
Touch Key Button	<ul style="list-style-type: none"> JTK1: 6x2P_2mm_90D Touch button control(power/vol/brightness...),Led, Reset
DC-IN(wafer)	<ul style="list-style-type: none"> JPWR2: 2x2P_2mm_90D PWR-in 12V~24V
LVDS / eDP	<ul style="list-style-type: none"> JLCD1: 20x2P_1.25mm_180D Lvds dual 24bit, eDP, Hpd, Pwr-out(12v,5v,3.3v) (10.1" / 21.5" _LVDS, 15.6" _eDP)
Analog MIC	<ul style="list-style-type: none"> JAMIC1: 3P_2mm_90D

	<ul style="list-style-type: none"> • Amic, Detect
Speaker	<ul style="list-style-type: none"> • JSPK1: 4P_2mm_90D • L+/L-, R+/R-
Sensor	<ul style="list-style-type: none"> • JSEN1: 5x2P_2mm_90D • I2Cx2/IRQ(3.3V), Pwr-out(3.3v)
Touch Panel	<ul style="list-style-type: none"> • JTP1: 6P_2mm_90D • I2C/INT/RST(3.3V), Pwr-out(3.3v)
Console Debug	<ul style="list-style-type: none"> • JCOM1: 5P_2mm_180D • Pin 1/2 debug • Pin 4/5Uart Rs232(Tx/Rx)
RS232	<ul style="list-style-type: none"> • JCOM2: 5P_2mm_90D • Uart Rs232(Tx/Rx/Rts/Cts)
RS232 & RS485	<ul style="list-style-type: none"> • JCOM3: 5x2P_2mm_90D • Uart Rs232(Tx/Rx/Rts/Cts), Pwr-out(5v) • Uart Rs485
GPIO	<ul style="list-style-type: none"> • JGPIO1: 10x2P_1mm_90D • Gpio 16bit(3.3v), I2c(3.3v), Pwr-out(5v)
RTC Battery	<ul style="list-style-type: none"> • JBAT1: 2P_1.25mm_180D
SIM Card socket	<ul style="list-style-type: none"> • JUIM1: Micro SIM Card socket • for LTE module
Expansion Slots	<ul style="list-style-type: none"> • JSD1: Micro SD slot_90D
External I/O	
DC in Power jack	<ul style="list-style-type: none"> • JPWR1: Power Jack_90D • Pwr-in 12V~24V
HDMI Port	<ul style="list-style-type: none"> • JHDMI-1: HDMI Port_90D
USB Port	<ul style="list-style-type: none"> • JUSB1: USB Type A Host (3.0)_90D • JUSB2: USB Type A Host (2.0)_90D
Lan Port	<ul style="list-style-type: none"> • JLAN1: 10/100 Lan port_90D
Audio Port	<ul style="list-style-type: none"> • JHP1: Headphone Jack_90D
Reset	<ul style="list-style-type: none"> • SRST1: Reset button_90D
Mechanical	
Power Type	<ul style="list-style-type: none"> • 12V~24V wide voltage DC input
Power Connector Type	<ul style="list-style-type: none"> • DC jack
Dimension	<ul style="list-style-type: none"> • 501.88 x 296.2 x 44.1 mm
Weight	<ul style="list-style-type: none"> • 3.4kg
Color	<ul style="list-style-type: none"> • Metallic
Fanless	<ul style="list-style-type: none"> • Yes
OS Support	<ul style="list-style-type: none"> • Win 10 / Ubuntu 19.04

Reliability	
EMI Test	<ul style="list-style-type: none"> • CE • FCC Class A
Safety	<ul style="list-style-type: none"> • IEC62368-1 & EN62368-1
Random Vibration Operation	<ul style="list-style-type: none"> • 1. PSD: 0.00454G²/Hz, 1.5 Grms • 2. Operation mode • 3. Test Frequency : 5-500Hz • 4. Test Axis : X,Y and Z axis • 5. 30 minutes per each axis • 6. IEC 60068-2-64 Test:Fh • 7. Storage : CF or SSD
Sine Vibration Test (Nonoperation)	<ul style="list-style-type: none"> • 1 Test Acceleration : 2G • 2 System condition: Non-Operating mode • 3 Test frequency : 5~500 Hz • 4 Sweep : 1 Oct/ per one minute. (logarithmic) • 5 Test Axis : X,Y and Z axis • 6 Test time : 10 min. each axis • Reference IEC 60068-2-6 Testing procedures
Package vibration test	<ul style="list-style-type: none"> • 1. PSD: 0.026G²/Hz , 2.16 Grms • 2. Non-operation mode • 3. Test Frequency : 5-500Hz • 4. Test Axis : X,Y and Z axis • 5. 30 min. per each axis • 6. IEC 60068-2-64 Test:Fh
Bump Test	<ul style="list-style-type: none"> • 1. Wave form : Half Sine wave • 2. Acceleration Rate : 10g for operation mode • 3. Duration Time : 11ms • 4. No. of Shock : Z axis 300 times • 5. Test Axis: Z axis • 6. Operation mode • 7. Reference IEC 60068-2-29 Testing procedures • Test Eb : Shock Test
Package Drop Test	<ul style="list-style-type: none"> • One corner, three edges, six faces • ISTA 2A, IEC-60068-2-32 Test: Ed
Operating Temperature	<ul style="list-style-type: none"> • 0°C ~ 40°C
Operating Humidity	<ul style="list-style-type: none"> • 40°C @ 95% Relative Humidity, Non-condensing
Storage Temperature	<ul style="list-style-type: none"> • -20°C ~ 60°C



Note: Specifications are subject to change without notice.

1.4 System Overview

1.4.1 Top View

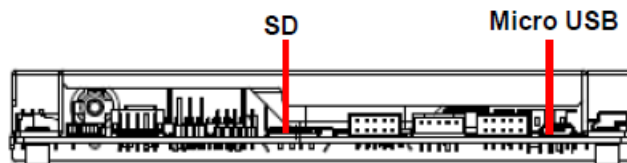

1.4.2 Bottom View

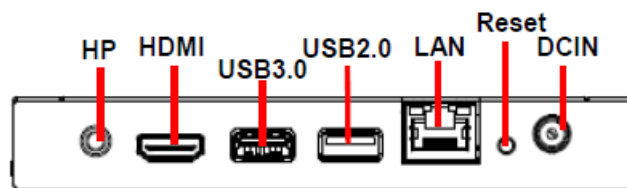

Connectors

Label	Function	Note
SD	Micro SD card slot	
Micro USB	Micro USB connector	
HP	Audio line-out connector	
HDMI	HDMI connector	
USB	1 x USB 3.0 connector 1 x USB 2.0 connector	
LAN	RJ-45 Ethernet	
Reset	Reset button	
DCIN	DC power-in connector	

1.5 System Dimensions

1.5.1 Front and Rear side

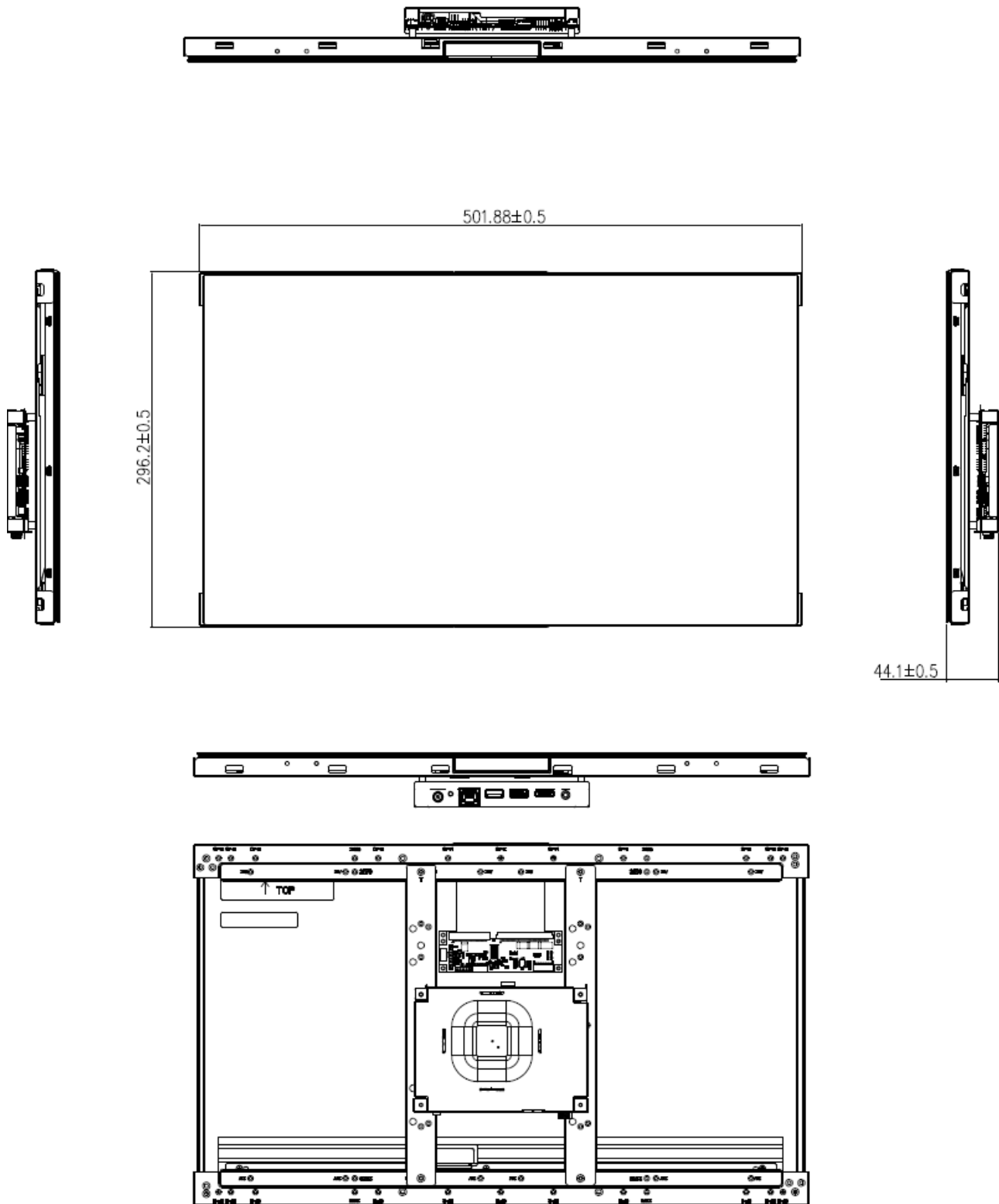

(Unit: mm)

1.5.2 Installing Extend Brackets

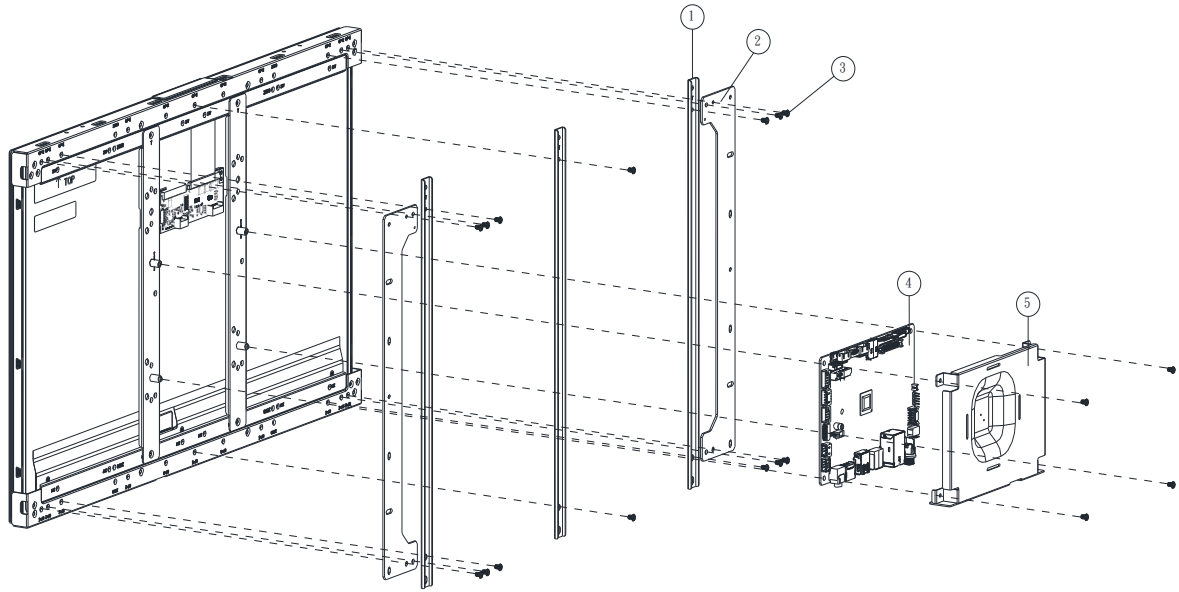

Step1. Locate brackets on both sides, matching the holes on the monitor.

Step2. Insert and fasten 14 screws on each side of the monitor to secure extending brackets.

Step3. Fasten 4 screws to secure PCB & Shielding cover on the OFT-21W03 bracket.

Note: Brackets sold separately.

5	Screw	18
4	Shielding cover	1
3	PCB	1
2	Extending bracket RL	2
1	Extending bracket	3
Item	Part Name	Quantity

1.6 Flush Mounting Concept

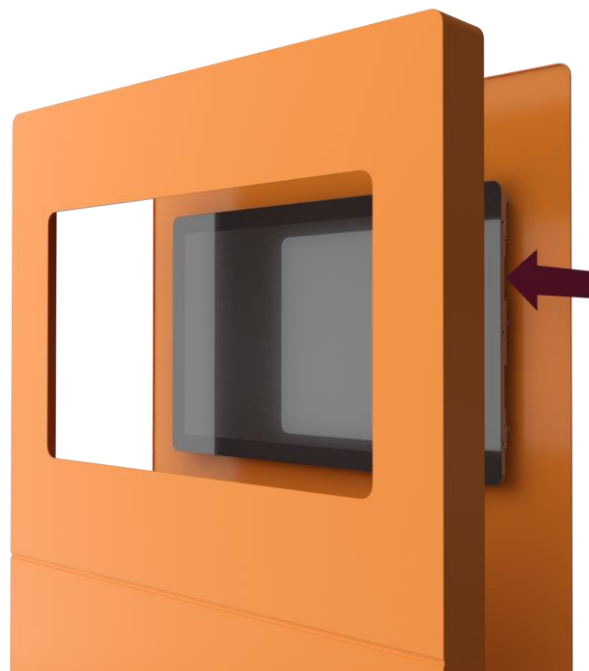
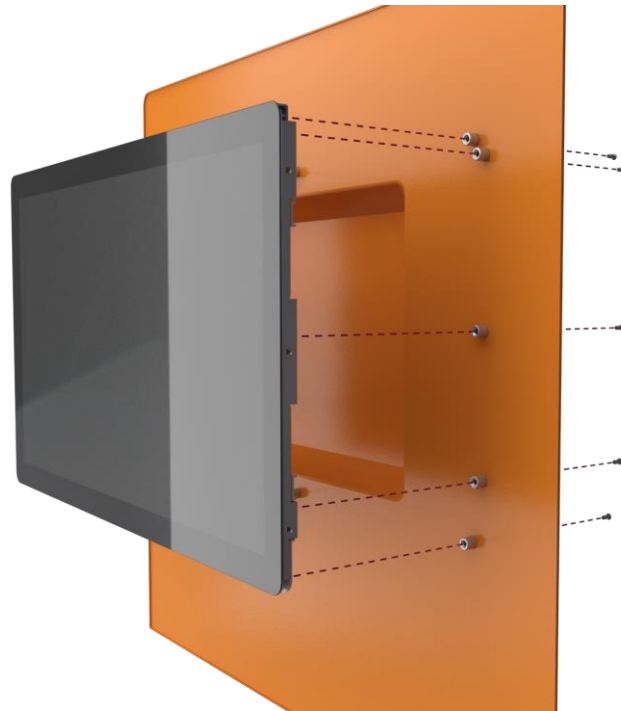

1.7 Panel Mounting

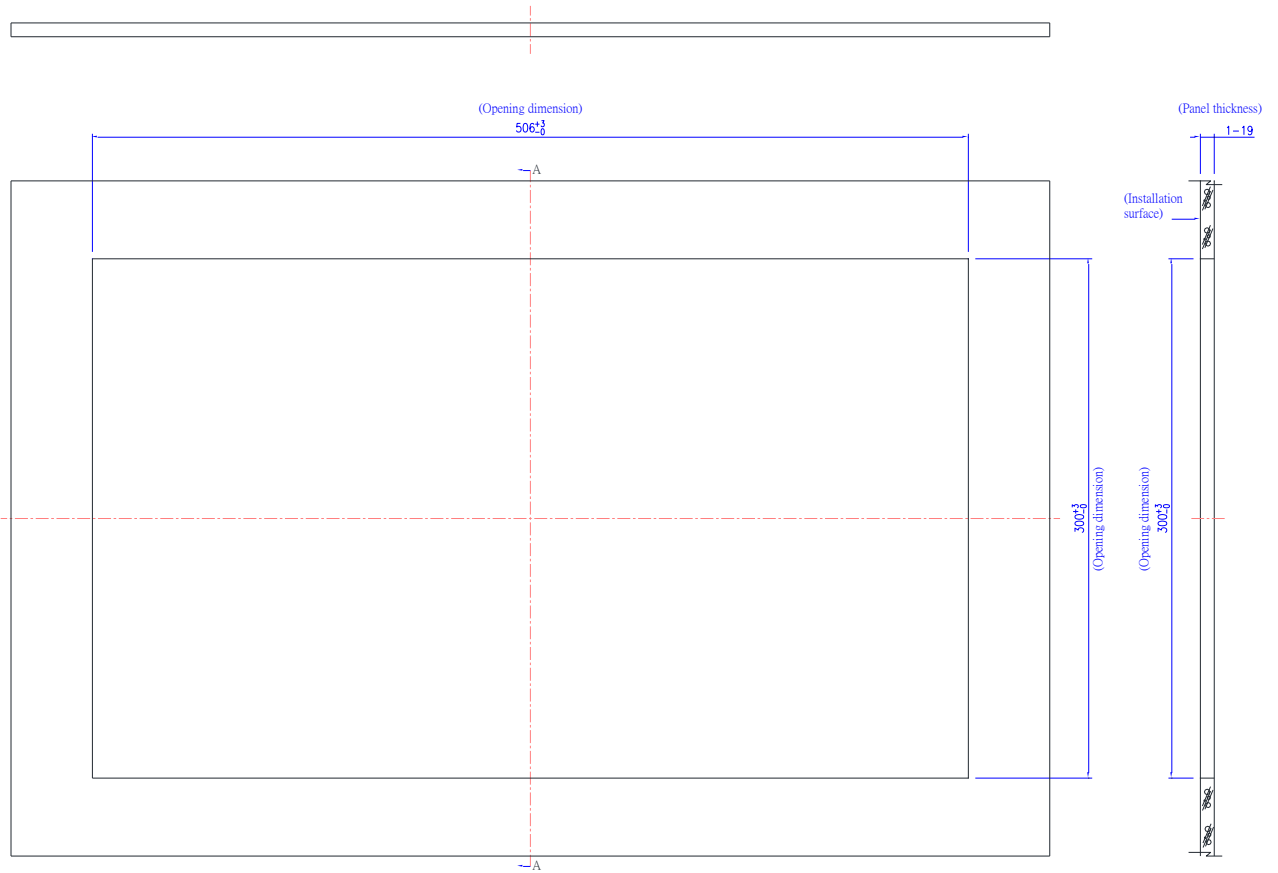

(Unit: mm)

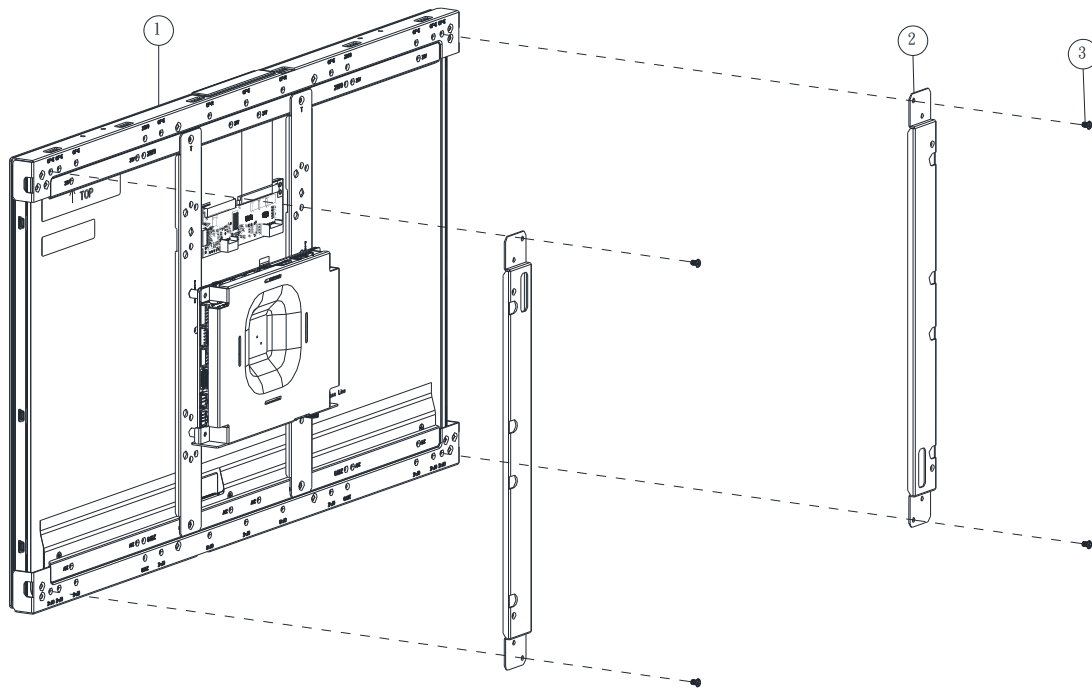

Step1. Insert and fasten 4 screws to secure Bracket R/L.

3	Screw	4
2	Bracket-RL	2
1	21_ASSY	1
Item	Part Name	Quantity

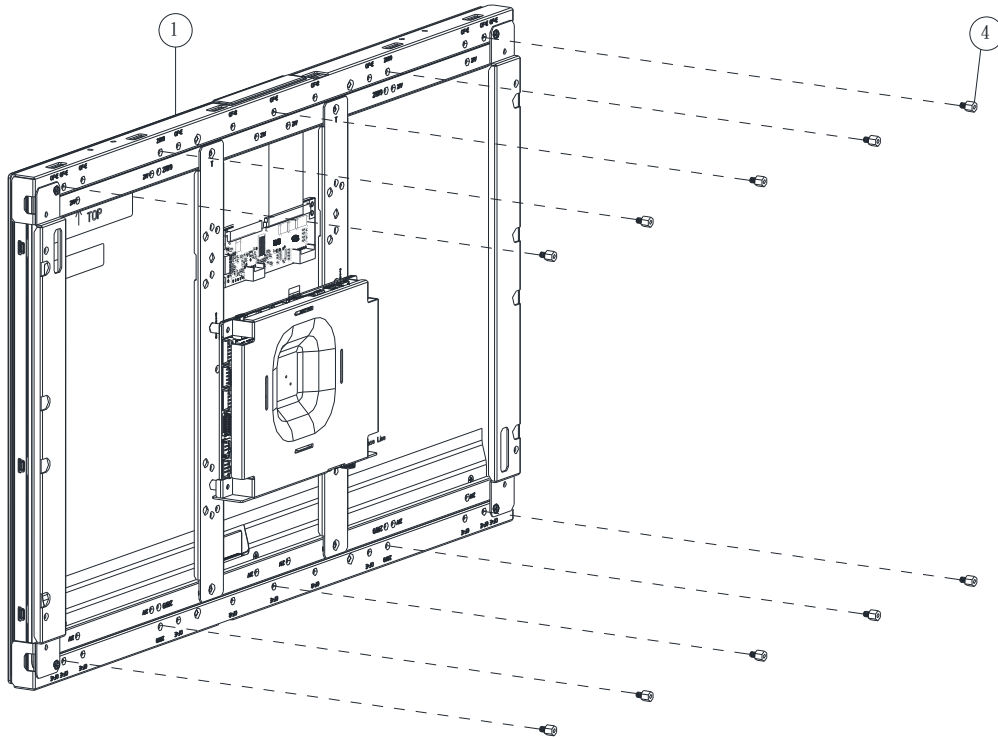

Step2-1. Locate brackets on both sides, matching the holes on the monitor.

Step2-2. Insert and fasten 10 screws on each side of the monitor to secure Mounting brackets.

4	Hexagon Stud	10
1	21_ASSY	1
Item	Part Name	Quantity

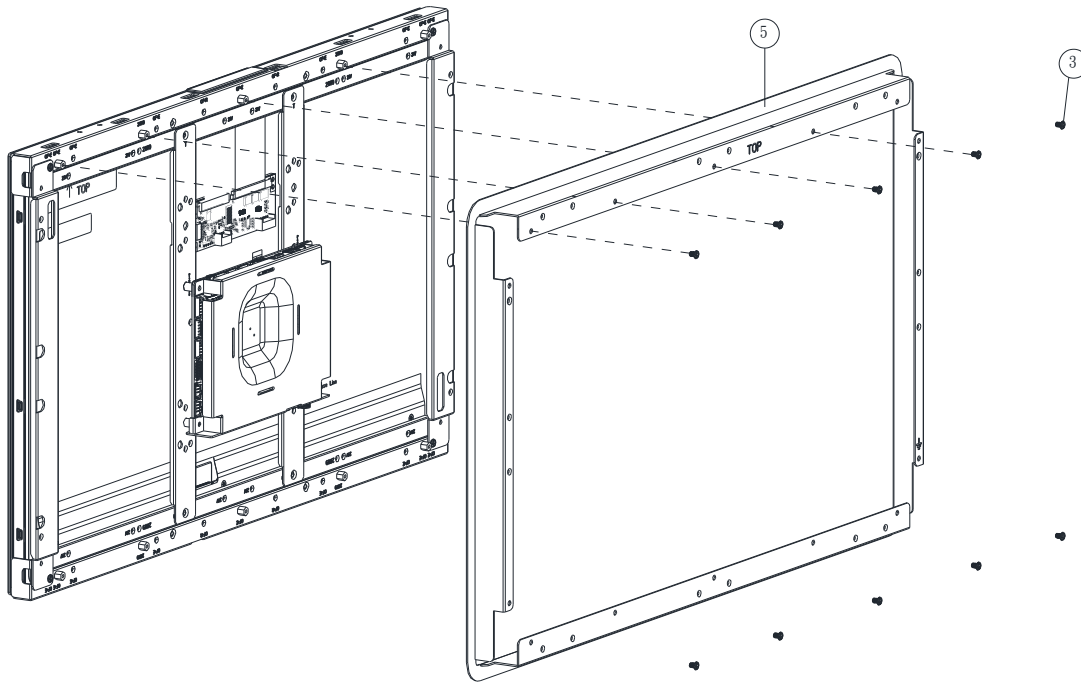

Step3. Insert and fasten 10 screws on each side of the monitor to secure Front bracket.

5	Front Bracket	1
3	Screw	10
Item	Part Name	Quantity

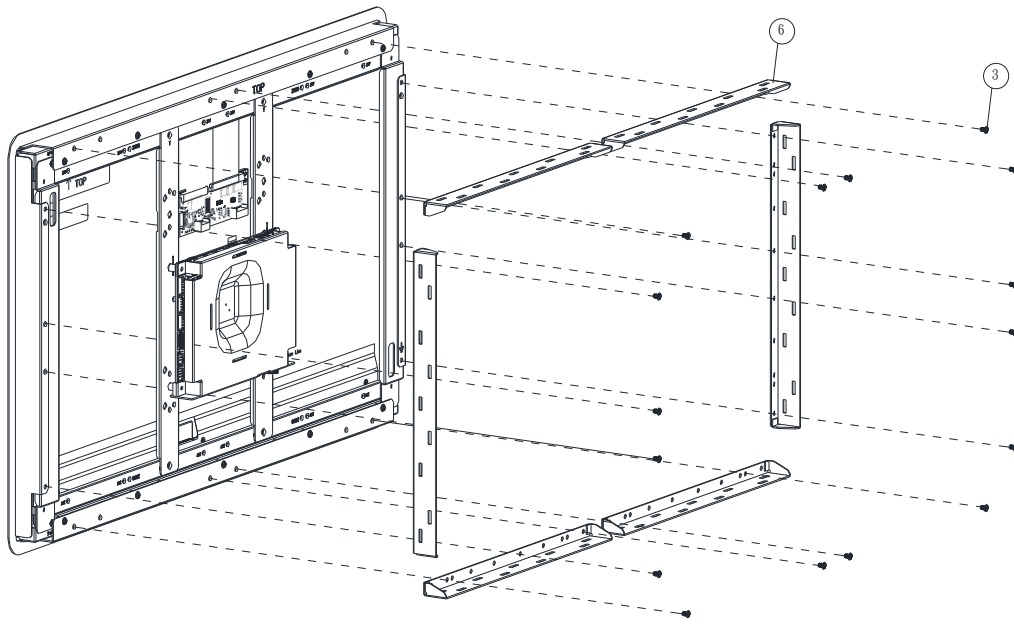

Step4. Insert and fasten 16 screws to secure Bracket.

3	Screw	16
6	Panel Mount Bracket	6
Item	Part Name	Quantity

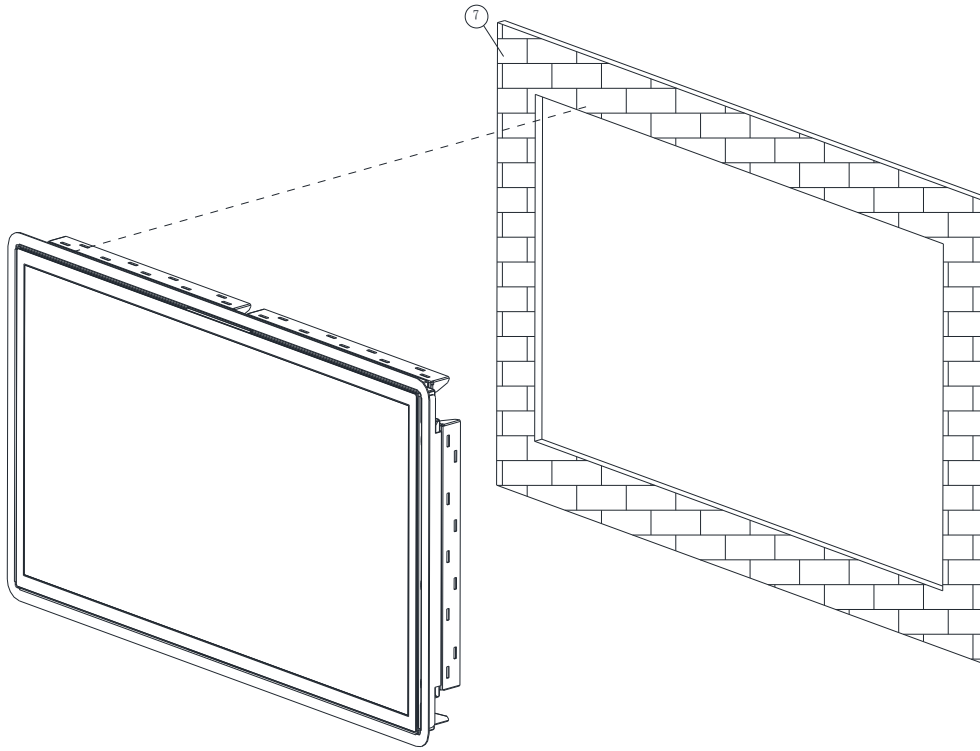

(Outside of the wall)

Step5. Insert OFT-21W03 into the wall.

7	Wall	1
Item	Part Name	Quantity

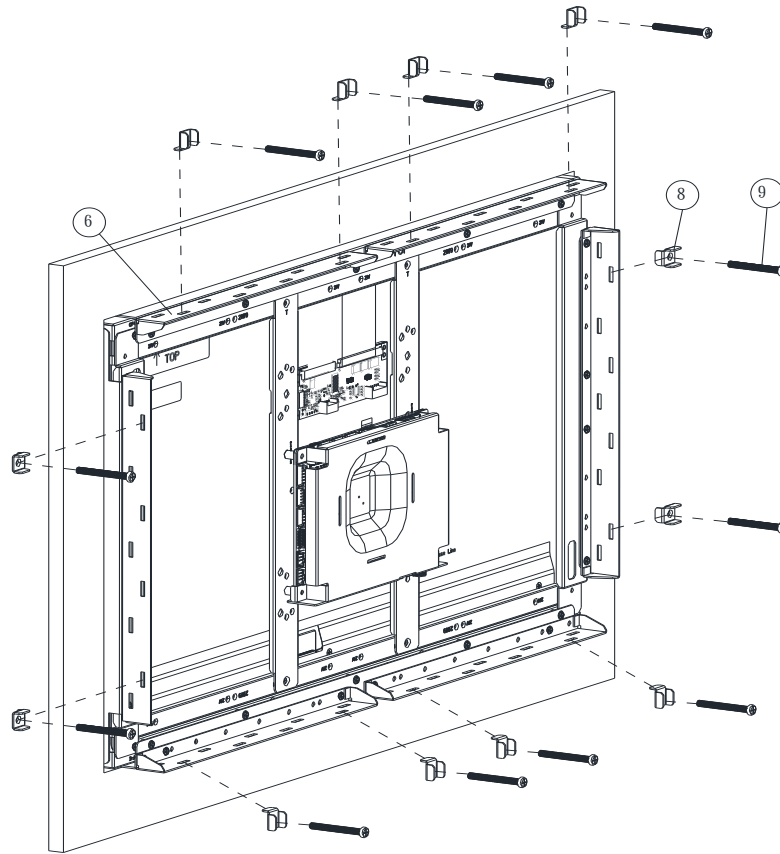

(Inside of the wall)

Step6. Fasten 12 screws to secure Panel mount brackets and insert it into Bracket.

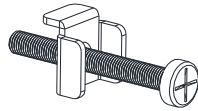

6-1

9	Panel mount Screw	12
8	Panel Mount Kit Bracket	12
6	Panel Mount Bracket	6
Item	Part Name	Quantity

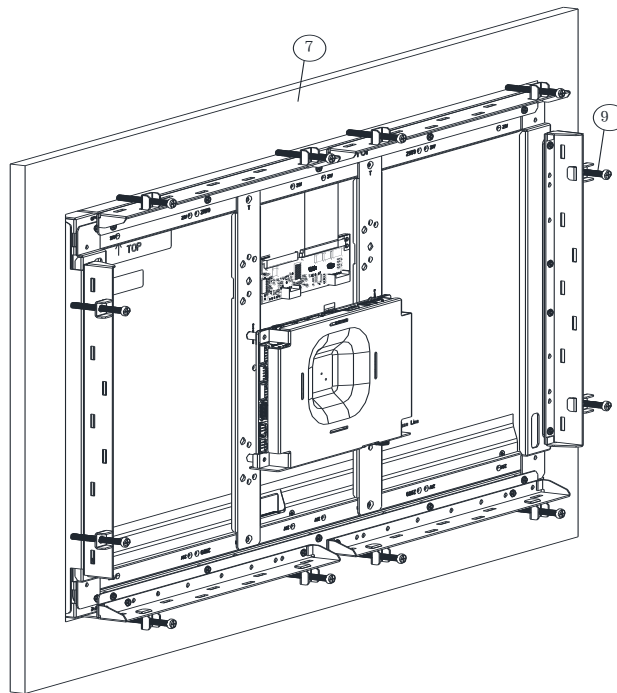

Step7. Insert and fasten 12 Panel mount screws to secure the module.

9	Panel mount Screw	12
7	Wall	1
Item	Part Name	Quantity

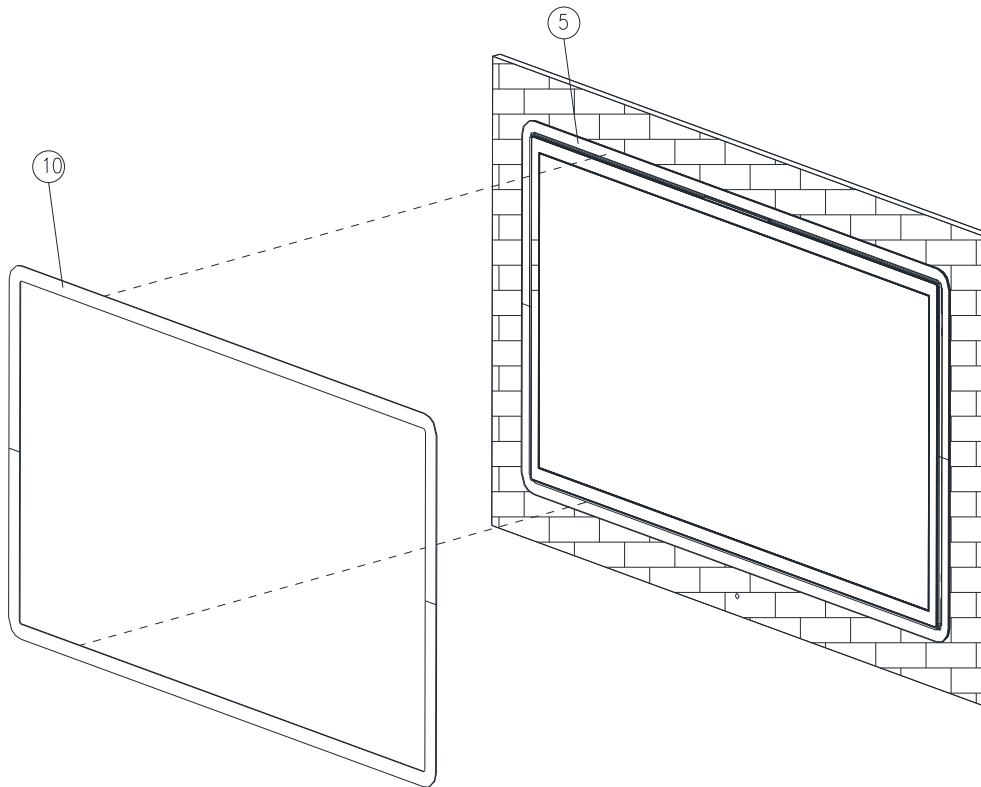

Step8. Paste 2 U Plates on the Front bracket.

10	U Plate	2
5	Front Bracket	1
Item	Part Name	Quantity

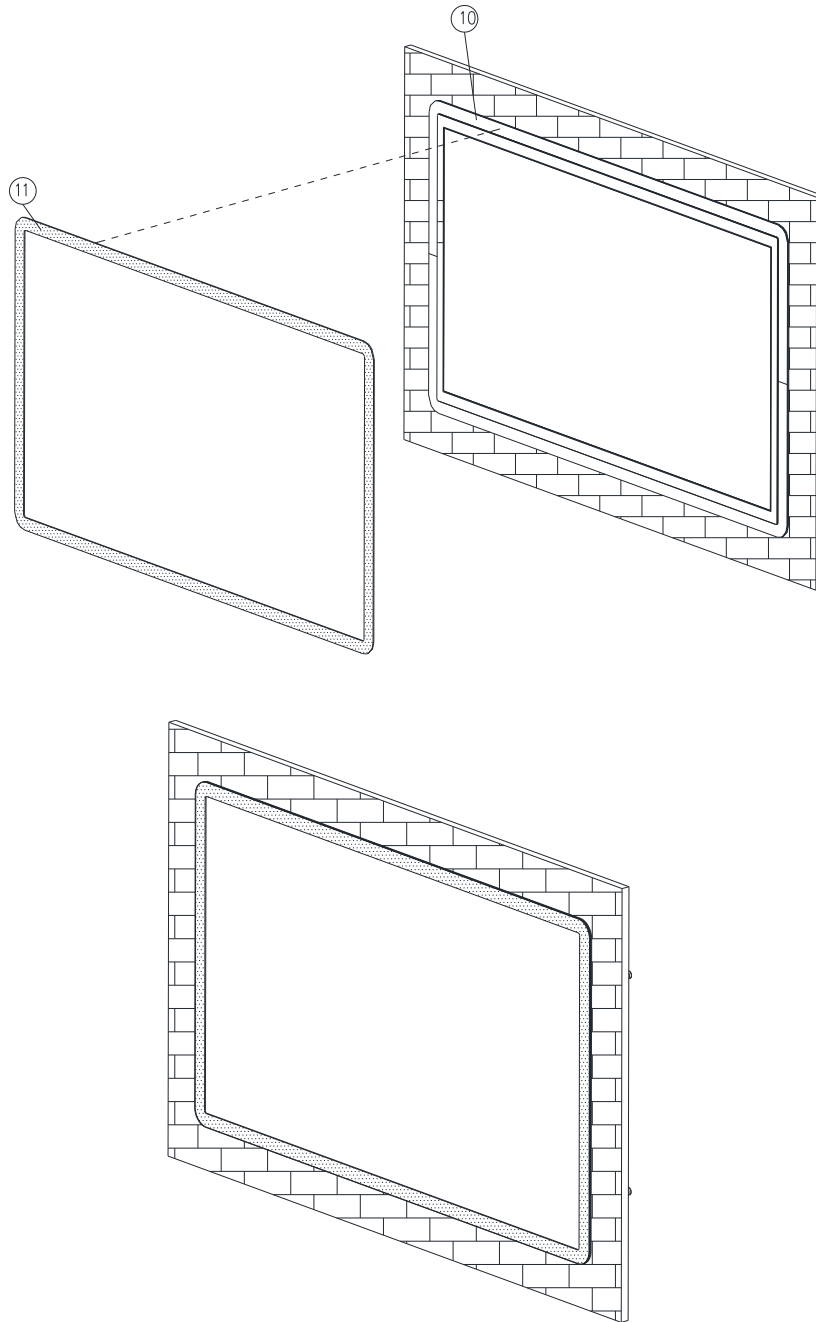

Step9. Paste the Decoration Plate on the U Plate to complete installation.

11	Decoration Plate	1
10	U Plate	2
Item	Part Name	Quantity

1.8 Wall Mounting Concept

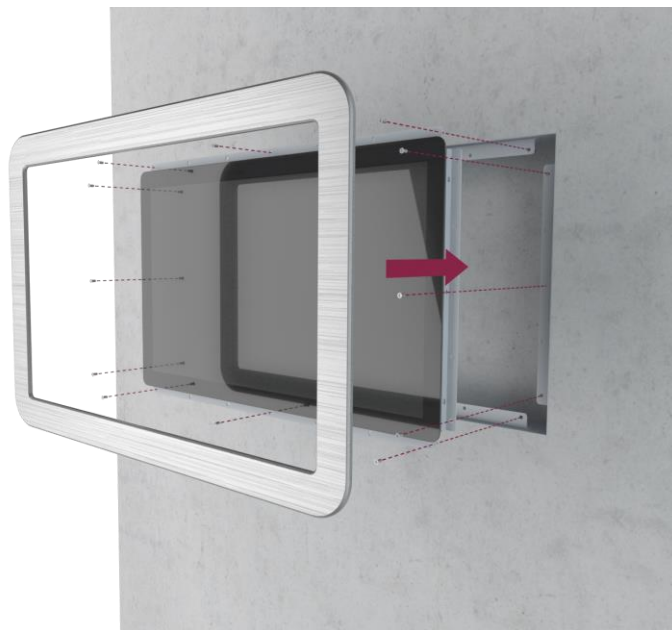
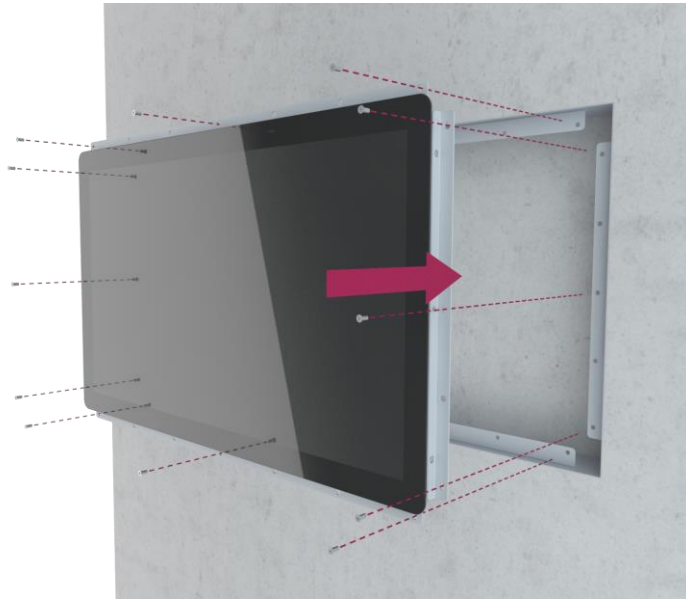

1.9 Wall Mounting

Size of the opening

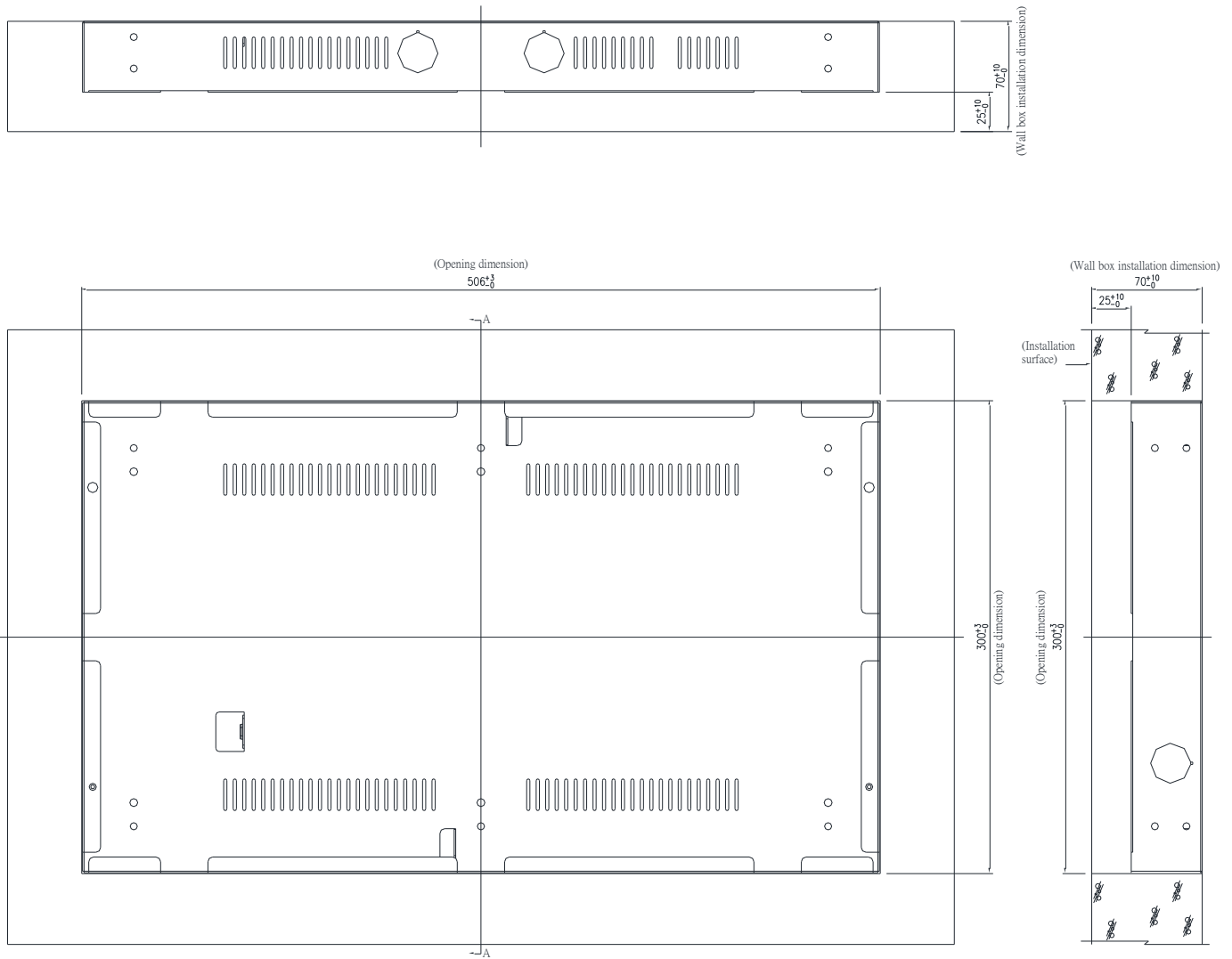

(Unit: mm)

OFT-21W03

Screw hole location

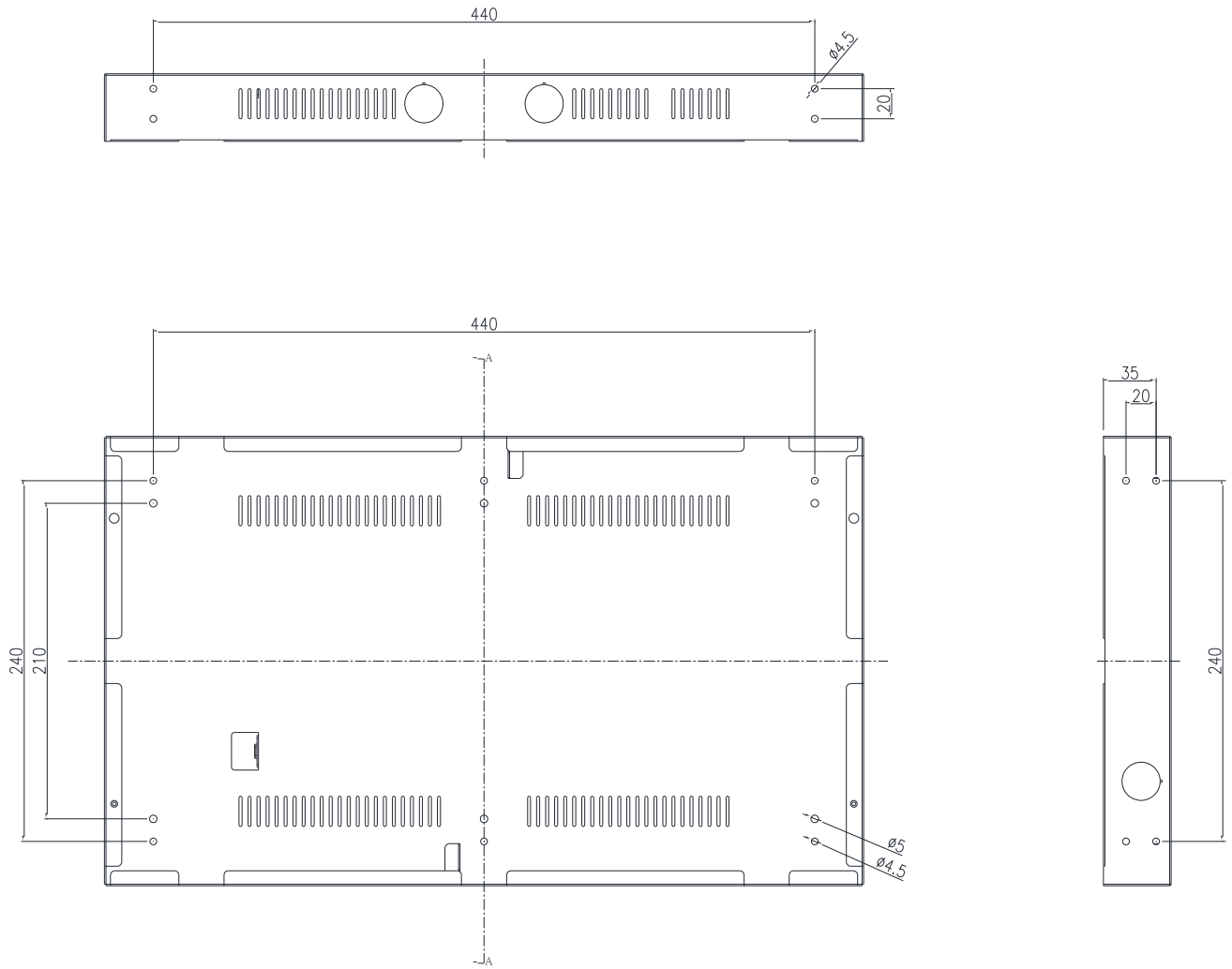

(Unit: mm)

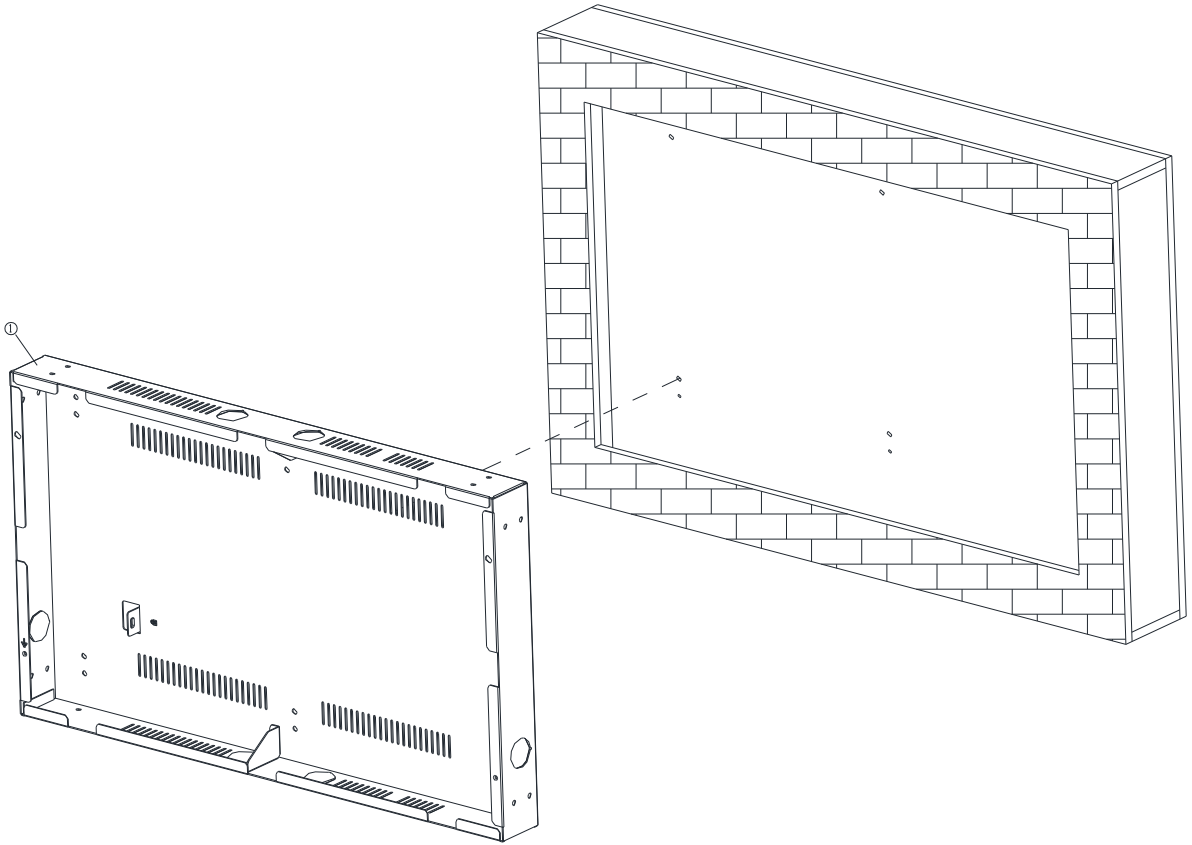

Step1. Fasten the screw on the wall.

1	Wall box	1
Item	Part Name	Quantity

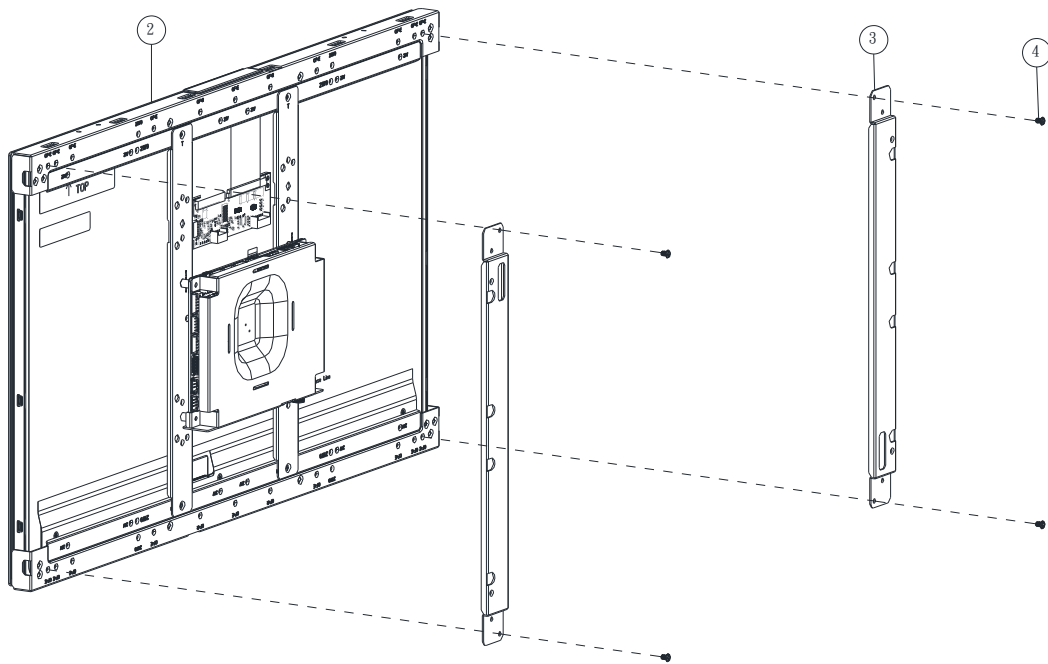

Step2. Insert and fasten 4 screws to secure Bracket R/L.

4	Screw	4
3	Bracket-RL	2
2	21_ASSY	1
Item	Part Name	Quantity

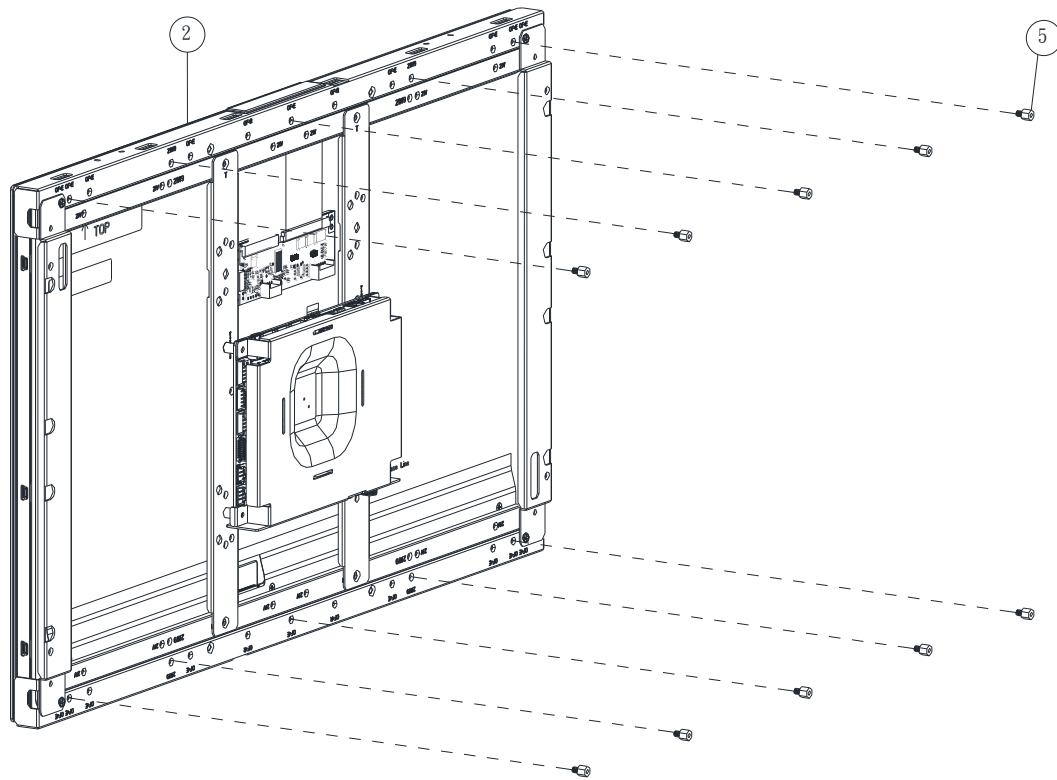

Step3. Insert and fasten 10 screws on each side of the monitor to secure brackets.

5	Hexagon Stud	10
2	21_ASSY	1
Item	Part Name	Quantity

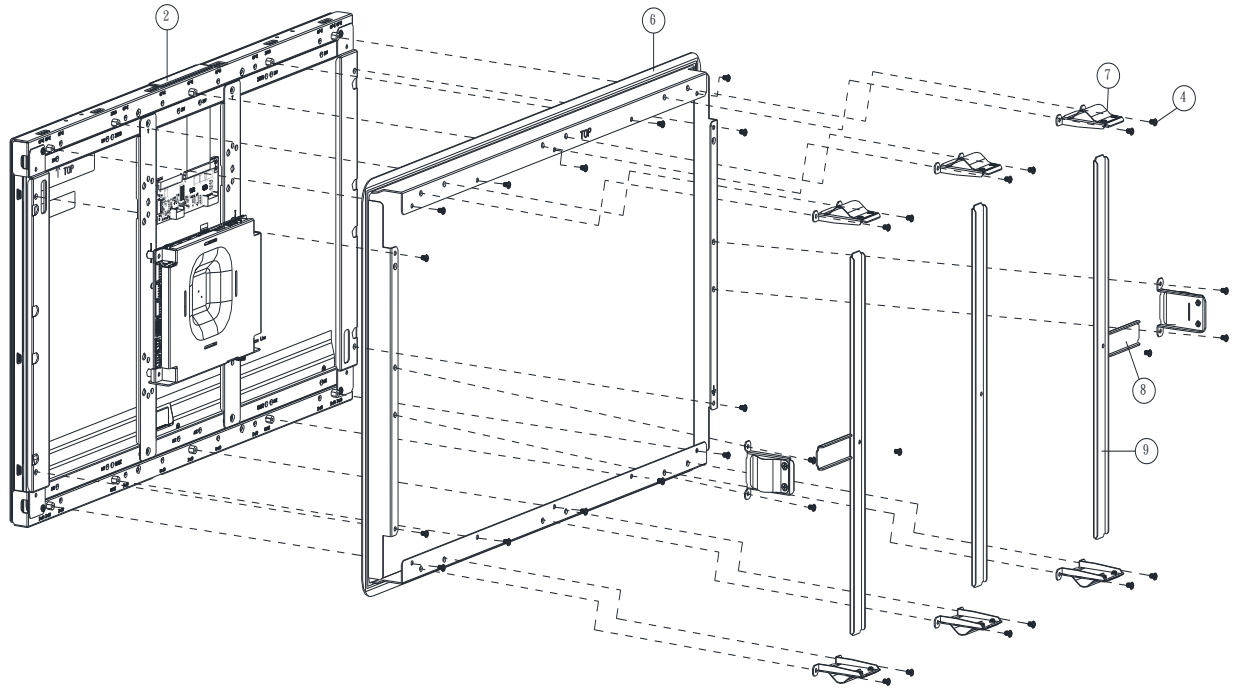

Step4-1. Insert and fasten 14 screws on each side of the monitor to secure Front bracket.

Step4-2. Fasten 6 screws on Front bracket of the monitor to secure Wall mount kit.

Step4-3. Fasten 2 screws on Support Bracket-V (2pcs) of the monitor to secure Support Bracket-H (2pcs).

Step4-4. Insert the Support Bracket-H into the rectangular hole of the locked Wall mount kit.

Insert the Support Bracket-V into the rectangular hole of the Unlocked Wall mount kit and fasten 2 screws to secure Front bracket. (This step is done 3 times in total)

Step4-5. Insert the Support Bracket-H into the rectangular hole of the Wall mount kit and fasten 2 screws to secure Front bracket. (This step is done 2 times in total)

9	Support Bracket-V	3
8	Support Bracket-H	2
7	Wall mount kit	8
4	Screw	31
6	Front bracket	1
Item	Part Name	Quantity

Quick Reference Guide

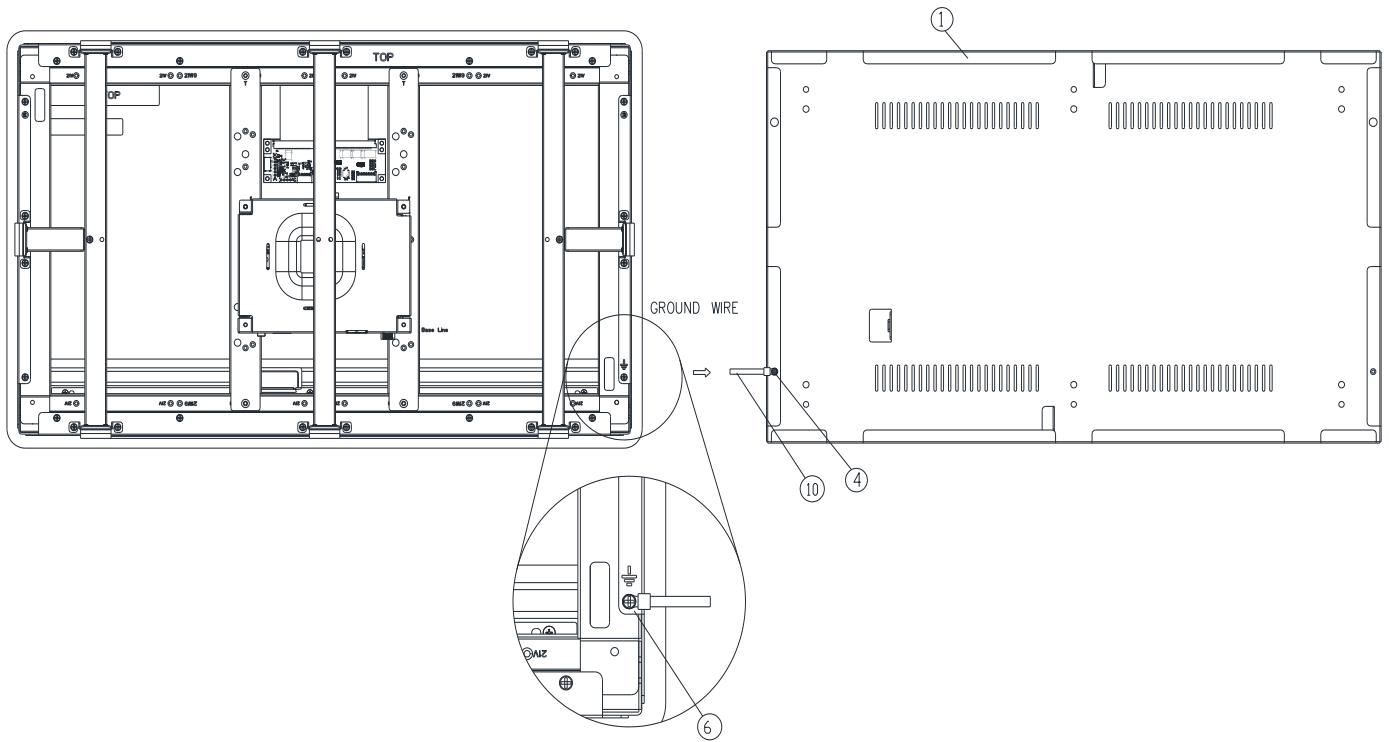

Step5. Insert and fasten 2 screws on Front bracket and Wall box of the monitor to secure Ground wire.

10	Ground wire	1
4	Screw	2
6	Front bracket	1
1	Wall box	1
Item	Part Name	Quantity

OFT-21W03

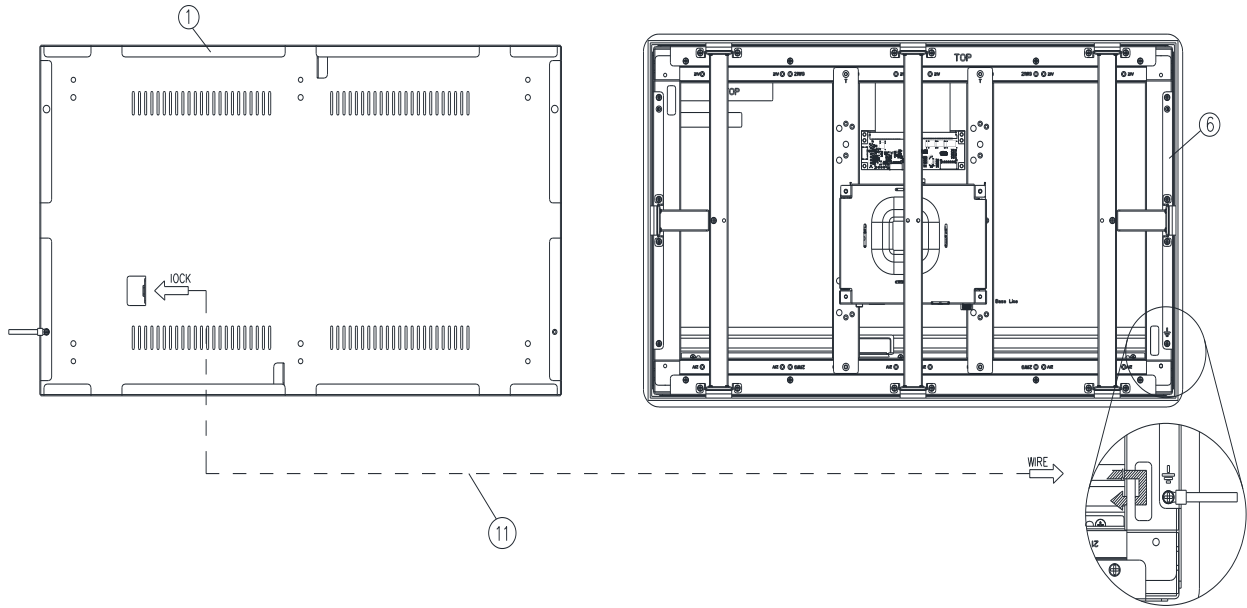

Step6. Wrap the Kensington lock (option) around the hole in the front bracket and attach the lock to the keyhole in the Wall box.

11	Kensington lock	1
6	Front bracket	1
1	Wall box	1
Item	Part Name	Quantity

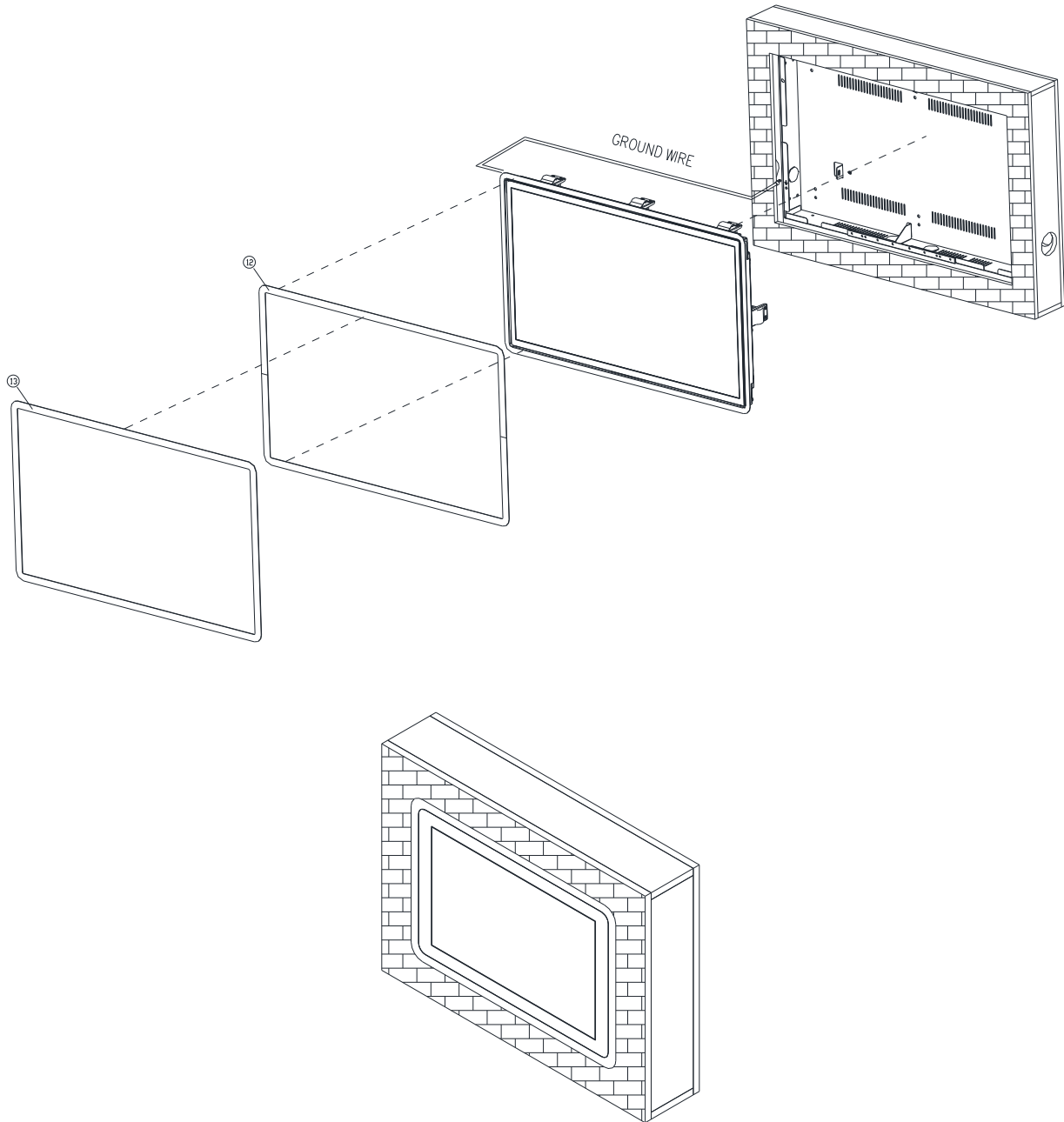

Step7-1. Insert the Ground wire and Kensington lock in the Wall box and Insert OFT-21W03 into the wall.

Step7-2. Paste the U Bracket (2pcs) on the Front bracket.

Step7-3. Paste the Decoration Plate on the U Bracket to complete installation.

12	U Bracket	2
11	PC bezel	1
Item	Part Name	Quantity

2. Hardware Configuration

For advanced information, please refer to:

- 1- Motherboard included in this manual.



Note: If you need more information, please visit our website:

<http://www.avalue.com.tw>

2.2 Motherboard Overviews

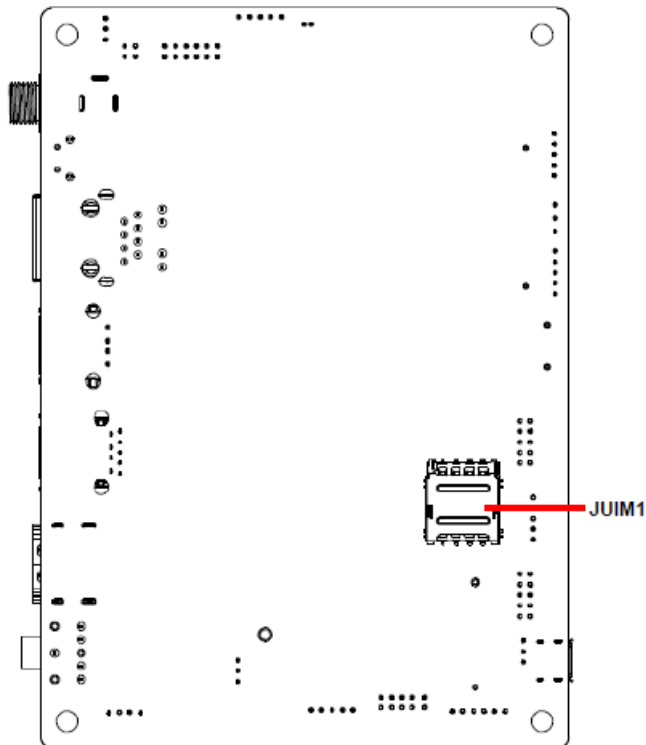
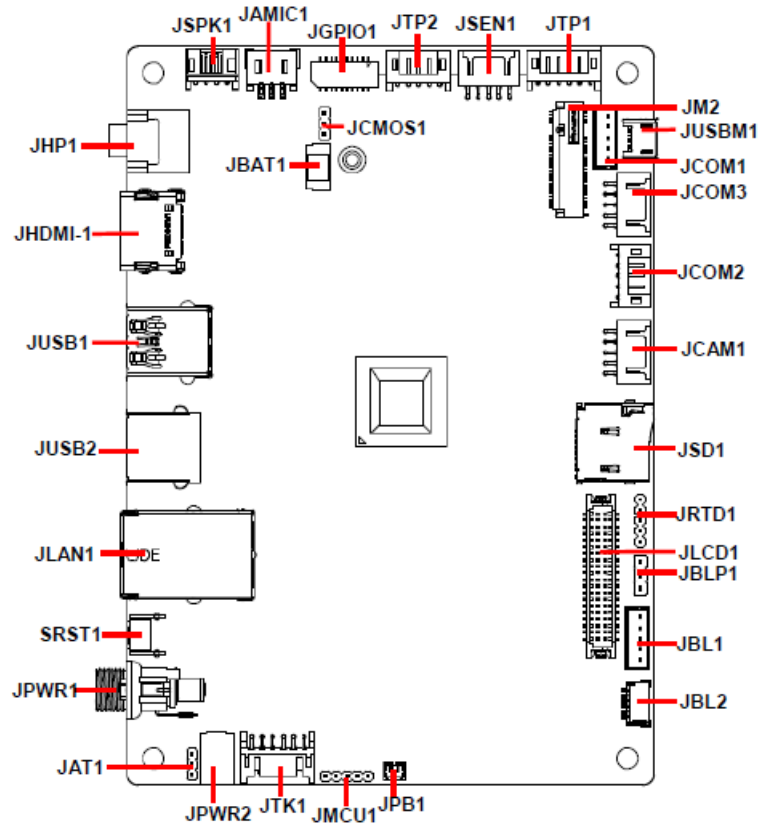

2.3 Motherboard Connector list

Jumpers

Label	Function	Note
JCMOS1	Clear CMOS	3 x 1 header, pitch 2.00 mm
JBLP1	Backlight power select	3 x 1 header, pitch 2.54 mm
JAT1	AT/ATX Input power select	3 x 1 header, pitch 2.00 mm

Connectors

Label	Function	Note
JHP1	Audio line-out connector	
JHDMI-1	HDMI connector	
JUSB1	USB 3.0 connector	
JUSB2	USB 2.0 connector	
JLAN1	RJ-45 Ethernet connector	
SRST1	Reset button	
JPWR1	Power connector	
JPWR2	DC Power-in connector	2 x 2 wafer, pitch 2.00 mm
JTK1	Touch Key Button	6 x 2 wafer, pitch 2.00 mm
JMCU1	MCU connector	5 x 1 header, pitch 2.00 mm
JPB1	Power button	2 x 1 wafer, pitch 1.25 mm
JSPK1	Speaker interface	4 x 1 wafer, pitch 2.00 mm
JAMIC1	A-MIC connector	3 x 1 wafer, pitch 2.00 mm
JGPIO1	General purpose I/O connector	10 x 2 wafer, pitch 1.00 mm
JTP1	I2C Touch Panel connector	6 x 1 wafer, pitch 2.00 mm
JTP2	USB Touch connector	5 x 1 wafer, pitch 2.00 mm
JSEN1	I2C Sensor	5 x 2 wafer, pitch 2.00 mm
JM2	M.2 B-Key socket	
JUSBM1	Micro USB connector	
JCOM1	Console Debug connector	5 x 1 wafer, pitch 2.00 mm
JCOM2	RS-232 connector	5 x 1 wafer, pitch 2.00 mm
JCOM3	RS-232 & RS-485 connector	5 x 2 wafer, pitch 2.00 mm
JCAM1	USB Camera & DMIC connector	5 x 2 wafer, pitch 2.00 mm
JSD1	Micro SD card slot	

JRTD1	RTD connector	5 x 1 header, pitch 2.00 mm
JLCD1	LVDS/eDP connector	20 x 2 wafer, pitch 1.25 mm
JBL1	Backlight connector 1	5 x 1 wafer, pitch 2.00 mm
JBL2	Backlight connector 2	6 x 1 wafer, pitch 1.00 mm
JBAT1	RTC battery connector	2 x 1 wafer, pitch 1.25 mm
JUIM1	Micro SIM Card socket	

***RTC Battery**

Warning: Risk of Explosion if Battery is replaced by an Incorrect Type. Dispose of Used Batteries According to the Instructions."

Attention: Risque d'explosion si la batterie est remplacée par un type incorrect. Jetez les piles usagées selon les instructions.

2.4 Motherboard Jumpers & Connectors settings

2.4.1 Clear CMOS (JCMOS1)

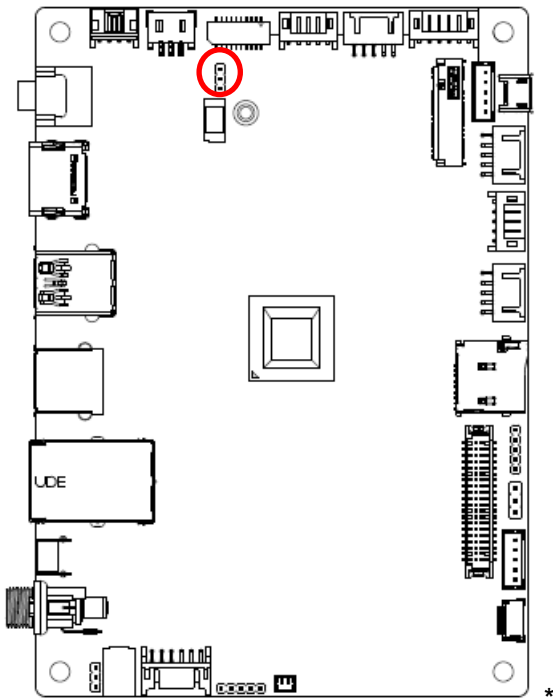

Protect*

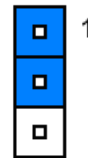

Clear CMOS

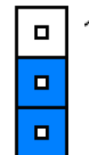

Default

2.4.2 Backlight power select (JBLP1)

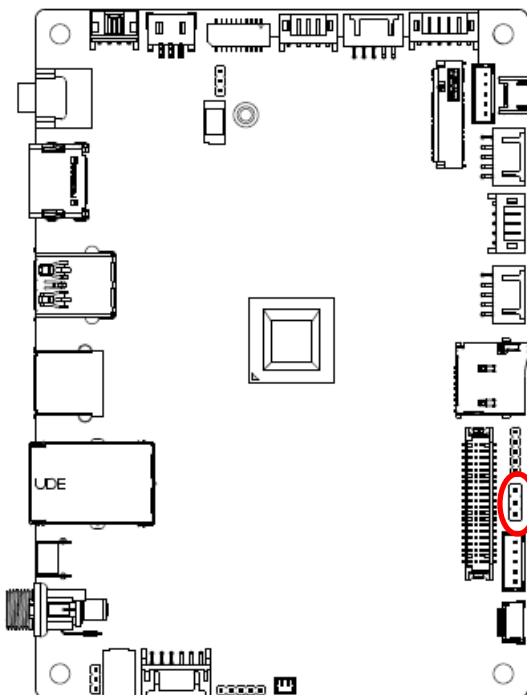

3.3V*

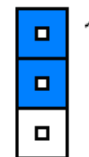

5V

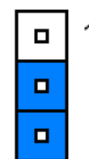

* Default

2.4.3 AT/ATX Input power select (JAT1)

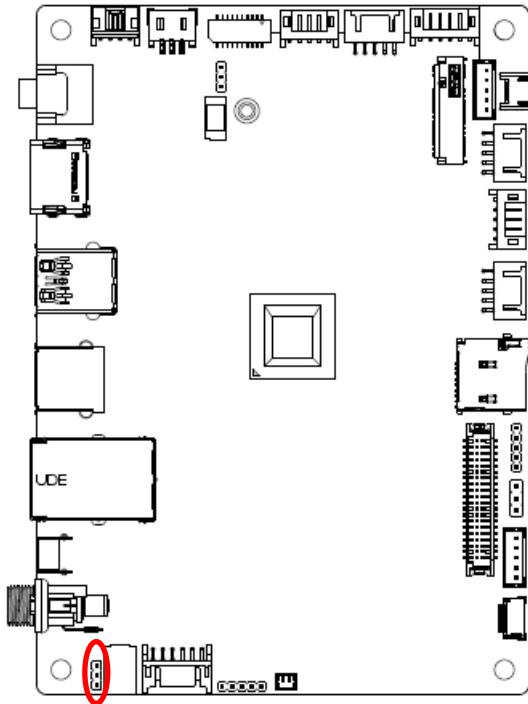

AT*

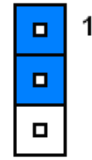

ATX

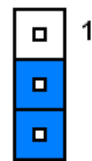

* Default

2.4.4 DC Power-in connector (JPWR2)

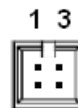
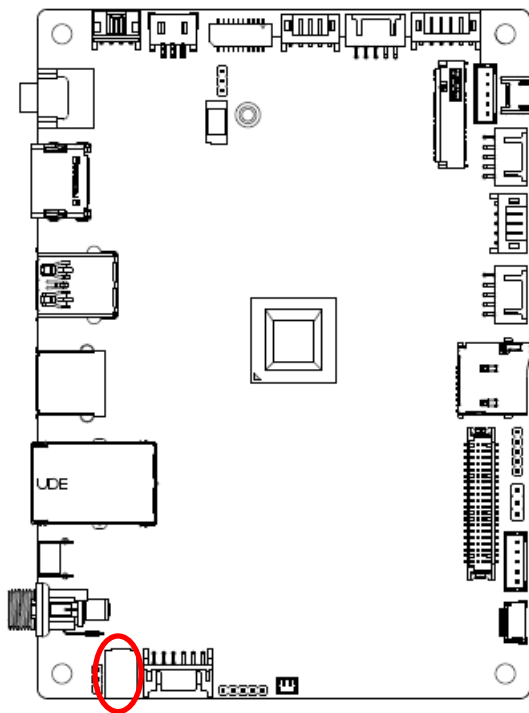

Signal	PIN	PIN	Signal
DC-IN	1	3	DC-IN
GND	2	4	GND

2.4.5 Touch Key Button (JTK1)

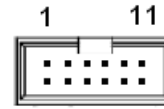
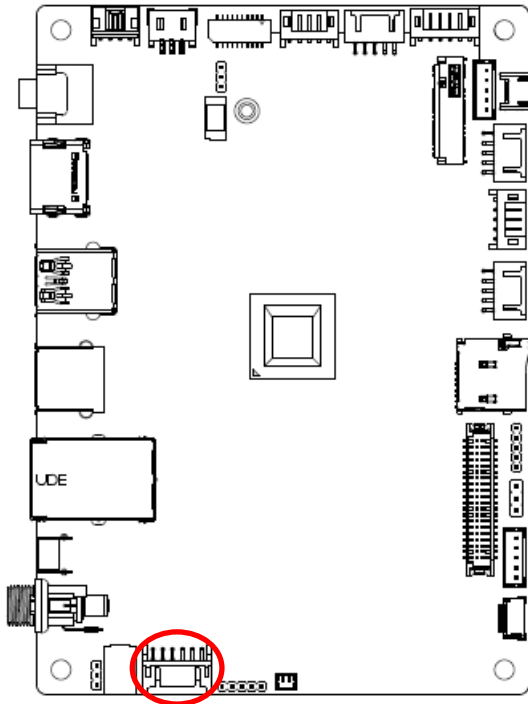

Signal	PIN	PIN	Signal
+5V	1	2	GND
KEY_RST-BTN	3	4	KEY_BU1
KEY_VOL-UP	5	6	KEY_VOL-DN
KEY_PWR-BTN	7	8	KEY_BR-UP
KEY_BR-DN	9	10	KEY_BU7
LED_GRN	11	12	LED_ORG

2.4.6 MCU connector (JMCU1)

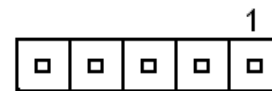
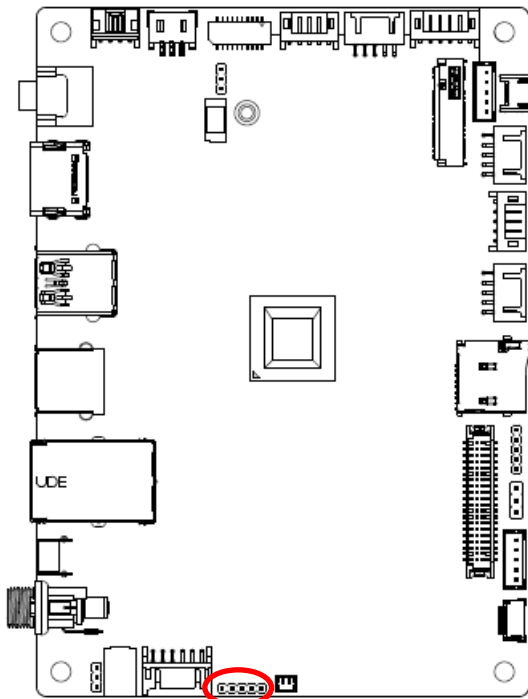

Signal	PIN
+5V	1
PIC_MCLR	2
PIC_ICSPCLK	3
PIC_ICSPDAT	4
GND	5

2.4.7 Power button (JPB1)

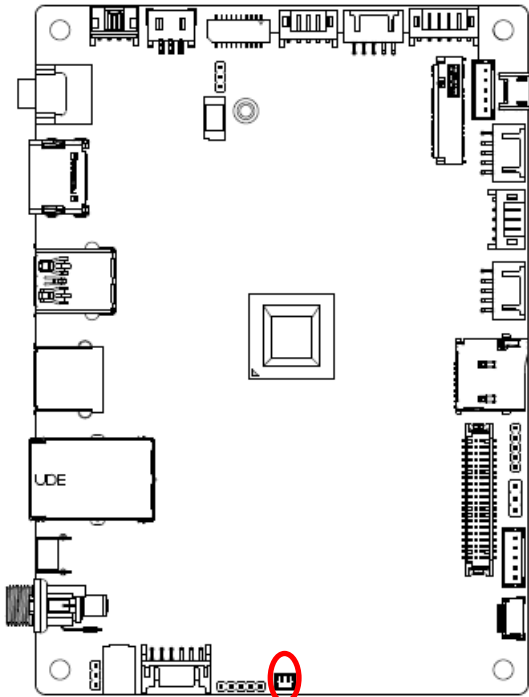

Signal	PIN
+5V	1
KEY_PWR-BTN	2

2.4.8 Speaker interface (JSPK1)

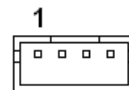
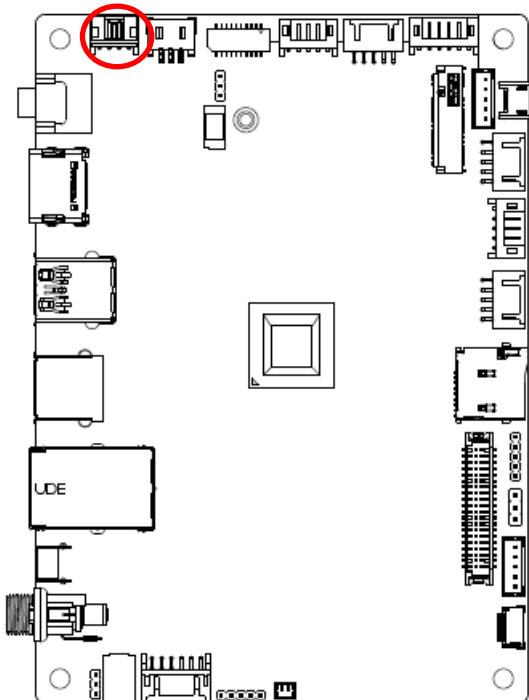

Signal	PIN
SPK_L+	1
SPK_L-	2
SPK_R+	3
SPK_R-	4

2.4.9 A-MIC connector (JAMIC1)

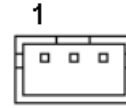
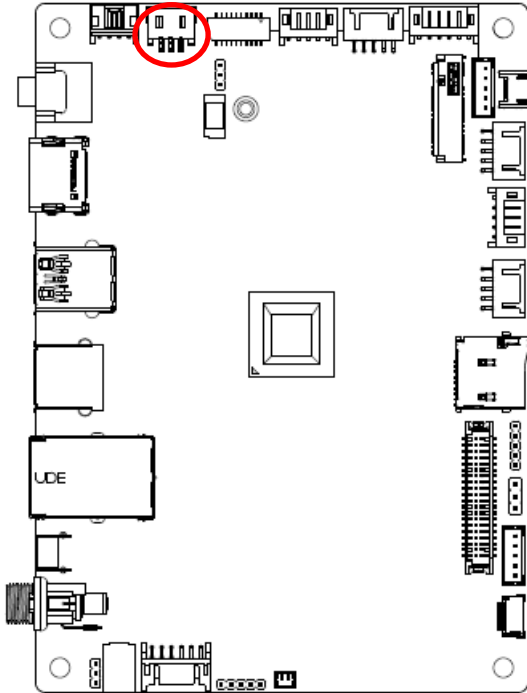

Signal	PIN
MIC_JD	1
MIC_IN	2
GND	3

2.4.10 General purpose I/O connector (JGPIO1)

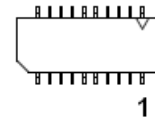
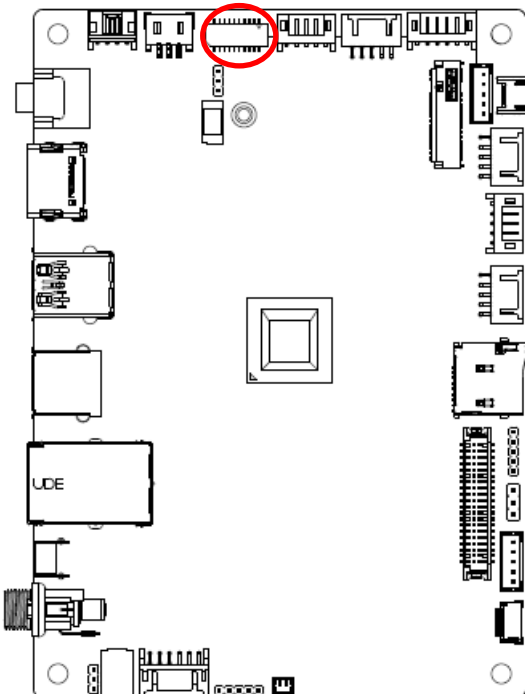

Signal	PIN	PIN	Signal
DIO_GP00	1	2	DIO_GP10
DIO_GP01	3	4	DIO_GP11
DIO_GP02	5	6	DIO_GP12
DIO_GP03	7	8	DIO_GP13
DIO_GP04	9	10	DIO_GP14
DIO_GP05	11	12	DIO_GP15
DIO_GP06	13	14	DIO_GP16
DIO_GP07	15	16	DIO_GP17
DIO_SDA_3.3	17	18	DIO_SCL_3.3
+5V	19	20	GND

2.4.11 I2C Touch Panel connector (JTP1)

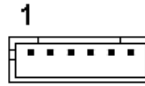
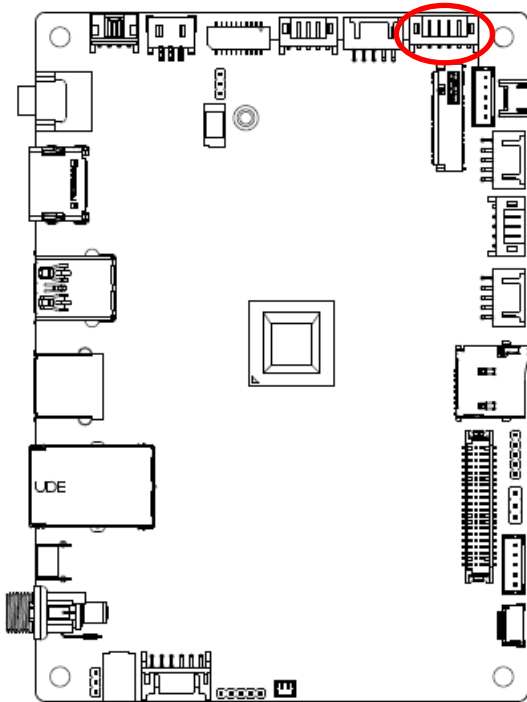

Signal	PIN
+3.3V	1
GND	2
TP_INT#	3
TP_SCL	4
TP_SDA	5
TP_RST#	6

2.4.12 USB Touch connector (JTP2)

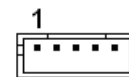
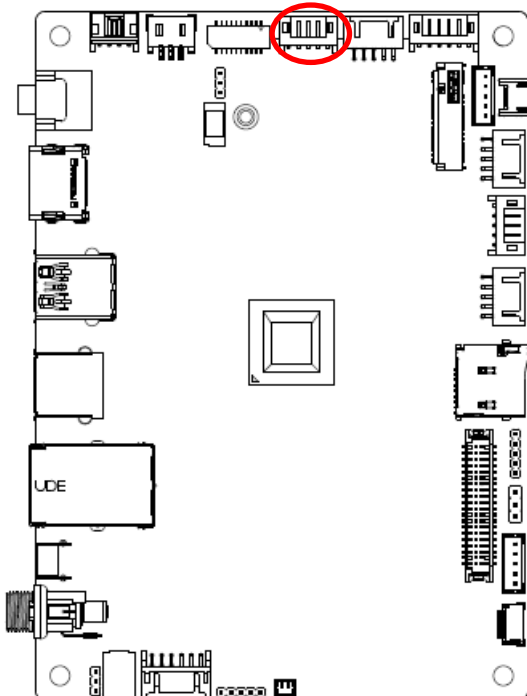

Signal	PIN
+5V	1
USB_JTP2_N	2
USB_JTP2_P	3
GND	4
GND	5

2.4.13 I2C Sensor (JSEN1)

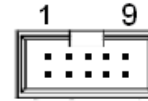
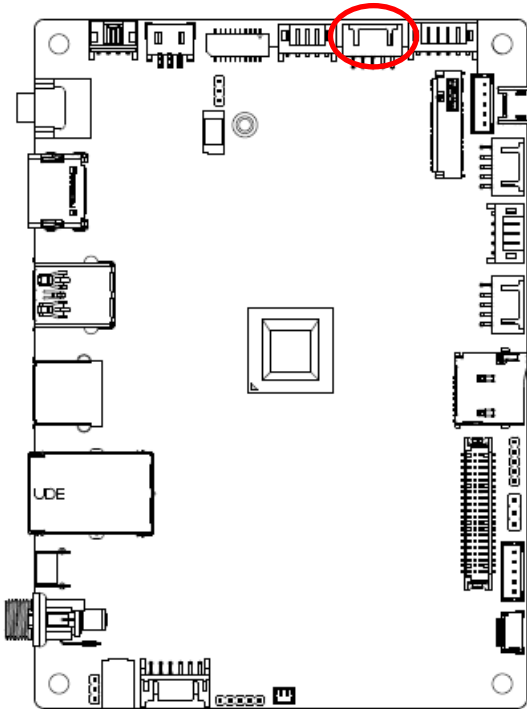

Signal	PIN	PIN	Signal
+3.3V	1	2	+3.3V
SEN1_SCL	3	4	SEN2_SCL
SEN1_SDA	5	6	SEN2_SDA
SEN1_IRQP#	7	8	SEN2_IRQP#
GND	9	10	GND

2.4.14 Console Debug connector (JCOM1)

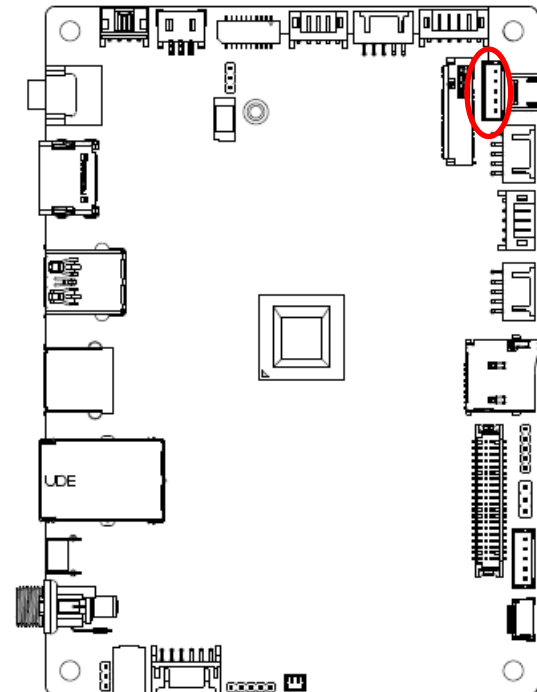

Signal	PIN
COM1_TX_232	1
COM1_RX_232	2
GND	3
COM1_AX7_P4_RX_232	4
COM1_AX7_P4_TX_232	5

2.4.15 RS-232 connector (JCOM2)

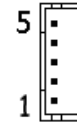
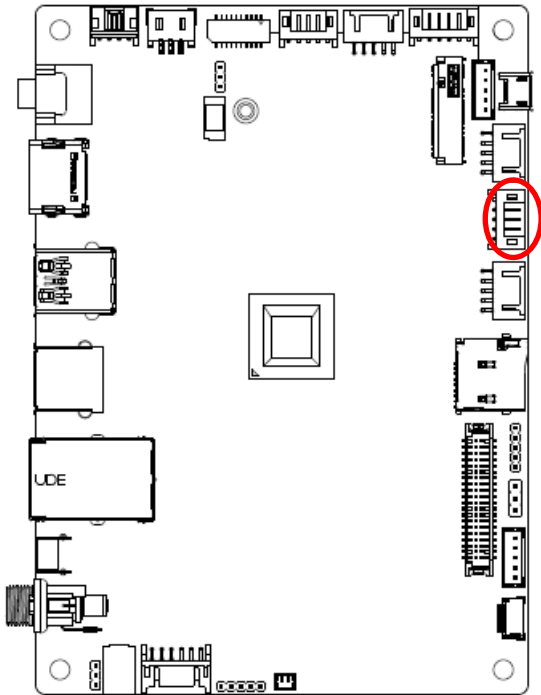

Signal	PIN
GND	5
COM2_CTS_232	4
COM2_RTS_232	3
COM2_RX_232	2
COM2_TX_232	1

2.4.16 RS-232 & RS-485 connector (JCOM3)

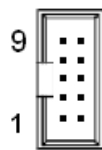
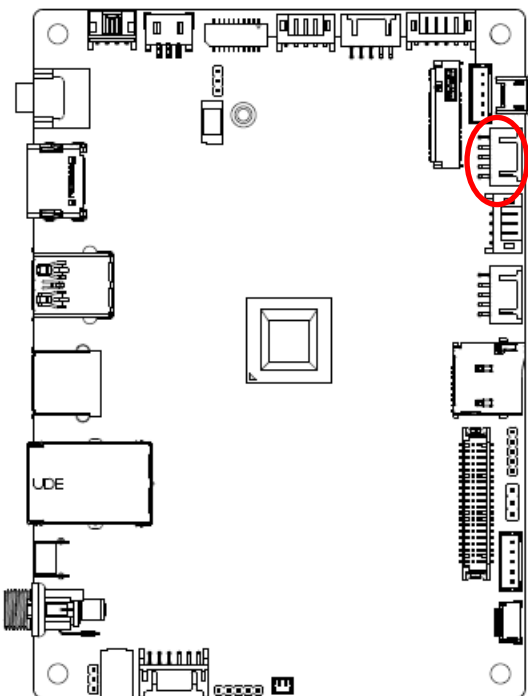

RS232

Signal	PIN	PIN	Signal
GND	9	10	GND
232_CTS_2	7	8	NC
232_RTS_2	5	6	NC
232_RXD_2	3	4	NC
232_TXD_2	1	2	+5V

RS485

Signal	PIN	PIN	Signal
GND	9	10	GND
NC	7	8	Data+
NC	5	6	Data-
NC	3	4	NC
NC	1	2	+5V

2.4.17 USB Camera & DMIC connector (JCAM1)

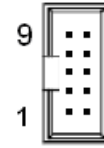
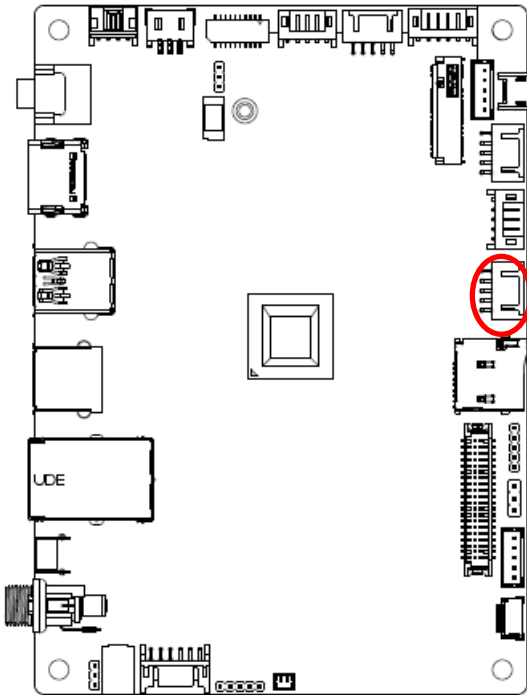

Signal	PIN	PIN	Signal
GND	9	10	GND
GND	7	8	GND
DMIC_DATA	5	6	USB_JCAM1_P
DMIC_CLK	3	4	USB_JCAM1_N
+1.8V	1	2	+5V

2.4.18 RTD connector (JRTD1)

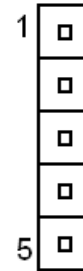
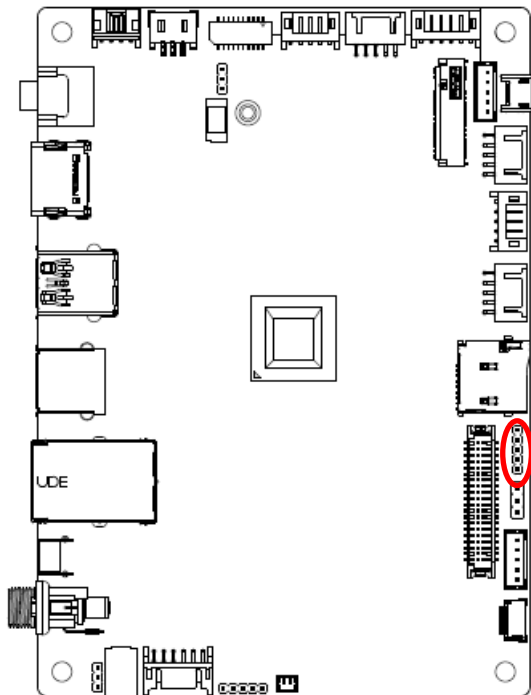

Signal	PIN
+3.3V	1
RTD-EE_WP	2
RTD-EE_SCL	3
RTD-EE_SDA	4
GND	5

2.4.19 LVDS/eDP connector (JLCD1)

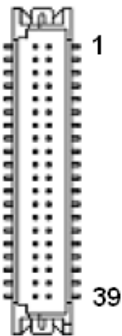
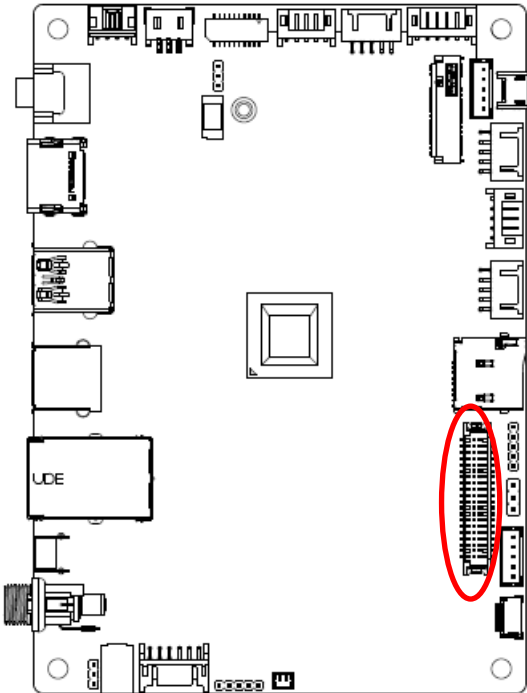

Signal	PIN	PIN	Signal
+5V	2	1	+3.3V
+5V	4	3	+3.3V
NC	6	5	EDP-HPD
GND	8	7	GND
LVDS-TX00+_EDP-TX0P	10	9	LVDS-TX01+_EDP-TX1P
LVDS-TX00-_EDP-TX0N	12	11	LVDS-TX01-_EDP-TX1N
GND	14	13	GND
LVDS-TX02+_EDP-AUXP	16	15	LVDS_TX03+
LVDS-TX02-_EDP-AUXN	18	17	LVDS_TX03-
GND	20	19	GND
LVDS_TXE0+	22	21	LVDS_TXE1+
LVDS_TXE0-	24	23	LVDS_TXE1-
GND	26	25	GND
LVDS_TXE2+	28	27	LVDS_TXE3+
LVDS_TXE2-	30	29	LVDS_TXE3-
GND	32	31	GND
LVDS_TXOC+	34	33	LVDS_TXEC+
LVDS_TXOC-	36	35	LVDS_TXEC-
GND	38	37	GND
+12V	40	39	+12V

2.4.20 Backlight connector 1 (JBL1)

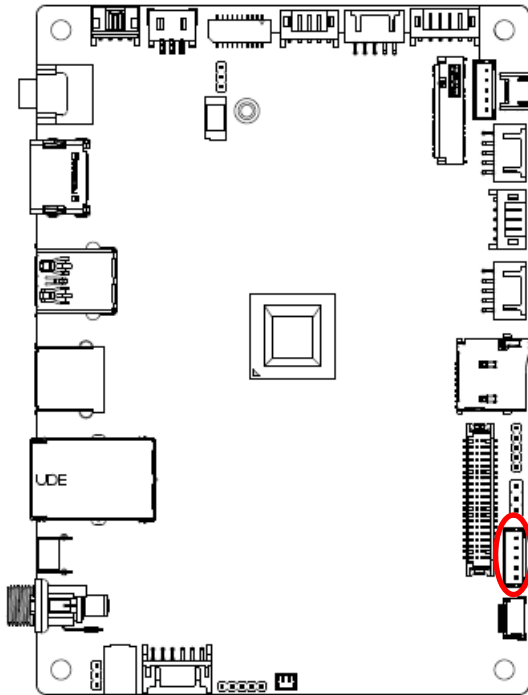

Signal	PIN
+12V	1
GND	2
BL_EN	3
BL_PWM	4
+5V	5

2.4.21 Backlight connector 2 (JBL2)

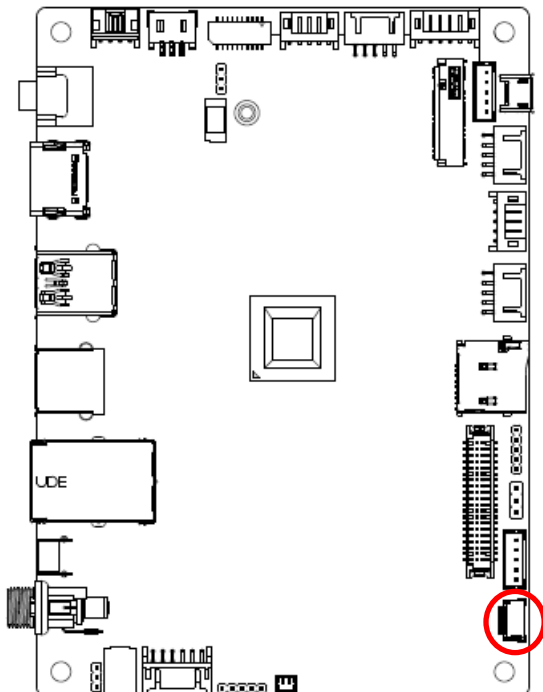

Signal	PIN
BKL_LED4	6
BKL_LED3	5
+38V	4
+38V	3
BKL_LED2	2
BKL_LED1	1

2.4.22 RTC battery connector (JBAT1)

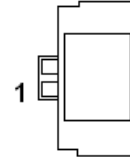
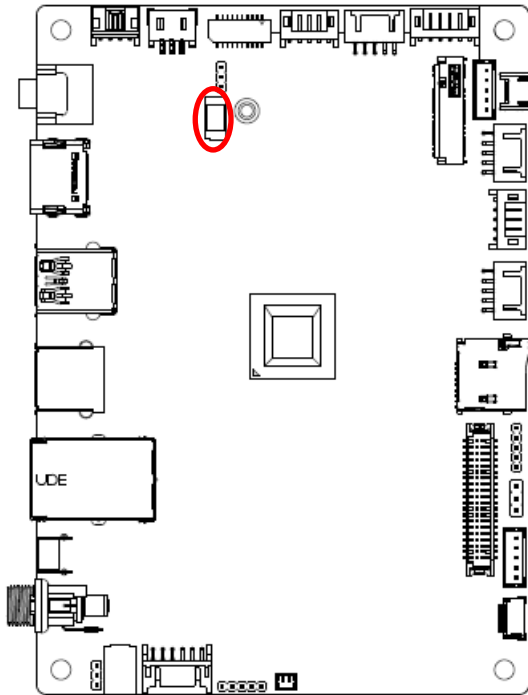

Signal	PIN
GND	2
+3V	1

