

M101EK

10.1" Windows Rugged Tablet PC with Intel® Celeron® N6211



KEY FEATURES

- Intel® Elkhart Lake Celeron® N6211 Processor
- 10.1" 1920 x 1200 IPS LED Panel with direct optical bonding
- IP65 water and dust proof with MIL-STD-810H rugged housing
- Low power consumption with fanless design
- Removable battery with hot-swap function for all day productivity
- Sunlight readable with antiglare solution
- USB Type-C port supports power delivery 20V In
- Integrated 4G/5G Wireless WWAN (Optional)



SPECIFICATIONS

Display	
Resolution	1920x1200
Contrast Ratio	800:1
View Angles	85,85,85,85
Type	Projected Capacitive Multi Touch
Touch Mode	Support Hand / Gloves and Rain Mode
Size	10.1 inches
Panel Brightness	800 nits
Bonding	Optical Bonding for Sunlight Viewability
Viewability	Anti-Glare touch treatment
System Specification	
Processor	Intel Celeron N6210 1.2GHz (up to 2.6GHz) Intel Pentium N6415 1.2GHz (up to 3GHz) (Optional)
Storage	128GB SSD Additional storage available with micro SDXC card slot 256GB SSD (Optional) 512GB SSD (Optional)
Memory	4GB LPDDR4 8GB LPDDR4 (Optional)
Operating System	Windows 10 IoT Enterprise LTSC (64 bit) Windows 11 IoT Enterprise SAC (64-bit) (Optional)
Security	Trusted Platform Module (TPM) 2.0 Kensington Lock
BT	Support
WLAN	Support
GNSS	GPS, GLONASS, Galileo, BeiDou
WWAN	4G (Optional) 5G (Optional)
Sensors	Light sensor/ G-sensor / Gyro
RFID	HF RFID 13.56 MHz reader (Optional) add-on UHF RFID Reader (Optional)
Smart Card Reader	Add-on Smart Card Reader (Optional)
Camera	
Front Camera	2MP Front Camera
Rear Camera	8MP Rear Camera with auto-focus and LED light
Mechanical	
Dimension	271.9 x 197.3 x 19.5 mm
Weight	1.2 kg (2.65 lbs) with standard battery, 1.4 kg (3.1 lbs) with optional high capacity battery
Enclosure	Fanless design
IO Ports	
USB Port	1 x USB 3.0 (Type A), 1 x USB 3.0 (Type-C) support Power Delivery 20V In)
SD Card Slot	1 x Micro SD Card slot (Support SDXC)
SIM Card Slot	1 x SIM card slot
Video	1 x Micro HDMI Output (Optional)
Audio	1 x Audio combo 3.5mm audio combo jack (Mic in)
Expansion Port	1 x Expansion connector (Optional)

or Line Out)
Dual Digital Mic With Noise Cancellation
Dual Speaker

Indicator 4x LED Indicator for Power, Battery, HDD, RF status

Docking Connector 1 x 19-pin docking connector

Environment

Operating Humidity	10% to 90% RH, non-condensing	Operating Temperature	-20°C to 60°C (AC mode), -10°C to 50°C (Battery mode)
Storage Temperature	-30°C to 70°C (-22°F to 158°F)	Shock	MIL-STD-810H Method 516.8 Procedure I
Vibration	MIL-STD-810H Method 514.8 Procedure I	IP rating	IP65
Drop	MIL-STD-810H Method 516.8, 4 ft		

Certification

Certification CE, FCC

Control

Button 1 x Power, 1 x Home, 2 x Volume, 2 x Programmable Function Keys

Power

Battery	Hot-swappable 7.7V, typ. 5900 mAh Li-Polymer Battery (2S1P) 7.4V, typ. 10280 mAh Li-Polymer Battery (2S2P, optional)	Battery Operating Time	Standard. Battery: 9 hours High Capacity Battery: 16 hours
Power Rating	19V DC	Adapter	100-240V, 50-60Hz / 19V DC

Security Function

SOTI MobiControl	SOTI MobiControl Compliance	Kensington Lock	Kensington Lock
-------------------------	-----------------------------	------------------------	-----------------

Accessory

Accessory	Adapter and Power Cord Capacitive Stylus Standard Battery	Optional Accessory	Desk Dock (Optional) Vehicle Dock (without VGA output) (Optional) Vehicle Cradle (Optional) Battery Charger (Optional) Smart Card Reader (Optional) High Capacity Battery (Optional) Hand Strap (Optional) VESA Mount Kit (Optional) Shoulder Strap (Optional) Carry Bag (Optional) Vehicle Charger (Optional)
------------------	-----------------------------------------------------------------	---------------------------	----------------------------------------------------------------------------------------------------------------------------------------------------------------------------------------------------------------------------------------------------------------------------------------------------------------------------------------------

Barcode Scanner

Barcode Scanner 1D/2D Barcode Reader (Optional)

DIMENSIONS UNIT:MM

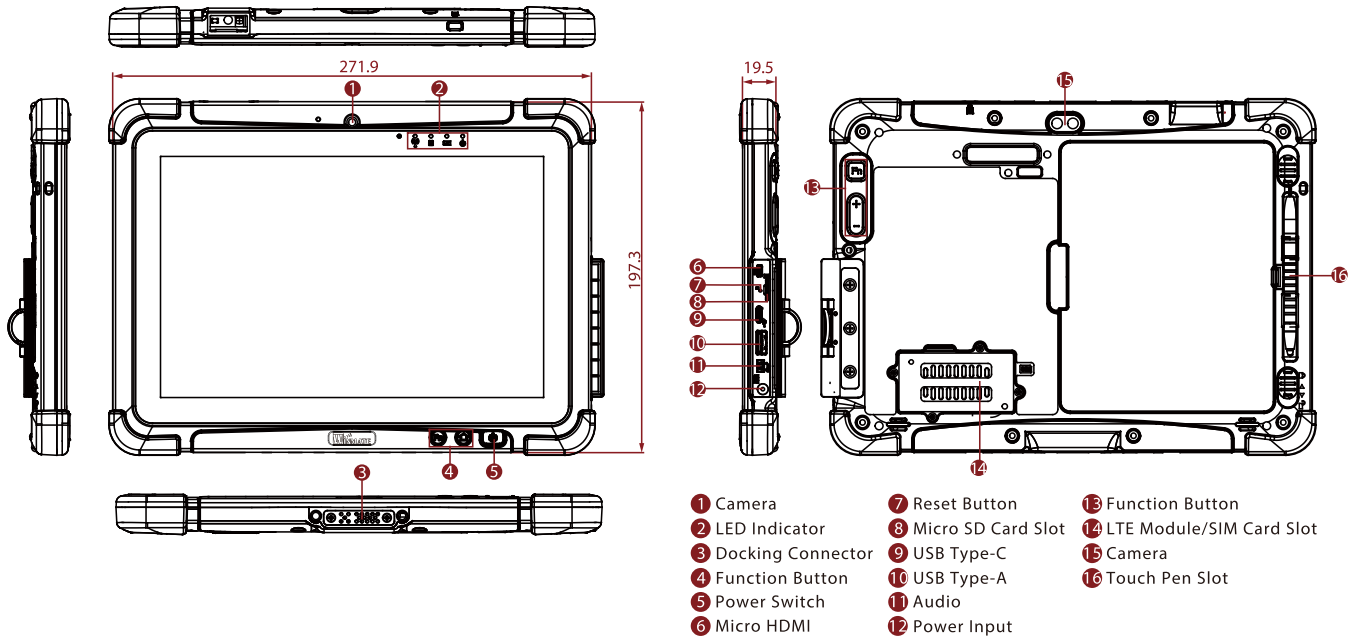

NOTE

1. Total usable memory will be less dependent upon actual system configuration.
2. The USB Type-C connector follows USB 3.0 standard, which does not support Alternate Mode (ALT).
3. Add-on modules require the expansion port option to be usable.
4. TPM 2.0 available upon request.
5. SOTI is available upon request.
6. Measured at dimming LCD brightness. Varies depending on the usage conditions, or when an external device is attached.
7. Length and weight measurements do not include protrusions.
8. The drop test with a high-capacity battery must come with a hand strap.
9. Accessories and Integrated Options may vary depending on your configuration.
10. This is a simplified drawing and some components are not marked in detail.
11. The product shown in this datasheet is a standard model. For diagrams that contain customized or optional I/O, please contact the Winmate Sales Team for more information.