

DESCRIPTION

The PM201 series comprising single and multiple output models for 150 to 200 watts of continuous output power is specially designed for medical application. They operate at 90 to 264 VAC input voltage without the need of a selector strap. All auxiliary outputs are with magnetic amplifier linear regulator to keep regulation. The units are constructed on a printed circuit board with a U-bracket for mechanical support and heat sinking. A cover and fan assembly can be added during manufacturing.

FEATURES

- Low safety ground leakage current
- Meet EN55011 Class B
- Power Factor 0.98 typical
- Short-circuit protection
- Power Fail Detect (PFD) signal
- 100% burn-in at full rated load
- Optional cover and fan assembly
- Remote inhibit - TTL high to disable output
- Compliant with RoHS requirements

INPUT SPECIFICATIONS

Input voltage:	90-264 VAC
Input frequency:	47-63 Hz
Input current:	3.20 A (rms) for 115 VAC 1.60 A (rms) for 230 VAC
Earth leakage current:	220 µA max. @ 264 VAC, 63 Hz
Touch current:	100 µA max. @ 264 VAC, 63 Hz

OUTPUT SPECIFICATIONS

Output voltage/current:	See rating chart.
Maximum output power:	See rating chart.
Ripple and noise:	2% peak to peak maximum on 3.3 V & 5.1 V and 1% peak to peak maximum on other voltage outputs
Over voltage protection:	Provided on output #1 only; set at 112-132% of its nominal output voltage, automatic recovery
Short circuit protection:	Automatic recovery
Over temperature protection:	Automatic recovery
Temperature coefficient:	All outputs $\pm 0.04\%$ /°C maximum
Transient response:	Maximum excursion of 4% or better on all models, recovering to 1% of final value within 500 µs after a 25% step load change
Fan power:	12 V at 200 mA maximum, except 24 V at 200 mA maximum for PM201-25B and PM201-27B, and 5 V at 380 mA maximum for PM201-40-3B

INTERFACE SIGNALS

PFD:	TTL logic high for normal operation and TTL logic low upon loss of input power. This signal appears at least 1ms prior to V1 output dropping 5% below its nominal value. This signal also provides a minimum delay of 100 ms after V1 is within regulation.
Inhibit:	Requires an external TTL high level signal to inhibit outputs for standard models

PM201 SERIES



CE

RoHS

SAFETY STANDARD APPROVALS



UL ES 60601-1, CSA C22.2 No. 60601-1
File No. E178020



TÜV EN60601-1

ENVIRONMENTAL SPECIFICATIONS

Operating temperature:	0°C to +70°C
Storage temperature:	-40°C to +85°C
Relative humidity:	5% to 95% non-condensing
Temperature derating:	Derate from 100% at +50°C linearly to 50% at +70°C
Cooling:	10.8 CFM forced air provided on "C" version; 25 CFM forced air to be provided for "B" version by user.

GENERAL SPECIFICATIONS

Switching frequency:	88-112 KHz
Efficiency:	70% minimum on all models
Hold-up time:	20 ms minimum at 110 VAC
Line regulation:	$\pm 0.5\%$ maximum at full load
Inrush current:	20 A @ 115 VAC or 40 A @ 230 VAC, at 25°C cold start
Withstand voltage:	5600 VDC from input to output (2 MOPP) 2100 VDC from input to ground (1 MOPP) 700 VDC from output to ground (To verify AC strength, get correct test method to avoid power supply damage.)
MTBF:	250,000 hours at full load at 25°C ambient, calculated per MIL-HDBK-217F
EMC Performance (EN60601-1-2)	
EN55011:	Class B conducted, class B radiated
EN61000-3-2:	Harmonic distortion, class A and D
EN61000-3-3:	Line flicker
EN60601-1-2	
EN61000-4-2:	ESD, ± 15 KV air and ± 8 KV contact
EN61000-4-3:	Radiated immunity, 9-28 V/m
EN61000-4-4:	Fast transient/burst, ± 2 KV
EN61000-4-5:	Surge, ± 1 KV diff., ± 2 KV com
EN61000-4-6:	Conducted immunity, 10 Vrms
EN61000-4-8:	Magnetic field immunity, 30 A/m
EN61000-4-11:	Voltage dip immunity, 30% reduction for 500 ms, 100% reduction for 10 ms

OUTPUT VOLTAGE/CURRENT RATING CHART

Model ⁽¹⁾	Output #1 ⁽⁴⁾				Output #2 ⁽²⁾⁽⁴⁾				Output #3				Output #4 ⁽³⁾				Max. Output Power ⁽⁴⁾
	V1	Imin.	Imax.	Tol.	V2	Imin.	Imax.	Tol.	V3	Imin.	Imax.	Tol.	V4	Imin.	Imax.	Tol.	
PM201-10B	5.1 V	3.0 A	35.0 A	±2%	(N/A)				(N/A)				(N/A)				87.5 W /175 W
PM201-10-3B	3.3 V	3.0 A	46.0 A	±3%	(N/A)				(N/A)				(N/A)				75 W /150 W
PM201-12B	12 V	1.2 A	16.7 A	±2%	(N/A)				(N/A)				(N/A)				100 W /200 W
PM201-13B	15 V	1.0 A	13.4 A	±2%	(N/A)				(N/A)				(N/A)				100 W /200 W
PM201-14B	24 V	0.6 A	8.4 A	±2%	(N/A)				(N/A)				(N/A)				100 W /200 W
PM201-16B	30 V	0.5 A	6.7 A	±2%	(N/A)				(N/A)				(N/A)				100 W /200 W
PM201-18B	48 V	0.5 A	4.2 A	±2%	(N/A)				(N/A)				(N/A)				100 W /200 W
PM201-23B	+5.1 V	3.0 A	30.0 A	±2%	+12 V	0 A	8 A	±4%	(N/A)				(N/A)				100 W /200 W
PM201-24B	+5.1 V	3.0 A	30.0 A	±2%	+15 V	0 A	6 A	±4%	(N/A)				(N/A)				100 W /200 W
PM201-25B	+5.1 V	3.0 A	30.0 A	±2%	+24 V	0 A	4 A	±4%	(N/A)				(N/A)				100 W /200 W
PM201-27B	+12 V	1.0 A	8.7 A	±2%	+24 V	0 A	4 A	±4%	(N/A)				(N/A)				100 W /200 W
PM201-30B	+5.1 V	3.0 A	30.0 A	±2%	+12 V	0 A	8 A	±4%	-5 V	0 A	6 A	±4%	(N/A)				100 W /200 W
PM201-31B	+5.1 V	3.0 A	30.0 A	±2%	+12 V	0 A	8 A	±4%	-12 V	0 A	4 A	±4%	(N/A)				100 W /200 W
PM201-32B	+5.1 V	3.0 A	30.0 A	±2%	+15 V	0 A	6 A	±4%	-15 V	0 A	4 A	±4%	(N/A)				100 W /200 W
PM201-33B	+5.1 V	3.0 A	30.0 A	±2%	+15 V	0 A	6 A	±4%	-12 V	0 A	4 A	±4%	(N/A)				100 W /200 W
PM201-36B	+5.1 V	3.0 A	30.0 A	±2%	+12 V	0 A	8 A	±4%	24 V	0 A	4 A	±4%	(N/A)				100 W /200 W
PM201-40B	+5.1 V	3.0 A	30.0 A	±2%	+12 V	0 A	8 A	±4%	-12 V	0 A	4 A	±4%	5 V	0 A	6 A	±4%	100 W /200 W
PM201-41B	+5.1 V	3.0 A	30.0 A	±2%	+15 V	0 A	6 A	±4%	-15 V	0 A	4 A	±4%	24 V	0 A	4 A	±4%	100 W /200 W
PM201-42B	+5.1 V	3.0 A	30.0 A	±2%	+12 V	0 A	8 A	±4%	-12 V	0 A	4 A	±4%	12 V	0 A	4 A	±4%	100 W /200 W
PM201-44B	+5.1 V	3.0 A	30.0 A	±2%	+12 V	0 A	8 A	±4%	-15 V	0 A	4 A	±4%	15 V	0 A	4 A	±4%	100 W /200 W
PM201-45B	+5.1 V	3.0 A	30.0 A	±2%	+12 V	0 A	8 A	±4%	-12 V	0 A	4 A	±4%	24 V	0 A	4 A	±4%	100 W /200 W
PM201-40-3B	+3.3 V	3.0 A	30.0 A	±3%	+5.1 V	0 A	8 A	±4%	-12 V	0 A	4 A	±4%	12 V	0 A	4 A	±4%	87.5 W /175 W

NOTES:

- Suffix "B" in model numbers denotes U-bracket form. Change "B" to "C" for enclosed form with cover and fan assembly, e.g. PM201-45C.
- Peak output current is 12 A on +12 V, 9 A on +15 V and 6 A on +24 V.
- Output #4 is floating. It can be connected externally for positive or negative output.
- 200 watts for "C" version with a cover and fan assembly. 100 watts for "B" version without moving air (maximum current of output #1 & #2 derated to 50%), or 200 watts with 25 CFM forced air provided by user.
- When the remote Sense facility is not used, +Sense must be connected to +V, and -Sense to return, on P2 connector.
- All models may be operated at no-load. At no-load, output voltage tolerance increases to ±10%.
- Ripple and noise is maximum peak to peak voltage value measured at output within 20 MHz bandwidth, at rated line voltage and output load ranges, and with a 10 µF tantalum capacitor in parallel with a 0.1 µF ceramic capacitor across the output.

OUTPUT POWER DERATING CURVE

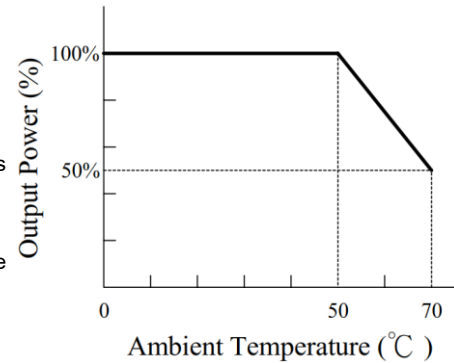

MECHANICAL SPECIFICATIONS (SINGLE OUTPUT MODELS)

U-bracket Form

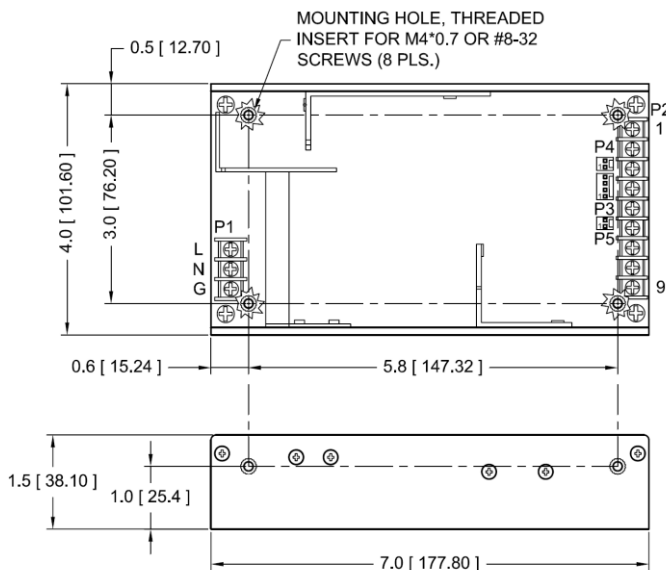

Enclosed Form

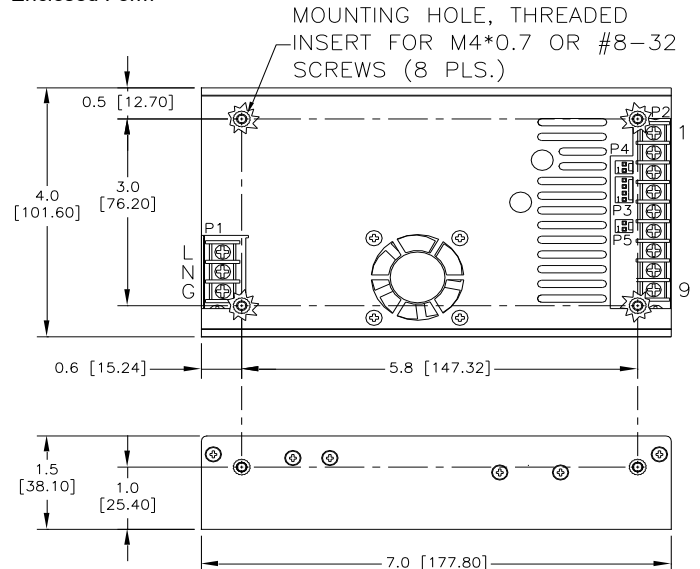

MECHANICAL SPECIFICATIONS (MULTIPLE OUTPUT MODELS)

U-bracket Form

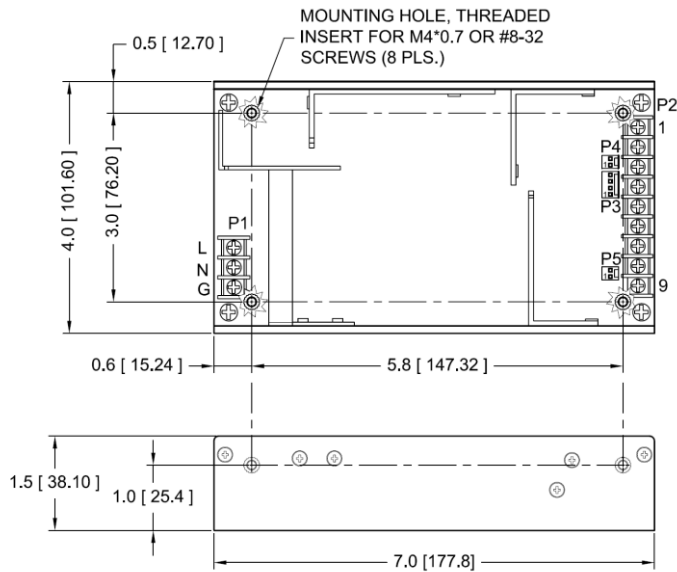

Enclosed Form

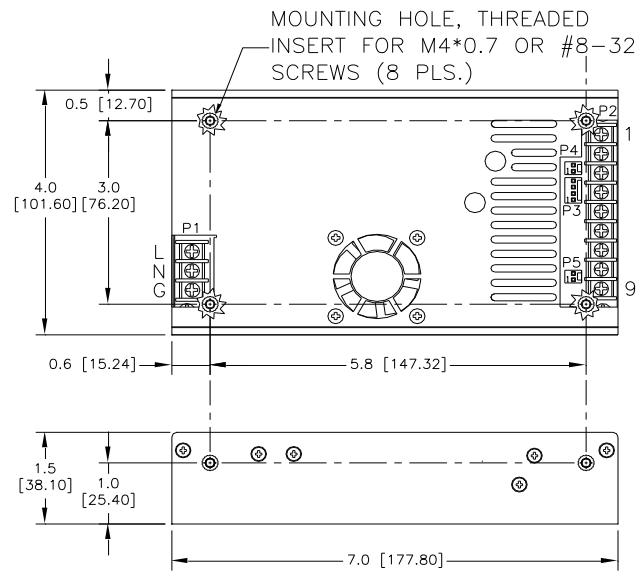

NOTES:

1. Dimensions shown in inches [mm]; tolerance 0.02 [0.5] maximum.
2. Input connector P1 is Dinkle DT-35-B01W-03. Output connector P2 is Dinkle DT-35-B01W-09. Screws are M3, nickel plated.
3. Connector P3 mates with Molex housing 22-01-1042 and Molex 2759 or 5159 series crimp terminal.
4. Connectors P4 and P5 mate with Molex housing 22-01-1022 and Molex 2759 or 5159 series crimp terminal.
5. P4 is for DC fan, 12 V/0.2 A rated, Pin 1 +V and Pin 2 -V; except 24 V/0.2 A rated for models PM201-25 and PM201-27, and 5 V/0.38 A rated for models PM201-40-3.
6. Weight: 820 grams (1.8 lbs.) approx. for U-bracket form, 960 grams (2.1 lbs.) approx. for enclosed form.
7. Maximum penetration depth of fixing screws is 4 mm from the outer surface of chassis.

PIN CHART

MODEL	CONN PIN	P2									P3				P5	
		1	2	3	4	5	6	7	8	9	1	2	3	4	1	2
PM201-10B PM201-10-3B PM201-12B PM201-13B	PM201-14B PM201-16B PM201-18B	-Sense	Com. Ret.	Com. Ret.	Com. Ret.	Com. Ret.	+V1	+V1	+V1	+Sense	Fan +V	Com. Ret.	Com. Ret.	PFD	Inhibit +V	Inhibit -V
PM201-23B PM201-24B	PM201-25B PM201-27B	V1	V1	Com. Ret.	Com. Ret.	Com. Ret.	V2	N.C.	N.C.	N.C.	Fan +V	Com. Ret.	Com. Ret.	PFD	Inhibit +V	Inhibit -V
PM201-30B PM201-31B	PM201-32B PM201-33B	V1	V1	Com. Ret.	Com. Ret.	Com. Ret.	V2	V3	N.C.	N.C.	Fan +V	Com. Ret.	Com. Ret.	PFD	Inhibit +V	Inhibit -V
PM201-36B		V1	V1	Com. Ret.	Com. Ret.	Com. Ret.	V2	N.C.	V3 Return	+V3	Fan +V	Com. Ret.	Com. Ret.	PFD	Inhibit +V	Inhibit -V
PM201-40B PM201-41B PM201-42B	PM201-44B PM201-45B PM201-40-3B	V1	V1	Com. Ret.	Com. Ret.	Com. Ret.	V2	V3	V4 Return	+V4	Fan +V	Com. Ret.	Com. Ret.	PFD	Inhibit +V	Inhibit -V