

## DESCRIPTION

The PMP122 series of AC/DC switching power supplies are for 96-120 watts of continuous output power. They are enclosed in a 94V-0 rated polycarbonate case with an IEC320/C14, C6, C8 or C18 inlet to mate with interchangeable cord for world-wide use. All models meet EN55011 class B emission limits, and are designed for medical applications.

## FEATURES

- No load power consumption less than 0.15W
- Meet Energy Star EPS2.0 /ErP EC No 278/2009 (Lot 7)
- Meet EU CoC EPS V5 Tier 2
- With PFC circuit
- Low profile at 28mm
- Operating altitude up to 5000 meters
- Wide input range 80 to 264 VAC
- Enclosure meets IP54
- Optional output connectors
- 100% burn-in
- Overvoltage protection
- Overcurrent protection
- Compliant with RoHS requirements

## INPUT SPECIFICATIONS

Input voltage:	80-264 VAC
Power derating:	Derate linearly from 100% at 90 VAC to 90% at 85Vac and 80% at 80 VAC
Input frequency:	47-63 Hz
Input current:	1.60 A (rms) for 115 VAC 0.80 A (rms) for 230 VAC
Earth leakage current:	180 $\mu$ A max. @ 264 VAC, 63 Hz
Touch current:	100 $\mu$ A max. @ 264 VAC, 63 Hz

## OUTPUT SPECIFICATIONS

Output voltage /current:	See rating chart.
Maximum output power:	See rating chart.
Ripple and noise:	1% peak to peak maximum
Over voltage protection:	Provided and set at 112-140% of its nominal output voltage, latching by recycle input to reset
Short circuit protection:	Automatic recovery
Over temperature protection:	Latching by recycle input to reset
Temperature coefficient:	$\pm 0.04\%$ / $^{\circ}$ C maximum
Transient response:	Maximum excursion of 4% or better on all models, recovering to 1% of final value within 500 us after a 25% step load change

## ENVIRONMENTAL SPECIFICATIONS

Operating temperature:	-20 $^{\circ}$ C to +60 $^{\circ}$ C
Atmospheric pressure:	540 hPa to 1060 hPa
Storage temperature:	-40 $^{\circ}$ C to +85 $^{\circ}$ C
Relative humidity:	5% to 95% non-condensing
Temperature derating:	Derate from 100% at +40 $^{\circ}$ C linearly to 50% at +60 $^{\circ}$ C
Ingress protection:	IP54

## PMP122 SERIES



## SAFETY STANDARD APPROVALS



UL ES 60601-1, CSA C22.2 No. 60601-1  
File No. E178020



TÜV EN 60601-1

## GENERAL SPECIFICATIONS

Switching frequency:	50-130 KHz
Power factor:	0.98 Typical at 115 VAC
Efficiency:	88% min. at full load
Hold-up time:	20 ms minimum at 100 VAC
Line regulation:	$\pm 0.5\%$ maximum at full load
Inrush current:	90 A @ 115 VAC or 180 A @ 230 VAC, at 25 $^{\circ}$ C cold start
Withstand voltage:	4000 VAC from input to output (2 MOPP) 1500 VAC from input to ground (1 MOPP) 500 VAC from output to ground (For class II models, 4000VAC from input to output)
MTBF:	100,000 hours at full load at 25 $^{\circ}$ C ambient, calculated per MIL-HDBK-217F
EMC Performance	
EN55011:	Class B conducted, class B radiated
EN61000-3-2:	Harmonic distortion, class A and D
EN61000-3-3:	Line flicker
EN60601-1-2	
EN61000-4-2:	ESD, $\pm 15$ KV air and $\pm 8$ KV contact
EN61000-4-3:	Radiated immunity, 9-28 V/m
EN61000-4-4:	Fast transient/burst, $\pm 2$ KV
EN61000-4-5:	Surge, $\pm 1$ KV diff., $\pm 2$ KV com.
EN61000-4-6:	Conducted immunity, 10 Vrms
EN61000-4-8:	Magnetic field immunity, 30 A/m
EN61000-4-11:	Voltage dip immunity, 30% reduction for 500 ms (criteria A @ 230VAC, criteria B @ 100VAC), 60% reduction for 100 ms (criteria A @ 230VAC, criteria B @ 100VAC) and >95% reduction for 20 ms

## OUTPUT VOLTAGE/CURRENT RATING CHART

Model		Output						Average Active Efficiency (typical) @ 115 / 230 Vac
Class I <sup>(1)</sup>	Class II <sup>(2)</sup>	V1	Min. Current	Max. Current	Tol.	Ripple & Noise <sup>(3)</sup>	Max. Power	
PMP122-12	PMP122F-12	12 V	0 A	8.00 A	±5%	120 mV	96 W	89 /89%
PMP122-13	PMP122F-13	15 V	0 A	7.00 A	±5%	150 mV	105 W	89 /89%
PMP122-13-1	PMP122F-13-1	18 V	0 A	6.67 A	±5%	180 mV	120 W	89 /89%
PMP122-13-2	PMP122F-13-2	19 V	0 A	6.32 A	±5%	190 mV	120 W	89 /89%
PMP122-13-3	PMP122F-13-3	20 V	0 A	6.00 A	±5%	200 mV	120 W	89 /89%
PMP122-14	PMP122F-14	24 V	0 A	5.00 A	±5%	240 mV	120 W	90 /90%
PMP122-16	PMP122F-16	30 V	0 A	4.00 A	±5%	300 mV	120 W	90 /90%
PMP122-17	PMP122F-17	36 V	0 A	3.34 A	±5%	360 mV	120 W	90 /90%
PMP122-18	PMP122F-18	48 V	0 A	2.50 A	±5%	480 mV	120 W	90 /90%

### NOTES:

- Class I models are equipped with IEC320/C14 inlet. To order a model with C6 inlet, add "S" to the prefix, PMP122, of model number, e.g. PMP122S-12.
- Class II models are equipped with IEC320/C18 inlet. To order a model with C8 inlet, change "F" in the prefix of model number to "SF", e.g. PMP122SF-12.
- Ripple and noise is maximum peak to peak voltage value measured at output within 20 MHz bandwidth, at rated line voltage and output load ranges, and with a 47 µF electrolytic capacitor in parallel with a 0.1 µF ceramic capacitor across the output.

## MECHANICAL SPECIFICATIONS

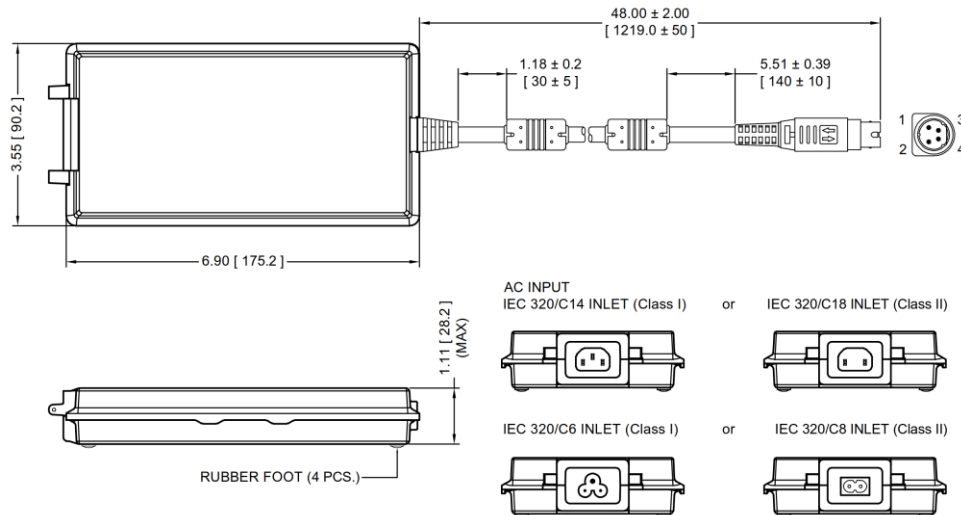

### NOTES:

- Dimensions shown in inches [mm], tolerance 0.02 [0.5] maximum.
- Weight: 550 grams (1.213 lbs.) approx.
- Output connector is 4 pin plug without lock, mating with Kycon P/N KPJX-4S-S socket or equivalent.
- Refer to Section titled "OPTIONAL OUTPUT CONNECTORS". Add the suffix assigned for a selected connector to a wanted model number, e.g. PMP122-14-B1, for ordering.

## OUTPUT POWER DERATING CURVE

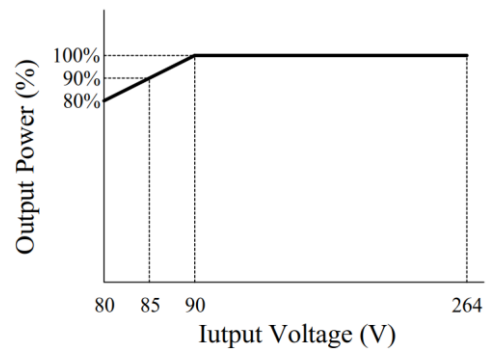
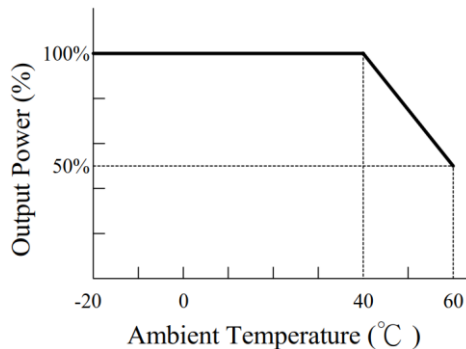

## PIN CHART

PIN NO.	1	2	3	4
Polarity	V1 Return	+V1	V1 Return	+V1