

# GNSS mPCIe/M.2 Cards

## ANNA Series User Manual

Version 1.3

Dec 22, 2020

### ANNA-M Series

M.2 2242 B key



### ANNA-F Series

Mini PCIe



### **ANTZER TECH CO., LTD.**

Website : [www.antzer-tech.com](http://www.antzer-tech.com)

Facebook : [www.facebook.com/ANTZERTECH/](https://www.facebook.com/ANTZERTECH/)

Tel : +886-2-7729-9223

Email : [sales@antzer-tech.com](mailto:sales@antzer-tech.com)

Office : 7F-7, No.237, Sec. 1, Datong Rd., Xizhi Dist., New Taipei City 221 Taiwan

## Important User Information

### Liability

Every care has been taken in the preparation of this document. Please inform ANTZER TECH CO., LTD. any inaccuracies or omissions. The data and illustrations found in this document are not binding. We, ANTZER TECH CO., LTD. reserve the right to modify our products in line with our policy of continuous product development. The information in this document is subject to change without notice and therefore should not be considered as a binding description of the range of functions (neither for future product versions). ANTZER TECH CO., LTD. assumes no responsibility for any errors that may appear in this document.

There are many applications of the described product. Those responsible for the use of this device must ensure that all the necessary steps have been taken to verify that the applications meet all performance and safety requirements including any applicable laws, regulations, codes, and standards.

ANTZER TECH CO., LTD. will under no circumstances assume liability or responsibility for any problems that may arise as a result from improper use or use that is not in accordance with the documented features of this product.

The examples and illustrations in this document are included solely for illustrative purposes.

### Intellectual Property Rights

ANTZER TECH CO., LTD. has intellectual property rights relating to technology embodied in the product described in this document. These intellectual property rights may include patents and pending patent applications in Taiwan and other countries.

Copyright © 2020 ANTZER TECH CO., LTD. All rights reserved.

Antzer Tech In-Vehicle Cards User Manual

## Table of Contents

1. Introduction .....	4
2. Specification .....	4
3. Dimensions .....	5
3.1. ANNA-F Series (Mini PCIe) .....	5
3.2. ANNA-M Series (M.2 2242 B-key) .....	5
4. Connectors and Pin Assignment .....	6
4.1. GNSS IPEX Antenna Connector .....	6
4.2. ADR Connector (only for the SKU with NEO-M8L) .....	7
4.3. CAN Bus Connector (only for ANNA-F series with NEO-M8L).....	7
4.4. Functional Switch (only for ANNA-F series) .....	7
5. Back-up Battery for GNSS module .....	7
6. Driver .....	8
7. Reliability Specifications .....	9
7.1. Environmental .....	9
7.2. Certification and Compliance .....	9
8. Ordering Information .....	10
8.1. Naming Rules .....	10
8.2. Part Number .....	11
Appendix A Optional Cable & Accessory .....	12

## Change History

Version	Date	Author	Description
<b>1.0</b>	2020/7/6	Haney Huang	First version release
<b>1.1</b>	2020/7/13	Haney Huang	Added driver information to the document
<b>1.2</b>	2020/7/16	Haney Huang	Fixed the typo in Chapter 8.2
<b>1.3</b>	2020/12/22	Haney Huang	<ol style="list-style-type: none"><li>1. Updated the SKU in ordering information</li><li>2. Modified the naming rules</li><li>3. Added cable P/N in Appendix A</li></ol>

## 1. Introduction

ANTZER TECH's ANNA Mini-PCIe/M.2 card integrates high performing u-blox M8 module that have concurrent reception of up to 3 GNSS (GPS/Galileo together with GLONASS or BeiDou). ANNA series has optional configurations which support Dead Reckoning Technology: UDR (Untethered Dead Reckoning), ADR (Automotive Dead Reckoning) or Antzer Tech patented CAN-to-ADR solution [\*]. ANNA Mini-PCIe/M.2 card provides outstanding positioning accuracy which is the ideal solution for industrial and automotive applications.

[\*] The CAN-to-ADR function is only available on ANNA-F (Mini-PCIe) series.

## 2. Specification

Interface	Form Factor	<b>ANNA-F/H:</b> Full/Half Sized PCI Express Mini Card <b>ANNA-M:</b> M.2 2242 B-Key
	Host Interface	USB 2.0 via PCI Express Mini Card Socket / M.2 B-key * Optional SKU with sensors via I <sup>2</sup> C interface
GNSS	GNSS Module	u-blox NEO-M8N, NEO-M8U, NEO-M8L
	Receiver Type	72-channel u-blox M8 engine Concurrent reception of up to 3 GNSS (GPS, Galileo, GLONASS, BeiDou)
	Position Accuracy	2.0m CEP
	Dead Reckoning	UDR / ADR / CAN-to-ADR (only for ANNA-F series)
	Quick Hot Start	Supported (Li-Coin Battery is Required)
	GNSS Antenna	External, IPEX connector onboard (Default Support Active Antenna) * Optional SKU for Passive Antenna
	Input Connector	Wheel-tick and Direction Inputs for the ADR SKU
CAN/Sensor	Sensor (Optional SKU)	3D Gyroscope 3D Accelerometer
	CAN (Only for CAN-to-ADR SKU)	Support ISO15765-4 On-Board Diagnostic or J1939 Protocol to Get Speed from Vehicle CAN Bus for CAN-to-ADR Application.
Environment	Operating Temp	-40°C ~ 85°C (without Li-Coin Battery) -20°C ~ 60°C (with Li-Coin Battery)
	Vibration Test	Pass 7.69G@ 20~2000Hz, compliant with MIL-STD-810G category 24
	ESD Protection	8kV Contact, 15kV air
	Certification	CE, FCC Class B

### 3. Dimensions

#### 3.1. ANNA-F Series (Mini PCIe)

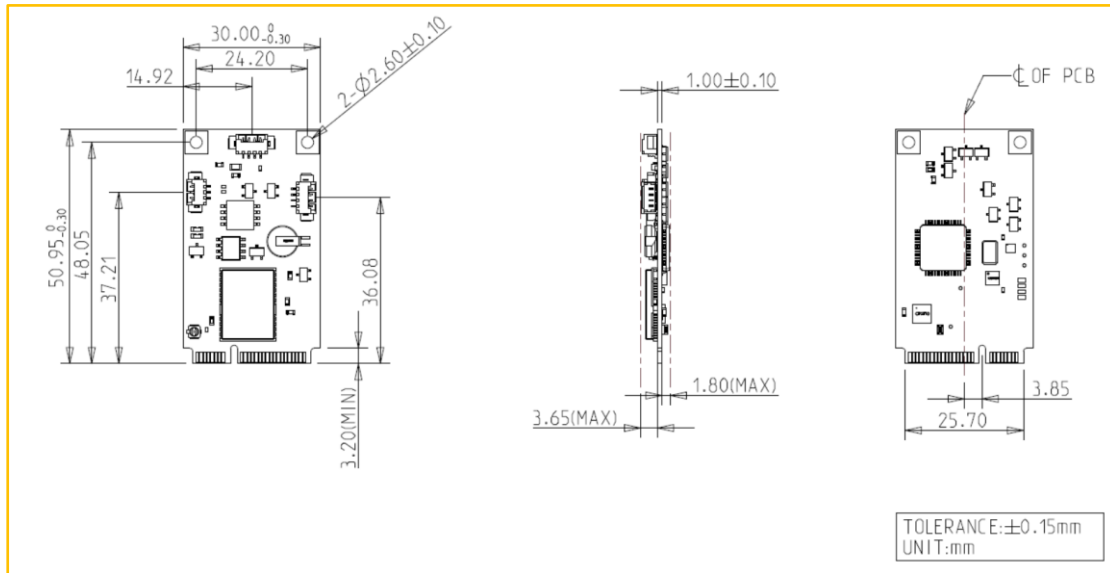

#### 3.2. ANNA-M Series (M.2 2242 B-key)

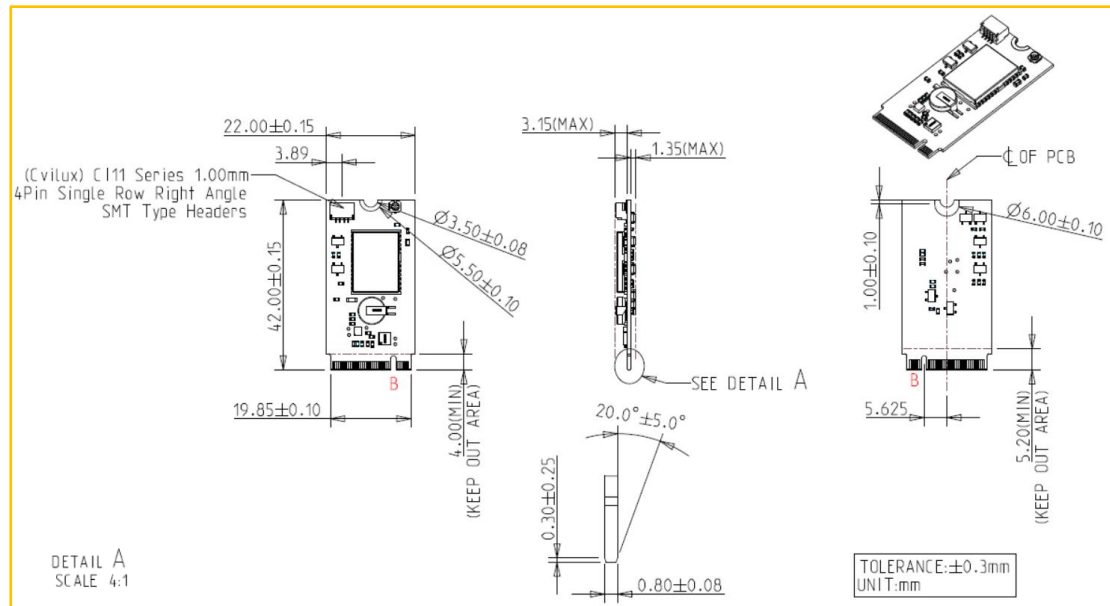

## 4. Connectors and Pin Assignment

### ANNA-F Series

Mini PCIe

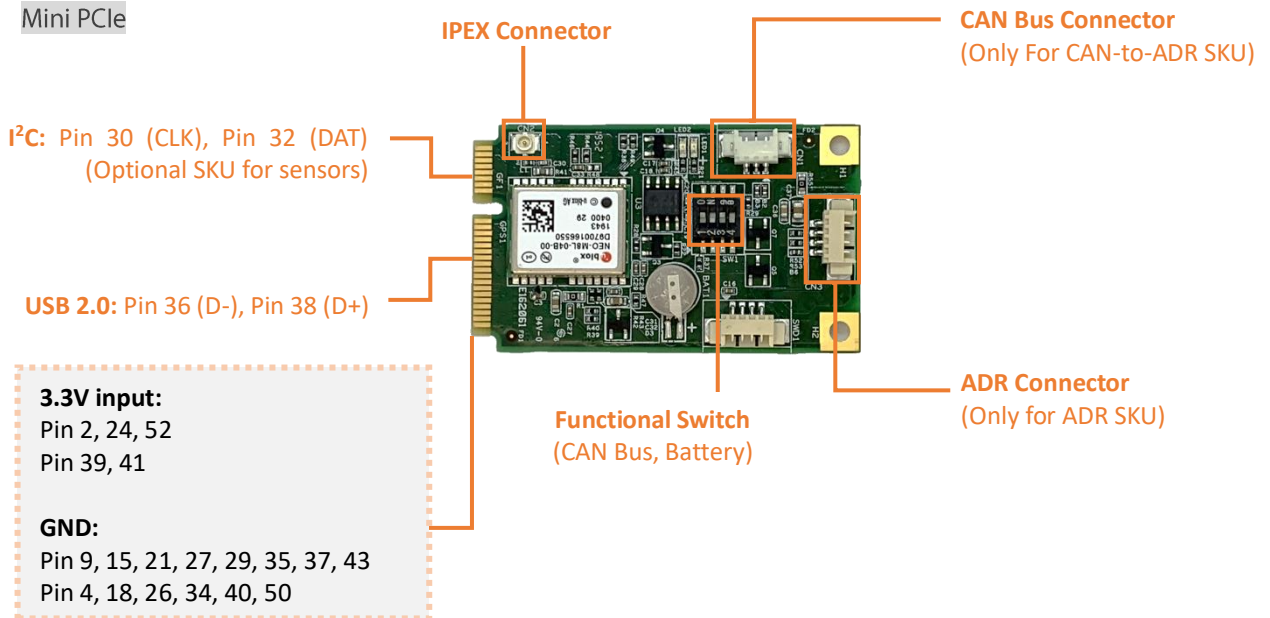

### ANNA-M Series

M.2 2242 B key

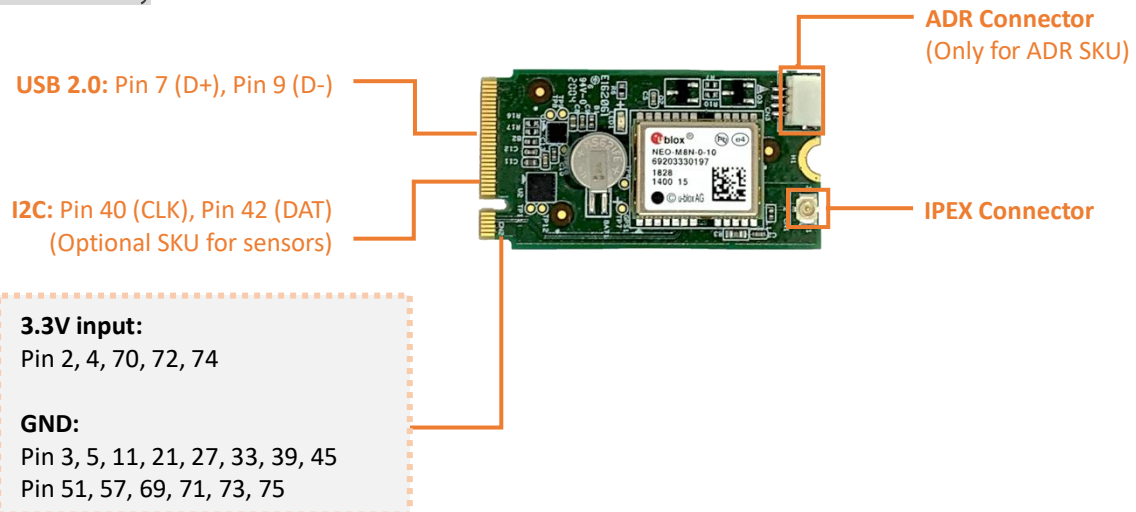

### 4.1. GNSS IPEX Antenna Connector

Coaxial cable connector: 3 pin, 180°, Female, 3V, SMD  
 Manufacture part number: U.FL-R-SMT-1(10), Hirose

## 4.2. ADR Connector (only for the SKU with NEO-M8L)

- **ANNA-F Series:**  
WAFER BOX, 1x4 pin, pitch:1.25mm, 90°, Male, SMD  
Manufacture part number: CI4404M1HR0-NH, CviLux
- **ANNA-M Series:**  
WAFER BOX, 1x4 pin, pitch:1.0mm, 90°, Male, SMD  
Manufacture part number: CI1104M1HR0-NH, CviLux

## 4.3. CAN Bus Connector (only for ANNA-F series with NEO-M8L)

WAFER BOX, 1x3 pin, pitch:1.25mm, 90°, Male, SMD  
Manufacture part number: CI4403M1HR0-NH, CviLux

## 4.4. Functional Switch (only for ANNA-F series)

- **SW #1:** Reserved
- **SW #2:** Back-up Battery ON/OFF (Default: ON)
- **SW #3:** CAN bus Tx ON/OFF (Default: ON)
- **SW #4:** CAN bus Terminal Resistor (Default: OFF)

## 5. Back-up Battery for GNSS module

Lithium Rechargeable Battery, 5mAh, 3V  
Manufacture part number: MS621FE, Seiko

- The modified settings of the GNSS module remain effective until power-down or reset. If these settings have been stored in BBR (Battery Backed RAM), then the modified configuration will be retained, as long as the backup battery supply is not interrupted.
- With the default setting of SW2 to be "ON", our card will enable the battery when main power is connected. After enabled, the battery might over-discharge without the main power of the card if you store it for a long time. To prevent that, after the main power is removed, turn the SW2 from "ON" to "OFF" and then switch back to "ON" before storage. The battery will not be enabled until power-up.



## 6. Driver

We use CP210x UART to USB bridge IC on our card.

- **Windows driver:**

Please download the driver from the official website of Silicon Labs:

<https://www.silabs.com/products/development-tools/software/usb-to-uart-bridge-vcp-drivers>

- **Linux driver:**

The driver is already included in Ubuntu 14.04 and later.

The Linux 3.x.x and 4.x.x version of the driver is maintained in the current Linux 3.x.x and 4.x.x tree at [www.kernel.org](http://www.kernel.org).

- **Find the COM port of the GNSS module:**

The GNSS module is connected to Host PC through “Standard COM Port”.

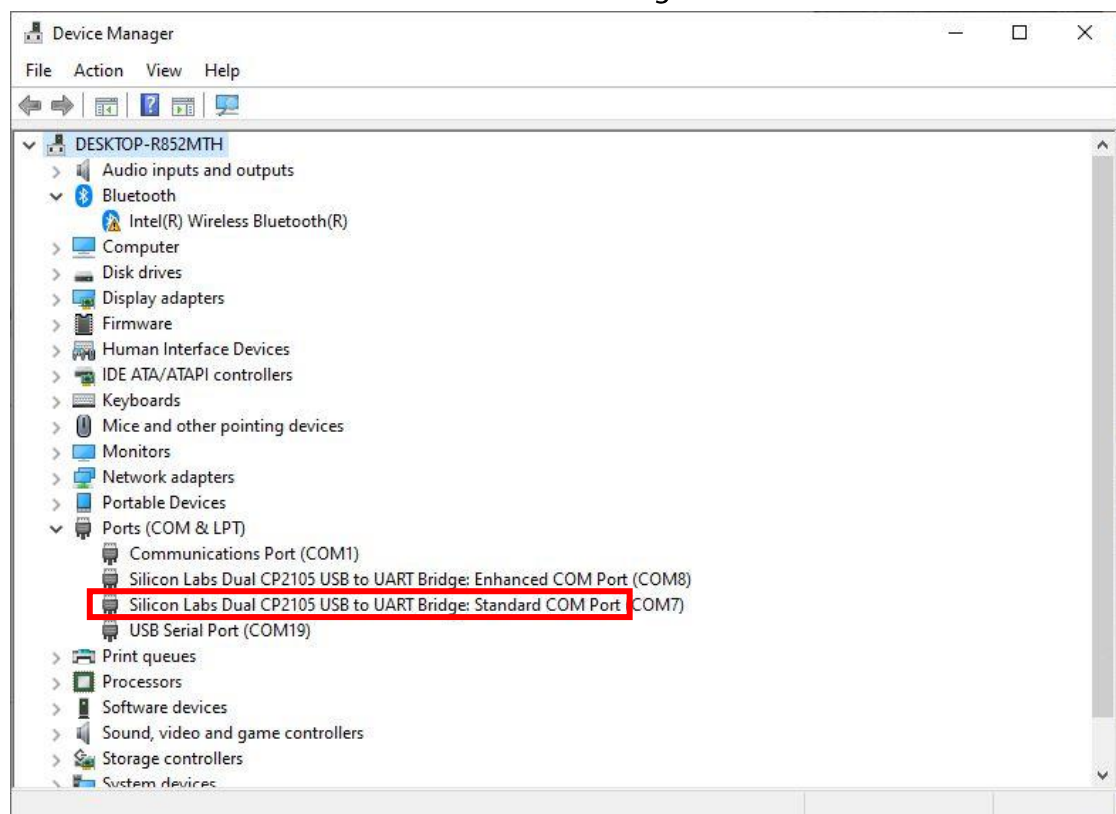

- **Fix the COM port number on your PC:**

If it is necessary, please execute CP21xWR patch provided by Antzer Tech after the driver installation to fix the COM port number on your PC.

## 7. Reliability Specifications

### 7.1. Environmental

Environment	Specifications
Temperature	Operating: -40°C to 85°C (without Li-Coin Battery) Operating: -20°C to 60°C (with Li-Coin Battery)
Vibration	Operating: Random, 7.69(Grms), 20~2000(Hz) Compliant with MIL-STD-810G

### 7.2. Certification and Compliance

The ANNA series product complies with the following standards:

- CE
- FCC
- RoHS
- MIL-STD-810G Vibration Compliant

## 8. Ordering Information

### 8.1. Naming Rules

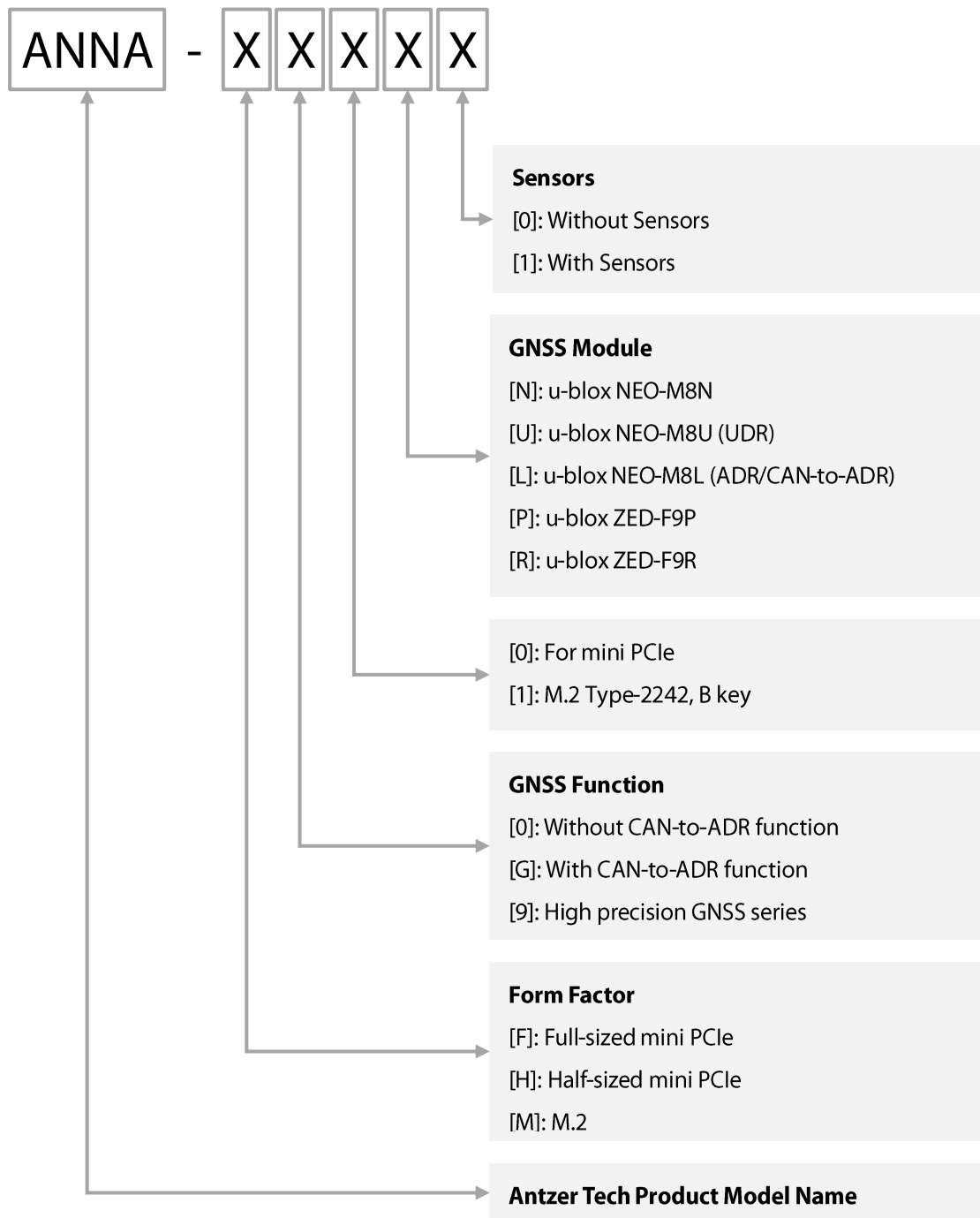

## 8.2. Part Number

Form Factor \ GNSS Feature	ANNA-F/H Series		ANNA-M Series	
	Mini PCIe		M.2 2242 B-Key	
	w/o Sensors	w/ Sensors <sup>[1]</sup>	w/o Sensors	w/ Sensors <sup>[3]</sup>
<b>Standard</b>	ANNA-H00N0 ANNA-F00N0	ANNA-H00N1 ANNA-F00N1	ANNA-M01N0	ANNA-M01N1
<b>UDR</b>	ANNA-H00U0 ANNA-F00U0	ANNA-H00U1 ANNA-F00U1	ANNA-M01U0	ANNA-M01U1
<b>ADR</b>		ANNA-F00L1	ANNA-M01L0	ANNA-M01L1
<b>CAN-to-ADR</b>		ANNA-FG0L1 <sup>[2]</sup>		

### [1]

The default interface of the sensors is I2C on the mPCIe socket. Please contact our sales representative if you need the SKU with USB 2.0 interface for the sensors.

### [2]

For the SKU with CAN-to-ADR function, the default interface of the sensors would be USB 2.0 on the mPCIe socket.

### [3]

The interface of the sensors is I2C on the M.2 socket.

## Appendix A Optional Cable & Accessory

- Cable: T1700000032 (For **CAN-to-ADR** Application)  
**ANNA CAN bus cable**, Box Header 3P to DB9 (Male) Cable, 1 ch CAN, 200mm

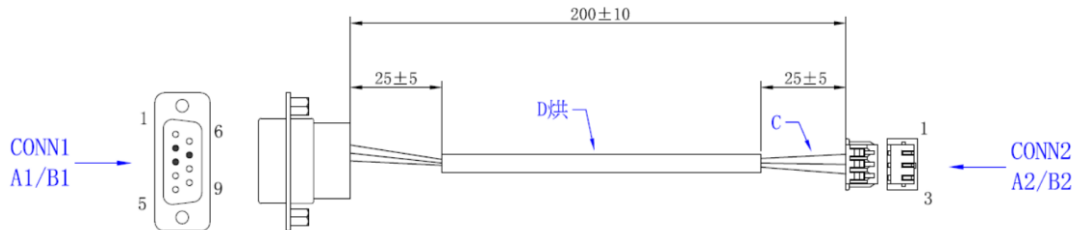

CONN1		CONN2	
PIN No.	FUNCTION	COLOR	PIN No.
2	CAN_Low	BROWN	2
3	GND	BLACK	3
7	CAN_High	RED	1

- Cable: T1700000021  
**ADR Cable for ANNA-F**, Wafer Box 1.25mm to D-SUB 9 Pin Male, ADR 250mm

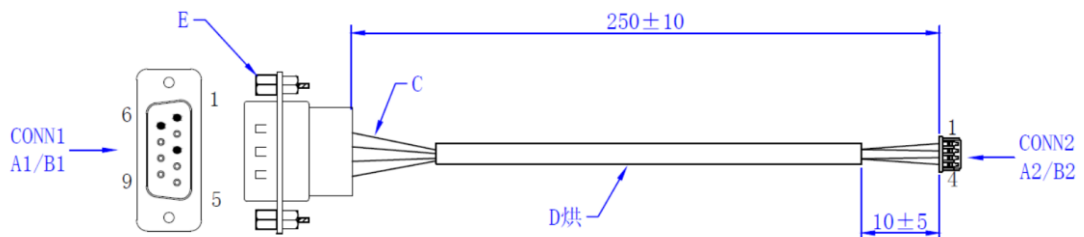

CONN1		CONN2	
PIN No.	FUNCTION	COLOR	PIN No.
1	Wheel-tick Signal	RED	3
3	GND	BLACK	4
6	Reverse Signal	BROWN	2

- Cable: T1700000035  
**ADR Cable for ANNA-M, Wafer Box 1.0 mm to D-SUB 9 Pin Male, ADR 250mm**

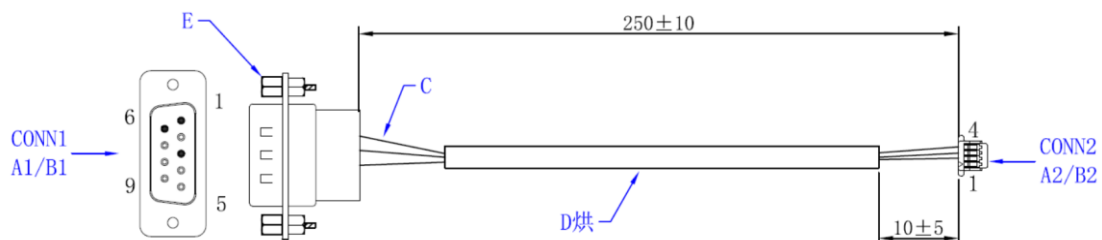

CONN1		CONN2	
PIN No.	FUNCTION	COLOR	PIN No.
1	Wheel-tick Signal	RED	3
3	GND	BLACK	4
6	Reverse Signal	BROWN	2