

# R15IK3S-SPC369-P1

## 15" Intel® Core™ i5 IP69K Stainless P Series Panel PC



### KEY FEATURES

- Intel® Core™ i5-7200U, 2.50 GHz
- Fanless cooling system
- SUS316 / AISI 316 stainless steel for food and chemical industries
- Full IP69K waterproof enclosure
- A true flat, easy-to-clean front surface with edge-to-edge design
- Waterproof sealed conduit pipe for cable protection
- Support VESA mount, and optional Yoke mount stand
- Support Glove/ Rain mode
- Optical bonding (optional)



### SPECIFICATIONS

Display	
<b>Resolution</b>	1024x768
<b>Contrast Ratio</b>	2000:1
<b>View Angles</b>	88,88,88,88
<b>Touch / Glass</b>	Projected Capacitive Multi Touch Screen
<b>Size</b>	15 inches
<b>Panel Brightness</b>	300 nits
<b>Active Area</b>	304.1x228.1 mm
System Specification	
<b>Processor</b>	Intel Core i5-7200U 2.5GHz (up to 3.1GHz) Intel Core i5-7300U 2.6GHz (up to 3.5GHz) (Optional)
<b>Memory</b>	1 x SO-DIMM, DDR4 2133 MHz, 4GB 8GB (Optional) 16GB (Optional)
<b>Storage</b>	1 x M.2 2242 SSD 128GB M.2 2242 SSD up to 512GB (Optional)
<b>Ethernet controller</b>	2 x Intel® Ethernet Controller
<b>Security</b>	TPM 2.0
<b>Operating System</b>	Windows 10 IoT Enterprise (64 bit) (Optional) Linux Ubuntu 20.04 (Optional)
<b>WLAN</b>	Support (Optional)
<b>BT</b>	Support (Optional)
Mechanical	
<b>Dimension</b>	378 x 301 x 56.2 mm
<b>Mounting</b>	VESA Mount Yoke Mount
<b>Enclosure</b>	Stainless Housing
<b>Cooling System</b>	Fanless design
Environment	
<b>Operating Humidity</b>	10% to 90% RH, Non-Condensing
<b>Operating Temperature</b>	0°C to 45°C
<b>Storage Temperature</b>	-20°C to 60°C
<b>IP rating</b>	IP69K
Certification	
<b>Certification</b>	CE, FCC
IO Ports	
<b>USB Port</b>	2 x USB3.2 Gen1x1 (Type-A)
<b>Serial Port</b>	1 x RS232/422/485 (Default RS232)
<b>Video</b>	1 x HDMI 1.4
<b>LAN</b>	2 x Giga LAN RJ45 Connector
<b>Indicator</b>	1 x LED Indicator on power button
Control	
<b>Button</b>	1 x Power Button

## Accessory

### Accessory

1 x Waterproof Conduit 1.5m  
 1 x Waterproof Conduit 0.3m  
 2 x Elbow for connect the conduit  
 1 x AC to DC power adapter with power cord  
 1 x D-sub9(male) to RJ45 adapter  
 1 x D-sub9(female) to RJ45 adapter  
 1 x External RJ45 male to male cable  
 VESA screws

### Optional Accessory

1 x Open wire cable for phoenix connector (Optional)  
 Yoke mount stand kit (Optional)

## Power

Power Rating 12V DC

## DIMENSIONS UNIT:MM

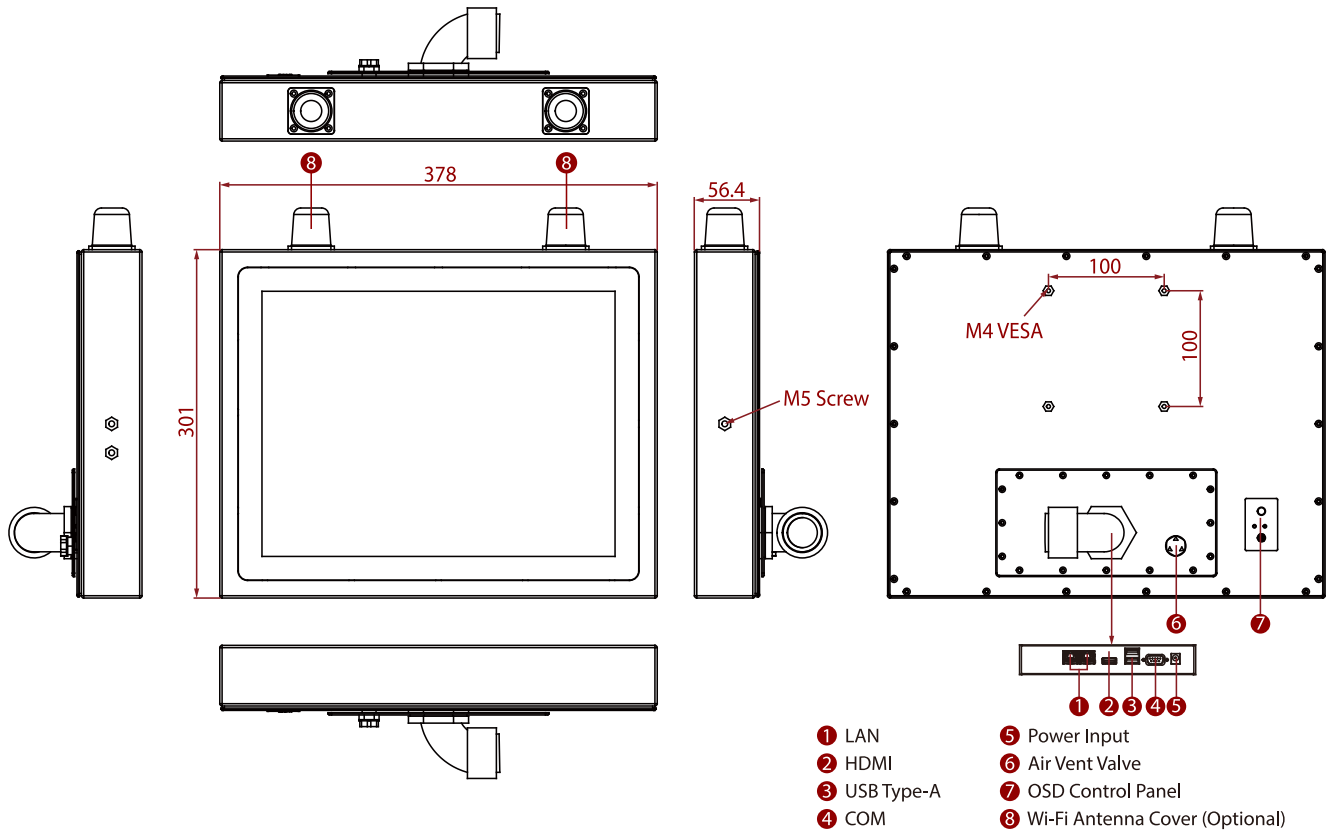

## NOTE

1. The yoke mount stand kit is an optional accessory.
2. Wi-Fi antenna is an optional feature.
3. The product shown in this datasheet is a standard model. For diagrams that contain customized or optional I/O, please contact the Winmate Sales Team for more information.