

IP65 Stainless Resistive

15"/ 17"/ 19"/ 21.5"/ 23.8" Panel PC

8th Generation (Whiskey Lake) Intel® Core™ i5-8265U 1.6GHz (turbo to 3.9GHz)

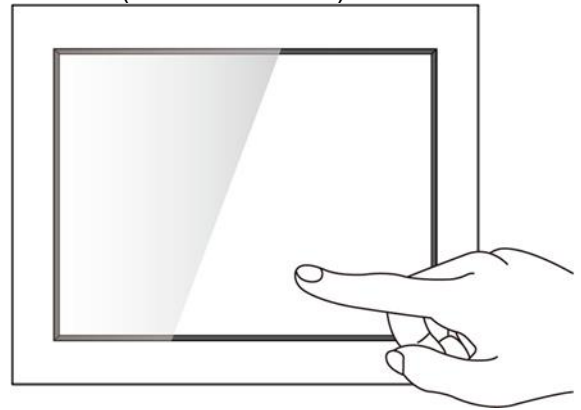

Model No. R15IW3S-65C3
R17IW3S-65M1
R19IW3S-65M1
W22IW3S-65A3
W24IW3S-65A2

Quick Start Guide

Contents

Chapter 1: Introduction	6
1.1 Features	6
1.2 Package Content	7
1.3 Product Overview	8
1.3.1 Dimensions 15"	8
1.3.2 Dimensions 17"	8
1.3.3 Dimensions 19"	9
1.3.4 Dimensions 21.5"	9
1.3.5 Dimensions 23.8"	10
1.4 Physical Buttons and LED Indicators	11
1.5 Connectors	11
2.1 Wiring Requirements	12
2.2 Connector Pin Assignments	12
2.2.1 Power Cable	12
2.2.2 Serial Cable	13
2.2.3 Ethernet Cable	13
2.2.4 USB 2.0 Cable	14
2.3 Mounting	14
2.3.1 VESA Mount	14
2.3.2 Yoke Mount	15
Chapter 3: Getting Started	16
3.1 Turning On and Off Your Device	16
3.2 How to Enable Watchdog	17
Appendix	18
Appendix A: Hardware Specifications	18
Appendix B: Winmate Software Development Kit	20
Appendix C: Cleaning the Monitor	21

FCC Statement



This device complies with part 15 FCC rules.

Operation is subject to the following two conditions:

- This device may not cause harmful interference.
- This device must accept any interference received including interference that may cause undesired operation.

This equipment has been tested and found to comply with the limits for a class "B" digital device, pursuant to part 15 of the FCC rules. These limits are designed to provide reasonable protection against harmful interference when the equipment is operated in a commercial environment. This equipment generates, uses, and can radiate radio frequency energy and, if not installed and used in accordance with the instruction manual, may cause harmful interference to radio communications. Operation of this equipment in a residential area is likely to cause harmful interference in which case the user will be required to correct the interference at his own expense.

European Union



Electromagnetic Compatibility Directive (2014/30/EU)

- EN55024: 2010/ A1: 2015
 - IEC61000-4-2: 2009
 - IEC61000-4-3: 2006+A1: 2007+A2: 2010
 - IEC61000-4-4: 2012
 - IEC61000-4-5: 2014
 - IEC61000-4-6: 2014
 - IEC61000-4-8: 2010
 - IEC61000-4-11: 2004
- EN55032: 2012/AC:2013
- EN61000-3-2:2014
- EN61000-3-3:2013

Low Voltage Directive (2014/35/EU)

- EN 60950-1:2006/A11:2009/A1:2010/A12:2011/ A2:2013

This equipment is in conformity with the requirement of the following EU legislations and harmonized standards. Product also complies with the Council directions.

Copyright Notice

No part of this document may be reproduced, copied, translated, or transmitted in any form or by any means, electronic or mechanical, for any purpose, without the prior written permission of the original manufacturer.

Trademark Acknowledgement

Brand and product names are trademarks or registered trademarks of their respective owners.

Disclaimer

Winmate Inc. reserve the right to make changes, without notice, to any product, including circuits and/or software described or contained in this manual in order to improve design and/or performance. We assume no responsibility or liability for the use of the described product(s) conveys no license or title under any patent, copyright, or masks work rights to these products, and make no representations or warranties that these products are free from patent, copyright, or mask work right infringement, unless otherwise specified. Applications that are described in this manual are for illustration purposes only. We make no representation or guarantee that such application will be suitable for the specified use without further testing or modification.

Warranty

Winmate Inc. warranty guarantees that each of its products will be free from material and workmanship defects for a period of one year from the invoice date. If the customer discovers a defect, we will, at his/her option, repair or replace the defective product at no charge to the customer, provide it is returned during the warranty period of one year, with transportation charges prepaid. The returned product must be properly packaged in its original packaging to obtain warranty service. If the serial number and the product shipping data differ by over 30 days, the in-warranty service will be made according to the shipping date. In the serial numbers the third and fourth two digits give the year of manufacture, and the fifth digit means the month (e. g., with A for October, B for November and C for December).

For example, the serial number 1W17Axxxxxxx means October of year 2017.

Customer Service

We provide a service guide for any problem by the following steps: First, visit the website of our distributor to find the update information about the product. Second, contact with your distributor, sales representative, or our customer service center for technical support if you need additional assistance.

You may need the following information ready before you call:

- Product serial number
- Software (OS, version, application software, etc.)
- Description of complete problem
- The exact wording of any error messages

In addition, free technical support is available from our engineers every business day. We are always ready to give advice on application requirements or specific information on the installation and operation of any of our products.

Advisory Conventions

Four types of advisories are used throughout the user manual to provide helpful information or to alert you to the potential for hardware damage or personal injury. These are Notes, Important, Cautions, and Warnings. The following is an example of each type of advisory.



Note:

A note is used to emphasize helpful information



Important:

An important note indicates information that is important for you to know.



Caution A Caution alert indicates potential damage to hardware and explains how to avoid the potential problem.

Attention Une alerte d'attention indique un dommage possible à l'équipement et explique comment éviter le problème potentiel.



Warning! An Electrical Shock Warning indicates the potential harm from electrical hazards and how to avoid the potential problem.

Avertissement! Un Avertissement de Choc Électrique indique le potentiel de chocs sur des emplacements électriques et comment éviter ces problèmes.



Earth Ground! The Protective Conductor Terminal (Earth Ground) symbol indicates the potential risk of serious electrical shock due to improper grounding.

Mise à le terre ! Le symbole de Mise à Terre indique le risqué potentiel de choc électrique grave à la terre incorrecte.

Safety Information

Warning! Always completely disconnect the power cord from your chassis whenever you work with the hardware. Do not make connections while the power is on. Sensitive electronic components can be damaged by sudden power surges. Only experienced electronics personnel should open the PC chassis.



Avertissement! Toujours débrancher le cordon d'alimentation du chassis lorsque vous travaillez sur celui-ci. Ne pas brancher de connexions lorsque l'alimentation est présente. Des composants électroniques sensibles peuvent être endommagés par des sauts d'alimentation. Seulement du personnel expérimenté devrait ouvrir ces chassis.

Caution Always ground yourself to remove any static charge before touching the CPU card. Modern electronic devices are very sensitive to static electric charges. As a safety precaution, use a grounding wrist strap at all times. Place all electronic components in a static-dissipative surface or static-shielded bag when they are not in the chassis.



Attention Toujours vérifier votre mise à la terre afin d'éliminer toute charge statique avant de toucher la carte CPU. Les équipements électroniques modernes sont très sensibles aux décharges d'électricité statique. Toujours utiliser un bracelet de mise à la terre comme précaution. Placer toutes les composantes électroniques sur une surface conçue pour dissiper les charge, ou dans un sac anti-statique lorsqu'elles ne sont pas dans le chassis.

Chapter 1: Introduction

Congratulations on purchasing Winmate® IP65 Stainless Resistive Panel PC.

Winmate flat stainless steel PCAP panel PCs and display are designed for applications with high hygienic requirements. IP65 series is completely waterproof with IP65 level of protection. The IP65 stainless series work well in food, beverage industry, including food processing operations and packaging, chemical manufacturing and other industrial applications.

1.1 Features

The IP65 Stainless Resistive Panel PC features:

- 8th Generation (Whiskey Lake) Intel® Core™ i58265U 1.6GHz (turbo to 3.9GHz)
- SUS316 stainless steel for food and chemical industries
- 5 Wire resistive touch, anti-reflective protection glass (Optional)
- Full IP65 waterproof enclosure
- Various mounting solutions, Yoke mount and VESA mount
- Plenty of I/O s including USB 2.0, RS-232 serial port and RJ45 LAN ports
- Waterproof ports with adapter cables for external connectivity
- Supports VESA mount

1.2 Package Content

Carefully remove the box and unpack your device. Please check if all the items listed below are inside your package. If any of these items are missing or damaged contact us immediately.

Standard shipment list:

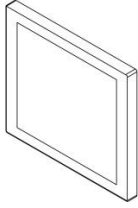

- **Panel PC**



- **Quick Start Guide (Hardcopy)**



- **Driver CD & User Manual**

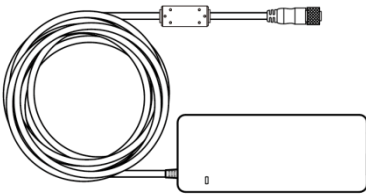

- **AC Adapter**

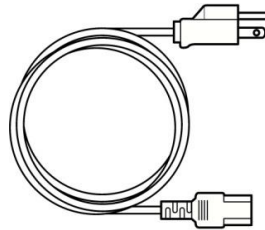

- **Power Cable***

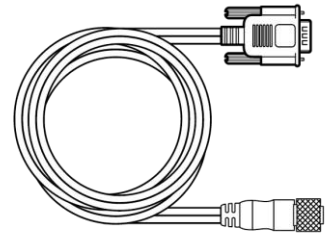

- **Serial Cable**

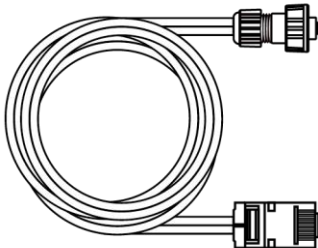

- **Ethernet Cable**

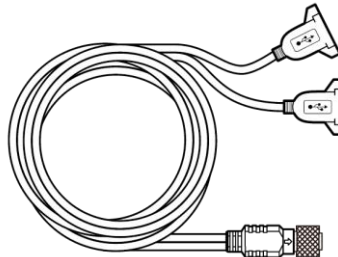

- **USB Cable**

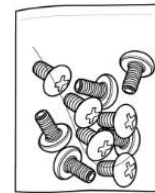

- **VESA Screws**

1.3 Product Overview

This section contains mechanical drawing of the Panel PC. Notice that this is a simplified drawing and some components are not marked in detail.

1.3.1 Dimensions 15"

Unit: mm

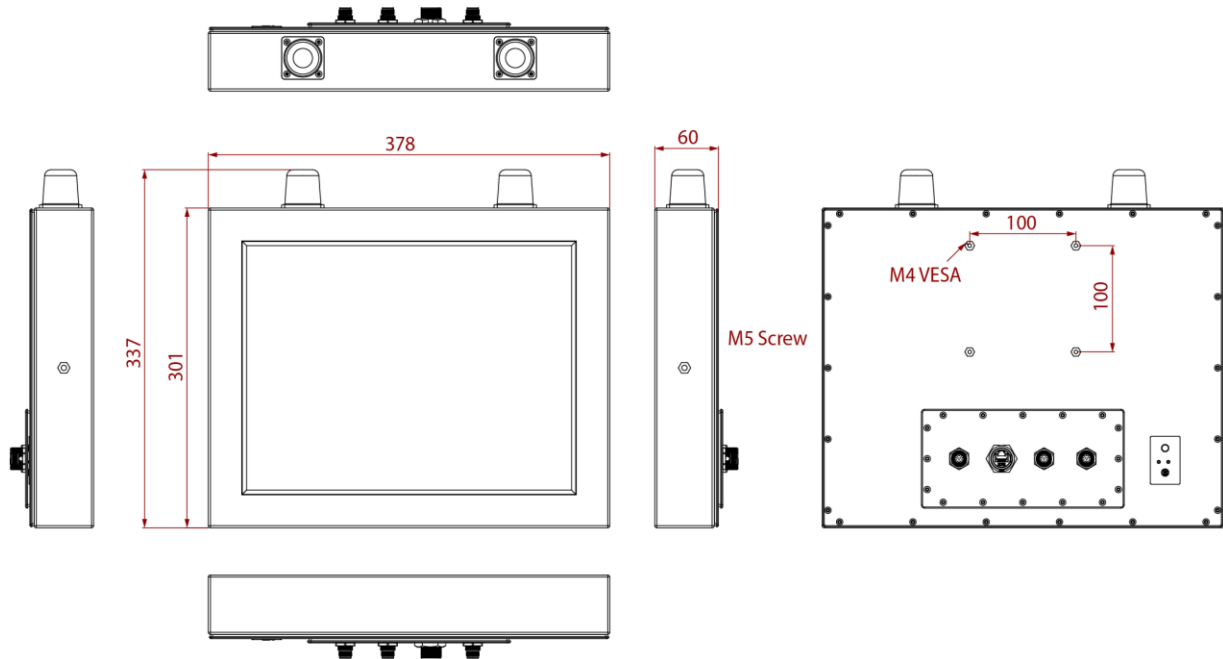

1.3.2 Dimensions 17"

Unit: mm

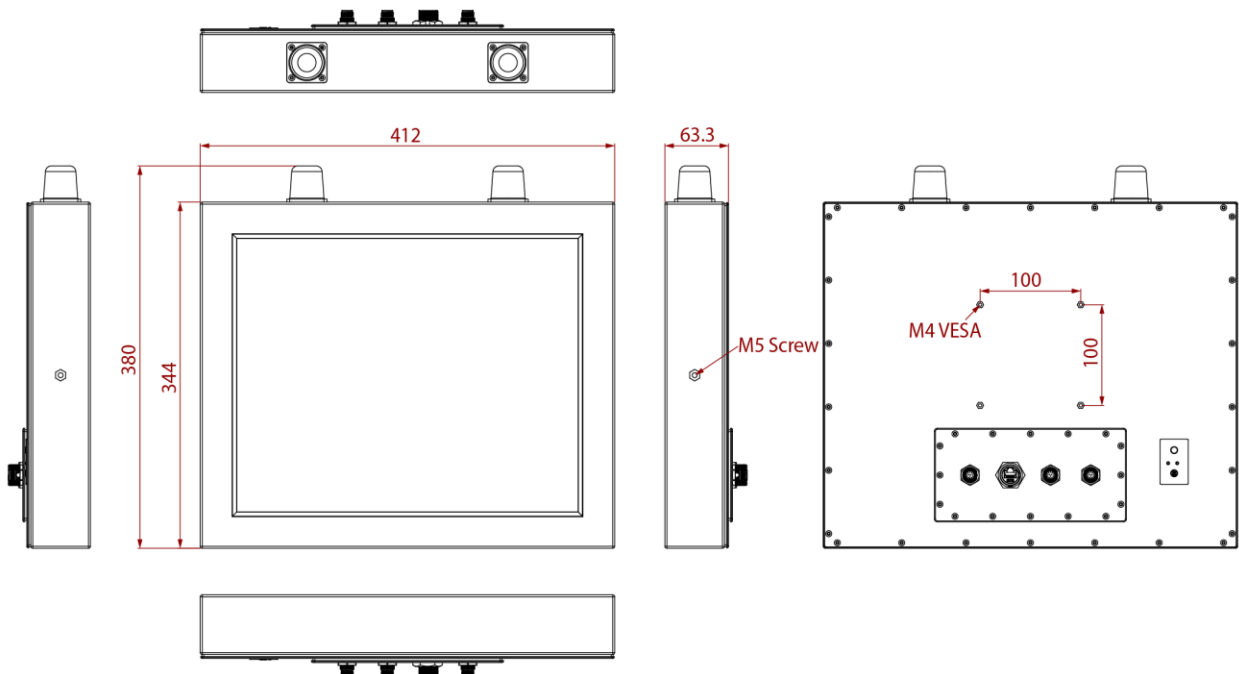

1.3.3 Dimensions 19"

Unit: mm

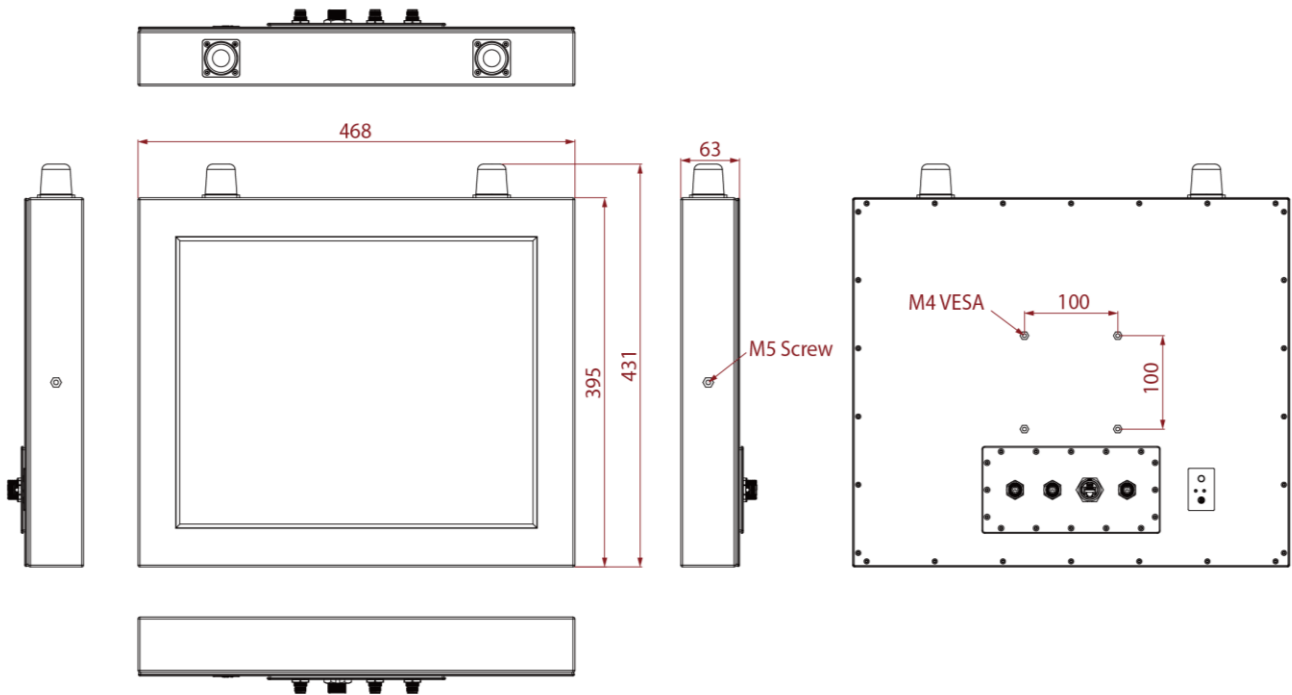

1.3.4 Dimensions 21.5"

Unit: mm

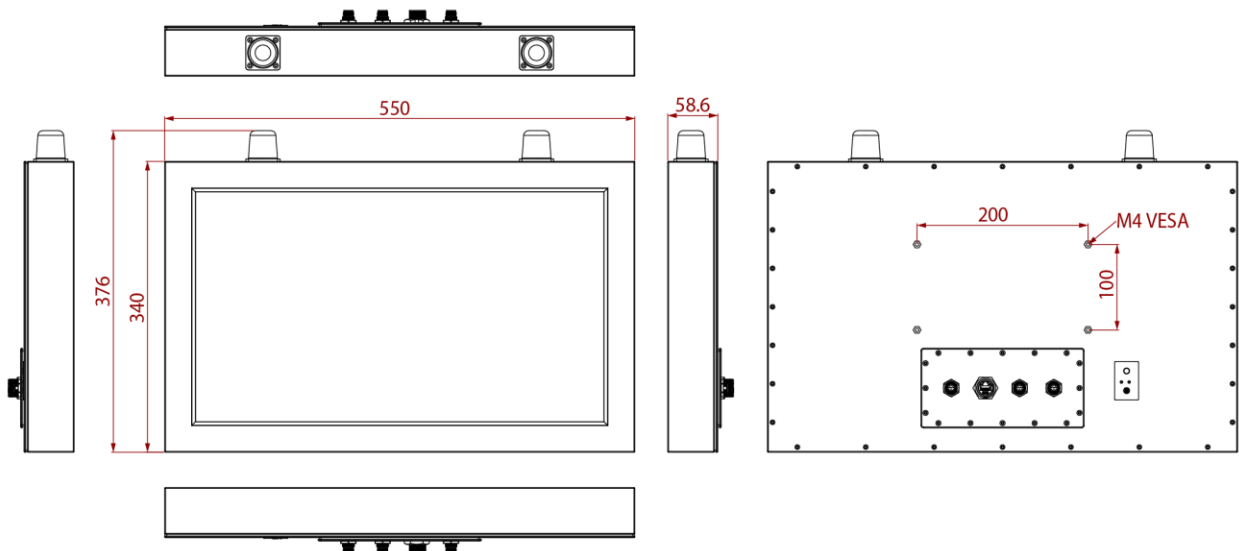

1.3.5 Dimensions 23.8"

Unit: mm

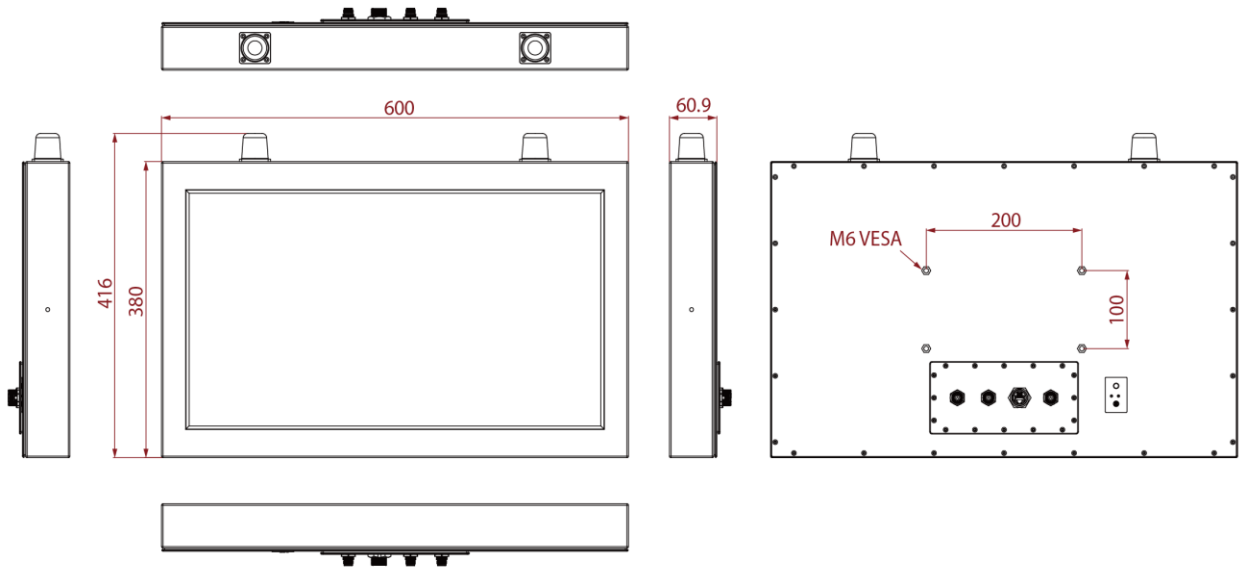



1.4 Physical Buttons and LED Indicators

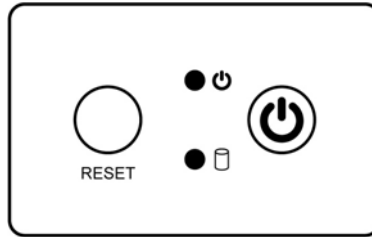

Physical buttons and LED indicators located on the rear side of the Panel PC.



Physical Buttons

Icon	Button	Description
	Reset	Press to reset the system
	Power On/ Off	Press to power on or power off the device

LED Indicators

LED Type	Status	Description
	On	Power is on
	Off	Power is off
	Blinking	Storage activity (Data is being read or written)
	Off	System is idle

1.5 Connectors

IP65 Stainless Resistive Panel PC has waterproof connectors with protection caps.

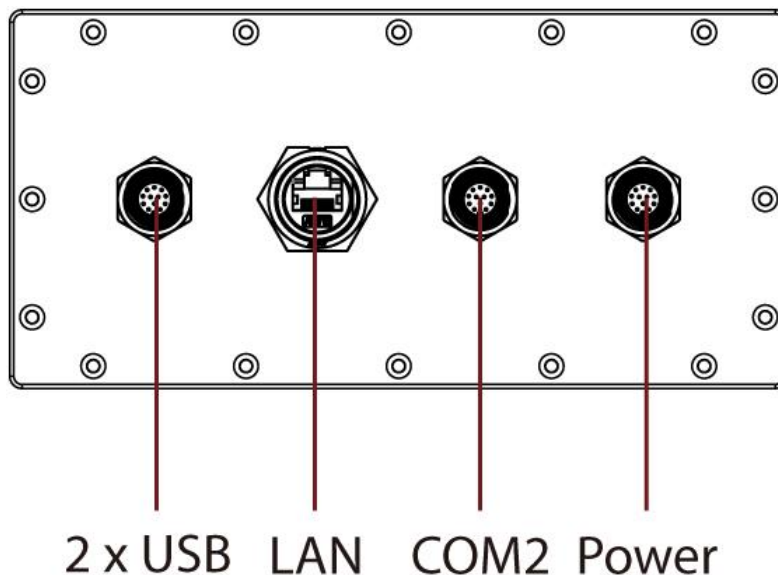

Chapter 2: Hardware Installation

2.1 Wiring Requirements

The following safety precautions should be observed before installing any electronic device:

- Strive to use separate, non-intersecting paths to route power and networking wires. If power wiring and device wiring paths must cross make sure the wires are perpendicular at the intersection point.
- Keep the wires separated according to interface. The rule of thumb is that wiring that shares similar electrical characteristics may be bundled together.
- Do not bundle input wiring with output wiring. Keep them separate.
- When necessary, it is strongly advised that you label wiring to all devices in the system.
- Do not run signal or communication wiring and power wiring in the same conduit. To avoid interference, wires with different signal characteristics (i.e., different interfaces) should be routed separately.
- Be sure to disconnect the power cord before installing and/or wiring your device.
- Verify the maximum possible current for each wire gauge, especially for the power cords. Observe all electrical codes dictating the maximum current allowable for each wire gauge.
- If the current goes above the maximum ratings, the wiring could overheat, causing serious damage to your equipment.
- Be careful when handling the unit. When the unit is plugged in, the internal components generate a lot of heat which may leave the outer casing too hot to touch.

2.2 Connector Pin Assignments

This Panel PC is equipped with four waterproof I/O connectors. Use only the cables that are included in the package. The pin assignments of the cables are as follows.

2.2.1 Power Cable

The IP65 Stainless Resistive Panel PC has one waterproof I/O power input connector. Use power cable to connect Panel PC to the source of power. IP65 Stainless Resistive Panel PC support 12V DC power input.

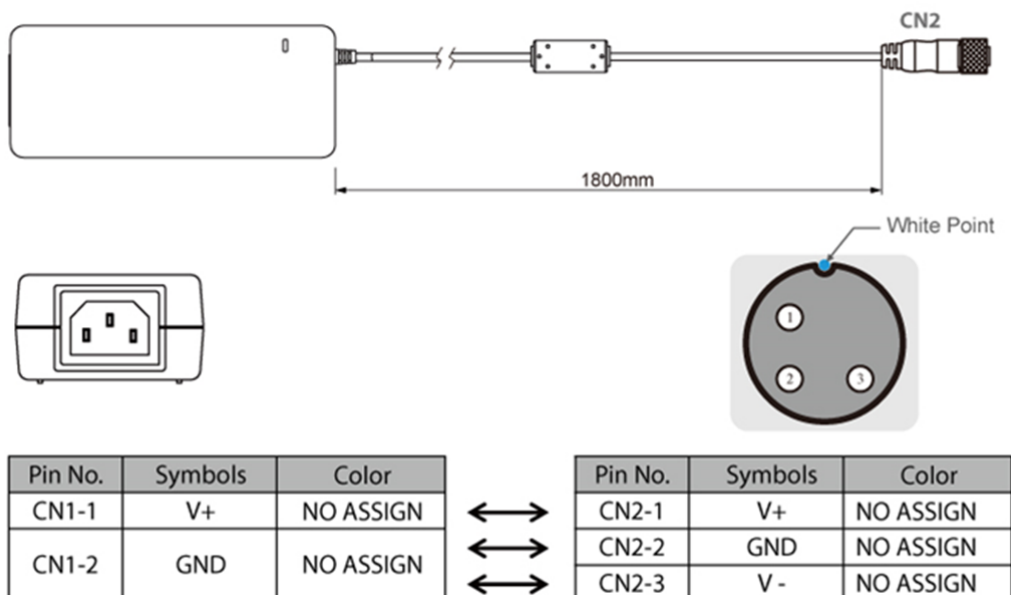

2.2.2 Serial Cable

The IP65 Stainless Resistive Panel PC has one waterproof serial port connector. Use serial cable to connect serial interfaces.

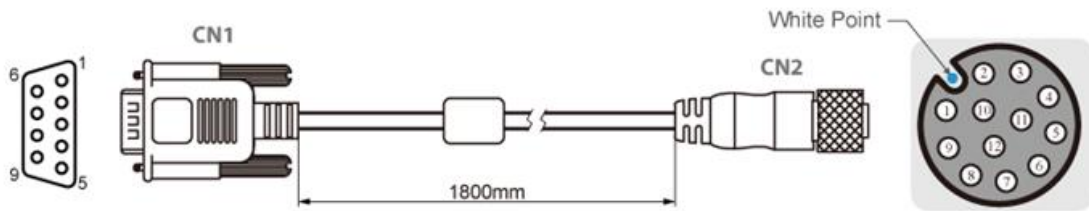

Pin No.	Symbols	Color		Pin No.	Symbols	Color
CN1-1	DCD-CON2	Green	↔	CN2-1	DCD-CON2	Green
CN1-6	DSR-CON2	Brown	↔	CN2-2	DSR-CON2	Brown
CN1-2	RXD-CON2	Red	↔	CN2-3	RXD-CON2	Red
CN1-7	RTS-CON2	Orange	↔	CN2-4	RTS-CON2	Orange
CN1-3	TXD-CON2	Blue	↔	CN2-5	TXD-CON2	Blue
CN1-8	CTS-CON2	White	↔	CN2-6	CTS-CON2	White
CN1-4	DTR-CON2	Purple	↔	CN2-7	DTR-CON2	Purple
CN1-9	RI-CON2	Yellow	↔	CN2-8	RI-CON2	Yellow
CN1-5	GND-CON2	Black	↔	CN2-9	GND-CON2	Black

2.2.3 Ethernet Cable

The IP65 Stainless Resistive Panel PC has one waterproof Ethernet connector. Use Ethernet cable to connect the Panel PC to the Internet.

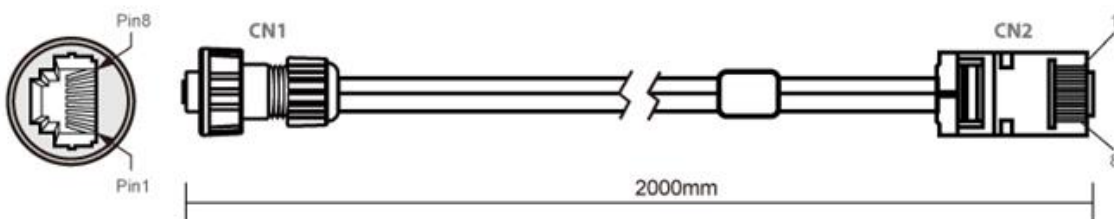

Plug	Wire Color	Conn.	
1	Orange / White	1	Twist
2	Orange	2	
3	Green / White	3	Twist
4	Blue	4	
5	Blue / White	5	
6	Green	6	Twist
7	Brown / White	7	
8	Brown	8	

2.2.4 USB 2.0 Cable

The IP65 Stainless Resistive Panel PC has one waterproof USB 2.0 connector. Use USB 2.0 cable to connect external devices such as mouse or keyboard to the Panel PC.

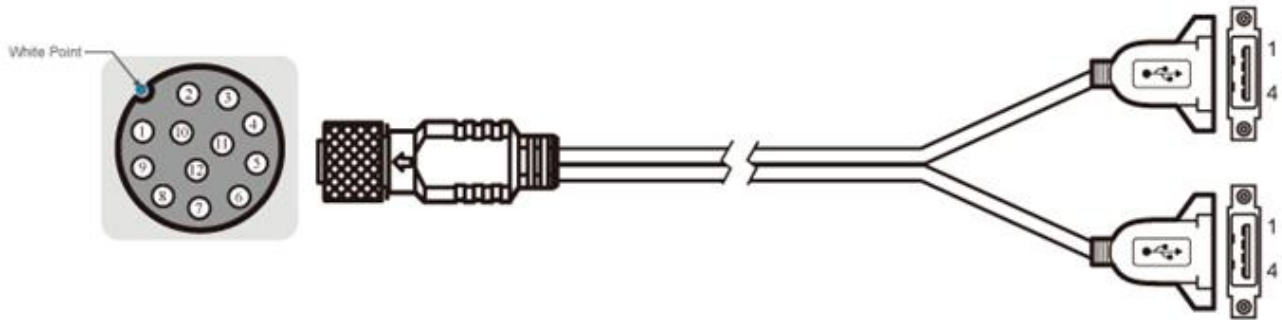

Pin No.	Symbols	Color		Pin No.	Symbols	Color	
CN1-2	VCC	RED	↔	CN2-1	VCC	RED	twisted pair
CN1-3	D-	WHITE	↔	CN2-2	D-	WHITE	
CN1-4	D+	GREEN	↔	CN2-3	D+	GREEN	
CN1-5	GND	BLACK	↔	CN2-4	GND	BLACK	
CN1-6	VCC	RED	↔	CN3-1	VCC	RED	twisted pair
CN1-7	D-	WHITE	↔	CN3-2	D-	WHITE	
CN1-8	D+	GREEN	↔	CN3-3	D+	GREEN	
CN1-9	GND	BLACK	↔	CN3-4	GND	BLACK	
CN1-1	GND	Braid	↔	Braid 接鐵殼			

2.3 Mounting

The IP65 Stainless Resistive Panel PC devices come with different mounting options suitable for most of the industrial and commercial applications.

2.3.1 VESA Mount

The Panel PC has VESA mount holes on the rear side. Follow instructions below to mount the unit with VESA Mount bracket (not supplied by Winmate).

Size	VESA Plate Dimensions	Screw Hole Diameter
15", 17, 19"	100 x 100 mm	VESA M4x5 mm
21.5"	100 x 200 mm	VESA M4x5 mm
23.8"	100 x 200 mm	VESA M6x8 mm

Mounting Instruction:

1. Screw VESA bracket to the fixture (ex. swing arm) with four VESA screws.
2. Place the device on VESA bracket.

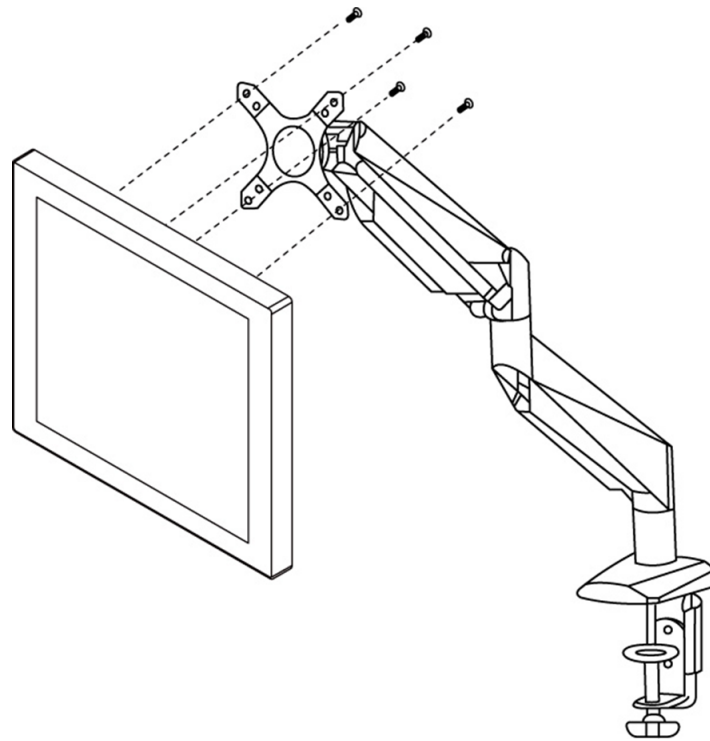

2.3.2 Yoke Mount

Yoke Mount solution allows installing the Panel PC with the bracket (not supplied by Winmate).

Mounting instruction:

1. Place the Panel PC on the bracket stand, aiming screw holes for each other.
2. Secure screws to fix the device upon the bracket stand.
3. Firmly secure the locking handle to the Panel PC.

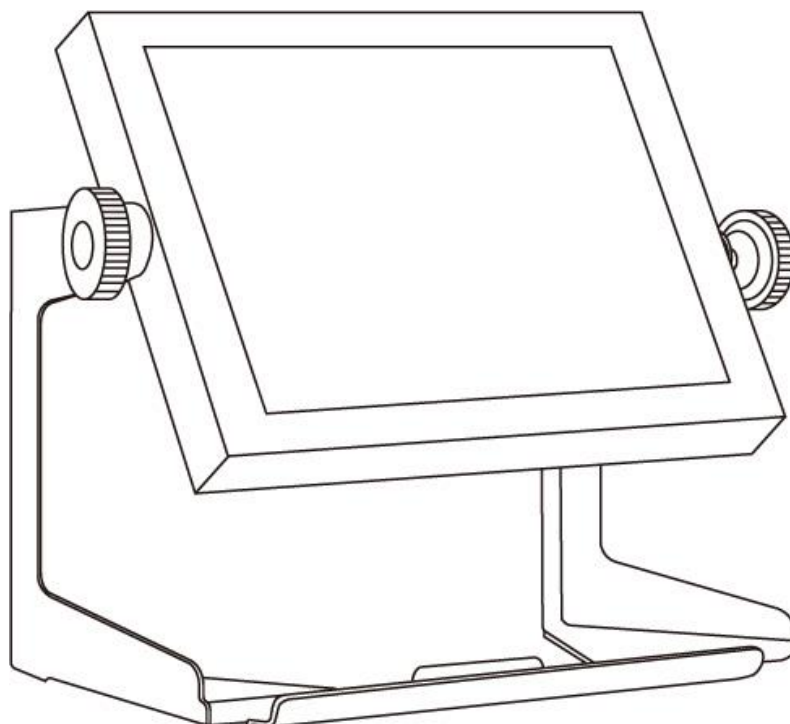

Chapter 3: Getting Started

3.1 Turning On and Off Your Device

To turn on your device:

1. Connect the AC adapter to the DC-in jack connector located on the back side of the Panel PC.
2. Connect the power cord to AC adapter.
3. Plug the power cord to the AC outlet and the device will turn on automatically.

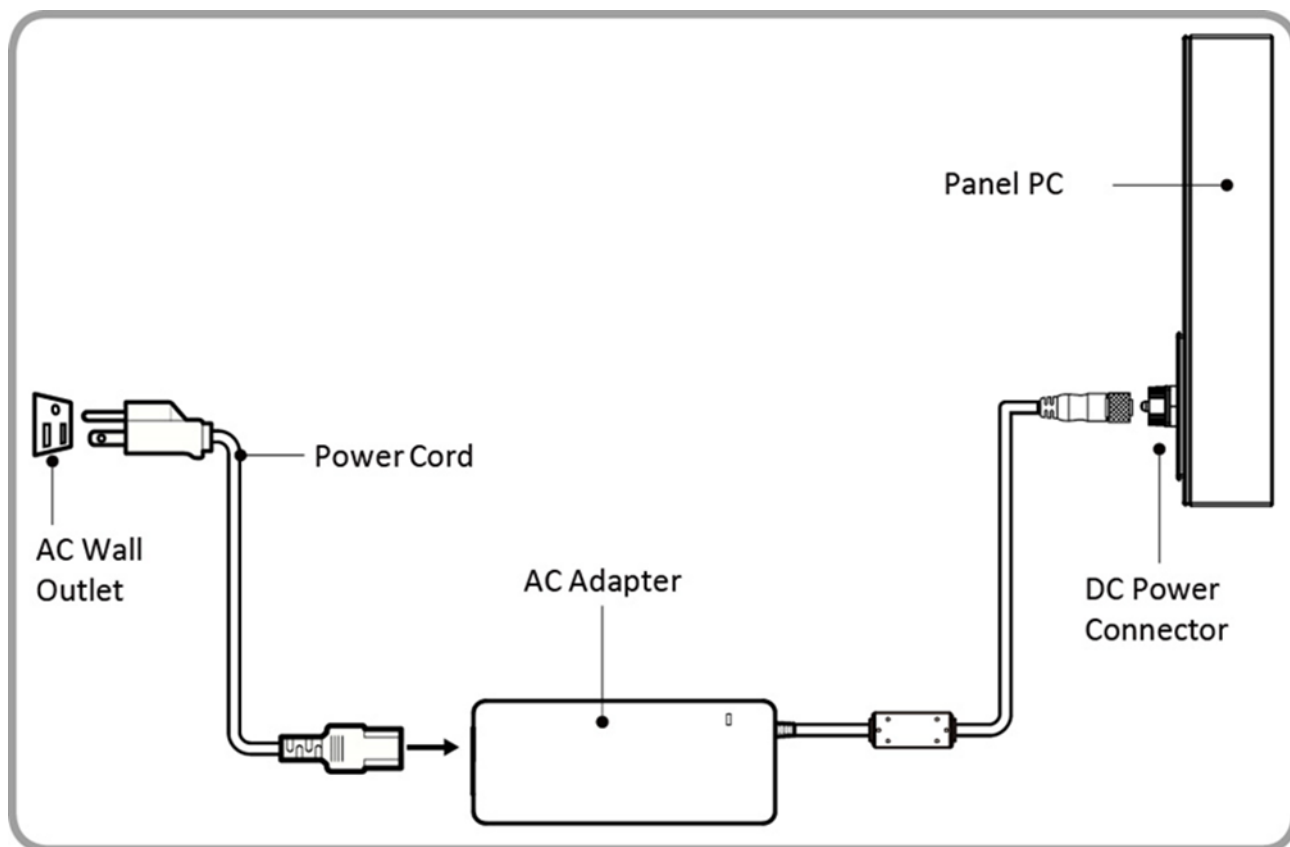

AC Adapter specifications vary by panel size.

Size	15"	17"	19"	21.5"	23.8"
AC Adapter	12V/ 80W	12V/ 80W	12V/ 80W	12V/ 80W	12V/ 80W
Power Consumption*	52W (typ.)	56W (typ.)	56W (typ.)	66W (typ.)	66W (typ.)

*With maximum backlight and high CPU load.

To turn off your device:



To shut down your device, do the following: Tap Start () > Shut down.

Wait for your Panel PC to completely turn off before disconnecting the power cord (if necessary).

3.2 How to Enable Watchdog

To enable Watchdog, you need to download Winmate Watchdog utility. Find more information on Watchdog in “Watchdog Guide” that you can download from Winmate Download Center or File Share. Refer to the User Manual for more details.

To enable watchdog in Watchdog AP follow the instructions below:

1. On the right bottom side of the desktop screen, click  **triangle button** to show hidden icons.
2. Click  icon to open Watchdog utility.

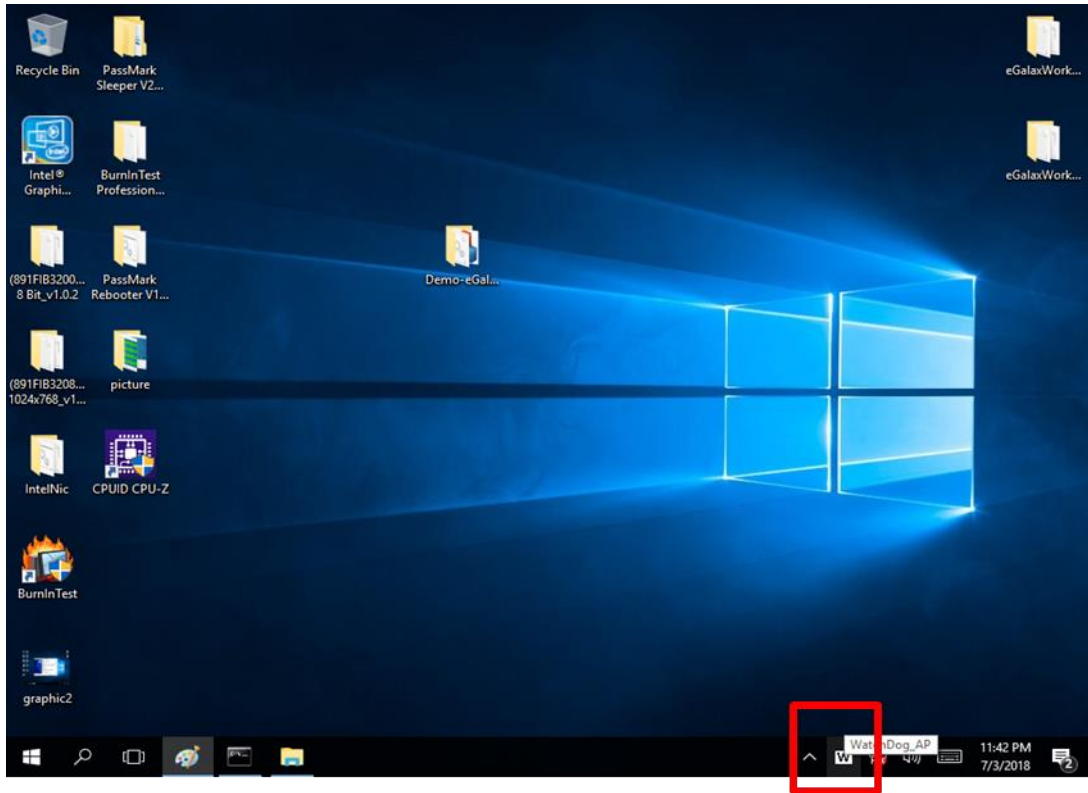

3. In Watchdog utility window set countdown time and periodically feed time, or disable watchdog.

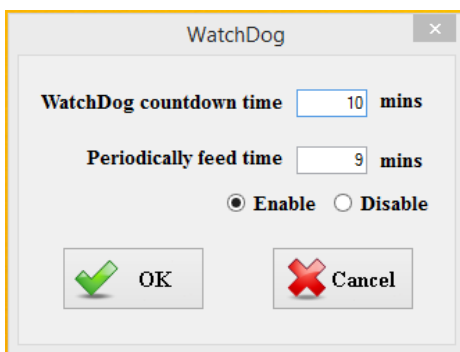

Example:

Every 10 min watchdog will monitor the system, in case any error occurs the system will restart automatically when the countdown time reaches 0.

Every 9 min watchdog timer will be reset to 10 min.

Setting	Description
Watchdog Countdown Time	The system automaticity restarts when this countdown time reaches zero. <i>Default: 10 min</i>
Periodically Feed Time	To set a cycle time to automatically reset watchdog timer. <i>Default: 9 min</i>
Enable / Disable	Enable or disable watchdog. <i>Default: Enable</i>

Appendix

Appendix A: Hardware Specifications

	Model Name				
	R15IW3S-65C3	R17IW3S-65M1	R19IW3S-65M1	W22IW3S-65A3	W24IW3S-65A2
Display					
Size	15"	17"	19"	21.5"	23.8"
Resolution	1024 x 768	1280 x 1024	1280 x 1024	1920 x 1080	1920 x 1080
Panel Brightness	300 nits	350 nits	250 nits	250 nits	250 nits
Contrast Ratio	2000 : 1	1000 : 1 (typ.)	1000 : 1 (typ.)	3000 : 1(typ.)	3000 : 1(typ.)
Viewing Angle	88,88,88,88	85,85,80,80	85,85,80,80	89,89,89,89	89,89,89,89
Touch	Resistive Touch Screen, Protection Glass w/o Touch Function (Optional)	Resistive Touch Screen, Protection Glass w/o Touch Function (Optional)	Resistive Touch Screen, Protection Glass w/o Touch Function (Optional)	Resistive Touch Screen, Protection Glass w/o Touch Function (Optional)	Resistive Touch Screen, Protection Glass w/o Touch Function (Optional)
System Specification					
Processor	Intel® Core™ i5 8265U (6M Cache, 1.6GHz up to 3.9 GHz)	Intel® Core™ i5 8265U (6M Cache, 1.6GHz up to 3.9 GHz)	Intel® Core™ i5 8265U (6M Cache, 1.6GHz up to 3.9 GHz)	Intel® Core™ i5 8265U (6M Cache, 1.6GHz up to 3.9 GHz)	Intel® Core™ i5 8265U (6M Cache, 1.6GHz up to 3.9 GHz)
System Memory	1 x SODIMM, DDR4 2400 MHz, 4GB 8GB (Optional) 16GB (Optional) 32GB (Optional)	1 x SODIMM, DDR4 2400 MHz, 4GB 8GB (Optional) 16GB (Optional) 32GB (Optional)	1 x SODIMM, DDR4 2400 MHz, 4GB 8GB (Optional) 16GB (Optional) 32GB (Optional)	1 x SODIMM, DDR4 2400 MHz, 4GB 8GB (Optional) 16GB (Optional) 32GB (Optional)	1 x SODIMM, DDR4 2400 MHz, 4GB 8GB (Optional) 16GB (Optional) 32GB (Optional)
Storage	1 x M.2 2242 Bkey SSD 64GB M.2 2242 Bkey SSD up to 512GB (Optional) M.2 2280 NVME SSD, up to 4TB (Optional)	1 x M.2 2242 Bkey SSD 64GB M.2 2242 Bkey SSD up to 512GB (Optional) M.2 2280 NVME SSD, up to 4TB (Optional)	1 x M.2 2242 Bkey SSD 64GB M.2 2242 Bkey SSD up to 512GB (Optional) M.2 2280 NVME SSD, up to 4TB (Optional)	1 x M.2 2242 Bkey SSD 64GB M.2 2242 Bkey SSD up to 512GB (Optional) M.2 2280 NVME SSD, up to 4TB (Optional)	1 x M.2 2242 Bkey SSD 64GB M.2 2242 Bkey SSD up to 512GB (Optional) M.2 2280 NVME SSD, up to 4TB (Optional)
Ethernet	Intel® Ethernet Controller I210AT + Intel® Ethernet Connection I219LM	Intel® Ethernet Controller I210AT + Intel® Ethernet Connection I219LM	Intel® Ethernet Controller I210AT + Intel® Ethernet Connection I219LM	Intel® Ethernet Controller I210AT + Intel® Ethernet Connection I219LM	Intel® Ethernet Controller I210AT + Intel® Ethernet Connection I219LM
OS	Windows 10 IoT Enterprise (Optional) Linux Ubuntu 18.04 (Optional)	Windows 10 IoT Enterprise (Optional) Linux Ubuntu 18.04 (Optional)	Windows 10 IoT Enterprise (Optional) Linux Ubuntu 18.04 (Optional)	Windows 10 IoT Enterprise (Optional) Linux Ubuntu 18.04 (Optional)	Windows 10 IoT Enterprise (Optional) Linux Ubuntu 18.04 (Optional)

	Model Name				
	R15IW3S-65C3	R17IW3S-65A1	R19IW3S-65M1	W22IW3S-65A3	W24IW3S-65A2
Interfaces					
Ethernet LAN	1 x Waterproof Giga LAN RJ45 Connector	1 x Waterproof Giga LAN RJ45 Connector	1 x Waterproof Giga LAN RJ45 Connector	1 x Waterproof Giga LAN RJ45 Connector	1 x Waterproof Giga LAN RJ45 Connector
Serial Port	1 x M12 waterproof connector for RS232	1 x M12 waterproof connector for RS232	1 x M12 waterproof connector for RS232	1 x M12 waterproof connector for RS232	1 x M12 waterproof connector for RS232
USB	1x M12 Waterproof Connector for 2 x USB2.0	1x M12 Waterproof Connector for 2 x USB2.0	1x M12 Waterproof Connector for 2 x USB2.0	1x M12 Waterproof Connector for 2 x USB2.0	1x M12 Waterproof Connector for 2 x USB2.0
Indicator	1 x LED Indicator for power 1 x LED Indicator for storage	1 x LED Indicator for power 1 x LED Indicator for storage	1 x LED Indicator for power 1 x LED Indicator for storage	1 x LED Indicator for power 1 x LED Indicator for storage	1 x LED Indicator for power 1 x LED Indicator for storage
Mechanical Specification					
Enclosure	Stainless Housing	Stainless Housing	Stainless Housing	Stainless Housing	Stainless Housing
Cooling System	Fanless	Fanless	Fanless	Fanless	Fanless
Mounting	VESA Mount, Yoke Mount,	VESA Mount, Yoke Mount,	VESA Mount, Yoke Mount,	VESA Mount, Yoke Mount,	VESA Mount, Yoke Mount,
Environmental Consideration					
Operating Temp.	0°C to +45°C	0°C to +45°C	0°C to +45°C	0°C to +45°C	0°C to +45°C
Operating Humidity	10% to 90% (non-condensing)	10% to 90% (non-condensing)	10% to 90% (non-condensing)	10% to 90% (non-condensing)	10% to 90% (non-condensing)
IP Rating	IP65	IP65	IP65	IP65	IP65
Power Specifications					
Power Rating	12V DC (M12 type)	12V DC (M12 type)	12V DC (M12 type)	12V DC (M12 type)	12V DC (M12 type)
Standards and Certification					
Certification	CE, FCC	CE, FCC	CE, FCC	CE, FCC	CE, FCC

Appendix B: Winmate Software Development Kit

Wimate provides the following SDK and Utilities for the IP65 Stainless Resistive Panel PC.

Item	File Type	Description
1	SDK	Watchdog SDK
2	Utility	Watchdog Utility

To find the Drivers and SDK, please refer to the Driver CD that comes in the package or contact us. Also, you can download drivers from Winmate Download Center.

Wimate Download Center

Wimate's official website www.wimate.com > Support > Download Center

Appendix C: Cleaning the Monitor

Before cleaning:

- Make sure the device is turned off.
- Disconnect the power cable from any AC outlet.

When cleaning:

- Use water up to 80°C to clean the housing.
- Wipe the screen with a clean, soft, lint-free cloth. This removes dust and other particles.
- The display area is highly prone to scratching. Do not use ketene type material (ex. Acetone), Ethyl alcohol, toluene, ethyl acid or Methyl chloride to clear the panel. It may permanently damage the panel and void the warranty.
- If it is still not clean enough, apply a small amount of non-ammonia, non-alcohol based glass cleaner onto a clean, soft, lint-free cloth, and wipe the screen.
- Do not use oil directly on the display screen. If droplets are allowed to drop on the screen, permanent staining or discoloration may occur.

Winmate Inc.
9F, No.111-6, Shing-De Rd., San-Chung District,
New Taipei City 24158, Taiwan, R.O.C
www.winmate.com

