

M900P

8 inch Windows Tablet, Intel® Pentium® N4200



KEY FEATURES

- Intel® Pentium® N4200 Apollo Lake processor, 8" Windows Rugged Tablet
- 8" 1280 x 800 IPS LED Panel with direct optical bonding
- Projected Capacitive (P-Cap) multitouch
- Default D-sub for vehicle gateway connection
- USB 3.0 Type A, USB 3.0 Type C connectors
- IP65 waterproof and dustproof



SPECIFICATIONS

Display			
Resolution	1280x800	Size	8 inches
Contrast Ratio	800:1	Panel Brightness	510 nits
View Angles	85,85,85,85	Type	Projected Capacitive Multi Touch
Bonding	Optical Bonding for Sunlight Viewability		
System Specification			
Processor	Intel Pentium N4200 1.1GHz (up to 2.5GHz)	Memory	4GB LPDDR4 8GB LPDDR4 (Optional)
Storage	128GB SSD Additional storage available with micro SDXC card slot 256GB SSD (Optional) 512GB SSD (Optional)	Security	Trusted Platform Module (TPM) 2.0
Operating System	Windows 10 IoT Enterprise (64 bit)	WLAN	Support
BT	Support	WWAN	4G LTE (Optional)
GNSS	GPS, GLONASS	RFID	Mutually Exclusive with Barcode Reader HF RFID Reader 13.56 MHz (Optional) LF RFID Reader 125 KHz (Optional)
Sensors	Light sensor/ G-sensor / Gyro	Smart Card Reader	Smart Card Reader Comply with ISO7816-1.2.3 T=1 and T=Ø protocol (Optional)
Camera			
Front Camera	2MP Front Camera	Rear Camera	8MP Rear Camera with Autofocus and LED Light
Mechanical			
Dimension	225 x 148 x 20.5 mm (10 x 7.76 x 0.8 inches)	Weight	0.9 kg with battery
Cooling System	Fanless design		
IO Ports			
USB Port	1 x USB 3.0 (Type A), 1 x USB 3.0 (Type C)	SD Card Slot	1 x Micro SDXC Slot
SIM Card Slot	1 x Micro SIM card slot	Audio	1 x Audio combo 3.5mm audio combo jack Dual Digital Mic With Noise Cancellation Dual Speaker
Expansion Port	1 x 15-pin D-sub connector for Power Input, USB 2.0, Audio Out, and Tx/ Rx	Indicator	4x LED Indicator for Power, Battery, HDD, RF status

Docking Connector 1 x 19-pin docking connector

Environment

Operating Humidity	10% to 90% RH, non-condensing	Operating Temperature	-20°C to 60°C (AC mode), -10°C to 50°C (Battery mode)
Storage Temperature	-30°C to 70°C (-22°F to 158°F)	Shock	MIL-STD-810G Method 516.6 Procedure I
Vibration	MIL-STD-810G Method 514.6 Procedure I	IP rating	IP65
Drop	MIL-STD-810G Method 516.6, 5 ft		

Certification

Certification CE, FCC, E-Mark

Security Function

SOTI MobiControl SOTI MobiControl Compliance

Control

Button 1 x Power, 1 x menu, 3 x Programmable Function Keys

Power

Battery	7.6V, typ. 4200 mAh Li Polymer Battery (2S2P)	Battery Operating Time	8 Hours
Power Rating	19V DC	Adapter	100-240V, 50-60Hz / 19V DC

Accessory

Accessory	Adapter and Power Cord Standard Battery Pack	Optional Accessory	Desk Dock (Optional) Vehicle Dock (Optional) Vehicle Gateway (Optional) Vehicle Cradle (Optional) Battery Charger (Optional) Vehicle Charger (Optional) Hand Strap (Optional) Capacitive Stylus (Optional)
------------------	---	---------------------------	---

Barcode Scanner

Barcode Scanner 1D/2D barcode reader (Optional)

DIMENSIONS UNIT:MM

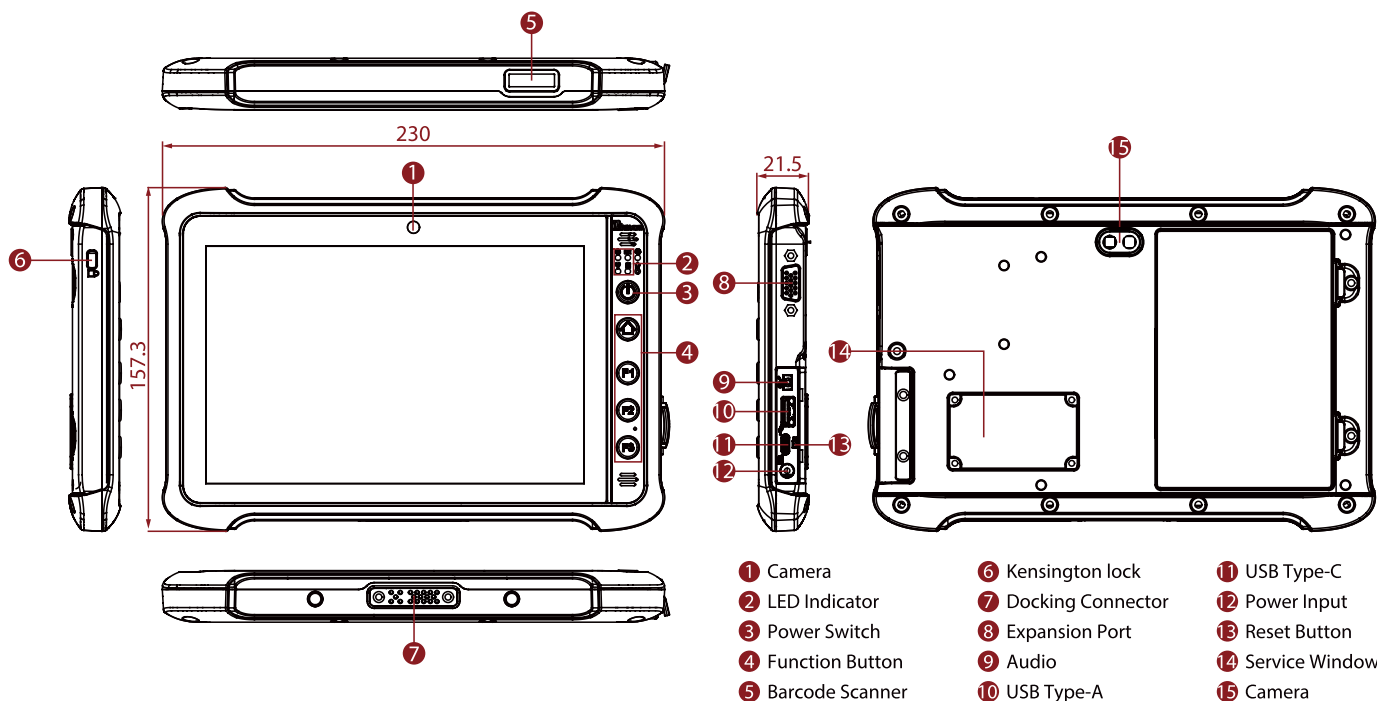

NOTE

1. Measured at dimming LCD brightness. Varies depending on the usage conditions, or when an external device is attached.
2. Total usable memory will be less dependent upon actual system configuration.
3. The USB Type-C connector follows USB 3.0 standard, which does not support Alternate Mode (ALT) or USB Power Delivery (USB-PD).
4. Barcode Reader and RFID Scanner are mutually exclusive options.
5. Length measurements do not include protrusions. Weight varies with options.
6. Measured at dimming LCD brightness. Varies depending on the usage conditions, or when an external device is attached.
7. Accessories and Integrated Options may vary depending on your configuration.
8. This is a simplified drawing and some components are not marked in detail.
9. The product shown in this datasheet is a standard model. For diagrams that contain customized or optional I/O, please contact the Winmate Sales Team for more information.