

SH960-HM170

HM170

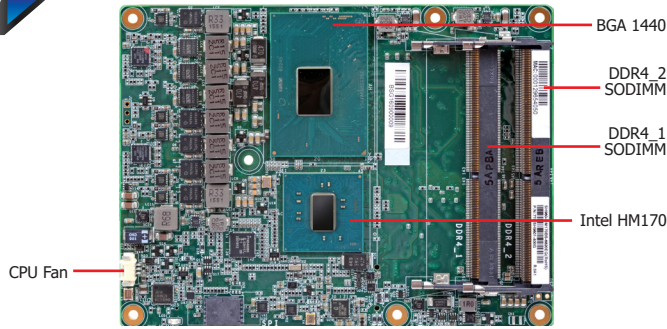

Features

- Dual channel DDR4 2133MHz SODIMM up to 32GB
- Four display ports: VGA*/DDI + LVDS*/eDP + 2 DDI Supports three independent displays
- eDP resolution supports up to 4096x2304 @ 60Hz
- Multiple expansion: 1 PCIe x16, 8 PCIe x1
- Rich I/O: 1 Intel GbE, 4 USB 3.0, 8 USB 2.0

* Populated by default



Mechanical Drawing

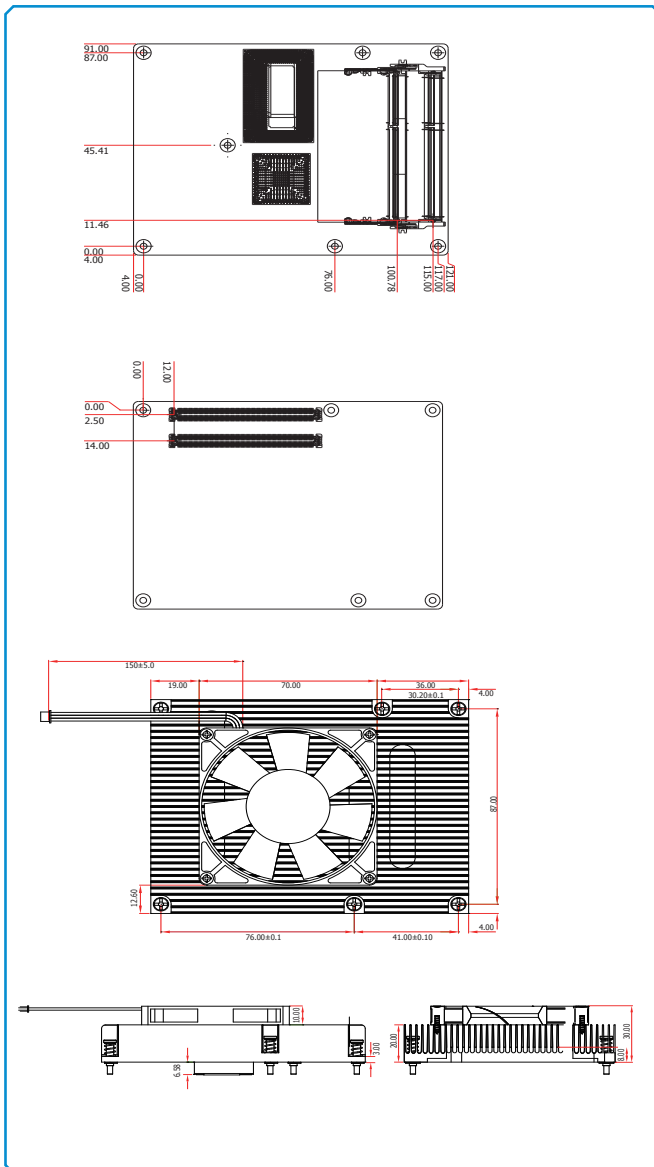

Block Diagram

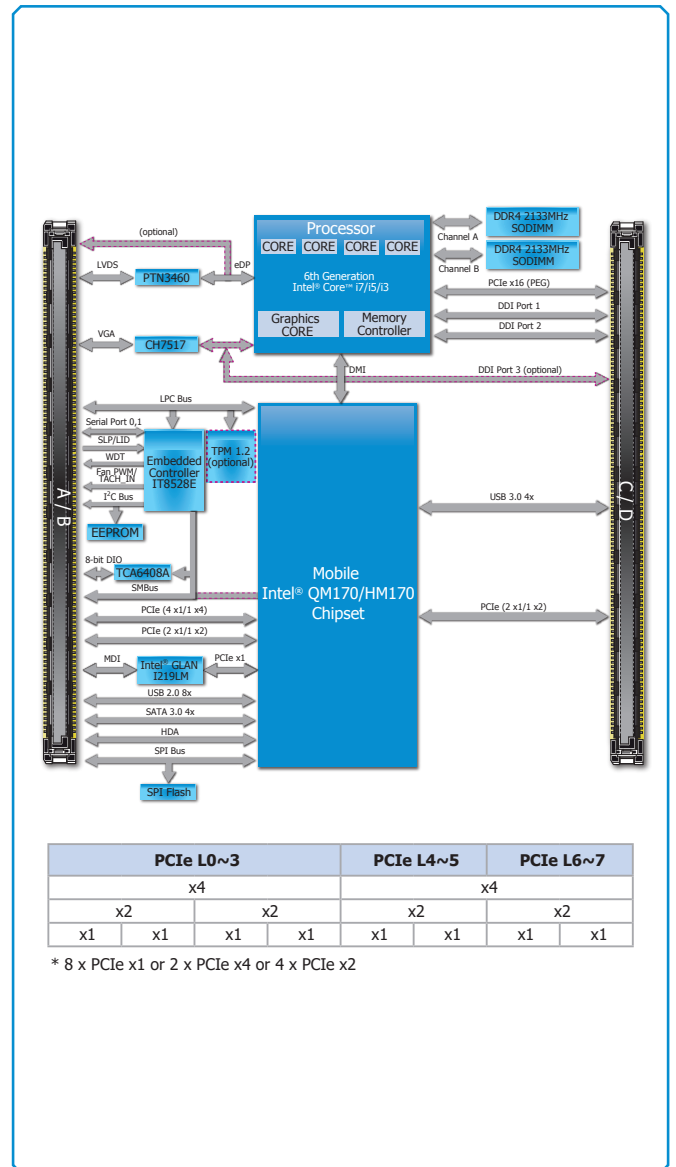

Specifications

SYSTEM	Processor	6th Generation Intel® Core™ Processors, BGA 1440 Intel® Core™ i7-6820EQ Processor, Quad Core, 8M Cache, 2.8GHz (3.5GHz), 45W Intel® Core™ i7-6822EQ Processor, Quad Core, 8M Cache, 2.0GHz (2.8GHz), 25W Intel® Core™ i5-6440EQ Processor, Quad Core, 6M Cache, 2.7GHz (3.4GHz), 45W Intel® Core™ i5-6442EQ Processor, Quad Core, 6M Cache, 1.9GHz (2.7GHz), 25W Intel® Core™ i3-6100E Processor, Dual Core, 3M Cache, 2.7GHz, 35W Intel® Core™ i3-6102E Processor, Dual Core, 3M Cache, 1.9GHz, 25W Intel® Celeron® Processor G3900E, Dual Core, 2M Cache, 2.4GHz, 35W Intel® Celeron® Processor G3902E, Dual Core, 2M Cache, 1.6GHz, 25W	
	Chipset	Intel® HM170 Chipset	
	Memory	Two 260-pin SODIMM up to 32GB	Dual Channel DDR4 2133MHz
	BIOS	Insyde SPI 128Mbit	
GRAPHICS	Controller	Intel® HD Graphics	
	Feature	OpenGL up to 4.4, DirectX 12, OpenCL 2.1 HW Decode: AVC/H.264, MPEG2, VC1/WMV9, JPEG/MJPEG, HEVC/H265, VP8, VP9 HW Encode: AVC/H.264, MPEG2, JPEG, HEVC/H265, VP8, VP9	
	Display	1 x VGA/DDI (DDI available upon request) 1 x LVDS/eDP (eDP available upon request) 2 x DDI (HDMI/DVI/DP++)	VGA: resolution up to 1920x1200 @ 60Hz LVDS: dual channel 24-bit, resolution up to 1920x1200 @ 60Hz HDMI: resolution up to 4096x2160 @ 24Hz or 2560x1600 @ 60Hz DVI: resolution up to 1920x1200 @ 60Hz DP++/eDP: resolution up to 4096x2304 @ 60Hz
	Triple Displays	VGA + LVDS + DDI or VGA + DDI1 + DDI2	eDP + 2 DDI (available upon request)
EXPANSION	Interface	1 x PCIe x16 or 2 x PCIe x8 (Gen 3) 8 x PCIe x1 or 2 x PCIe x4 or 4 x PCIe x2 (Gen 3) 1 x LPC 1 x I ² C 1 x SMBus 2 x UART (TX/RX)	
	Interface	HD Audio	
ETHERNET	Controller	1 x Intel® I219LM with iAMT11.0 PCIe (10/100/1000Mbps)	
I/O	USB	4 x USB 3.0 8 x USB 2.0	
	SATA	4 x SATA 3.0 (up to 6Gb/s)	RAID 0/1/5/10
	DIO	1 x 8-bit DIO	
	WATCHDOG TIMER	Output & Interval	System Reset, Programmable via Software from 1 to 255 Seconds
SECURITY	TPM	Available Upon Request	
POWER	Type	12V, 5VSB, VCC_RTC (ATX mode)	12V, VCC_RTC (AT mode)
	Consumption	TBD	
OS SUPPORT		Windows 8.1 64-bit Windows 7 (WES7) 32/64-bit Windows 10 IoT Enterprise 64-bit	Debian 8 (with VESA graphic driver) CentOS 7 (with VESA graphic driver) Linux
	ENVIRONMENT	Temperature	Operating: 0 to 60°C -40 to 85°C
	Humidity	Operating: 5 to 90% RH	Storage: 5 to 90% RH
	MTBF	663,394hrs @ 25°C; 334,612 hrs @ 45°C; 193,307 hrs @ 60°C excluding accessories Calculation Model: Telcordia Issue 2, Method Case 3 Environment: GB, GC – Ground Benign, Controlled	
MECHANICAL	Dimensions	COM Express® Basic	95mm (3.74") x 125mm (4.9")
	Compliance	PICMG COM Express® R2.1, Type 6	

Ordering Information

Model Name	P/N	Processor	Memory	VGA/DDI	LVDS/eDP	GbE	USB 3.0	USB 2.0	Power	Thermal	Temp.
SH960-HM170TS-6100E	770-SH9604-800G	i3-6100E	2 SODIMM	VGA	LVDS	1	4	8	ATX/AT	Cooler	-40 to 85°C

Note: Core i3 and Celeron are supported upon request with MOQ requirement.

Packing List

• 1 SH960-CM236/QM170 board	
• 1 Cooler (Height: 36.58mm)	A71-111026-000G

Optional Items

• COM332-B carrier board kit	770-CM3321-000G
• Heat spreader (Height: 11mm)	A71-011073-000G