

M101S

10.1" Rugged Tablet with Intel® Core™ i5-7200U



KEY FEATURES

- 7th Gen Intel® Core™ i5-7200U Kaby lake processor rugged tablet
- 10.1" 1920 x 1200 IPS LED Panel with direct optical bonding
- Sunlight readable with anti-glare solution, fully rugged tablet
- Hot-swappable battery design with optional High capacity battery pack
- IP65 waterproof and dustproof, MIL-STD-810G shock, vibration and drop resistance



SPECIFICATIONS

Display	
Resolution	1920x1200
Contrast Ratio	800:1
View Angles	85, 85, 85, 85
Viewability	Anti-Glare touch treatment
Size	10.1 inches
Panel Brightness	800 nits
Type	Projected Capacitive Multi Touch
Bonding	Optical Bonding for Sunlight Viewability
System Specification	
Processor	Intel Core i5-7200U 2.5GHz (up to 3.1GHz) Intel Core i5-7300U 2.6GHz (up to 3.5GHz) (Optional)
Memory	4GB DDR4 SDRAM 8GB DDR4 SDRAM (Optional) 16GB DDR4 SDRAM (Optional)
Storage	128GB SSD Additional storage available with micro SDXC card slot 256GB SSD (Optional) 512GB SSD (Optional)
Security	Trusted Platform Module (TPM) 2.0 Kensington Lock
Operating System	Windows 10 IoT Enterprise (64 bit)
WLAN	Support
BT	Support
WWAN	4G LTE (Optional)
GNSS	GPS, GLONASS
RFID	HF RFID reader 13.56 MHz (Optional)
Sensors	Light sensor/ G-sensor / Gyro
Camera	
Front Camera	2MP Front Camera
Rear Camera	8MP Rear Camera with auto-focus and LED light
Mechanical	
Dimension	271.8 x 197.2 x 21 mm (10.7 x 7.76 x 0.83 inches)
Weight	1.25 kg (2.75 lbs) with standard battery, 1.45 kg (3.2 lbs) with optional high capacity battery
Cooling System	Fan design
IO Ports	
USB Port	1 x USB 3.0 (Type A), 1 x USB 3.0 (Type C)
SD Card Slot	1 x Micro SDXC slot
SIM Card Slot	1 x Micro SIM card slot
Video	1 x Micro HDMI (Optional)
Audio	1 x Audio combo 3.5mm audio combo jack Dual Digital Mic With Noise Cancellation Dual Speaker
Indicator	4x LED Indicator for Power, Battery, HDD, RF status
Docking Connector	1 x 19-pin docking connector
Environment	

Operating Humidity	10% to 90% RH, non-condensing	Operating Temperature	-20°C to 60°C (AC mode), -10°C to 50°C (Battery mode)
Storage Temperature	-30°C to 70°C (-22°F to 158°F)	Shock	MIL-STD-810G Method 516.6 Procedure I
Vibration	MIL-STD-810G Method 514.6 Procedure I	IP rating	IP65
Drop	MIL-STD-810G Method 516.6, 4 ft		

Certification

Certification	CE, FCC
----------------------	---------

Security Function

SOTI MobiControl	SOTI MobiControl Compliance	Kensington Lock	Kensington Lock Support
-------------------------	-----------------------------	------------------------	-------------------------

Control

Button	1 x Power, 1 x Home 2 x volume key 2 x Programmable function Keys
---------------	---

Power

Battery	Hot-swappable 7.7V, typ. 5900 mAh Li-Polymer Battery (2S1P) 7.4V, typ. 10280 mAh Li-Polymer Battery (2S2P, optional)	Battery Operating Time	Standard. Battery: 8 hours High Capacity Battery: 16 hours
Power Rating	19V DC	Adapter	100-240V, 50-60Hz / 19V DC

Accessory

Accessory	Adapter and Power Cord Capacitive Stylus Standard Battery	Optional Accessory	Desk Dock (Optional) Vehicle Dock (without VGA output) (Optional) Vehicle Cradle (Optional) Vehicle Charger (Optional) High Capacity Battery (Optional) Battery Charger (Optional) Hand Strap (Optional) Shoulder Strap (Optional) Carry Bag (Optional) VESA Mount Kit (Optional)
------------------	---	---------------------------	--

Barcode Scanner

Barcode Scanner	1D/2D barcode reader (Optional)
------------------------	---------------------------------

DIMENSIONS UNIT:MM

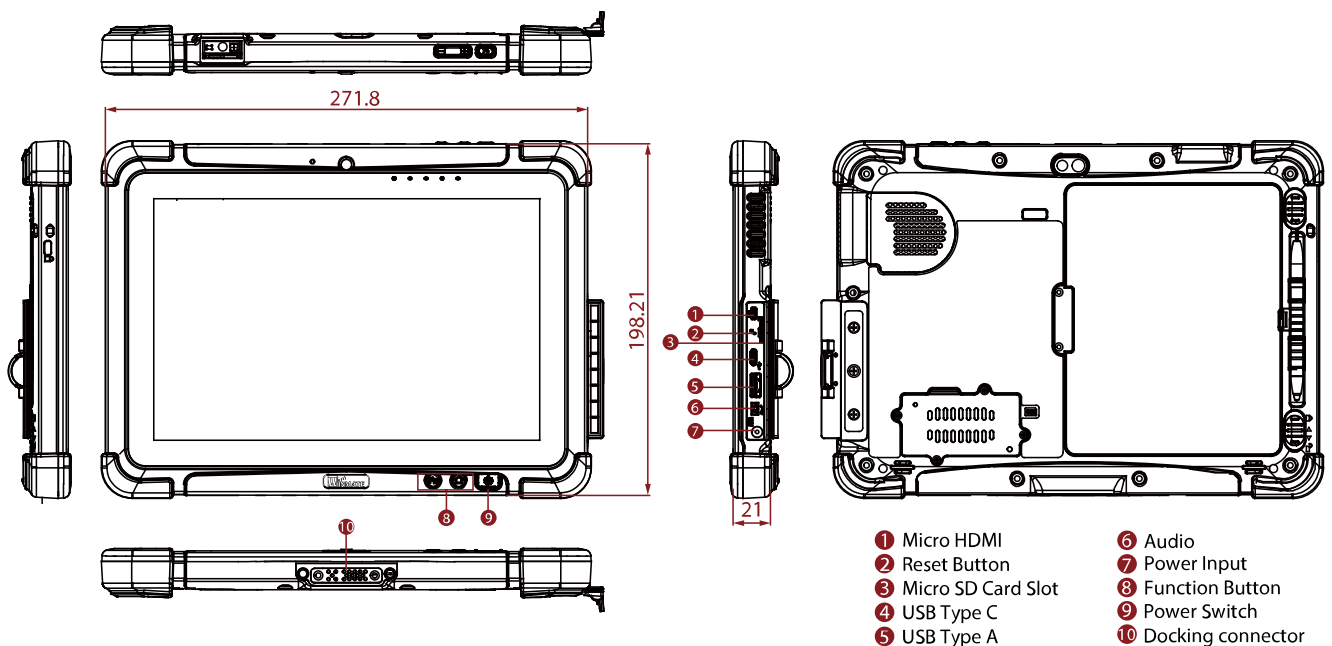

NOTE

1. Total usable memory will be less dependent upon actual system configuration.
2. The USB Type-C connector follows USB 3.0 standard, which does not support Alternate Mode (ALT) or USB Power Delivery (USB-PD).
3. TPM 2.0 available upon request.
4. SOTI is available upon request.
5. Measured at dimming LCD brightness. Varies depending on the usage conditions, or when an external device is attached.
6. Length measurements do not include protrusions. Weight varies with options and active pen.
7. The product shown in this datasheet is a standard model. For diagrams that contain customized or optional I/O, please contact the Winmate Sales Team for more information.
8. The drop test with a high-capacity battery must come with a hand strap.
9. Accessories and integrated options may vary depending on your configuration.
10. This is a simplified drawing and some components are not marked in detail.