

Datasheet

# mSATA

## 3IE4 series

- SATA 6.0 Gb/s interface
- Exclusive iSLC FW architecture
- Followed JEDEC MO-300/MO-300B standard
- LDPC technology secures SSD reliability
- DRAM-less, high-level data integrity
- L<sup>3</sup> architecture extends lifespan
- Excellent IOPS boosts system performance
- Built-in thermal sensor
- Support S.M.A.R.T, TRIM, and NCQ



## Introduction

Innodisk mSATA 3IE4 is SATA III 6.0 Gb/s flash based disk, which adopts latest Marvell NAND controller with Innodisk's exclusive L<sup>3</sup> FW architecture. The upgraded L<sup>3</sup> FW architecture, combining Innodisk signature 4K mapping algorithm L<sup>2</sup> FW architecture with powerful LDPC technology, makes 3IE4 series have outstanding high IOPS, better data integrity and extended lifespan through reducing the bad block number happening. Built-in thermal sensor, ensure data integrity and reliability of mSATA 3IE4 for industrial applications.

# mSATA

## 3IE4 series

Contact us for more information about the mSATA 3IE4.

Innodisk is a service-driven provider of industrial embedded flash and DRAM storage products and technologies, with a focus on the industrial/embedded, aerospace and defense, and cloud computing industries.

### Diagram

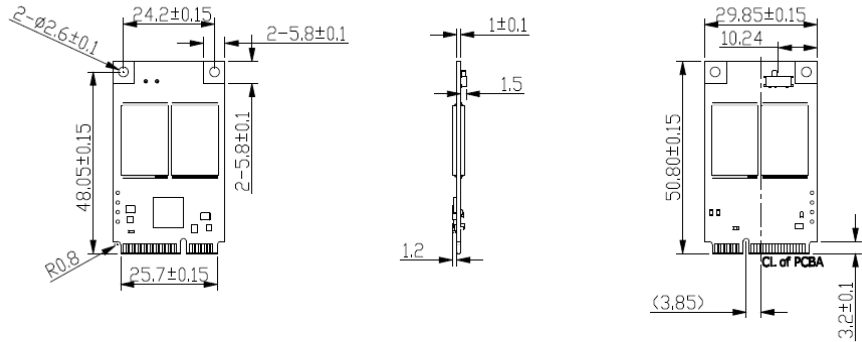

### Specifications

Interface	SATA III
Flash Type	iSLC
Capacity	8GB~128GB
Max. Channels	2
Sequential R/W (MB/sec, max.)*	530 / 365 MB/s
4KB Random (QD32) R/W (IOPS)**	31,000/31,000
Max. Power Consumption	0.6 W ( 3.3 V x 0.2 A )
Thermal Sensor	√
External DRAM Buffer	-
H/W Write Protect	Optional
ATA Security	√
S.M.A.R.T.	√
Dimension (WxLxH)	29.85 X 50.8 X 3.7 mm
Environment	Vibration: 20G @7~2000Hz Shock: 1500G @ 0.5ms Storage Temperature: -55°C ~ +95°C MTBF: 3 million hours
* Sequential performance based on CystalDiskMark 3.01 with file size 1000MB	
** Random performance based on Iometer with Queue Depth 32	

#### Headquarters (Taiwan)

5F., No.237, Sec. 1, Datong Rd., Xizhi Dist., New Taipei City, Taiwan (R.O.C.)  
Tel: +886-2-77033000  
Email: sales@innodisk.com

#### Branch Offices:

USA  
[usasales@innodisk.com](mailto:usasales@innodisk.com)  
+1-510-770-9421  
Europe  
[eusales@innodisk.com](mailto:eusales@innodisk.com)  
+31-40-3045-400  
Japan  
[jpsales@innodisk.com](mailto:jpsales@innodisk.com)  
+81-3-6667-0161  
China  
[sales\\_cn@innodisk.com](mailto:sales_cn@innodisk.com)  
+86-755-21673689  
[www.innodisk.com](http://www.innodisk.com)

© 2017 Innodisk Corporation.  
All right reserved. Specifications are subject to change without prior notice.

### Ordering Information (Please refer to TPS for detail)

Operation Temp.	8GB	16GB	32GB	64GB	128GB
Standard Grade (0°C ~ +70°C)	DHMSR-08GM41BC1DC DHMSR-08GM41BC1SC	DHMSR-16GM41BC1DC	DHMSR-32GM41BC1DC	DHMSR-64GM41BC1DC	DHMSR-A28M41BC1DC
Industrial Grade (-40°C ~ +85°C)	DHMSR-08GM41BC1DC DHMSR-08GM41BW1SC	DHMSR-16GM41BW1DC	DHMSR-32GM41BW1DC	DHMSR-64GM41BW1DC	DHMSR-A28M41BW1DC