

Datasheet

# SATADOM-ML

## 3SE series

- SATA 6Gb/s interface
- iSMART disk health monitoring
- Intelligent error recovery system
- Excellent data transfer speed
- Write protection security
- Zero mechanical interference
- Anti-vibration mechanical design



## Introduction

Innodisk SATADOM-ML 3SE is designed as the standard SATA 7 pin connector with SATA interface, and supports SATA III standard (6.0Gb/s) with excellent performance. Regarding of mechanical interference, Innodisk SATADOM-ML 3SE absolutely replaces the traditional hard disk and makes personal computer, in any field, smaller and easier.

Innodisk SATADOM-ML 3SE effectively reduces the booting time of operation system and the power consumption is less than hard disk drive (HDD), and complies with ATA protocol, no additional drives are required, and can be configured as a boot device or data storage device.

# SATADOM-ML

## 3SE series

Contact us for more information about the SATADOM-ML 3SE.

Innodisk is a service-driven provider of industrial embedded flash storage and Dram products and technologies, with a focus on the cloud computing, industrial/embedded, and aerospace and defense industries.

### Diagram

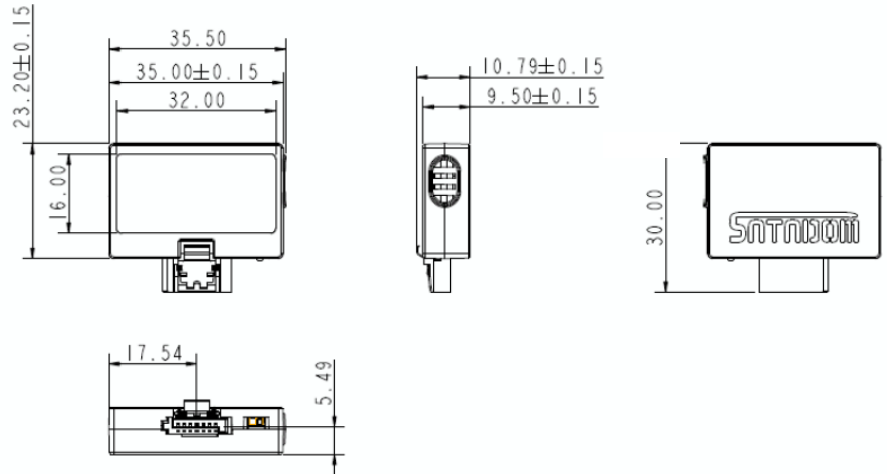

### Specifications

Interface	SATA III
Flash Type	SLC
Capacity	8GB~64GB
Max. Channels	4
Sequential R/W (MB/sec, max.)	490/250
Max. Power Consumption	2W (5V x 400mA )
Thermal Sensor	WT only
Extended DRAM buffer	-
H/W Write Protect	√
ATA Security	√
S.M.A.R.T.	√
Dimension (WxLxH)	35.5 X 30 X 9.5 mm
Environment	Vibration: 20G @7~2000Hz Shock: 1500G @ 0.5ms Storage Temperature: -55°C ~ +95°C MTBF: 3 million hours

#### Headquarters (Taiwan)

5F., No. 237, Sec. 1, Datong Rd.,  
Xizhi Dist., New Taipei City,  
Taiwan (R.O.C.)  
Tel: +886-2-7703-3000  
Email: sales@innodisk.com

#### Branch Offices:

USA  
[usasales@innodisk.com](mailto:usasales@innodisk.com)  
+1-510-770-9421  
Europe  
[eusales@innodisk.com](mailto:eusales@innodisk.com)  
+31-(0)40-282-1818  
Japan  
[jpsales@innodisk.com](mailto:jpsales@innodisk.com)  
+81-45-594-7581  
China  
[sales\\_cn@innodisk.com](mailto:sales_cn@innodisk.com)  
+86-755-21673689  
[www.innodisk.com](http://www.innodisk.com)

© 2014 Innodisk Corporation.  
All right reserved. Specifications  
are subject to change without  
prior notice.

### Ordering Information

Operation Temp.	8GB	16GB	32GB	64GB
Standard Grade (0°C ~ +70°C)	DESML-08GD06SCAQB(F)	DESML-16GD06SCAQB(F)	DESML-32GD06SCAQB(F)	DESML-64GD06SCAQB(F)
Industrial Grade (-40°C ~ +85°C)	DESML-08GD06SWAQB(F)	DESML-16GD06SWAQB (F)	DESML-32GD06SWAQB(F)	DESML-64GD06SWAQB(F)