

SATADOM-ML

3SE Series

Customer: _____
Customer
Part
Number: _____
Innodisk
Part
Number: _____
Innodisk
Model Name: _____
Date: _____

Innodisk Approver	Customer Approver

**Total Solution For
Industrial Flash Storage**

Table of contents

LIST OF FIGURES	6
1. PRODUCT OVERVIEW	7
1.1 INTRODUCTION OF INNODISK SATADOM-ML 3SE	7
1.2 PRODUCT VIEW AND MODELS	7
1.3 SATA INTERFACE	7
2. PRODUCT SPECIFICATIONS	8
2.1 CAPACITY AND DEVICE PARAMETERS	8
2.2 PERFORMANCE	8
2.3 ELECTRICAL SPECIFICATIONS	8
2.3.1 Power Requirement	8
2.3.2 Power Consumption	8
2.4 ENVIRONMENTAL SPECIFICATIONS	9
2.4.1 Temperature Ranges	9
2.4.2 Humidity	9
2.4.3 Shock and Vibration	9
2.4.4 Mean Time between Failures (MTBF)	9
2.5 CE AND FCC COMPATIBILITY	9
2.6 RoHS COMPLIANCE	9
2.7 RELIABILITY	10
2.8 TRANSFER MODE	10
2.9 PIN ASSIGNMENT	10
2.10 MECHANICAL DIMENSIONS	11
2.11 ASSEMBLY WEIGHT	11
2.12 SEEK TIME	11
2.13 HOT PLUG	11
2.14 NAND FLASH MEMORY	11
3. THEORY OF OPERATION	12
3.1 OVERVIEW	12
3.2 SATA III CONTROLLER	12
3.3 ERROR DETECTION AND CORRECTION	13
3.4 WEAR-LEVELING	13
3.5 BAD BLOCKS MANAGEMENT	13
3.6 POWER CYCLING	13
3.7 GARBAGE COLLECTION	13
4. INSTALLATION REQUIREMENTS	14
4.1 SATADOM-ML 3SE PIN DIRECTIONS	14

4.2 ELECTRICAL CONNECTIONS FOR SATADOM-ML 3SE	14
4.3 DEVICE DRIVE	14
4.4 PIN7 VCC	14
4.5 WRITE PROTECTION	15
5. PART NUMBER RULE	17

REVISION HISTORY

Revision	Description	Date
Rev. 1.0	First release	May, 2014
Rev. 1.1	Modify TBW based on NAND Flash specifications	Jan., 2015

List of Tables

TABLE 1: DEVICE PARAMETERS	8
TABLE 2: PERFORMANCE	8
TABLE 3: INNODISK SATADOM-ML 3SE POWER REQUIREMENT	8
TABLE 4: POWER CONSUMPTION	8
TABLE 5: TEMPERATURE RANGE FOR SATADOM-ML 3SE	9
TABLE 6: SHOCK/VIBRATION TESTING FOR SATADOM-ML 3SE	9
TABLE 7: SATADOM-ML 3SE MTBF	9
TABLE 8: INNODISK SATADOM-ML 3SE PIN ASSIGNMENT	10

List of Figures

FIGURE 1: INNODISK SATADOM-ML 3SE	7
FIGURE 2: INNODISK SATADOM-ML 3SE BLOCK DIAGRAM.....	12
FIGURE 3: SIGNAL SEGMENT AND POWER SEGMENT.....	14

1. Product Overview

1.1 Introduction of Innodisk SATADOM-ML 3SE

Innodisk Serial ATA Disk on Module (SATADOM) supports SATA III standard (6.0Gb/s) interface with excellent performance, and SATADOM-ML 3SE is designed as the smallest form factor size that could enhance compatibility with various design applications. Particularly the 7th pin of standard SATA 7pin connector can optionally be the built-in power VCC pin. In other words, it could be connected directly to the SATA on-board socket on customers' system without additional power cable. Besides, the booting time for operation and the power consumption is less than hard disk drive (HDD). SATADOM-ML 3SE can work under harsh environment compile with ATA protocol, no additional drives are required, and the SSD can be configured as a boot device or data storage device.

1.2 Product View and Models

Innodisk SATADOM-ML 3SE is available in follow capacities within MLC flash ICs.

[SATADOM-ML 3SE 8GB](#)

[SATADOM-ML 3SE 16GB](#)

[SATADOM-ML 3SE 32GB](#)

[SATADOM-ML 3SE 64GB](#)



Figure 1: Innodisk SATADOM-ML 3SE

1.3 SATA Interface

Innodisk SATADOM-ML 3SE supports SATA III interface, and compliant with SATA I and SATA II. SATA III interface can work with Serial Attached SCSI (SAS) host system, which is used in server computer. Innodisk SATADOM-ML 3SE is compliant with Serial ATA Gen 1, Gen 2 and Gen 3 specification (Gen 3 supports 1.5Gbps /3.0Gbps/6.0Gbps data rate). SATA connector uses a standard 7-pin signal segment.

2. Product Specifications

2.1 Capacity and Device Parameters

SATADOM-ML 3SE device parameters are shown in Table 1.

Table 1: Device parameters

Capacity	LBA	Cylinders	Heads	Sectors	User Capacity(MB)
8GB	15649200	15525	16	63	7,641
16GB	31277232	16383	16	63	15,272
32GB	62533296	16383	16	63	30,533
64GB	125045424	16383	16	63	61,057

2.2 Performance

Burst Transfer Rate: 6.0Gbps

Table 2: Performance

Capacity	8GB	16GB	32GB	64GB
Sequential Read (max.)	420 MB/sec	420 MB/sec	480 MB/sec	490 MB/sec
Sequential Write (max.)	110 MB/sec	125 MB/sec	260 MB/sec	250 MB/sec

Note: the information is based on CrystalDiskMark 3.01 with file size 1000MB test patent

2.3 Electrical Specifications

2.3.1 Power Requirement

Table 3: Innodisk SATADOM-ML 3SE Power Requirement

Item	Symbol	Rating	Unit
Input voltage	V _{IN}	+5 DC +- 5%	V

2.3.2 Power Consumption

Table 4: Power Consumption

Mode	Power Consumption (mA)
Read	360 (max.)
Write	400 (max.)
Idle	250 (max.)

* Target: 64GB SATADOM-ML 3SE

2.4 Environmental Specifications

2.4.1 Temperature Ranges

Table 5: Temperature range for SATADOM-ML 3SE

Temperature	Range
Operating	Standard Grade: 0°C to +70°C
	Industrial Grade: -40°C to +85°C
Storage	-55°C to +95°C

2.4.2 Humidity

Relative Humidity: 10-95%, non-condensing

2.4.3 Shock and Vibration

Table 6: Shock/Vibration Testing for SATADOM-ML 3SE

Reliability	Test Conditions	Reference Standards
Vibration	7 Hz to 2K Hz, 20G, 3 axes	IEC 68-2-6
Mechanical Shock	Duration: 0.5ms, 1500 G, 3 axes	IEC 68-2-27

2.4.4 Mean Time between Failures (MTBF)

Table 7 summarizes the MTBF prediction results for various SATADOM-ML 3SE configurations. The analysis was performed using a RAM Commander™ failure rate prediction.

- **Failure Rate:** The total number of failures within an item population, divided by the total number of life units expended by that population, during a particular measurement interval under stated condition.
- **Mean Time between Failures (MTBF):** A basic measure of reliability for repairable items: The mean number of life units during which all parts of the item perform within their specified limits, during a particular measurement interval under stated conditions.

Table 7: SATADOM-ML 3SE MTBF

Product	Condition	MTBF (Hours)
Innodisk SATADOM-ML 3SE	Telcordia SR-332 GB, 25°C	>3,000,000

2.5 CE and FCC Compatibility

SATADOM-ML 3SE conforms to CE and FCC requirements.

2.6 RoHS Compliance

SATADOM-ML 3SE is fully compliant with RoHS directive.

2.7 Reliability

Parameter	Value
Read Cycles	Unlimited Read Cycles
Wear-Leveling Algorithm	Support
Bad Blocks Management	Support
Error Correct Code	Support
TBW(Sequential Write)	
8GB	432 (Sequential write)
16GB	864 (Sequential write)
32GB	1728 (Sequential write)
64GB	3456 (Sequential write)

2.8 Transfer Mode

SATADOM-ML 3SE support following transfer mode:

Serial ATA I 1.5Gbps

Serial ATA II 3.0Gbps

Serial ATA III 6.0Gbps

2.9 Pin Assignment

Innodisk SATADOM-ML 3SE uses a standard SATA pin-out. See Table 8 for SATADOM-ML 3SE pin assignment.

Table 8: Innodisk SATADOM-ML 3SE Pin Assignment

Name	Type	Description
Pin 1	GND	Shielding
Pin 2	A+	Differential signal to A
Pin 3	A-	Differential signal to A-
Pin 4	GND	Shielding
Pin 5	B-	Differential signal to B-
Pin 6	B+	Differential signal to B
Pin 7	GND/VCC	Shielding/Power*

CAUTION

SATADOM Pin 7 with power supply version (PN end with F) is provided with different model and PN, which request specific M/B designed with 5V power supply through SATA port(7th Pin), and cannot use external cable for power supply!

2.10 Mechanical Dimensions

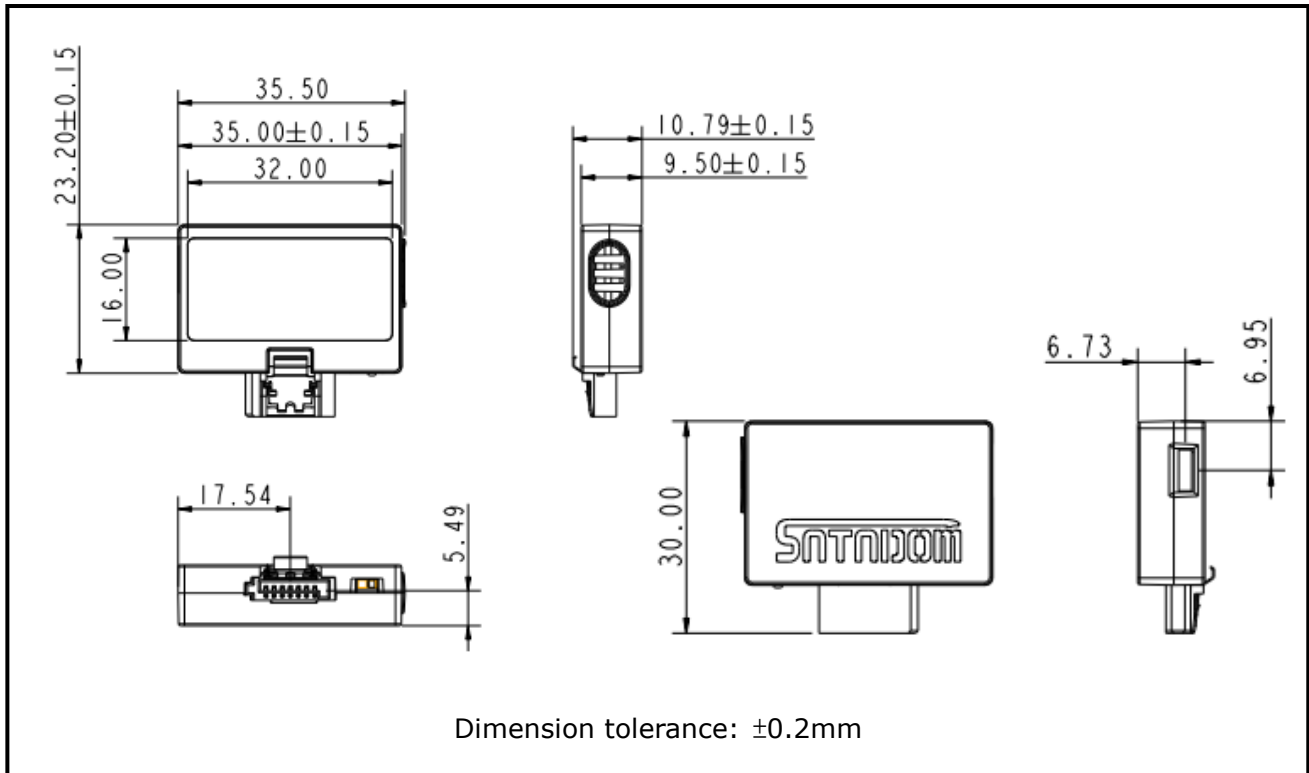

2.11 Assembly Weight

An Innodisk SATADOM-ML 3SE within flash ICs, 32GB's weight is 9 grams approximately.

2.12 Seek Time

Innodisk SATADOM-ML 3SE is not a magnetic rotating design. There is no seek or rotational latency required.

2.13 Hot Plug

The SSD support hot plug function and can be removed or plugged-in during operation. User has to avoid hot plugging the SSD which is configured as boot device and installed operation system.

Surprise hot plug : The insertion of a SATA device into a backplane (combine signal and power) that has power present. The device powers up and initiates an OOB sequence.

Surprise hot removal: The removal of a SATA device from a powered backplane, without first being placed in a quiescent state.

2.14 NAND Flash Memory

Innodisk SATADOM-ML 3SE uses Multi Level Cell (MLC) NAND flash memory, which is non-volatility, high reliability and high speed memory storage. Each cell stores 2 bits or holds four states per cell. Read or Write data to flash memory for SSD is control by microprocessor.

3. Theory of Operation

3.1 Overview

Figure 2 shows the operation of Innodisk SATADOM-ML 3SE from the system level, including the major hardware blocks.

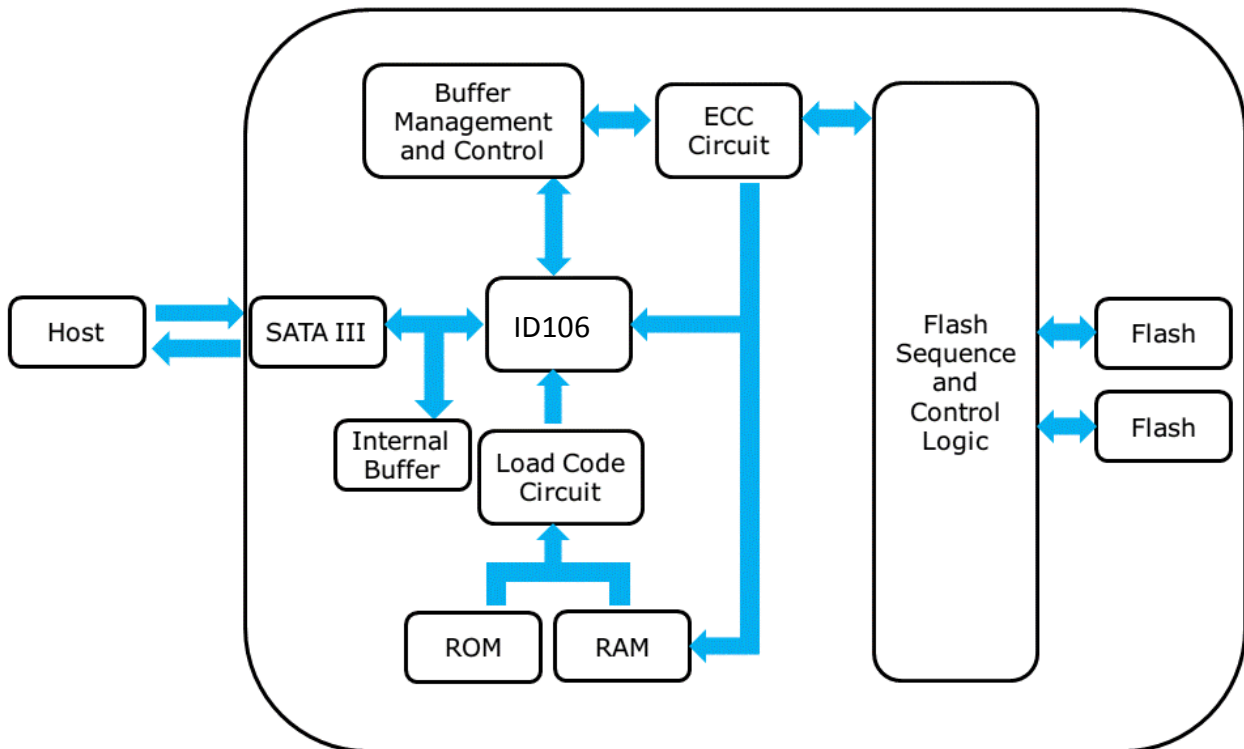

Figure 2: Innodisk SATADOM-ML 3SE Block Diagram

Innodisk SATADOM-ML 3SE integrates a SATA III controller and NAND flash memories. Communication with the host occurs through the host interface, using the standard ATA protocol. Communication with the flash device(s) occurs through the flash interface.

3.2 SATA III Controller

Innodisk SATADOM-ML 3SE is designed with ID 167, a SATA III 6.0Gbps (Gen. 3) controller. The Serial ATA physical, link and transport layers are compliant with Serial ATA Gen 1, Gen 2 and Gen 3 specification (Gen 3 supports 1.5Gbps/3.0Gbps/6.0Gbps data rate). The controller has 2 channels for flash interface.

3.3 Error Detection and Correction

Highly sophisticated Error Correction Code algorithms are implemented. The ECC unit consists of the Parity Unit (parity-byte generation) and the Syndrome Unit (syndrome-byte computation). This unit implements an algorithm that can correct 40 bits per 1024 bytes in an ECC block. Code-byte generation during write operations, as well as error detection during read operation, is implemented on the fly without any speed penalties.

3.4 Wear-Leveling

Flash memory can be erased within a limited number of times. This number is called the **erase cycle limit** or **write endurance limit** and is defined by the flash array vendor. The erase cycle limit applies to each individual erase block in the flash device.

Innodisk SATADOM-ML 3SE uses a static wear-leveling algorithm to ensure that consecutive writes of a specific sector are not written physically to the same page/block in the flash. This spreads flash media usage evenly across all pages, thereby extending flash lifetime.

3.5 Bad Blocks Management

Bad Blocks are blocks that contain one or more invalid bits whose reliability are not guaranteed. The Bad Blocks may be presented while the SSD is shipped, or may develop during the life time of the SSD. When the Bad Blocks is detected, it will be flagged, and not be used anymore. The SSD implement Bad Blocks management, Bad Blocks replacement, Error Correct Code to avoid data error occurred. The functions will be enabled automatically to transfer data from Bad Blocks to spare blocks, and correct error bit.

3.6 Power Cycling

Innodisk's power cycling management is a comprehensive data protection mechanism that functions before and after a sudden power outage to SSD. Low-power detection terminates data writing before an abnormal power-off, while table-remapping after power-on deletes corrupt data and maintains data integrity. Innodisk's power cycling provides effective power cycling management, preventing data stored in flash from degrading with use.

3.7 Garbage Collection

Garbage collection is used to maintain data consistency and perform continual data cleansing on SSDs. It runs as a background process, freeing up valuable controller resources while sorting good data into available blocks, and deleting bad blocks. It also significantly reduces write operations to the drive, thereby increasing the SSD's speed and lifespan.

4. Installation Requirements

4.1 SATADOM-ML 3SE Pin Directions

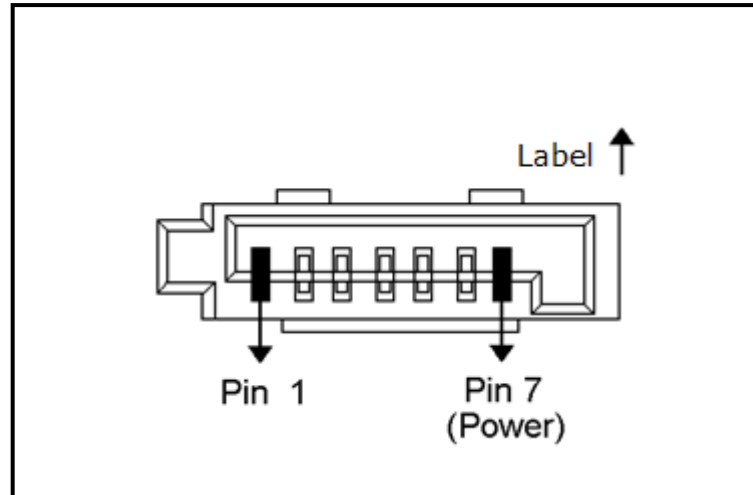

Figure 3: Signal Segment and Power Segment

4.2 Electrical Connections for SATADOM-ML 3SE

A Serial ATA device may be either directly connected to a host or connected to a host through a cable. For connection via cable, the cable should be no longer than 1meter. The SATA interface has a separate connector for the power supply. Please refer to the pin description for further details.

4.3 Device Drive

No additional device drives are required. The Innodisk SATADOM-ML 3SE can be configured as a boot device.

4.4 Pin7 VCC

SATADOM-ML 3SE series with Pin7 VCC, it is defined Pin7 as VCC on the SATA connector. Thus the power would come from SATA connector Pin7 VCC. Customers DO NOT have to use the power cable for power supply. Such a wireless design of SATADOM-ML 3SE series with Pin7 VCC brings more convenience to customers' system. The followings are the points customers have to be careful of while designing in SATADOM-ML 3SE series with Pin7 VCC.

SATADOM-ML 3SE series with Pin7 VCC is designed with a fuse (poly switch 500mA, 6V) on Pin7's circuit. Such a design could avoid any potential damage to customers' system.

When customers use SATADOM-ML 3SE with Pin7 VCC and the host SATA socket does not have

power on pin 7, external power must be provided to the SATADOM from the 2pin connector on the side.

To have the advantages of SATADOM-ML 3SE series with Pin7 VCC, and to avoid any potential damage to customers' board designed with VCC power supply, Innodisk suggests that customers MUST design their board with a fuse which should be designed before the SATA socket Pin7 VCC. In other words, customers are suggested NOT TO layout 5V VCC to SATA socket on board directly. A circuit diagram example to explain this is shown as below.

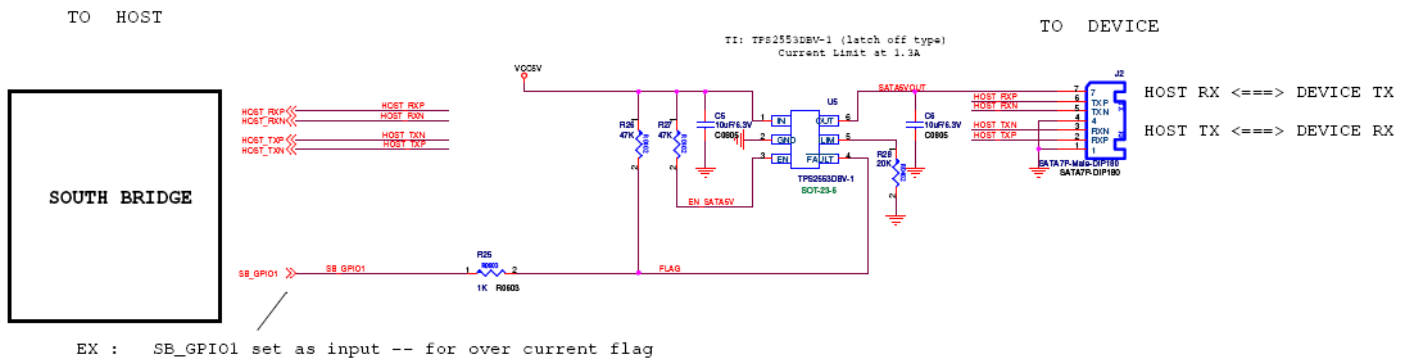

4.5 Write Protection



SATADOM-ML 3SE within the write-protect function could prevent the device from modification and deletion. Write-protected data could only be read, that is, users could not write to it, edit it, append data to it, or delete it. When users would like to make sure that neither themselves nor others could modify or destroy the file, users could switch on write-protection. Thus, SATADOM-ML 3SE could process write-protect mechanism and disable flash memory to be written-in any data. Only while the system power-off, users could switch on write-protection. Write-protection could not be switched-on, after OS booting.

4.6 Power cable

A power cable is shipped with each SATADOM product, which has standard 4pins power connector and special 3 pins power connector for SATADOM. The male and female power connector of SATADOM have foolproof design to avoid misconnection, please check the connector and power polarity before power on.

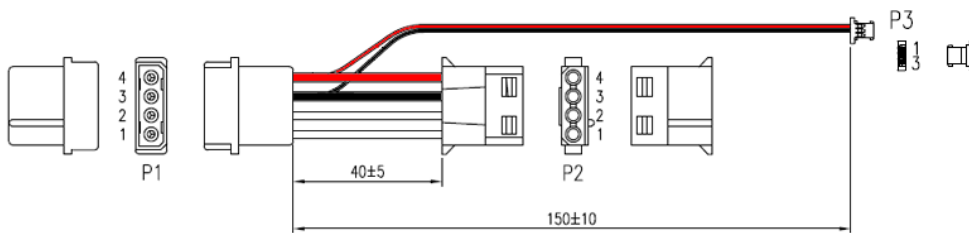
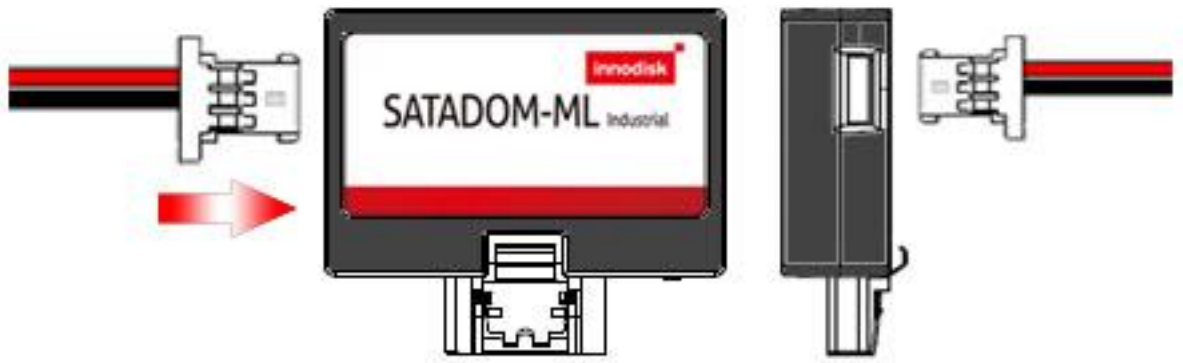

* PN end with F is SATADOM Pin 7 with power supply version, which doesn't provide power cable.

5. Part Number Rule

CODE	1	2	3	4	5	6	7	8	9	10	11	12	13	14	15	16	17	18	19	20	21
	D	E	S	M	L	-	3	2	G	D	0	6	S	C	A	Q	C	-	X	X	X
Definition																					
Code 1st (Disk)											Code 14th (Operation Temperature)										
D : Disk											C: Standard Grade (0°C ~ +70°C)										
Code 2nd (Feature set)											Code 15th (Internal control)										
E : Embedded series											W: Industrial Grade (-40°C ~ +85°C)										
Code 3rd ~5th (Form factor)											A: BGA PCB version.										
SML: SATADOM-ML series											Code 16th (Channel of data transfer)										
Code 7th ~9th (Capacity)											D: Dual Channels										
08G:8GB	16G:16GB	32G:32GB	64G:64GB																		
											Q: Four Channels										
Code 10th ~12th (Controller)																					
D06: ID106											Code 17th (Flash Type)										
											B: Toshiba SLC										
Code 13th (Flash mode)											Code 18th (pin7 type)										
S: Synchronous NAND.											F: Pin7 version (Optional)										
											Code 19th~21st (Customize code)										

Certificate

Issue Date: May 7, 2014
Ref. Report No. ISL-14LE178CE

Product Name : SATADOM-ML 3MG-P/3SE-P/3IE-P; SATADOM-ML 3ME/3SE/3IE
Model(s) : D@SML-XXXD67*#%※&; D@SML-XXXD06*#%※&
Responsible Party : Innodisk Corporation
Address : 5F.No.237, Sec. 1, Datong Rd., Xizhi Dist.,
New Taipei City 221, Taiwan (R.O.C.)

We, International Standards Laboratory, hereby certify that:

The device bearing the trade name and model specified above has been shown to comply with the applicable technical standards as indicated in the measurement report and was tested in accordance with the measurement procedures specified in European Council Directive- EMC Directive 2004/108/EC. The device was passed the test performed according to :



Standards:

EN 55022: 2010 and CISPR 22: 2008 (modified)
EN 61000-3-2: 2006+A1:2009 +A2:2009 and IEC 61000-3-2: 2005+A1:2008 +A2:2009
EN 61000-3-3: 2008 and IEC 61000-3-3: 2008
EN 55024: 2010 and CISPR 24: 2010
EN 61000-4-2: 2009 and IEC 61000-4-2: 2008
EN 61000-4-3: 2006+A1: 2008 +A2: 2010 and
IEC 61000-4-3:2006+A1: 2007+A2: 2010
EN 61000-4-4: 2004 +A1:2010 and IEC 61000-4-4: 2004 +A1:2010

I attest to the accuracy of data and all measurements reported herein were performed by me or were made under my supervision and are correct to the best of my knowledge and belief. I assume full responsibility for the completeness of these measurements and vouch for the qualifications of all persons taking them.

International Standards Laboratory

Jim Chu
Jim Chu / Director

Hsi-Chih LAB:

No. 65, Gu Dai Keng Street, Hsi-Chih Dist.,
New Taipei City 221, Taiwan
Tel: 886-2-2646-2550; Fax: 886-2-2646-4641



Lung-Tan LAB:

No. 120, Lane 180, San Ho Tsuen, Hsin Ho Rd.,
Lung-Tan Hsiang, Tao Yuan County 325, Taiwan
Tel: 886-3-407-1718; Fax: 886-3407-1738



Certificate

Issue Date: May 7, 2014
Ref. Report No. ISL-14LE178FB

Product Name : SATADOM-ML 3MG-P/3SE-P/3IE-P; SATADOM-ML 3ME/3SE/3IE
Model(s) : D@SML-XXXD67*#%#&; D@SML-XXXD06*#%#&
Applicant : Innodisk Corporation
Address : 5F.No.237, Sec. 1, Datong Rd., Xizhi Dist.,
New Taipei City 221, Taiwan (R.O.C.)

We, **International Standards Laboratory**, hereby certify that:

The device bearing the trade name and model specified above has been shown to comply with the applicable technical standards as indicated in the measurement report and was tested in accordance with the measurement procedures specified. (refer to Test Report if any modifications were made for compliance).



Standards:

FCC CFR Title 47 Part 15 Subpart B: 2012- Section 15.107 and 15.109
ANSI C63.4-2009

Class B

I attest to the accuracy of data and all measurements reported herein were performed by me or were made under my supervision and are correct to the best of my knowledge and belief. I assume full responsibility for the completeness of these measurements and vouch for the qualifications of all persons taking them.

International Standards Laboratory

Jim Chu
Jim Chu / Director

Hsi-Chih LAB:
No. 65, Gu Dai Keng Street, Hsi-Chih Dist.,
New Taipei City 221, Taiwan
Tel: 886-2-2646-2550; Fax: 886-2-2646-4641

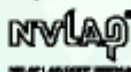

Lung-Tan LAB:
No. 120, Lane 180, San Ho Tsuen, Hsin Ho Rd.,
Lung-Tan Hsiang, Tao Yuan County 325, Taiwan
Tel: 886-3-407-1718; Fax: 886-3407-1738



innodisk

宜鼎國際股份有限公司 Innodisk Corporation

Tel:(02)2696-3000 Fax:(02)2696-2000 Internet: <http://www.innodisk.com/>

REACH Declaration of Conformity

Manufacturer Products: All Innodisk EM Flash and Dram products

1.宜鼎國際股份有限公司（以下稱本公司）特此保證此售予貴公司之產品，皆符合歐盟化學品法案(Registration, Evaluation and Authorization of Chemicals; REACH)之規定 (<http://www.echa.europa.eu/de/candidate-list-table> **last updated: 16/12/2013**)。所提供之產品包含：(1) 產品或產品所使用到的所有原物料；(2)包裝材料；(3)設計、生產及重工過程中所使用到的所有原物料。

We Innodisk Corporation hereby declare that our products are in compliance with the requirements according to the REACH Regulation

(<http://www.echa.europa.eu/de/candidate-list-table> **last updated: 16/12/2013**).

Products include : 1) Product and raw material used by the product : 2) Packaging material ; 3) Raw material used in the process of design, production and rework

2.本公司同意因本保證書或與本保證書相關事宜有所爭議時，雙方宜友好協商，達成協議。

InnoDisk Corporation agrees that both parties shall settle any dispute arising from or in connection with this Declaration of Conformity by friendly negotiations.

立 保 證 書 人 (Guarantor)

Company name 公司名稱：InnoDisk Corporation 宜鼎國際股份有限公司

Address：9F, No. 100, Sec.1 Xintai 5th Rd., Xizhi Dist., New Taipei City 221, Taiwan

Company Representative 公司代表人：Richard Lee 李鐘亮

Company Representative Title 公司代表人職稱：CEO 執行長

Date 日期：2014 / 03 / 18



RoHS 自我宣告書 (RoHS Declaration of Conformity)

Manufacturer Product: All Innodisk EM Flash and Dram products

宜鼎國際股份有限公司 (以下稱本公司) 特此保證售予貴公司之所有產品, 皆符合歐盟 2011/65/EU 關於 RoHS 之規範要求。

InnoDisk Corporation declares that all products sold to the company, are complied with European Union RoHS Directive (2011/65/EU) requirement

一、本公司同意因本保證書或與本保證書相關事宜有所爭議時, 雙方宜友好協商, 達成協議。

InnoDisk Corporation agrees that both parties shall settle any dispute arising from or in connection with this Declaration of Conformity by friendly negotiations.

Name of hazardous substance	Limited of RoHS ppm (mg/kg)
Cd	< 100 ppm
Pb	< 1000 ppm
Hg	< 1000 ppm
Chromium VI (Cr+6)	< 1000 ppm
Polybromodiphenyl ether (PBDE)	< 1000 ppm
Polybrominated Biphenyls (PBB)	< 1000 ppm

立保證書人

Company name 公司名稱: InnoDisk Corporation 宜鼎國際股份有限公司

Company Representative 公司代表人: Richard Lee 李鐘亮

Company Representative Title 公司代表人職稱: CEO 執行長

Date 日期: 2013 / 09 / 25

