

ARC-1209/1509

12.1"/15" Intel® Atom™ SoC Processor E3845 /Intel® Celeron® J1900 Fanless Rugged Touch Panel PC with IET Expansion

Quick Reference Guide

4th Ed – 22 June 2018

Copyright Notice

Copyright © 2018 ALL RIGHTS RESERVED.

Part No. E2017A290A5R

FCC Statement



THIS DEVICE COMPLIES WITH PART 15 FCC RULES. OPERATION IS SUBJECT TO THE FOLLOWING TWO CONDITIONS:

(1) THIS DEVICE MAY NOT CAUSE HARMFUL INTERFERENCE.

(2) THIS DEVICE MUST ACCEPT ANY INTERFERENCE RECEIVED INCLUDING INTERFERENCE THAT MAY CAUSE UNDESIRE OPERATION.

THIS EQUIPMENT HAS BEEN TESTED AND FOUND TO COMPLY WITH THE LIMITS FOR A CLASS "A" DIGITAL DEVICE, PURSUANT TO PART 15 OF THE FCC RULES.

THESE LIMITS ARE DESIGNED TO PROVIDE REASONABLE PROTECTION AGAINST HARMFUL INTERFERENCE WHEN THE EQUIPMENT IS OPERATED IN A COMMERCIAL ENVIRONMENT. THIS EQUIPMENT GENERATES, USES, AND CAN RADIATE RADIO FREQUENCY ENERGY AND, IF NOT INSTALLED AND USED IN ACCORDANCE WITH THE INSTRUCTION MANUAL, MAY CAUSE HARMFUL INTERFERENCE TO RADIO COMMUNICATIONS.

OPERATION OF THIS EQUIPMENT IN A RESIDENTIAL AREA IS LIKELY TO CAUSE HARMFUL INTERFERENCE IN WHICH CASE THE USER WILL BE REQUIRED TO CORRECT THE INTERFERENCE AT HIS OWN EXPENSE.

A Message to the Customer

Customer Services

Each product is built to the most exacting specifications to ensure reliable performance in the harsh and demanding conditions typical of industrial environments. Whether your new device is destined for the laboratory or the factory floor, you can be assured that your product will provide the reliability and ease of operation.

Your satisfaction is our primary concern. Here is a guide to our customer services. To ensure you get the full benefit of our services, please follow the instructions below carefully.

Technical Support

We want you to get the maximum performance from your products. So if you run into technical difficulties, we are here to help. For the most frequently asked questions, you can easily find answers in your product documentation. These answers are normally a lot more detailed than the ones we can give over the phone. So please consult the user's manual first.

Content

1.	Getting Started	6
1.1	Safety Precautions	6
1.2	Packing List.....	6
1.3	System Specifications	7
1.4	System Overview	10
1.4.1	I/O View	10
1.5	System Dimensions	11
1.5.1	ARC-1209 (A Model)	11
1.5.2	ARC-1209 (B Model)	12
1.5.3	ARC-1509 (A Model)	13
1.5.4	ARC-1509 (B Model)	14
2.	Hardware Configuration	15
2.1	ARC-1209/1509 connector mapping.....	16
2.1.1	Serial port 1 connector (COM1).....	16
2.1.2	Serial port 2 connector (COM2).....	16
2.2	Installing Hard Disk & Memory	17
2.3	Installing ARC-BYT DB	19
2.4	ARC-BYT Overviews.....	21
2.5	ARC-BYT Jumper and Connector list.....	22
2.6	ARC-BYT Jumpers & Connectors settings.....	23
2.6.1	Clear CMOS (JCMOS1)	23
2.6.2	Serial port 1/2 pin9 signal select (JRI1/JRI2)	23
2.6.3	LCD backlight brightness adjustment (JVR1).....	24
2.6.4	AT/ATX Input power select (JAT1)	24
2.6.5	Serial port 1 in RS-422/485 mode (JP1)	25
2.6.6	LCD Inverter connector (JBKL1)	25
2.6.7	On-board header for USB2.0 (H_JUSB3)	26
2.6.8	SATA Power connector (JSATA2P1)	26
2.6.9	LVDS connector (JLVDS1)	27
2.6.10	Battery connector (BT1)	28
2.6.20	Power connector (PWR1).....	33
2.7	ARC-BYT DB-A/B/C/D/E/F/G/H/K Overviews	34
2.7.1	ARC-BYT DB-A	34
2.7.2	ARC-BYT DB-B	34

ARC-1209/1509

2.7.3	ARC-BYT DB-C	34
2.7.4	ARC-BYT DB-D	35
2.7.5	ARC-BYT DB-E	35
2.7.6	ARC-BYT DB-F.....	35
2.7.7	ARC-BYT DB-G	36
2.7.8	ARC-BYT DB-H	36
2.7.9	ARC-BYT DB-K	36
2.8	ARC-BYT DB-A/B/C/D/E/F/G/H/K Connector list	37
2.8.1	ARC-BYT DB-A	37
2.8.2	ARC-BYT DB-B	37
2.8.3	ARC-BYT DB-C	37
2.8.4	ARC-BYT DB-D	37
2.8.5	ARC-BYT DB-E	37
2.8.6	ARC-BYT DB-F.....	38
2.8.7	ARC-BYT DB-G	38
2.8.8	ARC-BYT DB-H	38
2.8.9	ARC-BYT DB-K	38
2.9	ARC-BYT DB-D Connectors settings	40
2.9.1	Serial Port 1 connector (D_COM1).....	40
2.9.2	Serial Port 2 connector (D_COM2).....	40
2.10	ARC-BYT DB-E Jumpers & Connectors settings	41
2.10.1	CAN2.0 Switch (E_JCAN20)	41
2.10.2	For user update FW (E_JBOOT0).....	41
2.10.3	For user update FW (E_JIAP1)	42
2.11	ARC-BYT DB-F Connectors settings	44
2.12	ARC-BYT DB-H Jumpers settings.....	45
2.12.1	USB Power selector (H_USB_PWR_SEL1).....	45
2.13	ARC-BYT DB-G Connectors settings.....	45
2.13.1	Serial Port 1 connector (G_COM1)	45
2.13.2	Serial Port 2 connector (G_COM2)	46
2.13.3	Serial Port 3 connector (G_COM3)	46
2.14	ARC-BYT DB-H Connectors settings	47
2.14.1	Serial Port 1 connector (H_COM1).....	47
2.14.2	Serial Port 2 connector (H_COM2).....	47
2.15	ARC-BYT DB-K Connectors settings	48
2.15.1	Serial Port 1 connector (I_COM1)	48
2.15.2	Serial Port 2 connector (I_COM2)	48
3	BIOS Setup	49
3.1	Introduction	50
3.2	Starting Setup	50

3.3 Using Setup51

3.4 Getting Help52

3.5 In Case of Problems.....52

3.6 BIOS setup.....53

 3.6.1 Advanced Menu..... 53

 3.6.1.1 IT8528 Super IO Configuration 53

1. Getting Started

1.1 Safety Precautions

Warning!



Always completely disconnect the power cord from your chassis whenever you work with the hardware. Do not make connections while the power is on. Sensitive electronic components can be damaged by sudden power surges. Only experienced electronics personnel should open the PC chassis.

Caution!



Always ground yourself to remove any static charge before touching the CPU card. Modern electronic devices are very sensitive to static electric charges. As a safety precaution, use a grounding wrist strap at all times. Place all electronic components in a static-dissipative surface or static-shielded bag when they are not in the chassis.

1.2 Packing List

- 1 x ARC-1209/1509 Panel PC
- 1 x Power Adapter
- 1 x Power cord
- 4 x screws for VESA



If any of the above items is damaged or missing, contact your retailer.

1.3 System Specifications

Panel	ARC-1209	ARC-1509
LCD Size	12.1", 4:3	15", 4:3
Display Type	XGA	
Resolution	1024 x 768	
Pixel pitch	0.1905 mm (H) x 0.1905 mm (V)	0.297mm(H) x 0.297mm(V)
Luminance	600 cd/m ²	400 cd/m ²
Contrast ratio	700	
Viewing angle	80 (U), 80 (D), 80 (L), 80 (R)	70 (U), 70 (D), 80 (L), 80 (R)
Response time	16ms	
Backlight	LED	
Touch Type	5 Wires resistive (A Model) Projected Capacitive (B Model)	
Touch Light Transmission	80% (A Model) 89% (B Model)	
Touch Controller	Onboard USB touch (PenMount) (A Model) EETI (B Model)	
System		
SBC	ARC-BYT	
Processor	Intel® Atom™ E3845 4-Core 1.91GHz (A Model) Intel® Celeron® J1900 4-Core 2.0Ghz (B Model)	
I/O Chipset	EC ITE IT8528E	
System Memory	1 x 204-Pin DDR3L 1333MHz SO-DIMM up to 8 GB	
Watchdog Timer	H/W Reset, 1sec. ~ 65535sec./1sec.step	
H/W Status Monitor	Monitoring SYSTEM Temperature and Voltage with Auto Throttling Control	
Expansion	1 x Mini PCIe Support mSATA 1 x Optional 80-pin Expansion	
Storage	1 x 2.5" Drive Bay	
I/O		
USB	1 x USB 3.0, 3 x USB 2.0	
SATA	1 x SATA II	
Com Port	1 x RS-232/422/485 (Factory Optional) 1 x RS-232	
Other	3 x Knockouts for Antenna Mounting	
Display		
Chipset	Intel® Valleyview SoC integrated Graphics Supports optional dual display	
Resolution	HDMI: Max. resolution 1920x1200 @ 60Hz (by IET module)	

ARC-1209/1509

Dual Display	HDMI + LVDS	
Audio		
Audio Codec	Realtek ALC892	
Audio Interface	Speaker Out	
Speaker Output	2 x 2W	
Ethernet		
Chipset	2 x Intel® I210IT (A Model) 2 x Intel® I2101AT (B Model)	
Ethernet Interface	10/100/1000 Base-Tx GbE compatible	
Lan Port	2 x RJ-45	
Power Requirement		
Power Connector	Lockable DC Jack	
Power Requirement	+12V ~ +26V	
Power Type	AT/ATX (ATX is default setting)	
Adapter	Input: 100 ~ 240Vac/ 50 ~ 60Hz Output: 60W Adapter (12V @ 5A Adapter)	
Mechanical & Environmental		
System Fan	Fanless	
Construction - Front	Silver Aluminum	
Construction – Rear	Black	
Dimension	284 x 223 x 46 mm (A Model) 294 x 226.3 x 51 mm (B Model)	350 x 274 x 49.8 mm (A Model) 350.5 x 274.5 x 53 mm (B Model)
Weight	2.4 Kgs	3.7 Kgs
Operating Temperature	-20°C ~ 60°C (-4°F ~ 140°F) (A Model) -10C ~ 50°C (-14°F ~ 122°F) (B Model)	
Storage Temperature	-30°C ~ 70°C (-22°F ~ 158°F)	
Operating Humidity	0% ~ 90% Relative Humidity, Non-condensing	
Vibration Test	ARC-1209 (A Model) With SSD/mSATA : 5Grms, IEC 60068-2-64, Random, 5 ~ 500Hz, 1hr/axis ARC-1209 (B Model)/ ARC-1509 (A/B Model) With SSD/mSATA : 3Grms, IEC 60068-2-64, Random, 5 ~ 500Hz, 1hr/axis	
Shock Test	Operating with SSD/CFast/mSATA : MIL-STD-810G, Method 516.6, Procedure I, functional shock=20G	
Certifications	CE, FCC Class B	
OS Information	Win 7, Win 8, Win 10, Linux	
Ordering Information/ Description		
ACC-ARC-USB-1R	4 x USB3.0 (ARC-BYT DB-A)	

ACC-ARC-AUDIO-1R	HDMI + Audio/Line out, Line in, Mic in (ARC-BYT DB-B)
ACC-ARC-MPCIE-1R	HDMI + Mini PCIe w/ SIM slot (ARC-BYT DB-C)
ACC-ARC-COM-1R	2 x Isolated RS-232 / 2kv (ARC-BYT DB-D)
ACC-ARC-COM-2R	3 x RS-232 (ARC-BYT DB-G)
ACC-ARC-COM-3R	2 x RS-232 + USB 2.0 (ARC-BYT DB-H)
ACC-ARC-COM-4R	2 x RS-232 + LAN (ARC-BYT DB-K)
ACC-ARC-GPIO-1R	12-bit GPIO + 2-pin CAN Bus Kit for ARC Series
ACC-ARC-OBDII-1R	OBDII - CAN Bus Kit for ARC Series (Small Vehicle)
ACC-ARC-OBDII-2R	OBDII - CAN Bus Kit for ARC Series (Large Vehicle)
ACC-ARC-OBDII-3R	OBDII - CAN Bus Kit for ARC Series (Special Large Vehicle)



Note: Specifications are subject to change without notice.

1.4 System Overview

1.4.1 I/O View

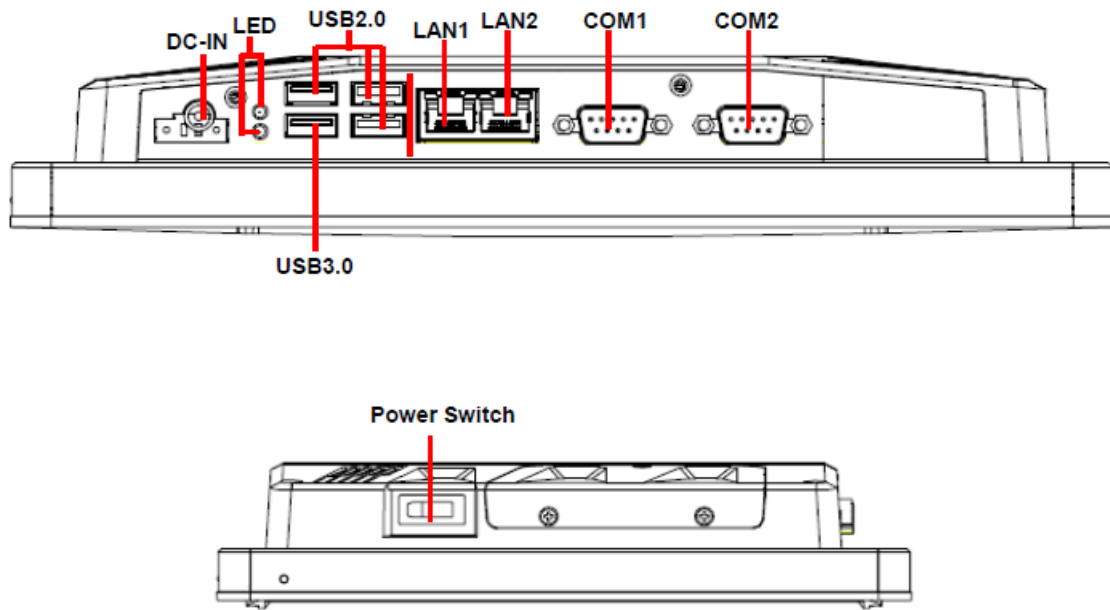

Connectors

Label	Function	Note
DC-IN	DC Power-in connector	Default: Lockable DC Jack Option: Phoenix Connector(MOQ apply)
COM1/2	Serial port 1/2 connector	DB-9 male connector
USB	3 x USB 2.0 connector 1 x USB 3.0 connector	
LAN1/2	RJ-45 Ethernet 1/2	
LED	HDD/Power LED indicator	
Power Switch	Power on button	

1.5 System Dimensions

1.5.1 ARC-1209 (A Model)

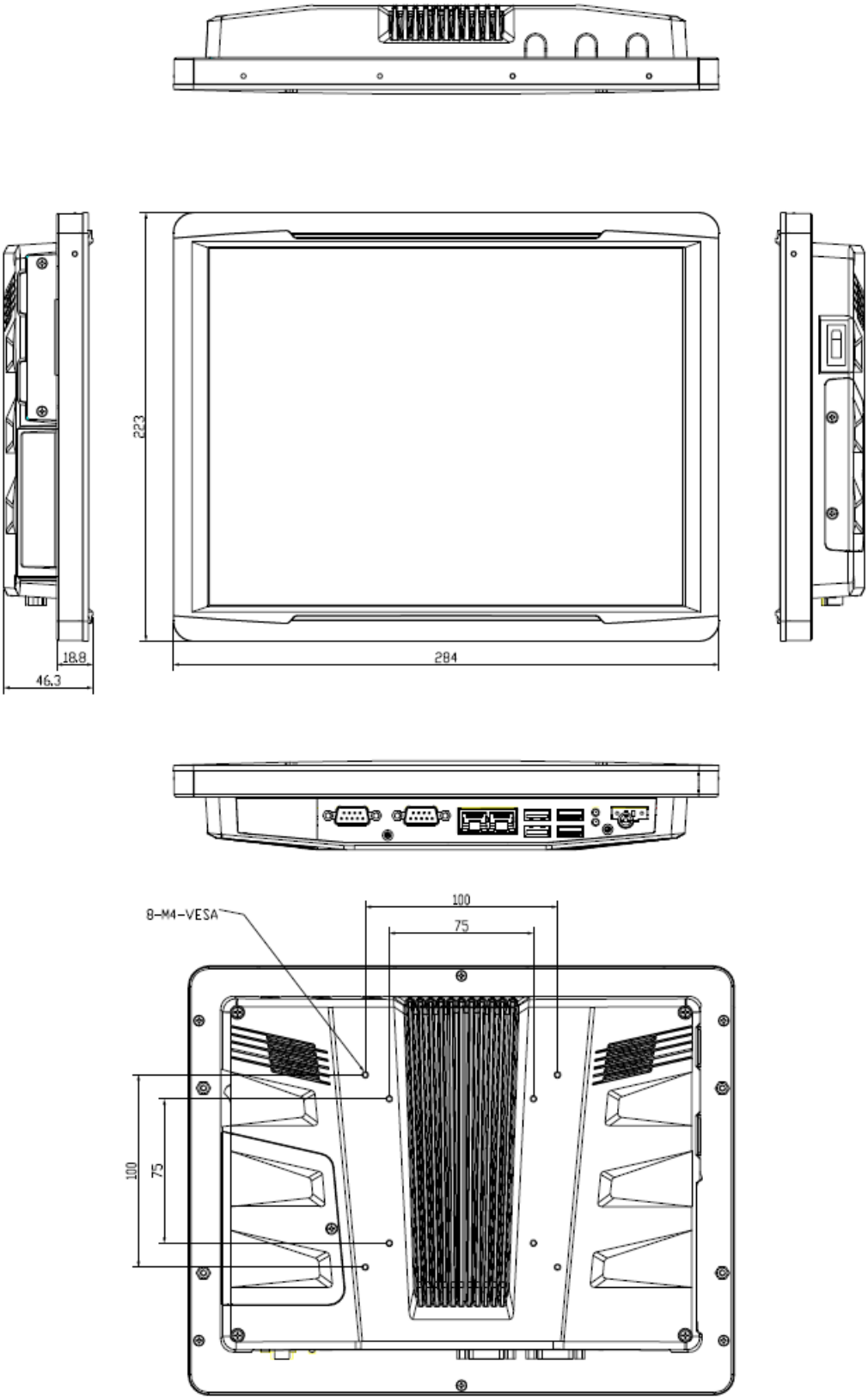

(Unit: mm)

ARC-1209/1509

1.5.2 ARC-1209 (B Model)

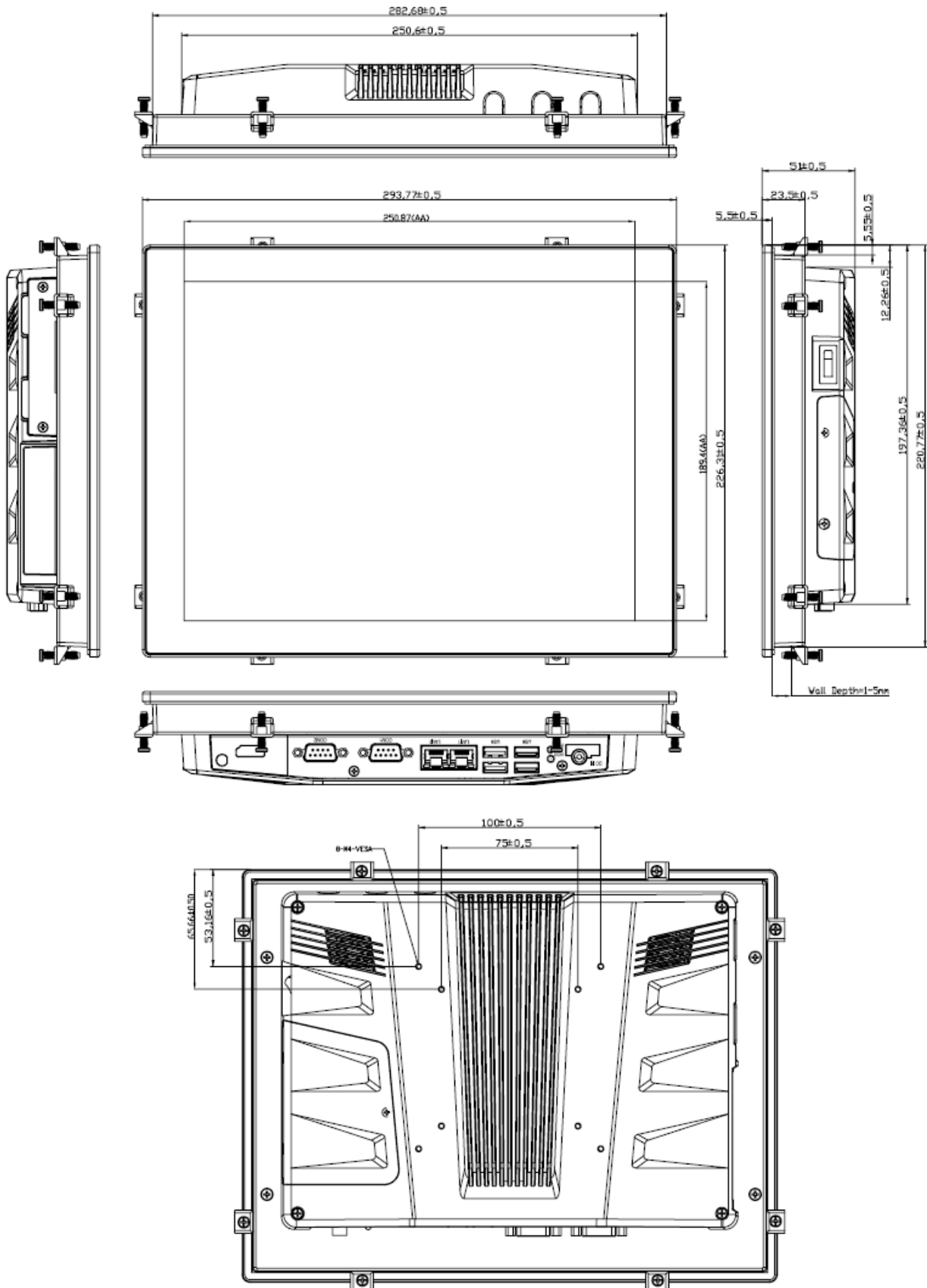

(Unit: mm)

1.5.3 ARC-1509 (A Model)

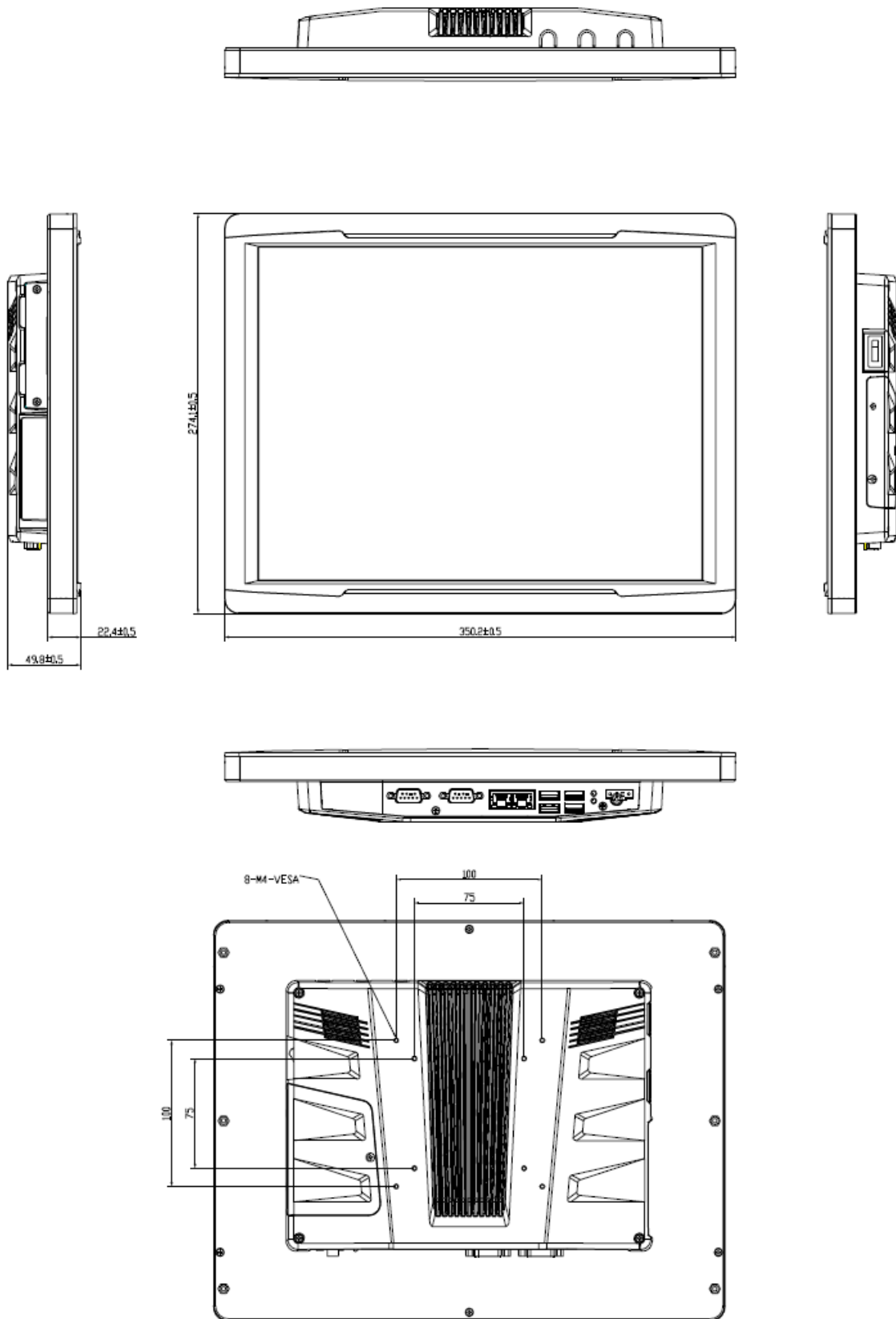

(Unit: mm)

ARC-1209/1509

1.5.4 ARC-1509 (B Model)

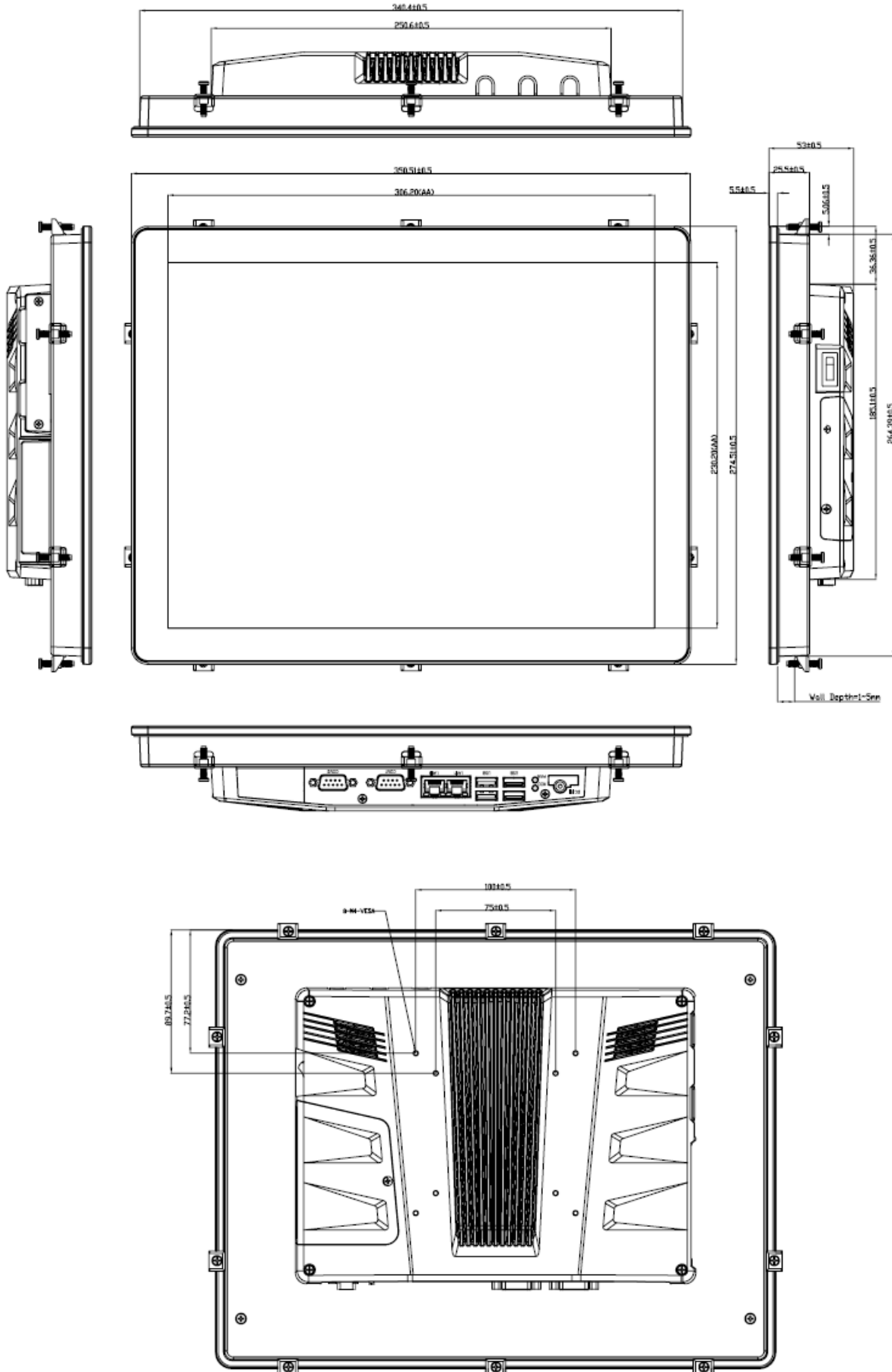

(Unit: mm)

2. Hardware Configuration

For advanced information, please refer to:

- 1- ARC-BYT, ARC-BYT DB-A/B/C/D/E/F/G/H/K included in this manual.

2.1 ARC-1209/1509 connector mapping

2.1.1 Serial port 1 connector (COM1)

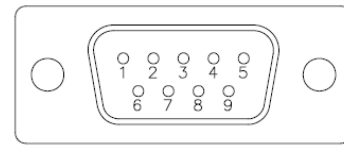
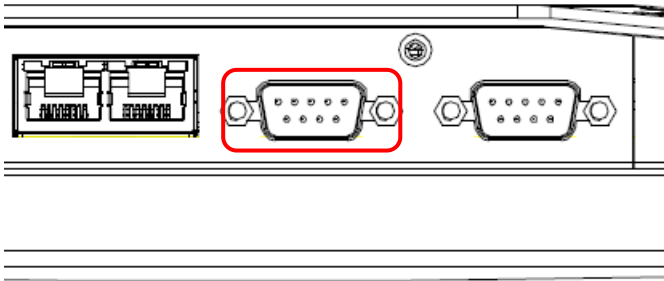

RS-232

Signal	PIN	PIN	Signal
NDCDA#	1	6	NDSRA#
NRXDA	2	7	NRTSA#
NTXDA	3	8	NCTSA#
NDTRA#	4	9	NRIA#
GND	5		

RS-485

Signal	PIN	PIN	Signal
DATA-	1	6	NC
DATA+	2	7	NC
NC	3	8	NC
NC	4	9	NC
GND	5		

RS-422

Signal	PIN	PIN	Signal
TxD-	1	6	NC
TxD+	2	7	NC
RxD+	3	8	NC
RxD-	4	9	NC
GND	5		

2.1.2 Serial port 2 connector (COM2)

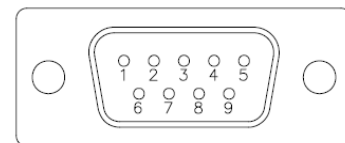
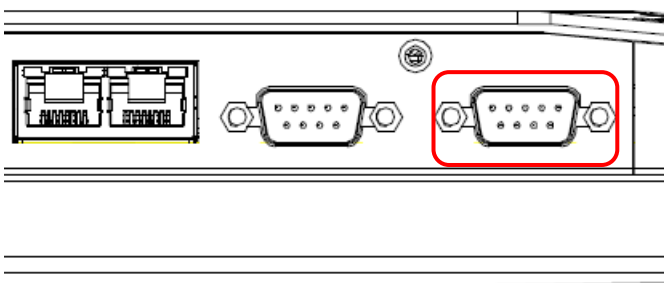

Signal	PIN	PIN	Signal
NDCDB#	1	6	NDSRB#
NRXDB	2	7	NRTSB#
NTXDB	3	8	NCTSB#
NDTRB#	4	9	NRIB#
GND	5		

2.2 Installing Hard Disk & Memory

Step 1. Memory Installation: Remove 3 screws to release the chassis cover, and remove it.

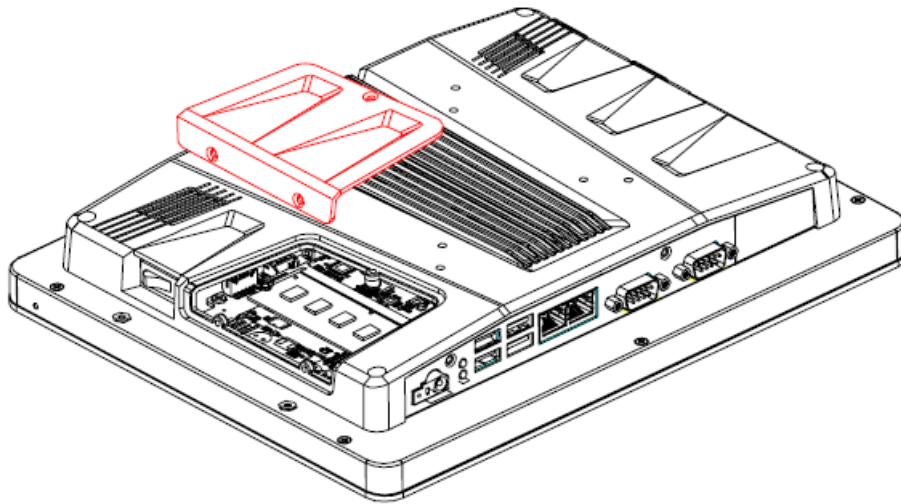
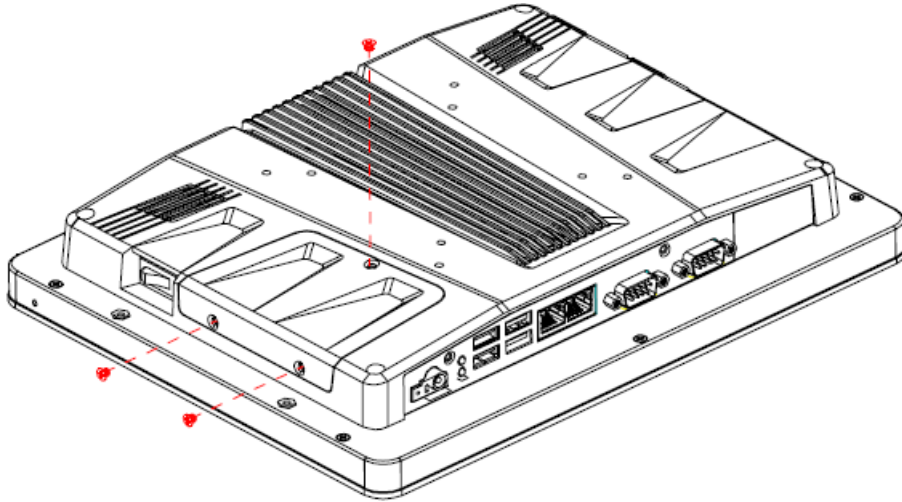

Step 2.1 Insert the SODIMM into the memory socket.

Step 2.2 Re-assemble your system back through previous steps to complete the installation.

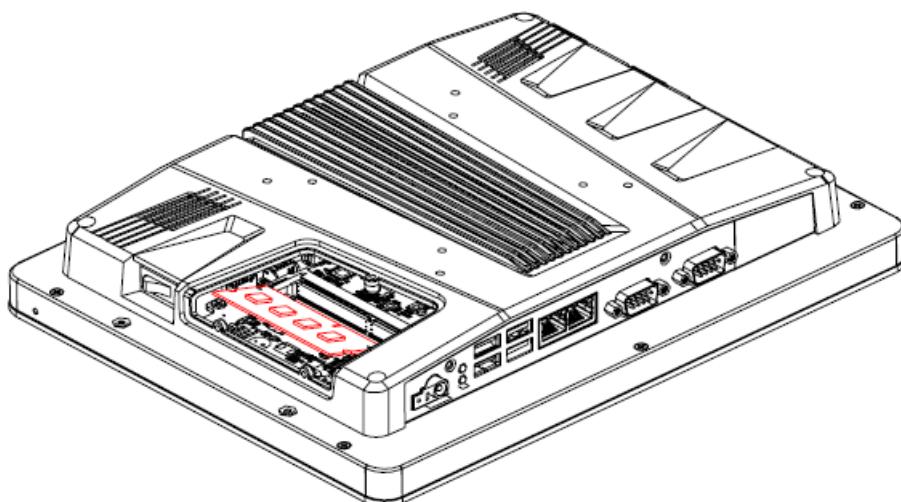

Step 3. HDD Installation: Insert the HDD into the Drive Bay and fasten 2 screws.

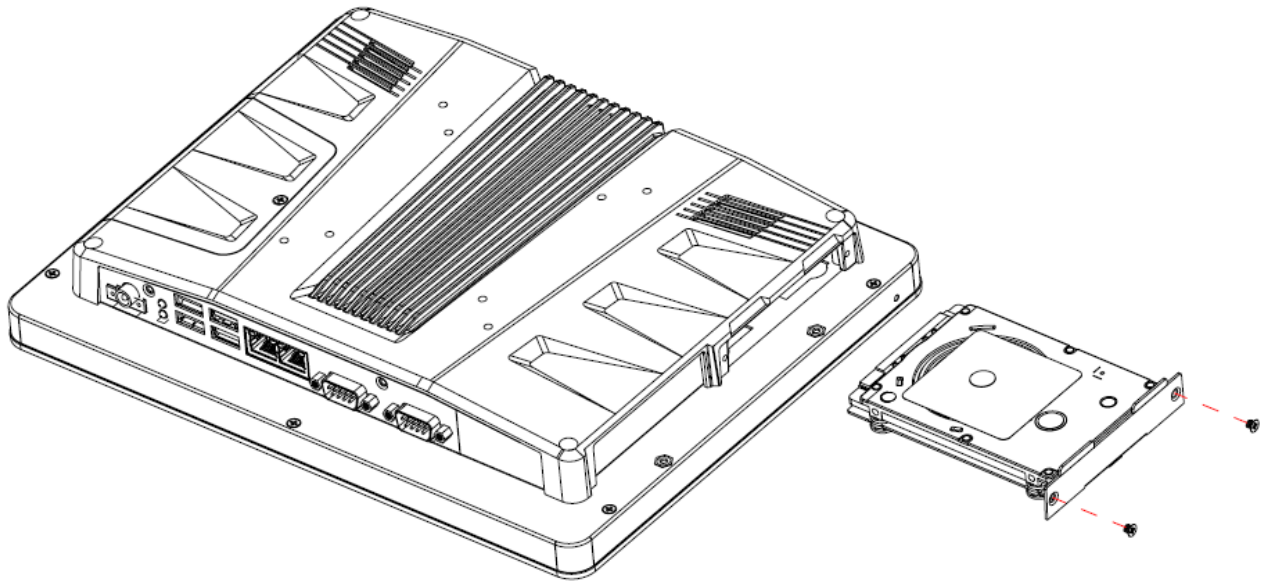

2.3 Installing ARC-BYT DB

Step 1. Unfasten 2 screws of the HDD bracket and take it off.

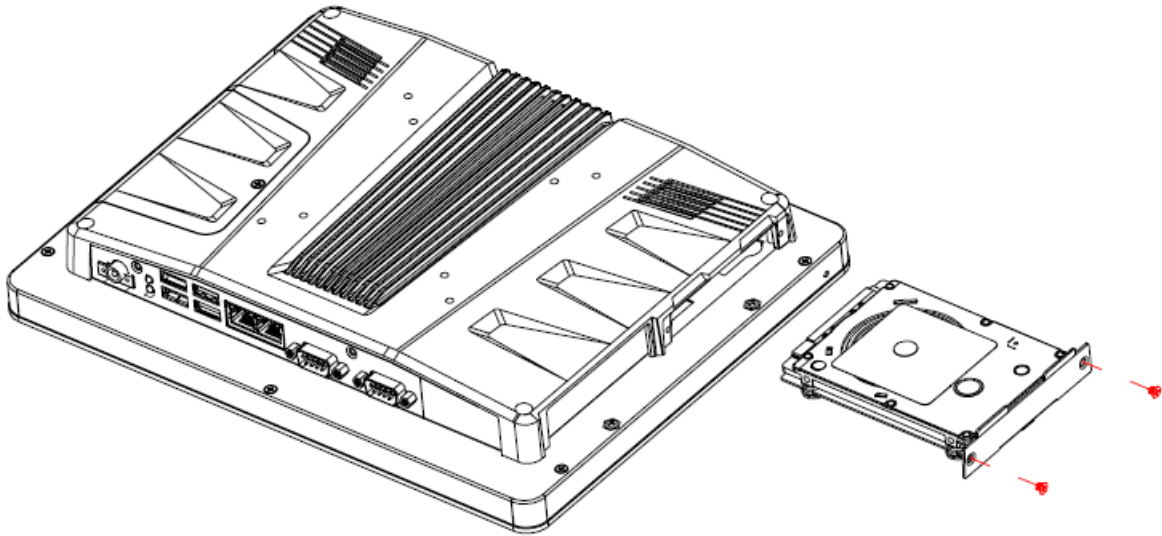

Step 2. Remove 4 screws to release the chassis cover, and remove it.

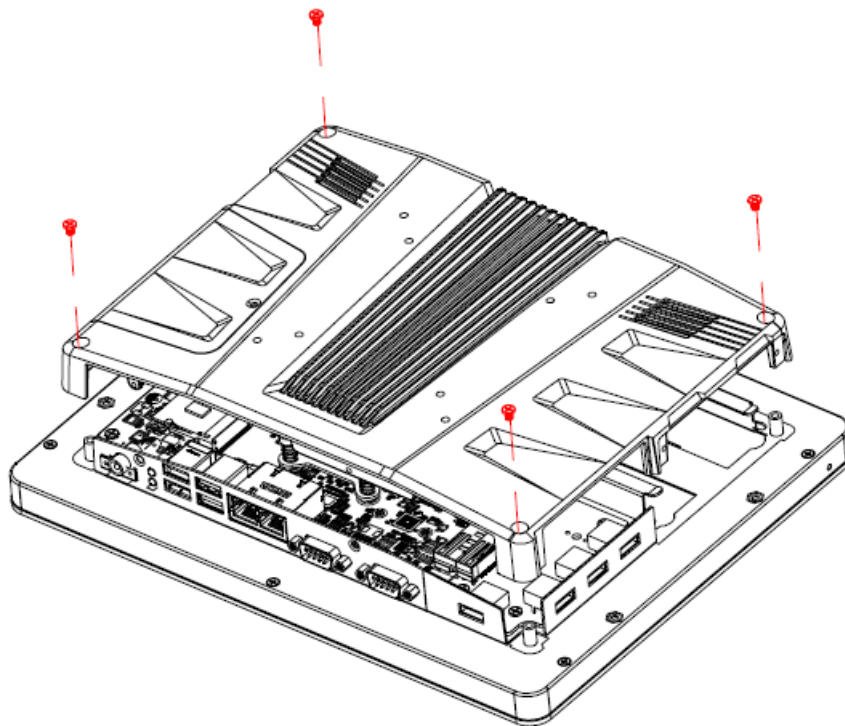

ARC-1209/1509

Step 2.1 Insert the ARC-BYT DB into the socket and fasten 3 screws.

Step 2.2 Re-assemble your system back through previous steps to complete the installation

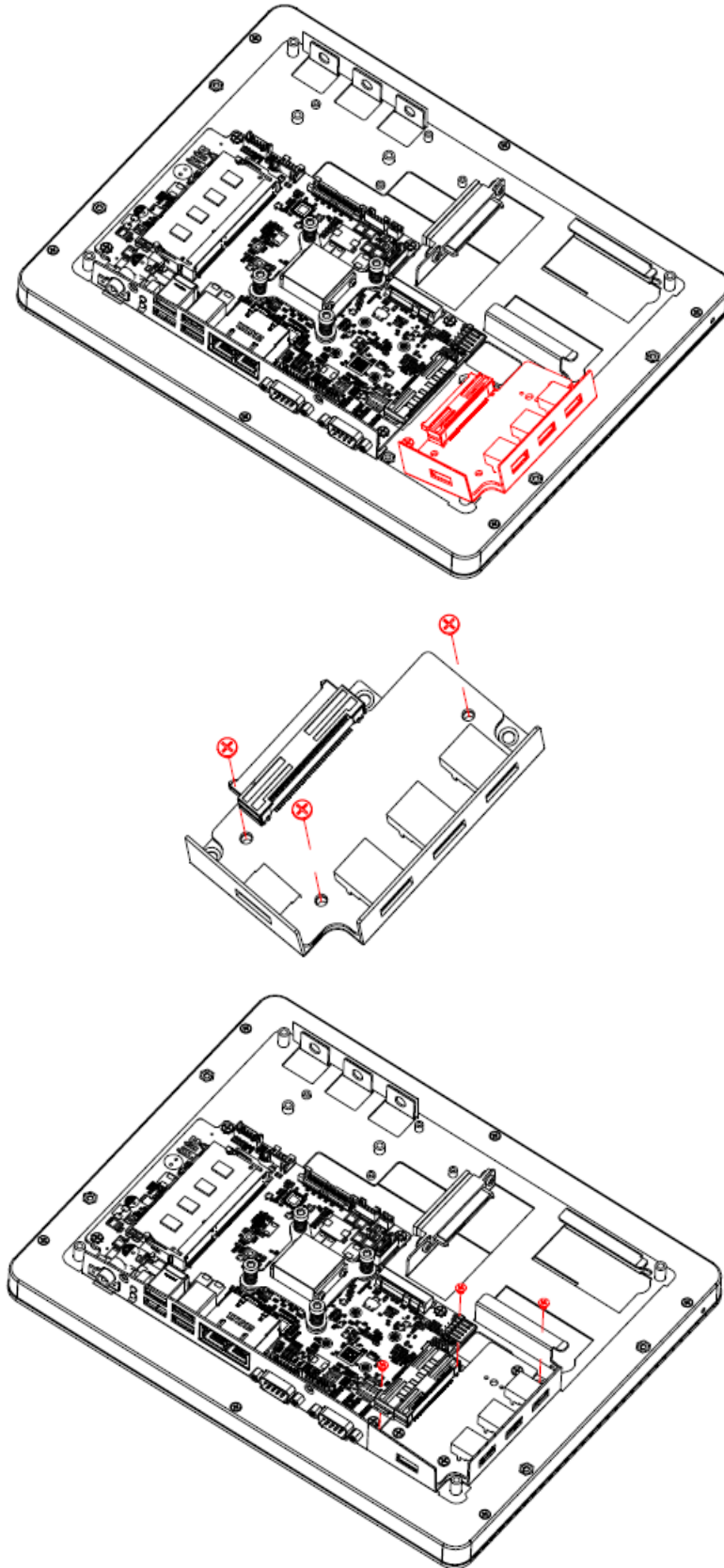

2.4 ARC-BYT Overviews

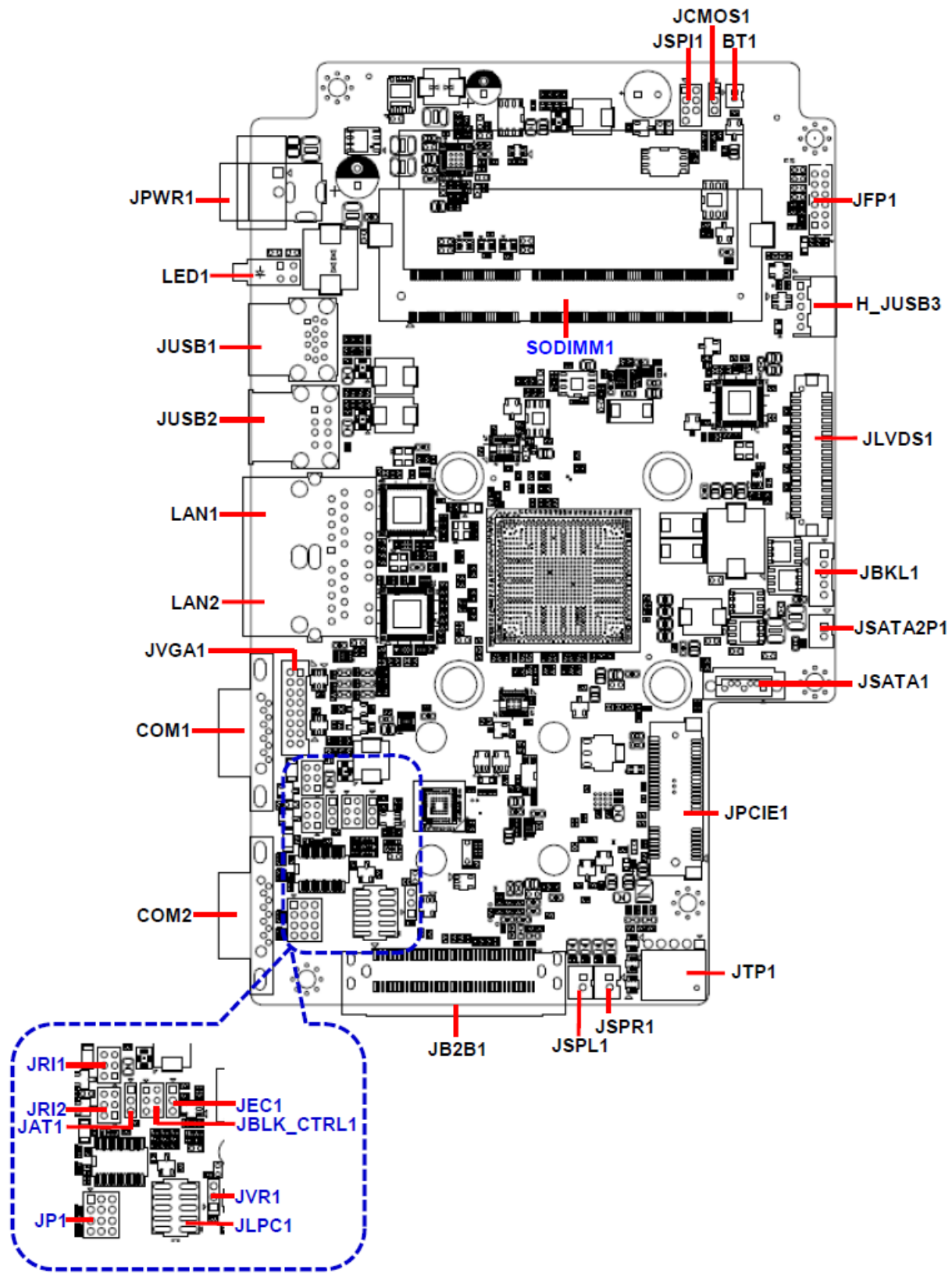

2.5 ARC-BYT Jumper and Connector list

Jumper

Label	Function	Note
JCMOS1	Clear CMOS	3 x 1 header, pitch 2.00mm
JRI1/2	Serial port 1/2 pin9 signal select	3 x 2 header, pitch 2.00mm
JP1	Serial port 1 in RS-422/485 mode	4 x 3 header, pitch 2.00mm
JVR1	LCD backlight brightness adjustment	3 x 1 header, pitch 2.00mm
JAT1	AT/ATX Input power select	3 x 1 header, pitch 2.00mm

Connectors

Label	Function	Note
SODIMM1	204-pin DDR3L SODIMM socket	
JBKL1	LCD Inverter connector	5 x 1 wafer, pitch 2.00mm
COM1/2	Serial Port 1/2 connector	D-sub 9 pin, male
JTP1	Touch panel connector	5 x 1 header, pitch 2.54mm
JSPR1	AMPLIFIER_R	2 x 1 wafer, pitch 2.00mm
JSPL1	AMPLIFIER_L	2 x 1 wafer, pitch 2.00mm
JB2B1	B2B connector	40 x 2 wafer, pitch 0.80mm
JBLK_CTRL1	LCD backlight brightness adjustment	3 x 2 header, pitch 2.00 mm
LED1	HDD/Power LED indicator	
JLVDS1	LVDS connector	DIN 40-pin wafer, pitch 1.25mm
JUSB1/2	USB connector 1/2	
LAN1/2	RJ-45 Ethernet 1/2	
JPCIE1	PCI Express connector	
JFP1	Miscellaneous setting connector	6 x 2 wafer, pitch 2.00 mm
BT1	Battery connector	2 x 1 wafer, pitch 1.25mm
H_JUSB3	On-board header for USB2.0	5 x 2 wafer, pitch 2.00 mm
JLPC1	LPC connector	5 x 2 header, pitch 2.00mm
JPWR1	Power connector	
JSPI1	SPI connector	4 x 2 header, pitch 2.00mm
JEC1	EC Debug connector	3 x 1 header, pitch 2.00 mm
JSATA1	Serial ATA connector	
JSATA2P1	SATA Power connector	2 x 1 wafer, pitch 2.00mm
JVGA1	VGA connector	8 x 2 wafer, pitch 2.00 mm

2.6 ARC-BYT Jumpers & Connectors settings

2.6.1 Clear CMOS (JCMOS1)

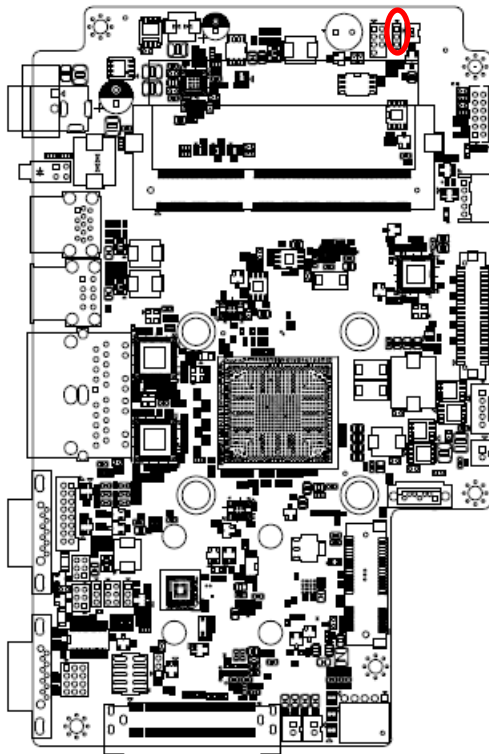

Protect*

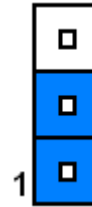

1

Clear CMOS

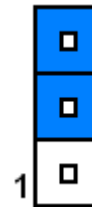

1

*Default

2.6.2 Serial port 1/2 pin9 signal select (JRI1/JRI2)

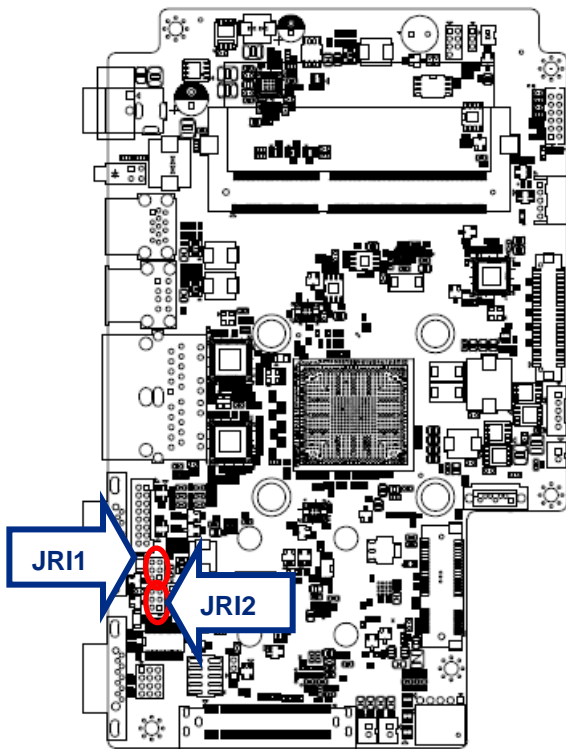

Ring*

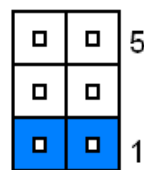

5

1

+12V

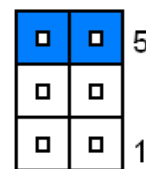

5

1

+5V

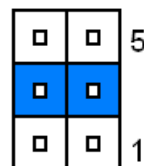

5

1

* Default

2.6.3 LCD backlight brightness adjustment (JVR1)

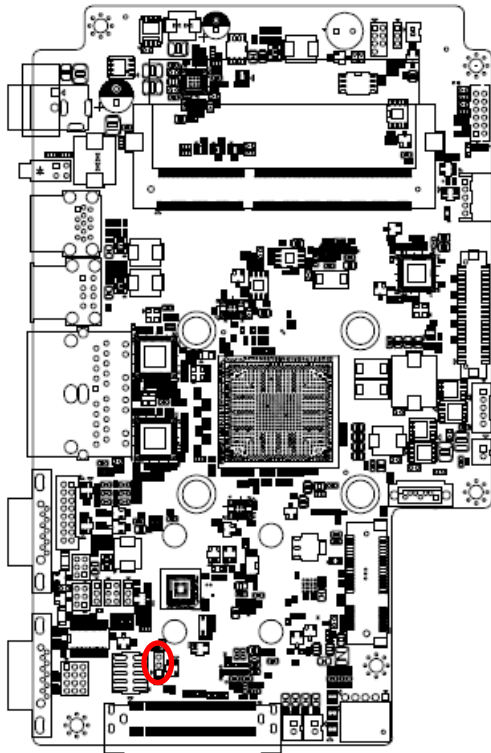

PWM Mode*

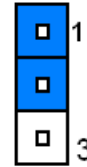

DC Mode

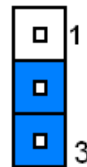

* Default

2.6.4 AT/ATX Input power select (JAT1)

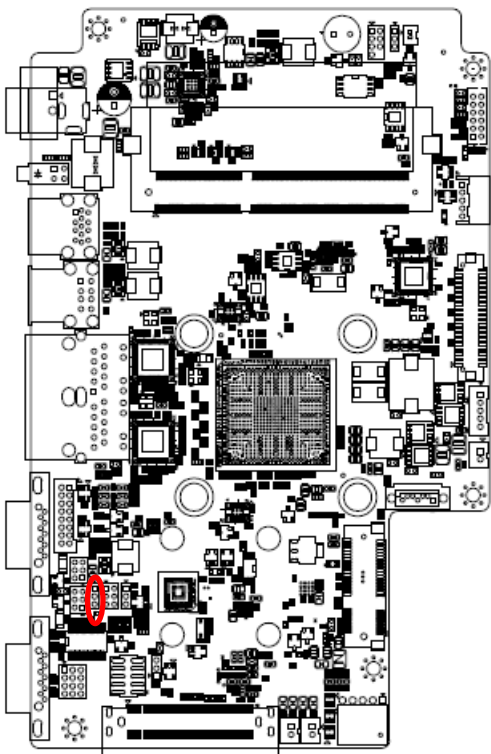

ATX*

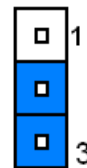

AT

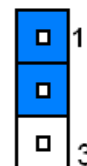

* Default

2.6.5 Serial port 1 in RS-422/485 mode (JP1)

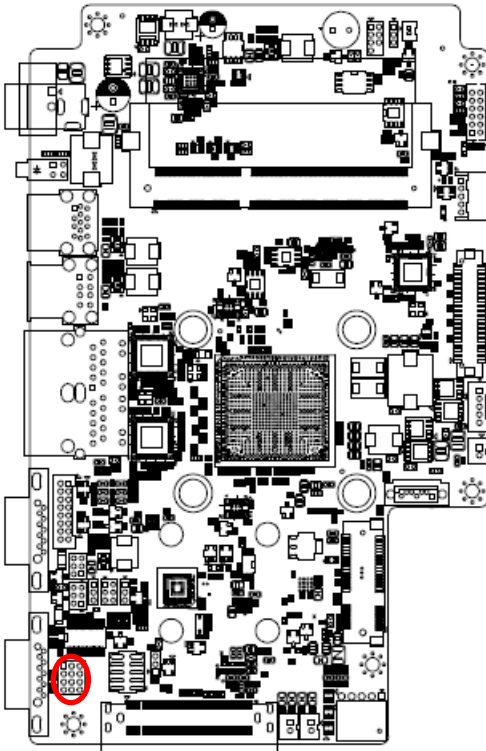

For RS-232*

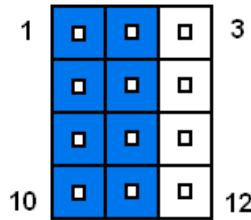

For RS-422/485

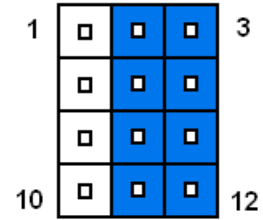

PIN	Signal	PIN	Signal	PIN	Signal
1	NDCDA#	2	COM1-1	3	485_422TX1-
4	NRXDA	5	COM1-2	6	485_422TX1+
7	NTXDA	8	COM1-3	9	422RX1+
10	NDTRA#	11	COM1-4	12	422RX1-

* Default

2.6.6 LCD Inverter connector (JBKL1)

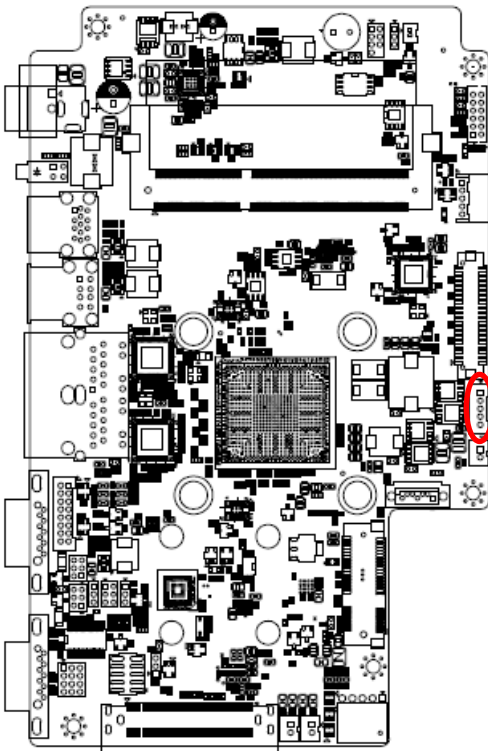

Signal	PIN
+12V	1
GND	2
BKLEN	3
VBRIGHT	4
+5V	5

Note:



For inverters with adjustable Backlight function, it is possible to control the LCD brightness through the VR signal controlled by JVR. Please see the JVR section for detailed circuitry information.

2.6.7 On-board header for USB2.0 (H_JUSB3)

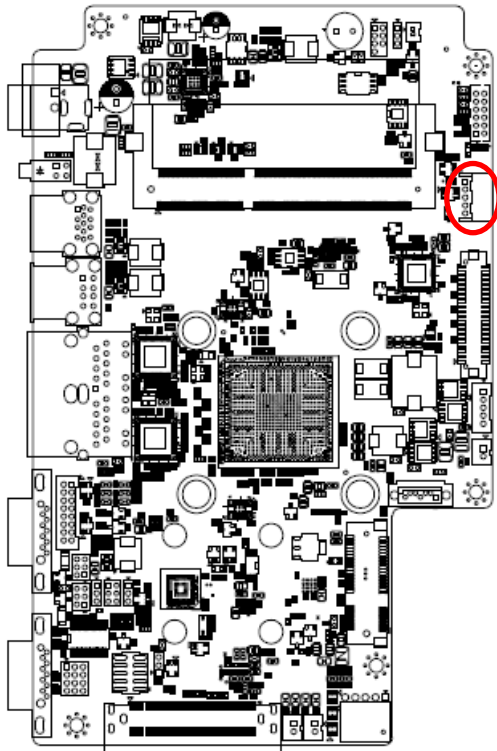

Signal	PIN
USBVCC4	1
USB_DN_R_5	2
USB_DP_R_5	3
GND	4
GND	5

2.6.8 SATA Power connector (JSATA2P1)

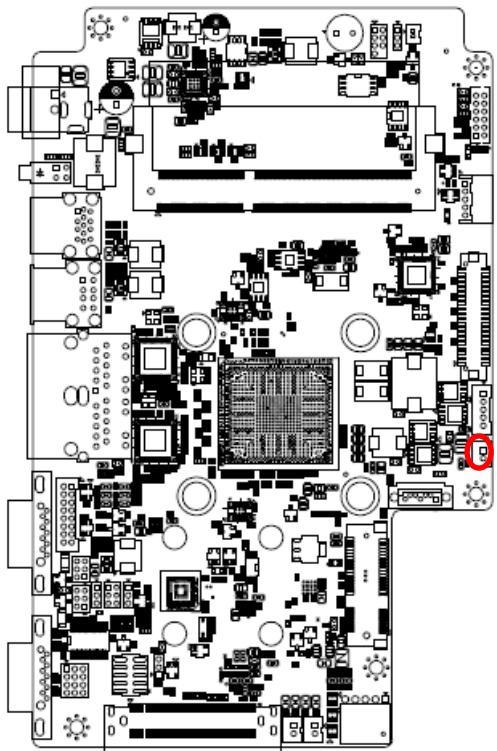

Signal	PIN
GND	1
+5V	2

2.6.9 LVDS connector (JLVDS1)

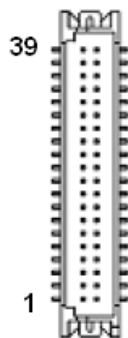
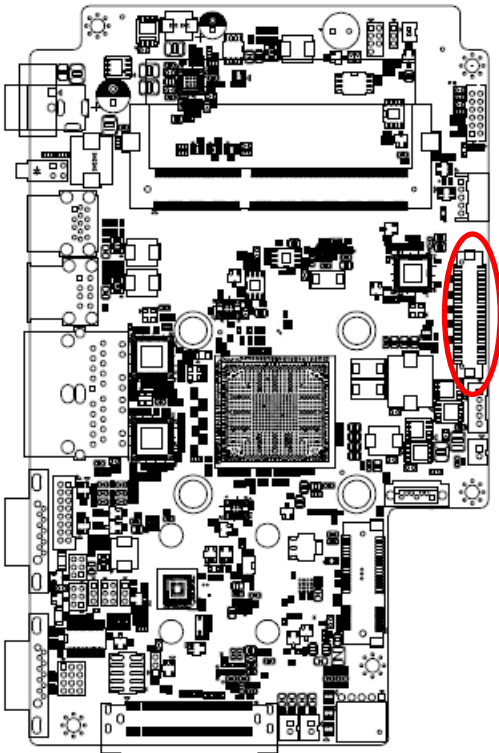

Signal	PIN	PIN	Signal
+12V	39	40	+12V
GND	37	38	GND
LVDS_CLK2_N	35	36	LVDS_CLK1_N
LVDS_CLK2_P	33	34	LVDS_CLK1_P
GND	31	32	GND
LVDS_DATA7_N	29	30	LVDS_DATA6_N
LVDS_DATA7_P	27	28	LVDS_DATA6_P
GND	25	26	GND
LVDS_DATA5_N	23	24	LVDS_DATA4_N
LVDS_DATA5_P	21	22	LVDS_DATA4_P
GND	19	20	GND
LVDS_DATA3_N	17	18	LVDS_DATA2_N
LVDS_DATA3_P	15	16	LVDS_DATA2_P
GND	13	14	GND
LVDS_DATA1_N	11	12	LVDS_DATA0_N
LVDS_DATA1_P	9	10	LVDS_DATA0_P
GND	7	8	GND
NC	5	6	NC
+3.3V	3	4	+5V
+3.3V	1	2	+5V

2.6.10 Battery connector (BT1)

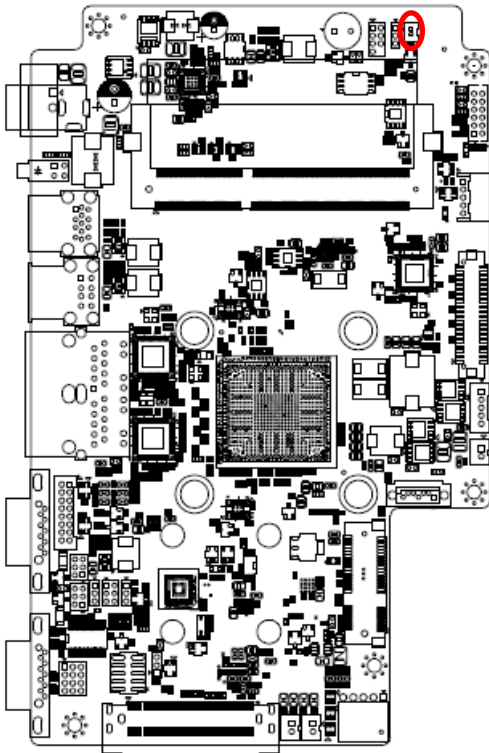

Signal	PIN
+3.3VSB	1
GND	2

2.6.11 AMPLIFIER_R (JSPR1)

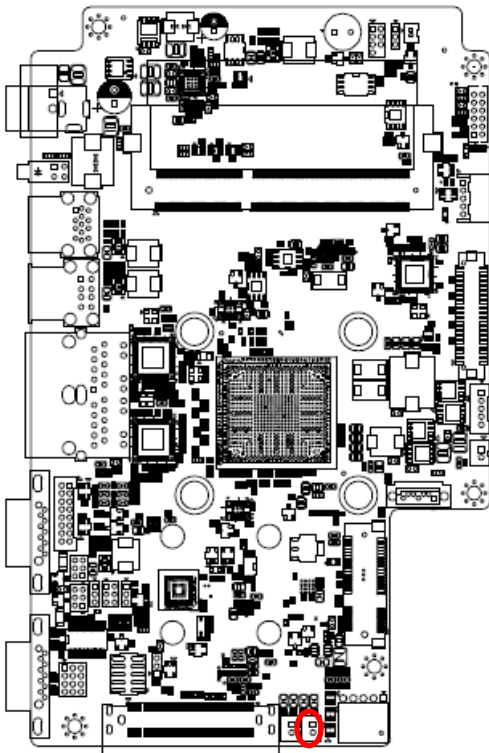

Signal	PIN
SPK_R+	1
SPK_R-	2

2.6.12 AMPLIFIER_L (JSPL1)

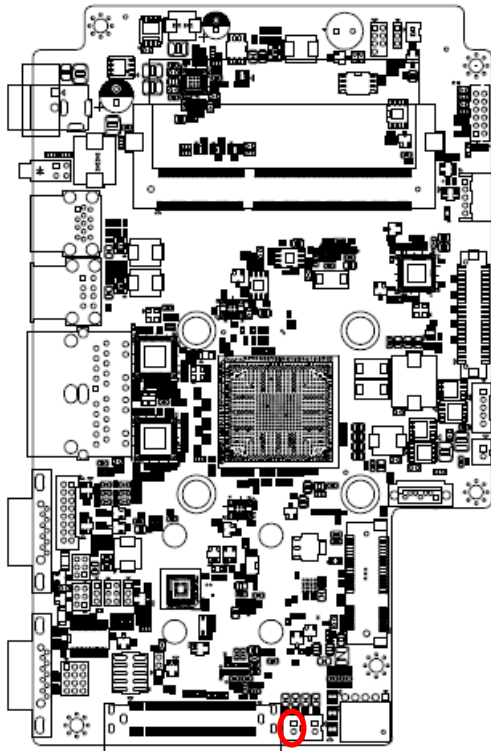

Signal	PIN
SPK_L+	1
SPK_L-	2

2.6.13 LPC connector (JLPC1)

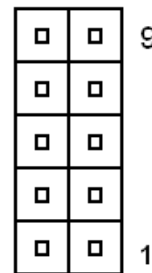
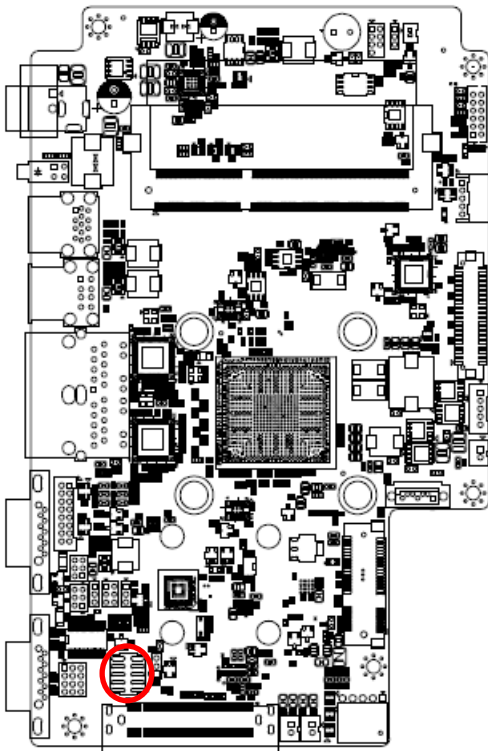

Signal	PIN	PIN	Signal
GND	10	9	LPC_SERIRQ
LPC_PORT80_CLK	8	7	LPC_AD3
LPC_FRAME#	6	5	LPC_AD2
LPC_PORT80_RST#	4	3	LPC_AD1
+3.3V	2	1	LPC_AD0

2.6.14 SPI connector (JSPI1)

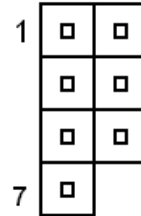
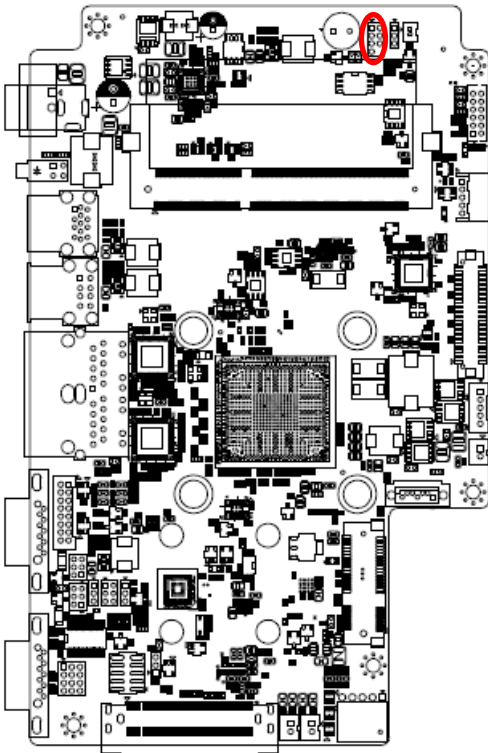

Signal	PIN	PIN	Signal
+VSPI_BIOS	1	2	GND
SPI_ROM_CS#	3	4	SPI_ROM_CLK
SPI_ROM_MISO_R	5	6	SPI_ROM_MOSI
SPI_HOLD#	7		

2.6.15 EC_Program (JEC1)

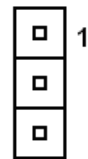
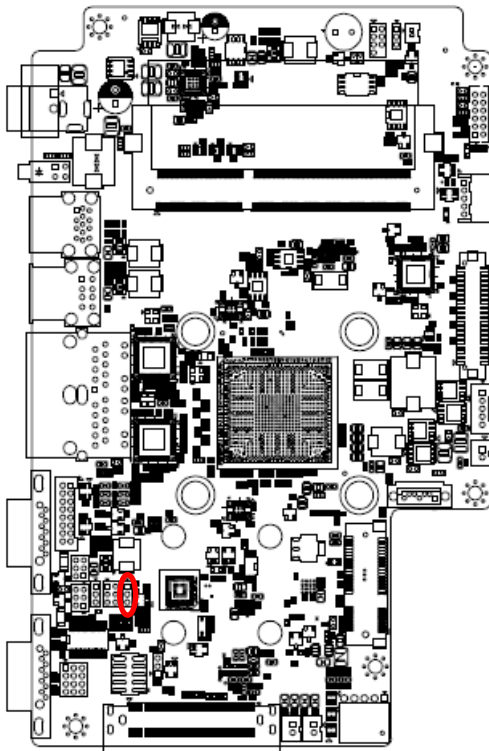

Signal	PIN
EC_SMCLK_DEBUG	1
EC_SMDAT_DEBUG	2
GND	3

2.6.16 Miscellaneous setting connector (JFP1)

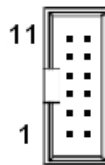
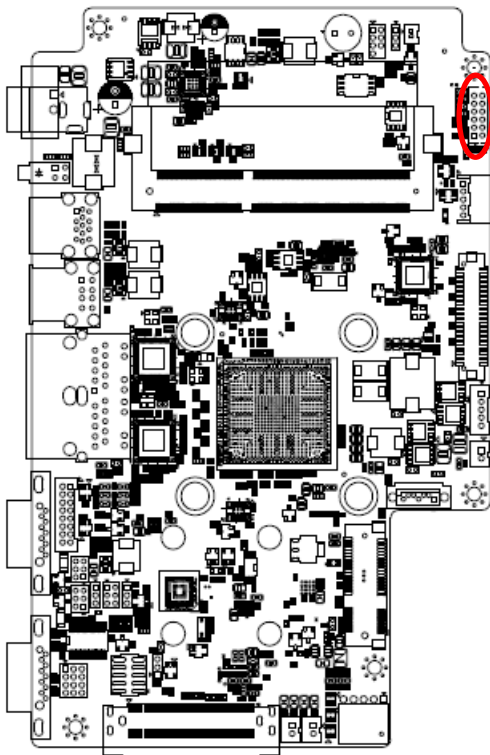

Signal	PIN
PWBT	1
	2
RST#	3
	4
PWR-LED-	5
PWR-LED+	6
HDD-LED-	7
HDD-LED+	8
LAN1-LED-	9
LAN1-LED+	10
LAN2-LED-	11
LAN2-LED+	12

2.6.17 LCD backlight brightness adjustment (JBLK_CTRL1)

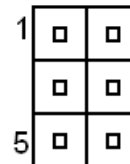
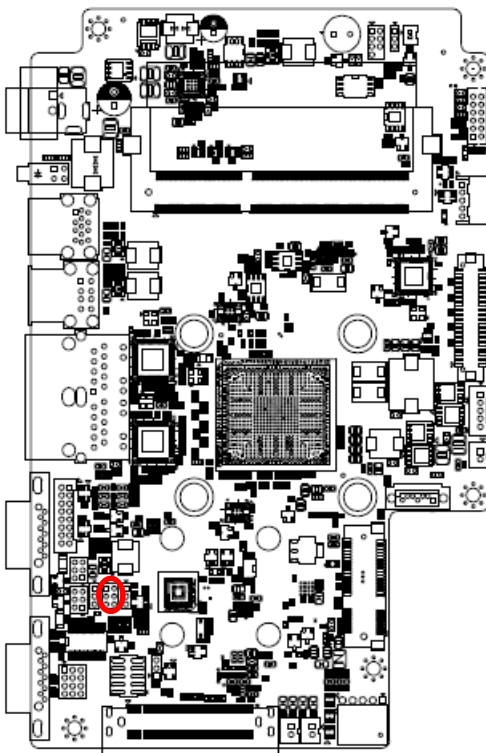

PIN	Signal	Note
1-2	BLK_VR_MOD	VR must select 10K/1%
3-4	BLK_BRI_UP	Low pulse button for backlight brighter
5-6	BLK_BRI_DN	Low pulse button for backlight dim

2.6.18 B2B connector (JB2B1)

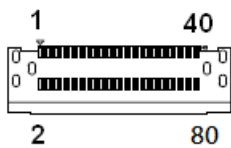
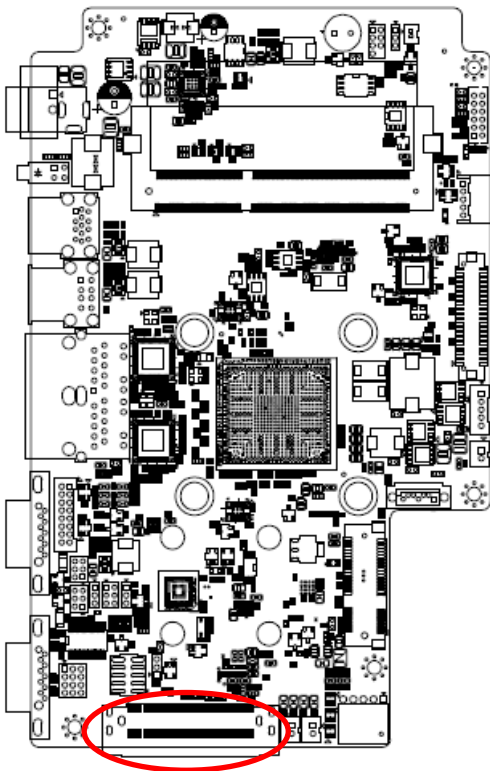

Signal	PIN	PIN	Signal
GND	1	41	GND
GND	2	42	GND
+12VSB	3	43	GND
+12VSB	4	44	GND
GND	5	45	GND
LPC_SERIRQ	6	46	+5VSB
LPC_FRAME#	7	47	+5VSB
LPC_COM_CLK1	8	48	+5VSB
LPC_AD0	9	49	+5VSB
LPC_AD1	10	50	+5VSB

Signal	PIN	PIN	Signal
LPC_AD2	11	51	GND
LPC_AD3	12	52	USB_DP4
PS_ON	13	53	USB_DN4
PLT_RST#	14	54	GND
SLP_S3#	15	55	SMB_CLK
HDMI_HPD	16	56	SMB_DATA
GND	17	57	GND
HDMI_SCLK_R	18	58	DIS_MPCIE
HDMI_SDATA_R	19	59	PONRSTB
GND	20	60	USB3-0_SMIB
DDI0_HDMI_TXN_2	21	61	PCIE_WAKE#_3
DDI0_HDMI_TXP_2	22	62	PEIE_RESET#_3
GND	23	63	PCIE_CLKREQ#_3
DDI0_HDMI_TXN_1	24	64	GND
DDI0_HDMI_TXP_1	25	65	PCIE_TXN_3
GND	26	66	PCIE_TXP_3
DDI0_HDMI_TXN_0	27	67	GND
DDI0_HDMI_TXP_0	28	68	PCIE_RXN_3
GND	29	69	PCIE_RXP_3
DDI0_HDMI_CLK_N	30	70	GND
DDI0_HDMI_CLK_P	31	71	PCIE_CLKN_3
GND	32	72	PCIE_CLKP_3
GND	33	73	GND
MIC_RIN	34	74	GND
MIC_LIN	35	75	MIC1_JD
GND	36	76	GND
LINEOUT1_JD	37	77	LINE1_JD
LINEOUT_R	38	78	LINE1_RIN
LINEOUT_L	39	79	LNE1_LIN
GND	40	80	GND

2.6.19 Touch panel connector (JTP1)

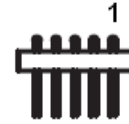
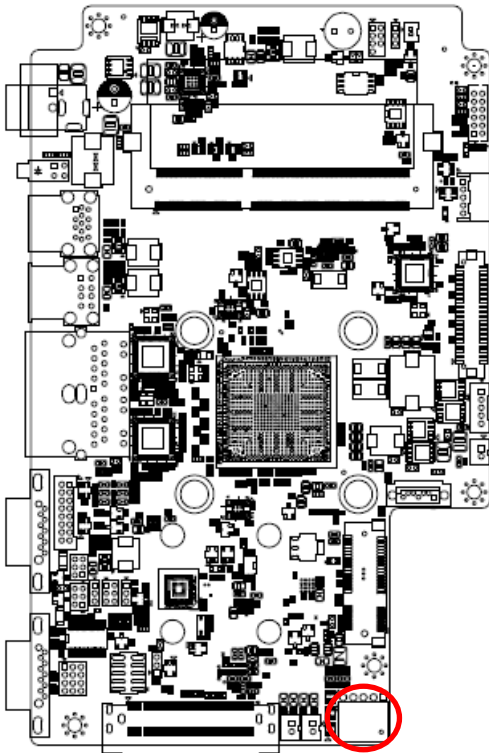

Signal	PIN
UL	1
UR	2
PROBE	3
LL	4
LR	5

2.6.20 Power connector (PWR1)

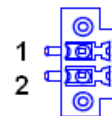
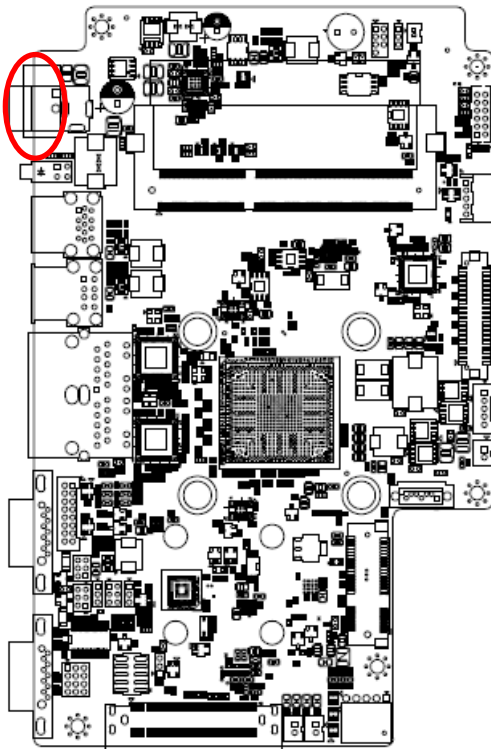

*Option: Phoenix Connector

Signal	PIN
+DCIN	1
GND	2

2.7 ARC-BYT DB-A/B/C/D/E/F/G/H/K Overviews

2.7.1 ARC-BYT DB-A

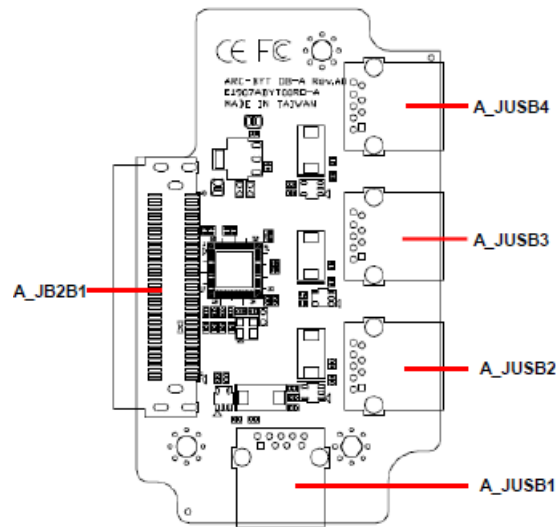

2.7.2 ARC-BYT DB-B

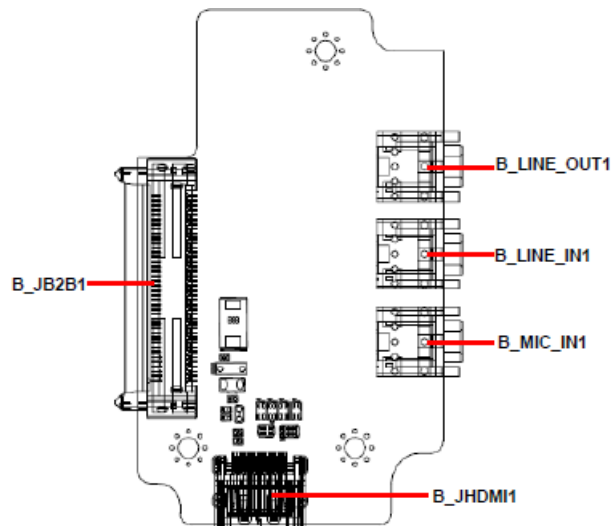

2.7.3 ARC-BYT DB-C

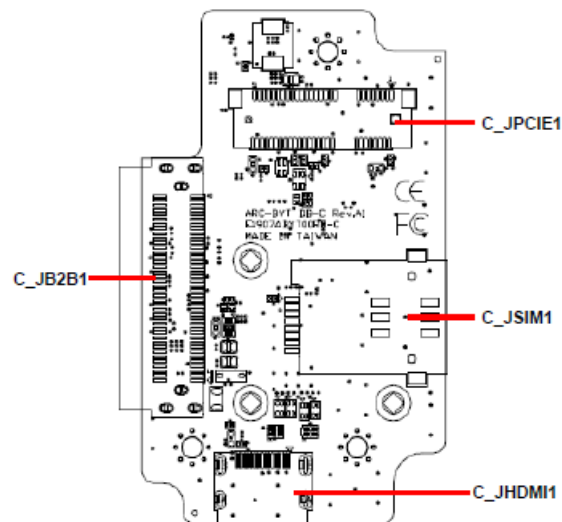

2.7.4 ARC-BYT DB-D

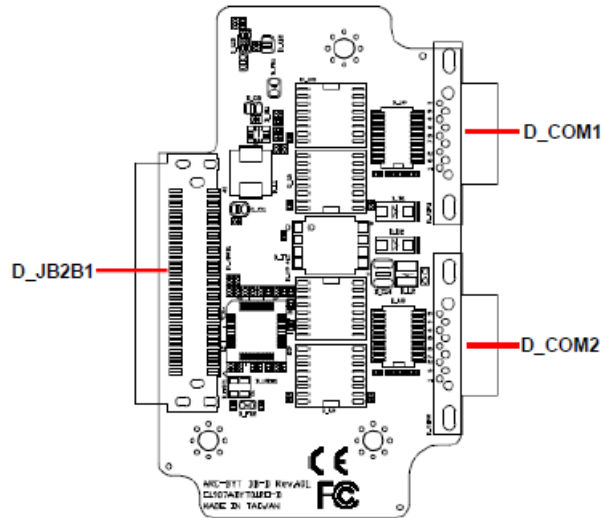

2.7.5 ARC-BYT DB-E

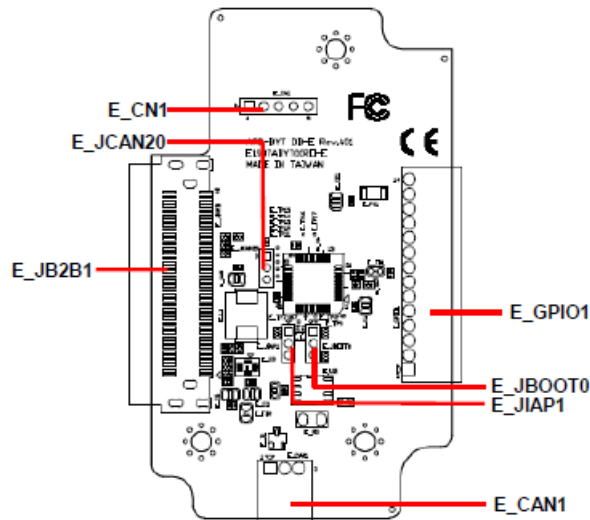

2.7.6 ARC-BYT DB-F

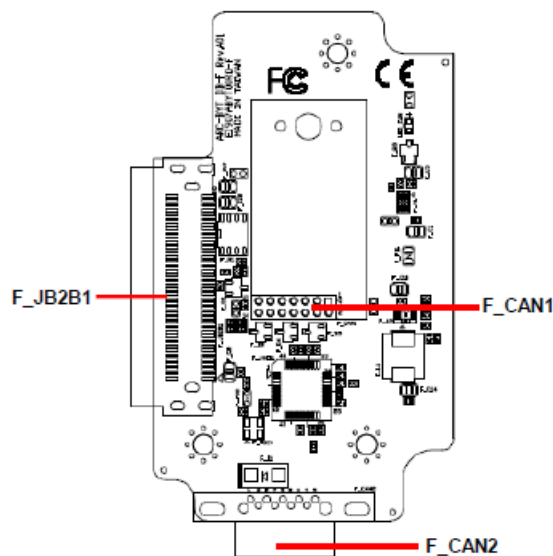

2.7.7 ARC-BYT DB-G

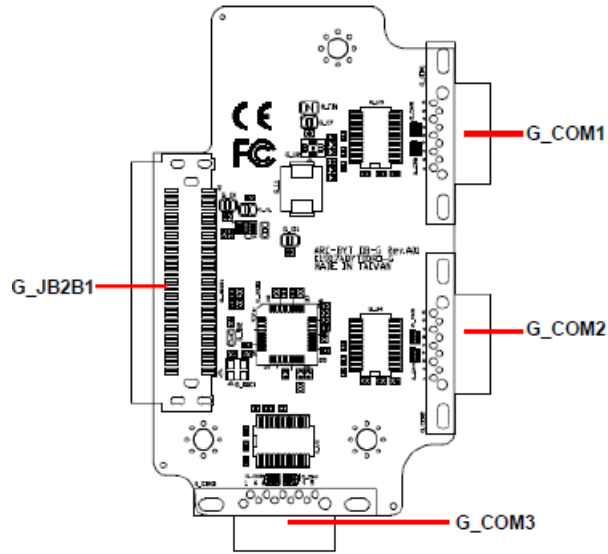

2.7.8 ARC-BYT DB-H

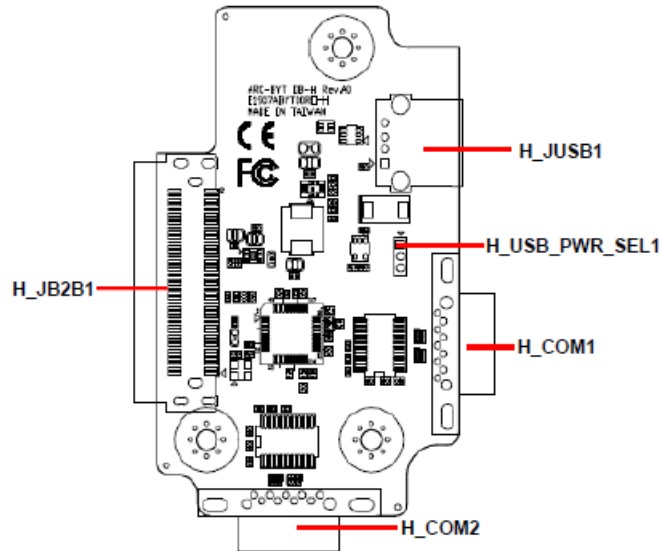

2.7.9 ARC-BYT DB-K

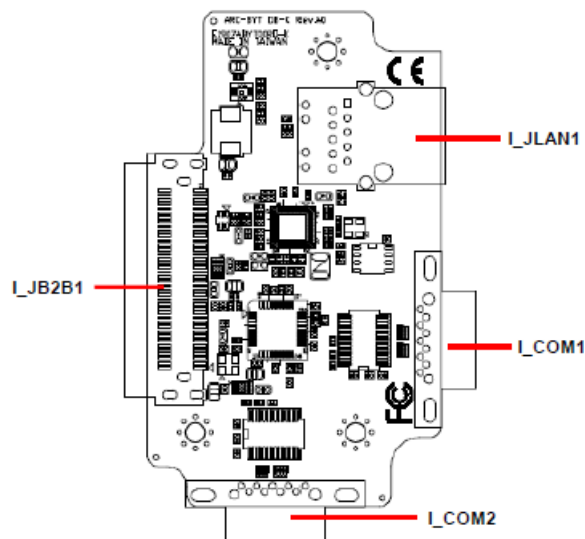

2.8 ARC-BYT DB-A/B/C/D/E/F/G/H/K Connector list

2.8.1 ARC-BYT DB-A

Connectors

Label	Function	Note
A_JUSB1~4	USB3.0 connector 1~4	
A_JB2B1	B2B connector	

2.8.2 ARC-BYT DB-B

Connectors

Label	Function	Note
B_LINE_OUT1	Line-out audio jack	
B_LINE_IN1	Line-in audio jack	
B_MIC_IN1	Mic-in audio jack	
B_JHDMI1	HDMI connector	
B_JB2B1	B2B connector	

2.8.3 ARC-BYT DB-C

Connectors

Label	Function	Note
C_JPCIE1	Mini PCI Express connector	
C_JSIM1	SIM card slot (Push-push)	
C_JHDMI1	HDMI connector	
C_JB2B1	B2B connector	

2.8.4 ARC-BYT DB-D

Connectors

Label	Function	Note
D_COM1/2	Serial Port 1/2 connector	DB-9 male connector
D_JB2B1	B2B connector	

2.8.5 ARC-BYT DB-E

Jumpers

Label	Function	Note
E_JCAN20	CAN2.0 Switch	3 x 1 header, pitch 2.00mm
E_JIAP1	For user update FW	3 x 1 header, pitch 2.00mm

ARC-1209/1509

E_JBOOT0	For user update FW	3 x 1 header, pitch 2.00mm
-----------------	--------------------	----------------------------

Connectors

Label	Function	Note
E_GPIO1	General purpose I/O connector	14 x 1 terminal, pitch 2.50mm
E_CN1	For user update FW	5 x 1 header, pitch 2.54mm
E_CAN1	CAN Bus connector	3 x 1 terminal, pitch 2.50mm
E_JB2B1	B2B connector	

2.8.6 ARC-BYT DB-F

Connectors

Label	Function	Note
F_CAN1	CAN Bus connector 1	7 x 2 header, pitch 2.00mm
F_CAN2	CAN Bus connector 2	
F_JB2B1	B2B connector	

2.8.7 ARC-BYT DB-G

Connectors

Label	Function	Note
G_COM1/2/3	Serial Port 1/2/3 connector	DB-9 male connector
G_JB2B1	B2B connector	

2.8.8 ARC-BYT DB-H

Jumpers

Label	Function	Note
H_USB_PWR_SEL1	USB Power selector	3 x 1 header, pitch 2.00mm

Connectors

Label	Function	Note
H_JUSB1	USB3.0 connector	
H_COM1/2	Serial Port 1/2 connector	DB-9 male connector
H_JB2B1	B2B connector	

2.8.9 ARC-BYT DB-K

Connectors

Label	Function	Note
-------	----------	------

I_JLAN1	RJ-45 Ethernet	
I_COM1/2	Serial Port 1/2 connector	DB-9 male connector
I_JB2B1	B2B connector	

2.9 ARC-BYT DB-D Connectors settings

2.9.1 Serial Port 1 connector (D_COM1)

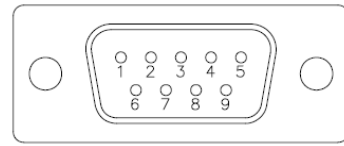
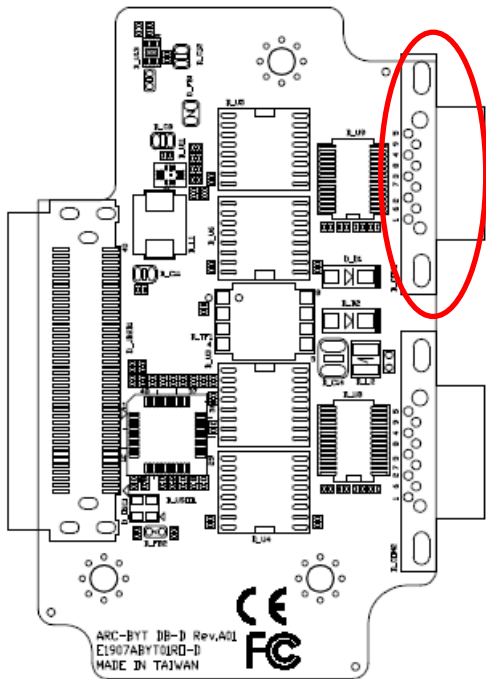

Signal	PIN	PIN	Signal
NDCD#_3_D	1	6	NDSR#_3_D
NRXD_3_D	2	7	NRTS#_3_D
NTXD_3_D	3	8	NCTS#_3_D
NDTR#_3_D	4	9	NRI#_3_D
GND	5		

2.9.2 Serial Port 2 connector (D_COM2)

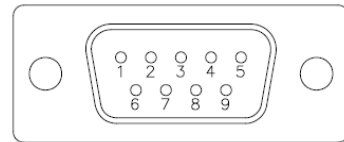
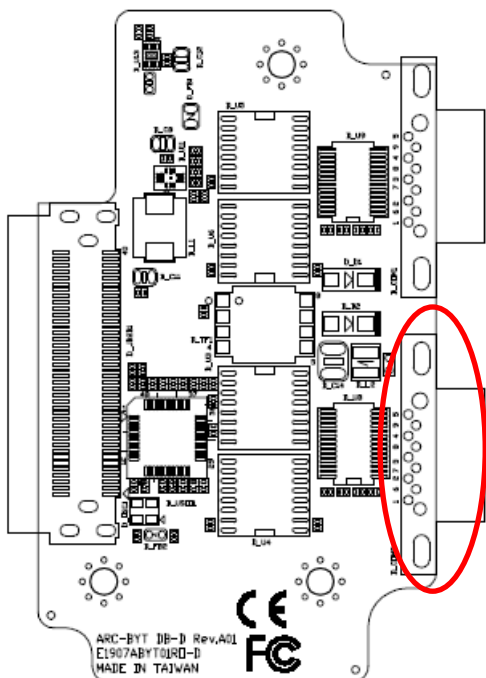

Signal	PIN	PIN	Signal
NDCD#_2_D	1	6	NDSR#_2_D
NRXD_2_D	2	7	NRTS#_2_D
NTXD_2_D	3	8	NCTS#_2_D
NDTR#_2_D	4	9	NRI#_2_D
GND	5		

2.10 ARC-BYT DB-E Jumpers & Connectors settings

2.10.1 CAN2.0 Switch (E_JCAN20)

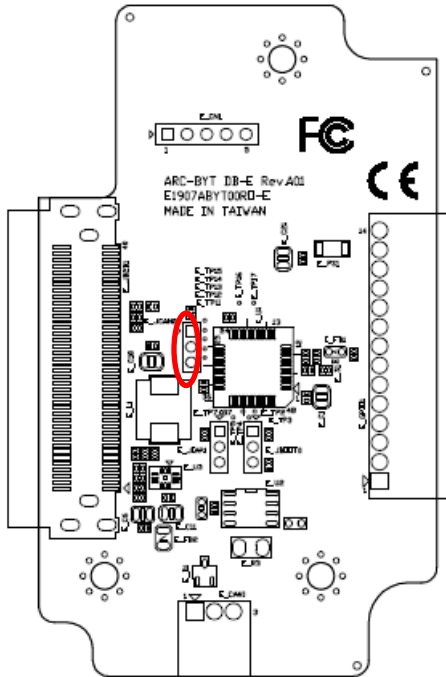

CAN2.0A (11-bit)*

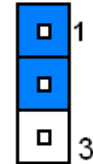

CAN2.0B (29-bit)

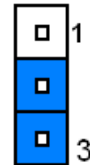

*Default

2.10.2 For user update FW (E_JBOOT0)

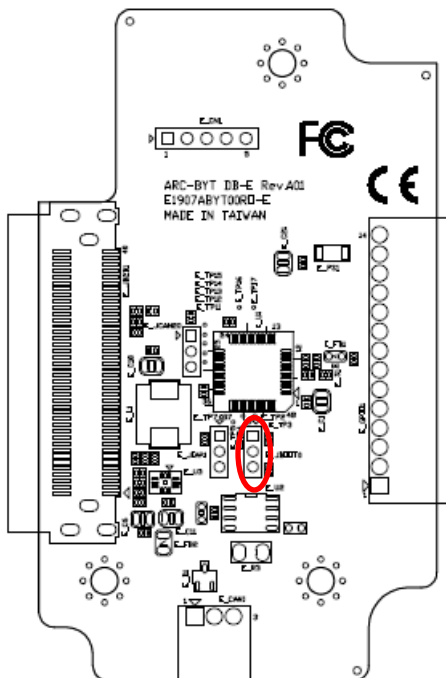

Default*

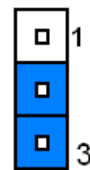

For user update FW

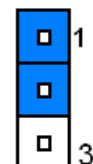

*Default

2.10.3 For user update FW (E_JIAP1)

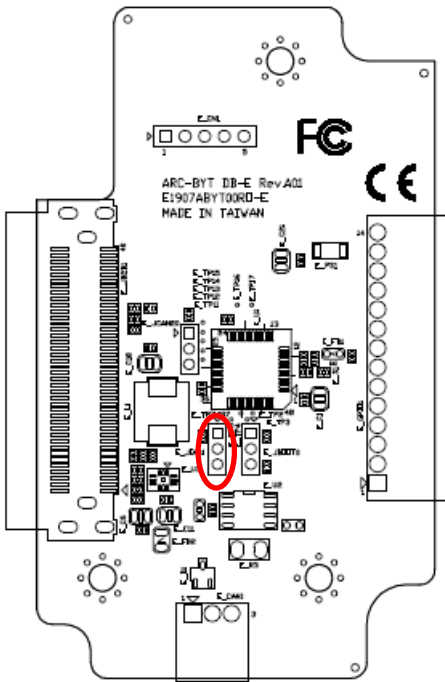

Default*

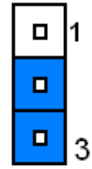

For user update FW

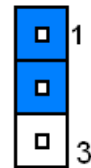

*Default

2.10.4 For user update FW (E_CN1)

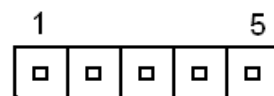
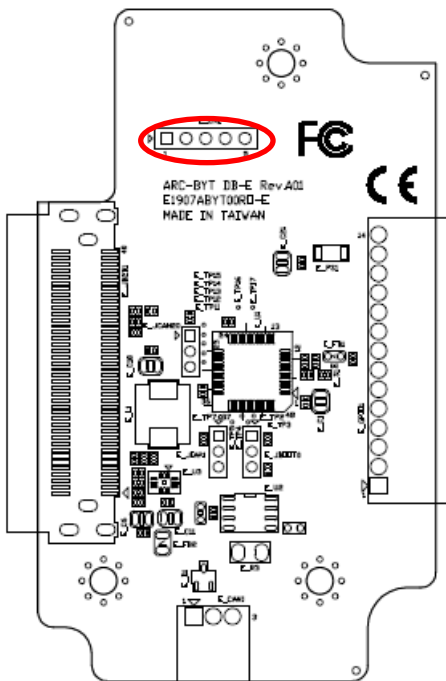

Signal	PIN
+3.3V	1
SWDIO	2
SWCLK	3
CAN_BUS_RESET#	4
GND	5

2.10.5 General purpose I/O connector (E_GPIO1)

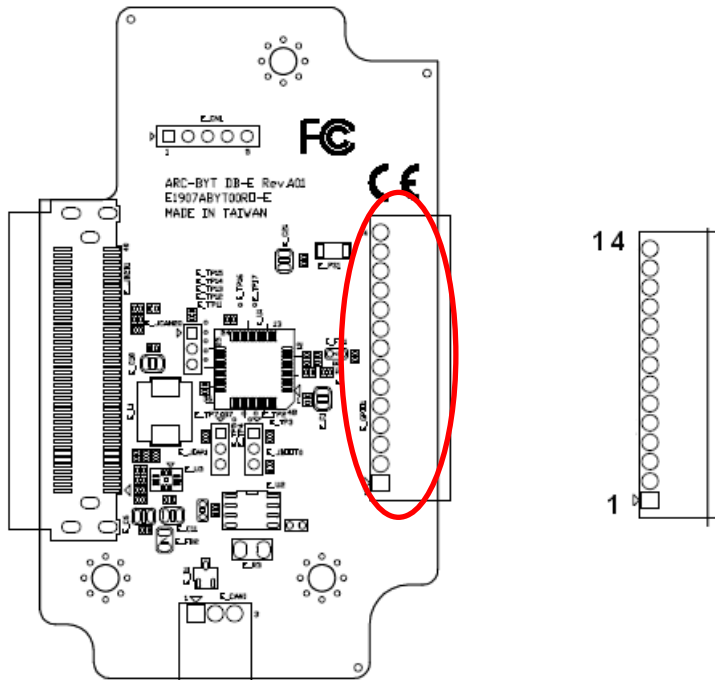

Signal	PIN
GND	14
+3.3V	13
DO5	12
DO4	11
DO3	10
DO2	9
DO1	8
DO0	7
DI5	6
DI4	5
DI3	4
DI2	3
DI1	2
DI0	1

2.10.6 CAN Bus connector (E_CAN1)

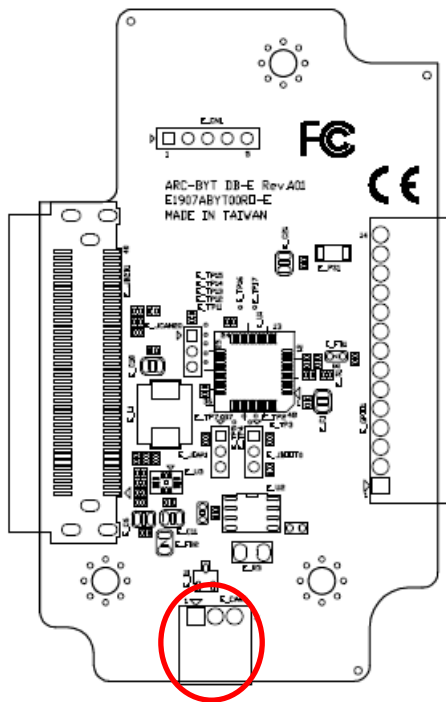

Signal	PIN
CANH	1
CANL	2
GND	3

2.11 ARC-BYT DB-F Connectors settings

2.11.1 CAN Bus connector 1 (F_CAN1)

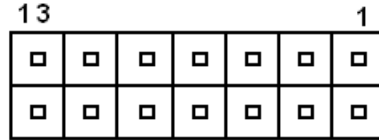
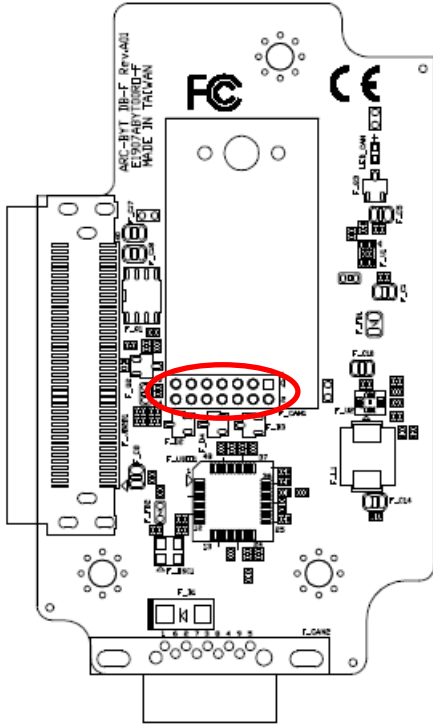

Signal	PIN	PIN	Signal
CAN_PWR	1	2	CAN_8
CAN_IND	3	4	CAN_9
GND	5	6	BAT_GND
CAN_WAKE	7	8	CAN_11
UART_RXD_1_F	9	10	CAN_12
UART_TXD_1_F	11	12	CAN_13
+5V	13	14	CAN_14

2.11.2 CAN Bus connector 2 (F_CAN2)

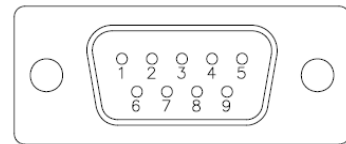
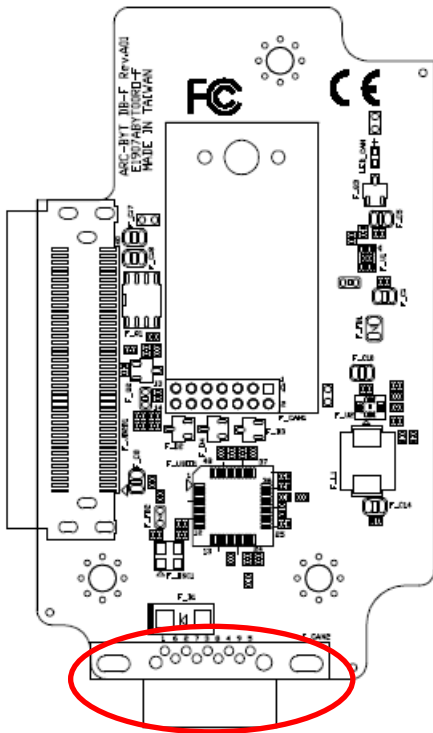

Signal	PIN	PIN	Signal
BAT_PWR	1	6	CAN_12
CAN_8	2	7	CAN_13
CAN_9	3	8	CAN_14
BAT_GND	4	9	NC
CAN_11	5		

2.12 ARC-BYT DB-H Jumpers settings

2.12.1 USB Power selector (H_USB_PWR_SEL1)

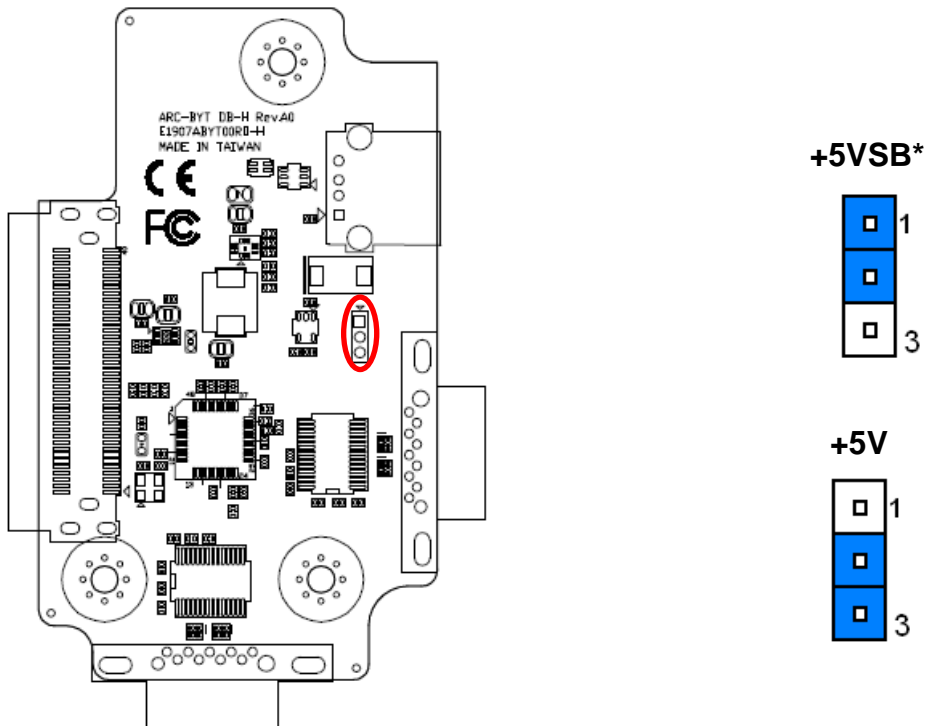

*Default

2.13 ARC-BYT DB-G Connectors settings

2.13.1 Serial Port 1 connector (G_COM1)

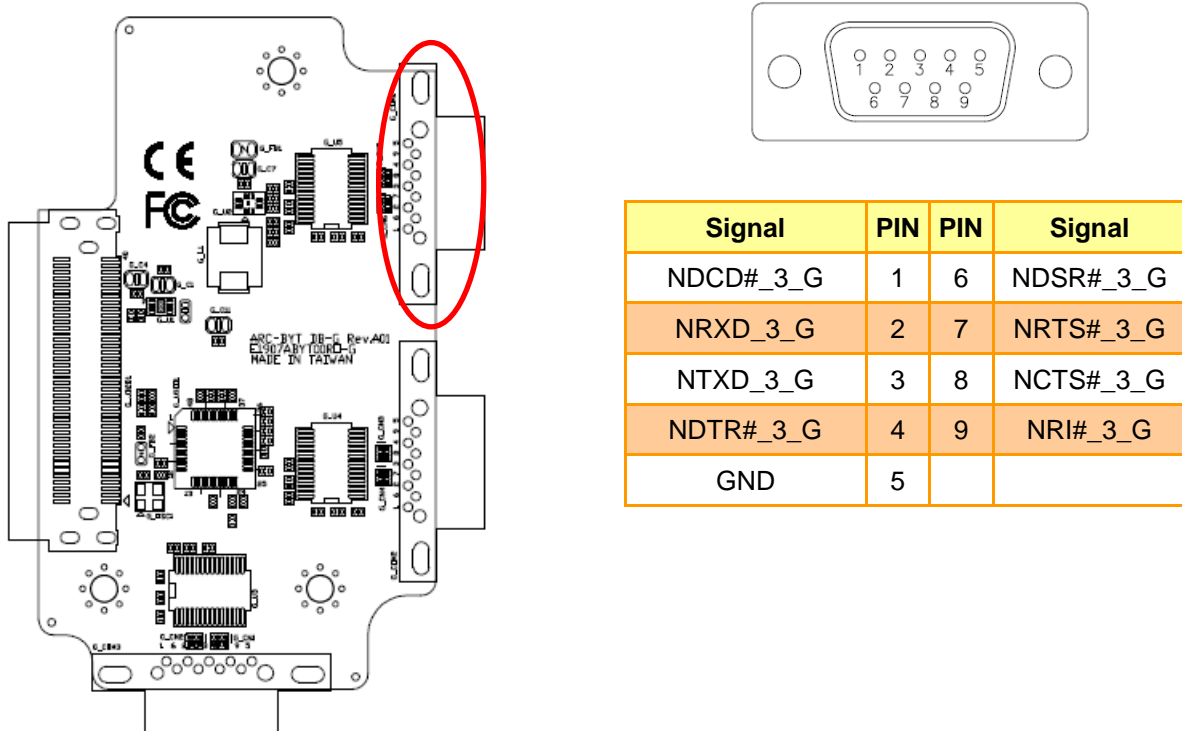

2.13.2 Serial Port 2 connector (G_COM2)

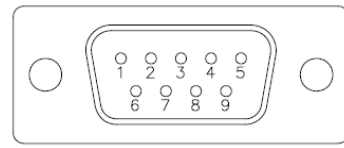
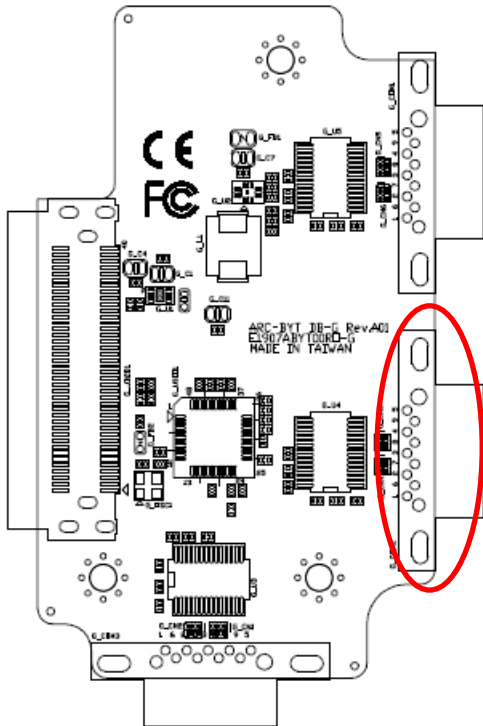

Signal	PIN	PIN	Signal
NDCD#_2_G	1	6	NDSR#_2_G
NRXD_2_G	2	7	NRTS#_2_G
NTXD_2_G	3	8	NCTS#_2_G
NDTR#_2_G	4	9	NRI#_2_G
GND	5		

2.13.3 Serial Port 3 connector (G_COM3)

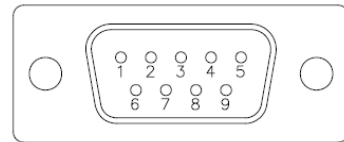
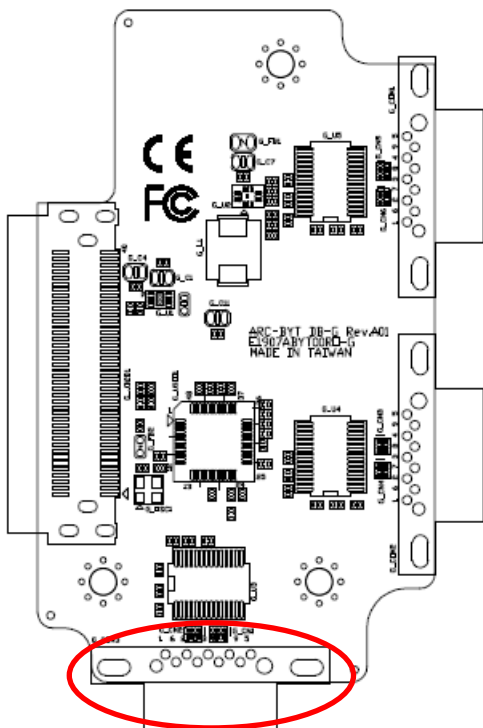

Signal	PIN	PIN	Signal
NDCD#_1_G	1	6	NDSR#_1_G
NRXD_1_G	2	7	NRTS#_1_G
NTXD_1_G	3	8	NCTS#_1_G
NDTR#_1_G	4	9	NRI#_1_G
GND	5		

2.14 ARC-BYT DB-H Connectors settings

2.14.1 Serial Port 1 connector (H_COM1)

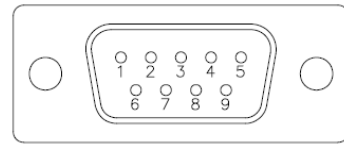
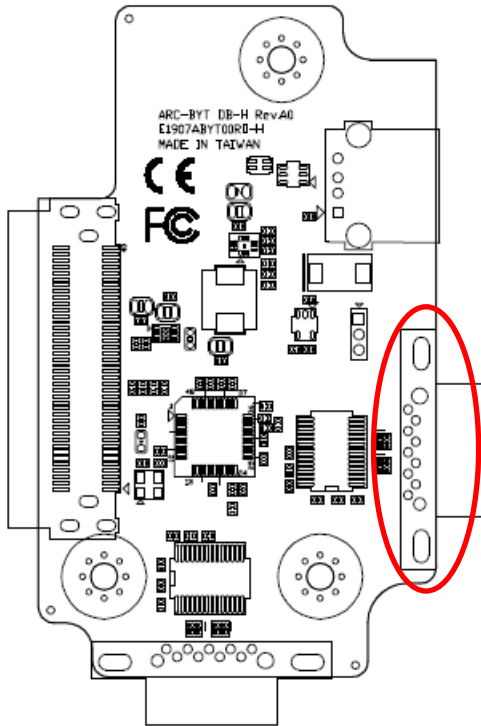

Signal	PIN	PIN	Signal
NDCD#_1_H	1	6	NDSR#_1_H
NRXD_1_H	2	7	NRTS#_1_H
NTXD_1_H	3	8	NCTS#_1_H
NDTR#_1_H	4	9	NRI#_1_H
GND	5		

2.14.2 Serial Port 2 connector (H_COM2)

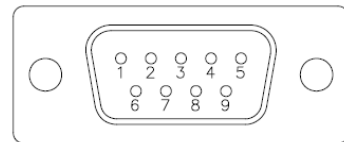
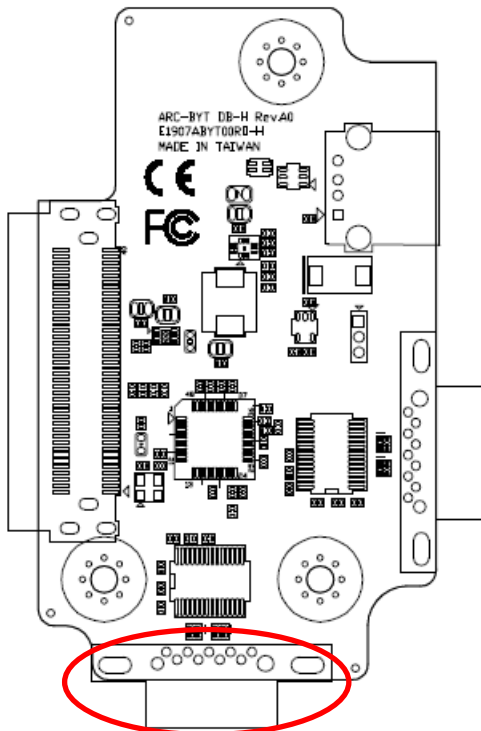

Signal	PIN	PIN	Signal
NDCD#_2_H	1	6	NDSR#_2_H
NRXD_2_H	2	7	NRTS#_2_H
NTXD_2_H	3	8	NCTS#_2_H
NDTR#_2_H	4	9	NRI#_2_H
GND	5		

2.15 ARC-BYT DB-K Connectors settings

2.15.1 Serial Port 1 connector (I_COM1)

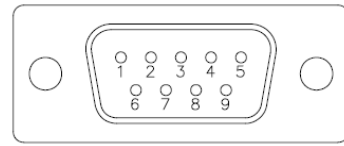
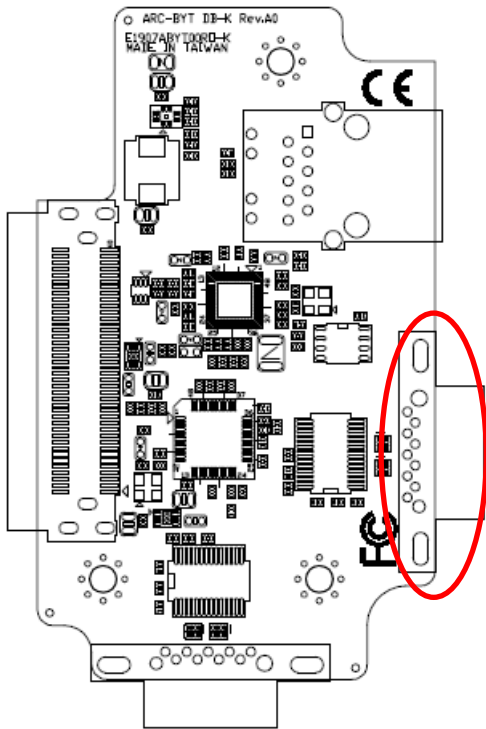

Signal	PIN	PIN	Signal
NDCD#_1_I	1	6	NDSR#_1_I
NRXD_1_I	2	7	NRTS#_1_I
NTXD_1_I	3	8	NCTS#_1_I
NDTR#_1_I	4	9	NRI#_1_I
GND	5		

2.15.2 Serial Port 2 connector (I_COM2)

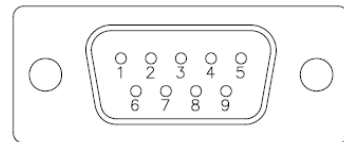
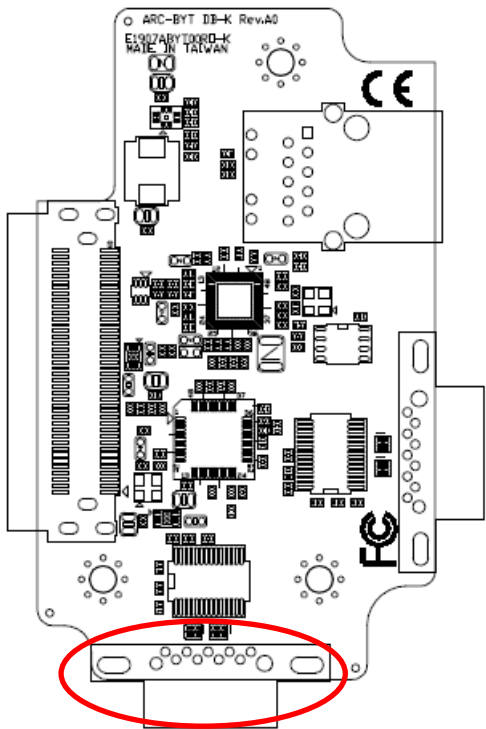

Signal	PIN	PIN	Signal
NDCD#_2_I	1	6	NDSR#_2_I
NRXD_2_I	2	7	NRTS#_2_I
NTXD_2_I	3	8	NCTS#_2_I
NDTR#_2_I	4	9	NRI#_2_I
GND	5		

3. BIOS Setup

3.1 Introduction

The BIOS setup program allows users to modify the basic system configuration. In this following chapter will describe how to access the BIOS setup program and the configuration options that may be changed.

3.2 Starting Setup

The AMI BIOS™ is immediately activated when you first power on the computer. The BIOS reads the system information contained in the NVRAM and begins the process of checking out the system and configuring it. When it finishes, the BIOS will seek an operating system on one of the disks and then launch and turn control over to the operating system.

While the BIOS is in control, the Setup program can be activated in one of two ways:

By pressing or <F2> immediately after switching the system on, or

By pressing the or <F2> key when the following message appears briefly at the left-top of the screen during the POST (Power On Self Test).

Press or <F2> to enter SETUP

If the message disappears before you respond and you still wish to enter Setup, restart the system to try again by turning it OFF then ON or pressing the "RESET" button on the system case. You may also restart by simultaneously pressing <Ctrl>, <Alt>, and <Delete> keys. If you do not press the keys at the correct time and the system does not boot, an error message will be displayed and you will again be asked to.

Press F1 to Continue, DEL to enter SETUP

3.3 Using Setup

In general, you use the arrow keys to highlight items, press <Enter> to select, use the PageUp and PageDown keys to change entries, press <F1> for help and press <Esc> to quit. The following table provides more detail about how to navigate in the Setup program using the keyboard.

Button	Description
↑	Move to previous item
↓	Move to next item
←	Move to the item in the left hand
→	Move to the item in the right hand
Esc key	Main Menu -- Quit and not save changes into NVRAM Status Page Setup Menu and Option Page Setup Menu -- Exit current page and return to Main Menu
+ key	Increase the numeric value or make changes
- key	Decrease the numeric value or make changes
F1 key	General help, only for Status Page Setup Menu and Option Page Setup Menu
F2 key	Previous Values.
F3 key	Optimized defaults
F4 key	Save & Exit Setup

- **Navigating Through The Menu Bar**

Use the left and right arrow keys to choose the menu you want to be in.



Note: Some of the navigation keys differ from one screen to another.

- **To Display a Sub Menu**

Use the arrow keys to move the cursor to the sub menu you want. Then press <Enter>. A “>” pointer marks all sub menus.

3.4 Getting Help

Press F1 to pop up a small help window that describes the appropriate keys to use and the possible selections for the highlighted item. To exit the Help Window press <Esc> or the F1 key again.

3.5 In Case of Problems

If, after making and saving system changes with Setup, you discover that your computer no longer is able to boot, the AMI BIOS supports an override to the NVRAM settings which resets your system to its defaults.

The best advice is to only alter settings which you thoroughly understand. To this end, we strongly recommend that you avoid making any changes to the chipset defaults. These defaults have been carefully chosen by both BIOS Vendor and your systems manufacturer to provide the absolute maximum performance and reliability. Even a seemingly small change to the chipset setup has the potential for causing you to use the override.

3.6 BIOS setup

Once you enter the Aptio Setup Utility, the Main Menu will appear on the screen. The Main Menu allows you to select from several setup functions and exit choices. Use the arrow keys to select among the items and press <Enter> to accept and enter the sub-menu.

3.6.1 Advanced Menu

This section allows you to configure your CPU and other system devices for basic operation through the following sub-menus.

3.6.1.1 IT8528 Super IO Configuration

When new DB board is connected, item value should be adjusted manually.

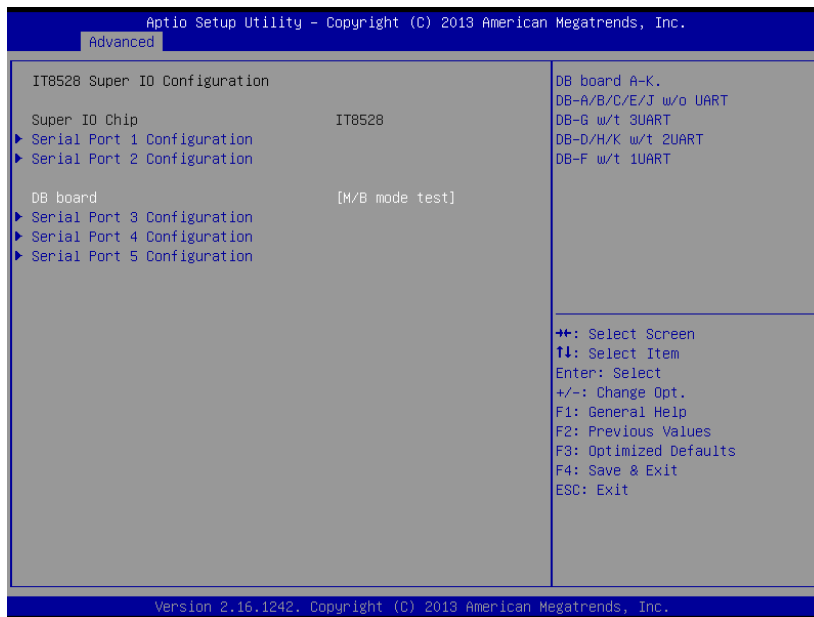

Item	Option	Description
DB board	DB-A/C/E/J DB-B DB-F 1COM DB-D/H/K 2COM DB-G 3COM M/B mode test[Default]	DB board A-K. DB-A/B/C/D/E/J w/o UART DB-G w/t 3UART DB-D/H/K w/t 2UART DB-F w/t 1UART.

