

M.2 (P110)

4IG2-P Series

Customer: _____
Customer
Part
Number: _____
Innodisk
Part
Number: _____
Innodisk
Model Name: _____
Date: _____

Innodisk Approver	Customer Approver

**Total Solution For
Industrial Flash Storage**

Table of contents

1. PRODUCT OVERVIEW	8
1.1 INTRODUCTION OF INNODISK M.2 (P110) 4IG2-P	8
1.2 PRODUCT VIEW AND MODELS	8
PCIe INTERFACE	9
2.1 CAPACITY AND DEVICE PARAMETERS	9
2.2 PERFORMANCE	9
2.3 ELECTRICAL SPECIFICATIONS	10
2.3.1 Power Requirement	<i>10</i>
2.3.2 Power Consumption	<i>10</i>
2.4 ENVIRONMENTAL SPECIFICATIONS	10
2.4.1 Temperature Ranges	<i>10</i>
2.4.2 Humidity	<i>10</i>
2.4.3 Shock and Vibration	<i>10</i>
2.4.4 Mean Time between Failures (MTBF)	<i>11</i>
2.5 CE AND FCC COMPATIBILITY	11
2.6 RoHS COMPLIANCE	11
2.7 RELIABILITY	11
2.8 TRANSFER MODE	12
2.10 MECHANICAL DIMENSIONS	14
2.11 ASSEMBLY WEIGHT	15
2.12 SEEK TIME	15
2.13 NAND FLASH MEMORY	15
3. THEORY OF OPERATION	16
3.1 OVERVIEW	16
3.2 PCIe GEN. 4 X4 CONTROLLER	16
3.3 ERROR DETECTION AND CORRECTION	17
3.4 WEAR-LEVELING	17
3.5 BAD BLOCKS MANAGEMENT	17
3.6 iDATA GUARD	17
3.7 GARBAGE COLLECTION/TRIM	17
3.8 THERMAL MANAGEMENT	18
3.9 iPOWER GUARD	18
3.10 DIE RAID	18
4. INSTALLATION REQUIREMENTS	19
4.1 M.2 (P110) 4IG2-P PIN DIRECTIONS	19
4.2 ELECTRICAL CONNECTIONS FOR M.2 (P110) 4IG2-P	19

4.3 DEVICE DRIVE	19
5. SMART / HEALTH INFORMATION.....	20
5.1 GET LOG PAGE (LOG IDENTIFIER 02H)	20
6. PART NUMBER RULE	24

Features:

- PCIe Gen. 4x4, NVMe SSD
- Innodisk 3D TLC NAND
- Support iSLC technology
- M.2 22110
- iDataguard
- Thermal throttling Management
- Support End-to-End Data Path Protection (ETEP)
- Support iCell technology

Performance:

- Sequential Read up to 7,050 MB/s
- Sequential Write up to 5,250 MB/s

Power Requirements:

Input Voltage:	3.3V±5%
Max Operating Wattage:	10.2W
Idle Wattage:	2.4W

Reliability:

Capacity	TBW	DWPD
160GB	6537	24.6
320GB	13134	24.7
640GB	27707	26.0
1.28TB	66780	31.4

Data Retention	10 Years
Warranty	5 Years

For warranty details, please refer to:

https://www.innodisk.com/en/support_and_service/warranty

REVISION HISTORY

Revision	Description	Date
V1.0	First release	May., 2023

List of Tables

TABLE 1: DEVICE PARAMETERS	9
TABLE 2: PERFORMANCE - 112 LAYERS 3D TLC	9
TABLE 3: INNODISK M.2 (P110) 4IG2-P POWER REQUIREMENT	10
TABLE 4: TYPICAL POWER CONSUMPTION	10
TABLE 5: TEMPERATURE RANGE FOR M.2 (P110) 4IG2-P	10
TABLE 6: SHOCK/VIBRATION TESTING FOR M.2 (P110) 4IG2-P	10
TABLE 7: M.2 (P110) 4IG2-P MTBF	11
TABLE 8: M.2 (P110) 4IG2-P TBW	11
TABLE 9: INNODISK M.2 (P110) 4IG2-P PIN ASSIGNMENT	13
TABLE 10: INNODISK M.2 (P110) 4IG2-P LED INDICATOR	13
TABLE 11: GET LOG PAGE – SMART / HEALTH INFORMATION LOG	20

List of Figures

FIGURE 1: INNODISK M.2 (P110) 4IG2-P	8
FIGURE 2: INNODISK M.2 (P110) 4IG2-P (STANDARD TEMPERATURE)	8
FIGURE 3: INNODISK M.2 (P110) 4IG2-P (WIDE TEMPERATURE)	8
FIGURE 4: INNODISK M.2 (P110) 4IG2-P WITH HEAT-SPREADING COPPER LAYER DIAGRAM	14
FIGURE 5: INNODISK M.2 (P110) 4IG2-P WITH HEAT-SPREADING COPPER LAYER DIAGRAM	14
FIGURE 6: INNODISK M.2 (P110) 4IG2-P	15
FIGURE 7: INNODISK M.2 (P110) 4IG2-P BLOCK DIAGRAM	16
FIGURE 8: SIGNAL SEGMENT AND POWER SEGMENT	19

1. Product Overview

1.1 Introduction of Innodisk M.2 (P110) 4IG2-P

Innodisk M.2 (P110) 4IG2-P is iSLC series which is designed to outdo the endurance, performance and reliability of 3D TLC-based solutions. Through the use of flash management algorithms, iSLC improves SSD endurance up to 100,000 times. In addition, iSLC improves the performance of solid state drives, with similar write performance of SLC-based solutions.

M.2 (P110) 4IG2-P supports PCIe Gen. 4x4, and it is compliant with NVMe 1.4 providing excellent performance. M.2 (P110) 4IG2-P with heat-spreading design dissipate heat generating from IC making SSD perform more steady. M.2 (P110) 4IG2-P have Die RAID protection to reduce bad blocks happening and optimize data integrity.

Innodisk M.2 (P110) 4IG2-P provides ultra-speed and high IOPS and offers maximum capacity up to 1.28TB, making the SSD optimal for server and heavy data workload applications.

CAUTION TRIM must be enabled.

TRIM enables SSD's controller to skip invalid data instead of moving. It can free up significant amount of resources, extends the lifespan of SSD by reducing erase, and write cycles on the SSD. Innodisk's handling of garbage collection along with TRIM command improves write performance on SSDs.

1.2 Product View and Models

Innodisk M.2 (P110) 4IG2-P is available in follow capacities within 3D TLC flash ICs.

M.2 (P110) 4IG2-P 160GB M.2 (P110) 4IG2-P 640GB

M.2 (P110) 4IG2-P 320GB M.2 (P110) 4IG2-P 1.28TB



Figure 1: Innodisk M.2 (P110) 4IG2-P

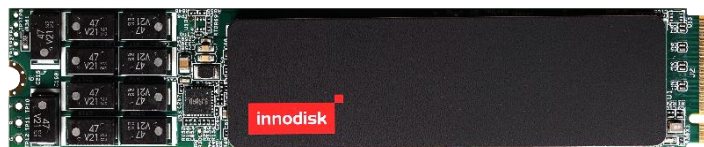

Figure 2: Innodisk M.2 (P110) 4IG2-P (Standard Temperature)



Figure 3: Innodisk M.2 (P110) 4IG2-P (Wide Temperature)

PCIe Interface

Innodisk M.2 (P110) 4IG2-P supports PCIe Gen. 4 interface and compliant with NVMe 1.4. M.2 (P110) 4IG2-P can work under PCIe Gen. 1, Gen. 2, Gen. 3 and Gen. 4.

Most of operating system includes NVMe in-box driver now. For more information about the driver support in each OS, please visit <http://nvmeexpress.org/resources/drivers>.

2. Product Specifications

2.1 Capacity and Device Parameters

M.2 (P110) 4IG2-P device parameters are shown in Table 1.

Table 1: Device parameters

Capacity	LBA	User Capacity(MB)
160GB	312581808	152627
320GB	625142448	305245
640GB	1250263728	610480
1.28TB	2500506288	1220950

2.2 Performance

Burst Transfer Rate: 8 GB/s

Table 2: Performance - 112 Layers 3D TLC

Capacity	Unit	ST				WT			
		160GB	320GB	640GB	1.28TB	160GB	320GB	640GB	1.28TB
Sequential** Read (Q8T1)	MB/s	4,800	7,050	6,700	6,550	4,800	7,050	6,650	6,350
Sequential** Write (Q8T1)		2,020	3,610	3,320	5,250	2,050	3,550	3,300	5,200
4KB Random** Read (Q32T16)	IOPS	376,000	685,000	647,000	1,298,000	373,000	685,000	645,000	778,000
4KB Random** Write (Q32T16)		519,000	854,000	848,000	886,000	534,000	863,000	852,000	774,000

Note: Performance may be different because ST and WT adopt different thermal solutions.

Performance is affected by thermal throttling if device temperatures is over 75C.

* Performance results are measured in Room Temperature with Out-of-Box devices and may vary depending on overall system setup.

** Performance results are based on CrystalDiskMark 7.0.0 with file size 1000MB. Unit of 4KB items is I.O.P.S.

2.3 Electrical Specifications

2.3.1 Power Requirement

Table 3: Innodisk M.2 (P110) 4IG2-P Power Requirement

Item	Symbol	Rating	Unit
Input voltage	V _{IN}	+3.3 DC +- 5%	V

2.3.2 Power Consumption

Table 4: Typical Power Consumption

Mode	Power Consumption (W)
Read	8.7
Write	10.4
Idle	2.4
Power-on peak	8.3

Target: 1.28TB M.2 (P110) 4IG2-P

Note: Current results may vary depending on system components and power circuit design

Please refer to the test report for other capacities

2.4 Environmental Specifications

2.4.1 Temperature Ranges

Table 5: Temperature range for M.2 (P110) 4IG2-P

Temperature	Range
Operating	Standard Grade: 0°C to +70°C Wide Grade: -40°C to +85°C
Storage	-40°C to +85°C SOP

2.4.2 Humidity

Relative Humidity: 10-95%, non-condensing

2.4.3 Shock and Vibration

Table 6: Shock/Vibration Testing for M.2 (P110) 4IG2-P

Reliability	Test Conditions	Reference Standards
Vibration	7 Hz to 2K Hz, 20G, 3 axes	IEC 60068-2-6
Mechanical Shock	Duration: 0.5ms, 1500 G, 3 axes	IEC 60068-2-27

2.4.4 Mean Time between Failures (MTBF)

Table 7 summarizes the MTBF prediction results for various M.2 (P110) 4IG2-P configurations. The analysis was performed using a RAM Commander™ failure rate prediction.

- **Failure Rate:** The total number of failures within an item population, divided by the total number of life units expended by that population, during a particular measurement interval under stated condition.
- **Mean Time between Failures (MTBF):** A basic measure of reliability for repairable items: The mean number of life units during which all parts of the item perform within their specified limits, during a particular measurement interval under stated conditions.

Table 7: M.2 (P110) 4IG2-P MTBF

Product	Condition	MTBF (Hours)
Innodisk M.2 (P110) 4IG2-P	Telcordia SR-332 GB, 25°C	>3,000,000

2.5 CE and FCC Compatibility

M.2 (P110) 4IG2-P conforms to CE and FCC requirements.

2.6 RoHS Compliance

M.2 (P110) 4IG2-P is fully compliant with RoHS directive.

2.7 Reliability

Table 8: M.2 (P110) 4IG2-P TBW

Parameter	Value	
Flash endurance	100,000 P/E cycles	
Error Correct Code	Support(LDPC)	
Data Retention	Under 40°C: 10 Years at initial NAND Status ; 1 Year at NAND Life End	
TBW* (Total Bytes Written) Unit: TB		
Capacity	Sequential workload	Client workload
160GB	14204	6537
320GB	28409	13134
640GB	56818	27707
1.28TB	116363	66780
* Note: 1. Sequential: Mainly sequential write are estimated by PassMark Burnin Test v8.1 pro. 2. Client: Follow JESD218 Test method and JESD219A Workload, tested by ULINK. (The capacity lower than 64GB client workload is not specified in JEDEC219A, the values are estimated.) 3. Based on out-of-box performance.		

2.8 Transfer Mode

M.2 (P110) 4IG2-P support following transfer mode:

PCIe Gen. 4: 8GB/s

PCIe Gen. 3: 4GB/s

PCIe Gen. 2: 2GB/s

PCIe Gen. 1: 1GB/s

2.9 Pin Assignment

Innodisk M.2 (P110) 4IG2-P follows standard M.2 spec, socket 3, key M PCIe-based SSD pinout. See Table 9 for M.2 (P110) 4IG2-P pin assignment.

Table 9: Innodisk M.2 (P110) 4IG2-P Pin Assignment

Signal Name	Pin #	Pin #	Signal Name
		75	GND
3.3V	74	73	GND
3.3V	72	71	GND
3.3V	70	69	NC
NC	68	67	NC
Notch	66	65	Notch
Notch	64	63	Notch
Notch	62	61	Notch
Notch	60	59	Notch
NC	58		
NC	56	57	GND
NC	54	55	REFCLKp
CLKREQ# (I/O)(0/3.3V)	52	53	REFCLKn
PERST# (I)(0/3.3V)	50	51	GND
NC	48	49	PERp0
NC	46	47	PERn0
ALERT	44	45	GND
NC(reserved for SMB_DATA)(I/O)(0/1.8V)	42	43	PETp0
NC(reserved for SMB_CLK)	40	41	PETn0
GND	38	39	GND
NC	36	37	PERp1
NC	34	35	PERn1
GND	32	33	GND
NC	30	31	PETp1
NC	28	29	PETn1
NC	26	27	GND
NC	24	25	PERp2
NC	22	23	PERn2
NC	20	21	GND
3.3V	18	19	PETp2
3.3V	16	17	PETn2
3.3V	14	15	GND
3.3V	12	13	PERp3
LED#(O)(OD)	10	11	PERn3
NC	8	9	GND
NC	6	7	PETp3
3.3V	4	5	PETn3
3.3V	2	3	GND
		1	GND

Table 10: Innodisk M.2 (P110) 4IG2-P LED indicator

LED Color	Function
Green	Power on
	Access

2.10 Mechanical Dimensions

M.2 Type 22110 with heat-spreading copper layer (Default accessory for Standard-Temperature)

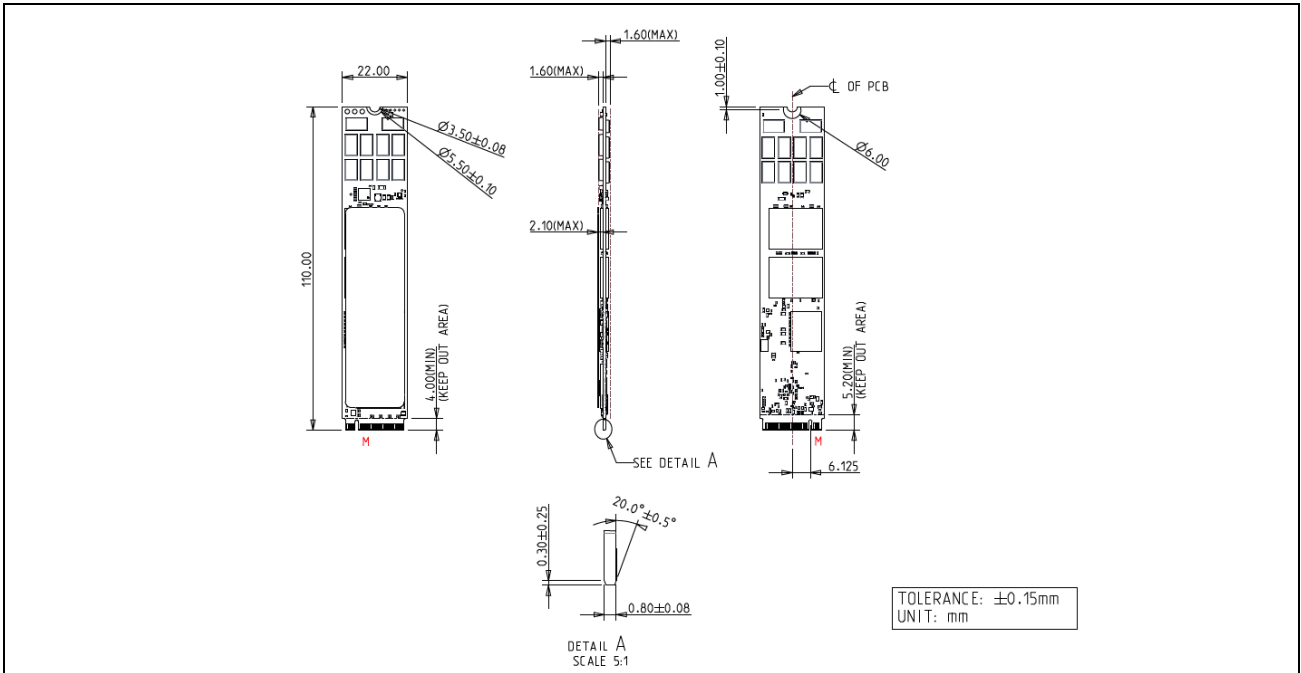

M.2 Type 22110 with heatsink (Default accessory for WT)

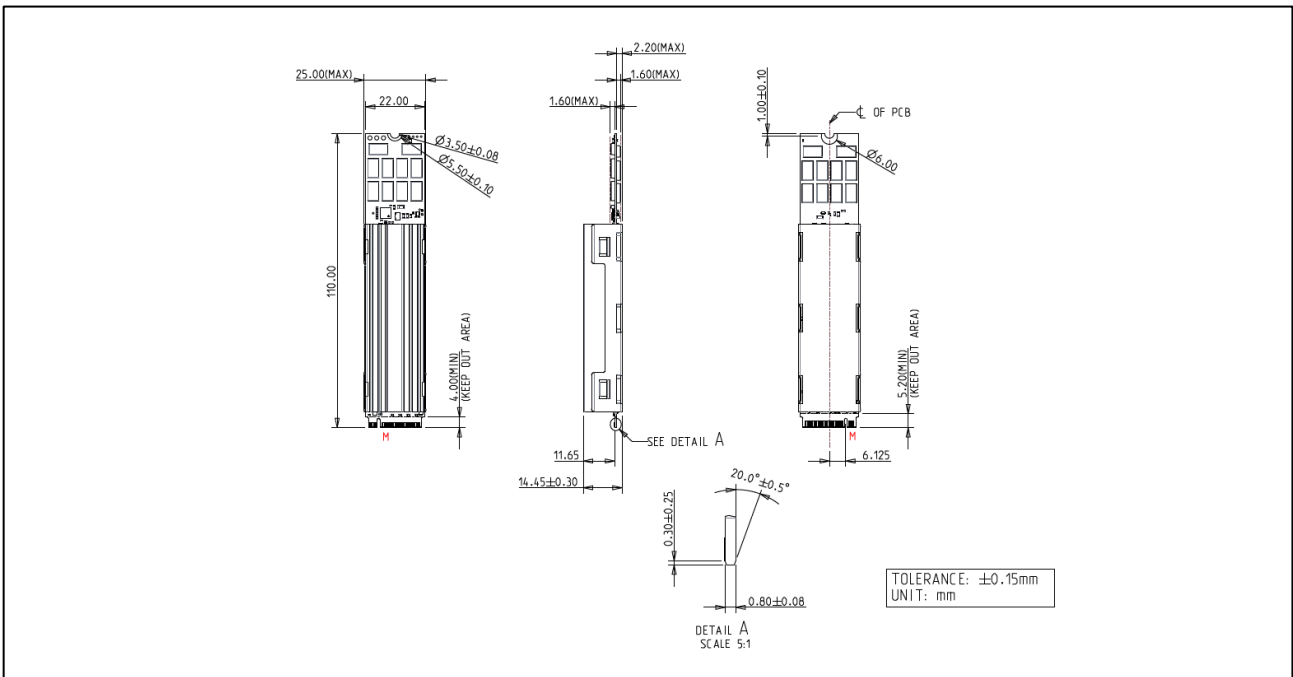

M.2 Type 22110

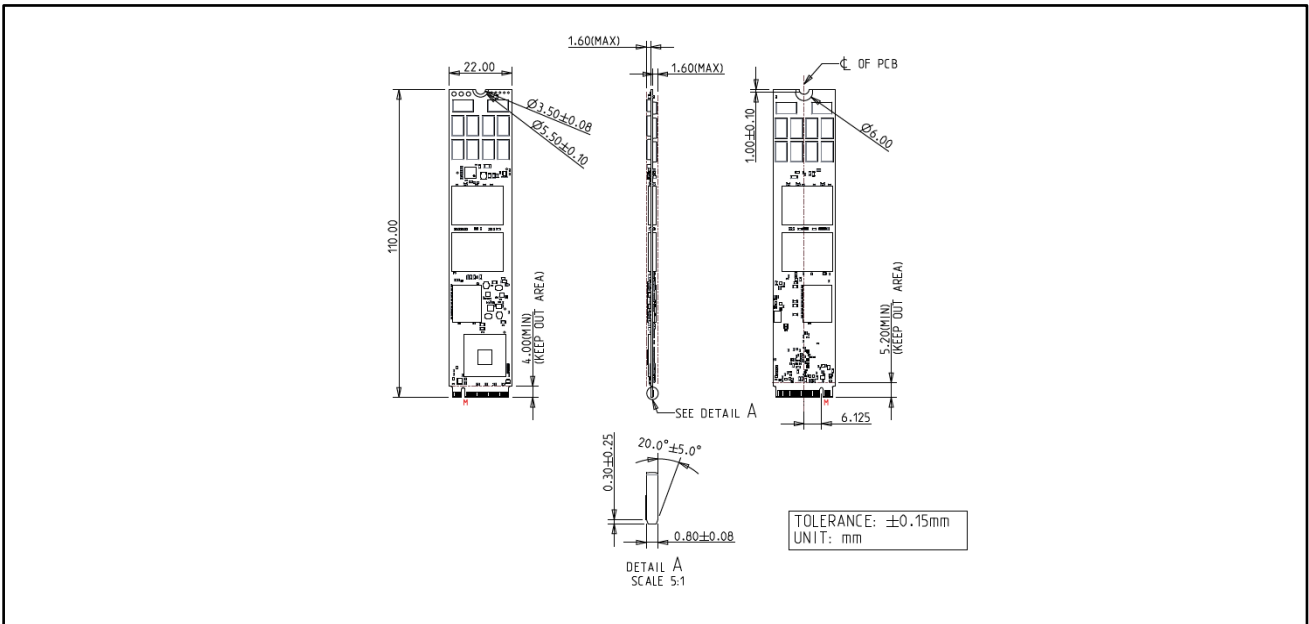

Figure 6: Innodisk M.2 (P110) 4IG2-P

2.11 Assembly Weight

An Innodisk M.2 (P110) 4IG2-P within NAND flash ICs, 160GB’s weight is 7 grams approximately.

2.12 Seek Time

Innodisk M.2 (P110) 4IG2-P is not a magnetic rotating design. There is no seek or rotational latency required.

2.13 NAND Flash Memory

Innodisk M.2 (P110) 4IG2-P uses 3D TLC NAND flash memory, which is non-volatility, high reliability and high speed memory storage.

3. Theory of Operation

3.1 Overview

Figure 7 shows the operation of Innodisk M.2 (P110) 4IG2-P from the system level, including the major hardware blocks.

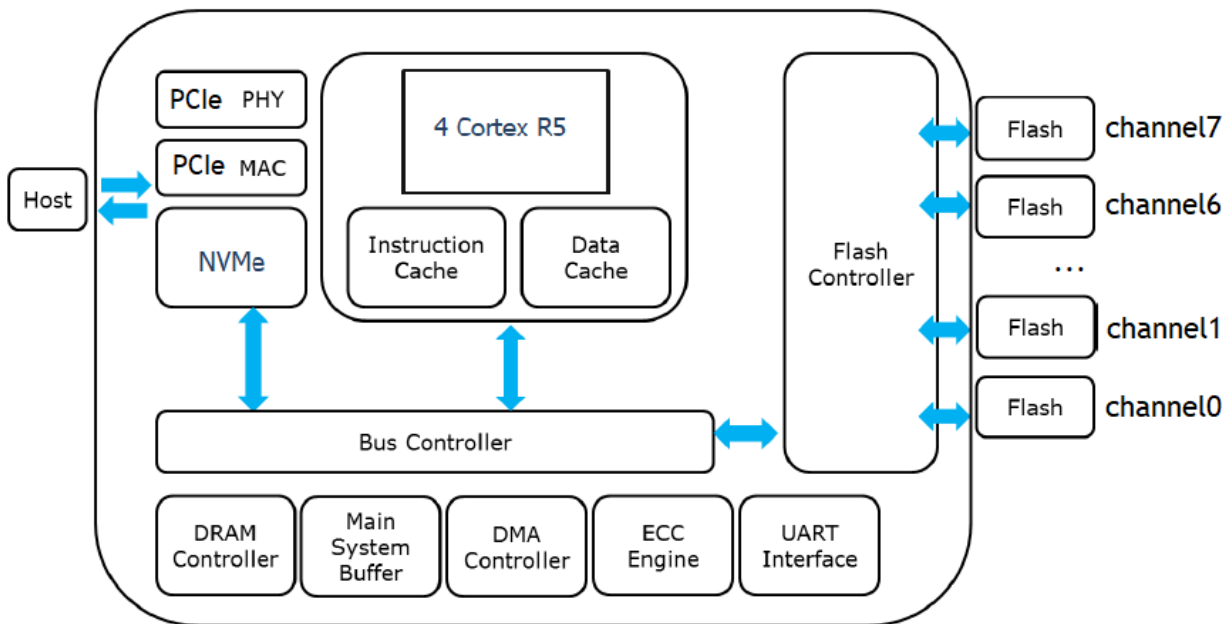

Figure 7: Innodisk M.2 (P110) 4IG2-P Block Diagram

Innodisk M.2 (P110) 4IG2-P integrates a PCIe Gen. 4x4 controller and NAND flash memories. Communication with the host occurs through the host interface, using the standard NVM protocol. Communication with the flash device(s) occurs through the flash interface.

3.2 PCIe Gen. 4 x4 Controller

Innodisk M.2 (P110) 4IG2-P is a PCIe Gen. 4x4 controller is compliant with NVMe 1.4, up to 32.0Gbps transfer speed. Also it is compliant with PCIe Gen. 1, Gen. 2, Gen. 3, and Gen. 4 specification. The controller supports up to 8 channels for flash interface.

3.3 Error Detection and Correction

Innodisk M.2 (P110) 4IG2-P is designed with hardware LDPC ECC engine with hard-decision and soft-decision decoding. Low-density parity-check (LDPC) codes have excellent error correcting performance close to the Shannon limit when decoded with the belief-propagation (BP) algorithm using soft-decision information.

3.4 Wear-Leveling

Flash memory can be erased within a limited number of times. This number is called the **erase cycle limit** or **write endurance limit** and is defined by the flash array vendor. The erase cycle limit applies to each individual erase block in the flash device.

Innodisk M.2 (P110) 4IG2-P uses a combination of two types of wear leveling- dynamic and static wear-leveling to distribute write cycling across an SSD and balance erase count of each block, thereby extending flash lifetime.

3.5 Bad Blocks Management

Bad Blocks are blocks that contain one or more invalid bits whose reliability are not guaranteed. The Bad Blocks may be presented while the SSD is shipped, or may develop during the life time of the SSD. When the Bad Blocks is detected, it will be flagged, and not be used anymore. The SSD implement Bad Blocks management, Bad Blocks replacement, Error Correct Code to avoid data error occurred. The functions will be enabled automatically to transfer data from Bad Blocks to spare blocks, and correct error bit.

3.6 iData Guard

Innodisk's iData Guard is a comprehensive data protection mechanism that functions before and after a sudden power outage to the SSD. Low-power detection terminates data writing before an abnormal power-off, while table-remapping after power-on deletes corrupt data and maintains data integrity. Innodisk's iData Guard provides effective power cycling management, preventing data stored in flash from degrading with use.

3.7 Garbage Collection/TRIM

Garbage collection and TRIM technology is used to maintain data consistency and perform continual data cleansing on SSDs. It runs as a background process, freeing up valuable controller resources while sorting good data into available blocks, and deleting bad blocks. It also significantly reduces write operations to the drive, thereby increasing the SSD's speed and lifespan.

3.8 Thermal Management

M.2 (P110) 4IG2-P has built-in thermal sensor which can detect environment temperature of SSD. In the meantime, firmware will monitor the thermal sensor to prevent any failure of overheating. During extreme temperature, firmware will adjust the data transfer behavior to maintain the SSD's reliable operation.

3.9 iPower Guard

iPower Guard technology is a set of preventive measures that protect the SSD in an unstable power supply environment. This comprehensive package comprises safeguards for startup and shutdown to maintain device performance and ensure data integrity.

3.10 Die RAID

Die RAID is a controller function which leveraged user capacity to back up the data in NAND flash. Die RAID supported can ensure the user data in the NAND Flash more consistent in certain scenario. Innodisk M.2 (P110) 4IG2-P series is default enable the Die RAID function for the industrial application.

4. Installation Requirements

4.1 M.2 (P110) 4IG2-P Pin Directions

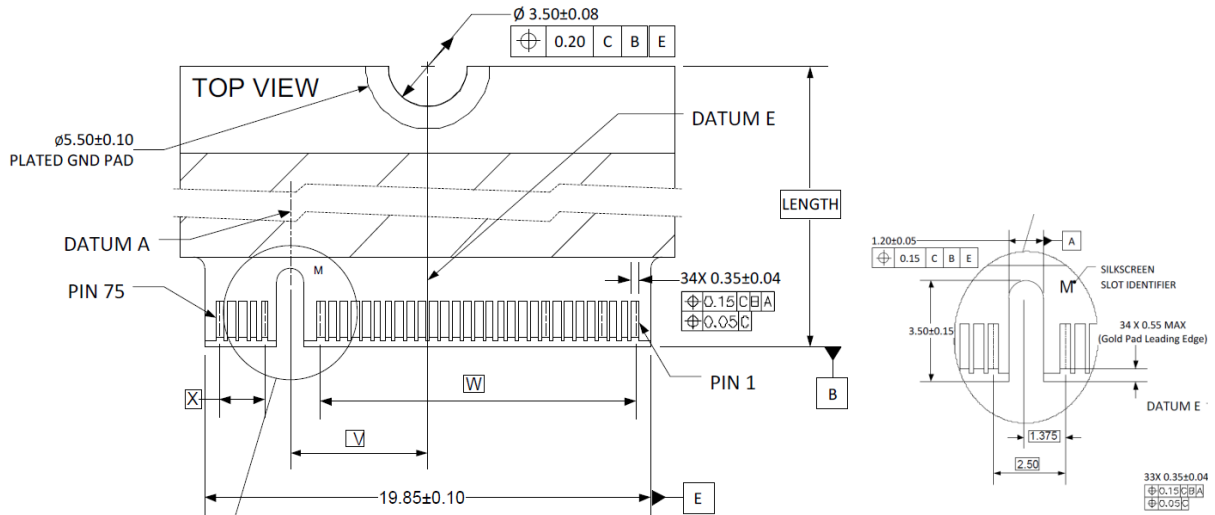

Figure 8: Signal Segment and Power Segment

4.2 Electrical Connections for M.2 (P110) 4IG2-P

M.2 interconnect is based on a 75 position Edge Card connector. The 75 position connector is intended to be keyed so as to distinguish between families of host interfaces and the various Sockets used in general Platforms. M.2 (P110) 4IG2-P is compliant with M.2 Socket 3 key M. M.2 (P110) 4IG2-P is compatible with host connector H4.2.

4.3 Device Drive

M.2 (P110) 4IG2-P is compliant with NVMe 1.4. Both Operation System and BIOS should include NVMe driver to compatible with NVMe device. Nowadays, most of OS includes NVMe in-box driver now. For more information about the driver support in each OS, please visit the website <http://nvmexpress.org/resources/drivers>. For BIOS NVMe driver support please contact with motherboard manufacture.

5. SMART / Health Information

This log page is used to provide SMART and general health information. The information provided is over the life of the controller and is retained across power cycles. More details about Set Features command; please refer to NVM Express 1.3

5.1 Get Log Page (Log Identifier 02h)

Innodisk 4IG2-P series SMART / Health Information Log are listed in following table.

Table 11: Get Log Page – SMART / Health Information Log

Bytes	Description														
0	<p>Critical Warning: This field indicates critical warnings for the state of the controller. Each bit corresponds to a critical warning type; multiple bits may be set. If a bit is cleared to '0', then that critical warning does not apply. Critical warnings may result in an asynchronous event notification to the host. Bits in this field represent the current associated state and are not persistent.</p> <table border="1"> <thead> <tr> <th>Bit</th> <th>Definition</th> </tr> </thead> <tbody> <tr> <td>00</td> <td>If set to '1', then the available spare space has fallen below the threshold.</td> </tr> <tr> <td>01</td> <td>If set to '1', then a temperature is above an over temperature threshold or below an under</td> </tr> <tr> <td>02</td> <td>If set to '1', then the NVM subsystem reliability has been degraded due to significant media related</td> </tr> <tr> <td>03</td> <td>If set to '1', then the media has been placed in read only mode.</td> </tr> <tr> <td>04</td> <td>If set to '1', then the volatile memory backup device has failed. This field is only valid if the</td> </tr> <tr> <td>07:05</td> <td>Reserved</td> </tr> </tbody> </table>	Bit	Definition	00	If set to '1', then the available spare space has fallen below the threshold.	01	If set to '1', then a temperature is above an over temperature threshold or below an under	02	If set to '1', then the NVM subsystem reliability has been degraded due to significant media related	03	If set to '1', then the media has been placed in read only mode.	04	If set to '1', then the volatile memory backup device has failed. This field is only valid if the	07:05	Reserved
Bit	Definition														
00	If set to '1', then the available spare space has fallen below the threshold.														
01	If set to '1', then a temperature is above an over temperature threshold or below an under														
02	If set to '1', then the NVM subsystem reliability has been degraded due to significant media related														
03	If set to '1', then the media has been placed in read only mode.														
04	If set to '1', then the volatile memory backup device has failed. This field is only valid if the														
07:05	Reserved														
2:1	<p>Composite Temperature: Contains a value corresponding to a temperature in degrees Kelvin that represents the current composite temperature of the controller and namespace(s) associated with that controller. The manner in which this value is computed is implementation specific and may not represent the actual temperature of any physical point in the NVM subsystem. The value of this field may be used to trigger an asynchronous event.</p> <p>Warning and critical overheating composite temperature threshold values are reported by the WCTEMP and CCTEMP fields in the Identify Controller data structure.</p>														
3	<p>Available Spare: Contains a normalized percentage (0 to 100%) of the remaining spare capacity available.</p>														

4	Available Spare Threshold: When the Available Spare falls below the threshold indicated in this field, an asynchronous event completion may occur. The value is indicated as a normalized percentage (0 to 100%).
5	Percentage Used: Contains a vendor specific estimate of the percentage of NVM subsystem life used based on the actual usage and the manufacturer's prediction of NVM life. A value of 100 indicates that the estimated endurance of the NVM in the NVM subsystem has been consumed, but may not indicate an NVM subsystem failure. The value is allowed to exceed 100. Percentages greater than 254 shall be represented as 255. This value shall be updated once per power-on hour (when the controller is not in a sleep state). Refer to the JEDEC JESD218A standard for SSD device life and endurance measurement techniques.
31:6	Reserved
47:32	Data Units Read: Contains the number of 512 byte data units the host has read from the controller; this value does not include metadata. This value is reported in thousands (i.e., a value of 1 corresponds to 1000 units of 512 bytes read) and is rounded up. When the LBA size is a value other than 512 bytes, the controller shall convert the amount of data read to 512 byte units. For the NVM command set, logical blocks read as part of Compare and Read operations shall be included in this value.
63:48	Data Units Written: Contains the number of 512 byte data units the host has written to the controller; this value does not include metadata. This value is reported in thousands (i.e., a value of 1 corresponds to 1000 units of 512 bytes written) and is rounded up. When the LBA size is a value other than 512 bytes, the controller shall convert the amount of data written to 512 byte units. For the NVM command set, logical blocks written as part of Write operations shall be included in this value. Write Uncorrectable commands shall not impact this value.
79:64	Host Read Commands: Contains the number of read commands completed by the controller. For the NVM command set, this is the number of Compare and Read commands.
95:80	Host Write Commands: Contains the number of write commands completed by the controller. For the NVM command set, this is the number of Write commands.
111:96	Controller Busy Time: Contains the amount of time the controller is busy with I/O commands. The controller is busy when there is a command outstanding to an I/O Queue (specifically, a command was issued via an I/O Submission Queue Tail doorbell write and the corresponding completion queue entry has not been posted yet to the associated I/O Completion Queue). This value is reported in minutes.
127:112	Power Cycles: Contains the number of power cycles.

143:128	Power On Hours: Contains the number of power-on hours. This may not include time that the controller was powered and in a non-operational power state.
159:144	Unsafe Shutdowns: Contains the number of unsafe shutdowns. This count is incremented when a shutdown notification (CC.SHN) is not received prior to loss of power.
175:160	Media and Data Integrity Errors: Contains the number of occurrences where the controller detected an unrecovered data integrity error. Errors such as uncorrectable ECC, CRC checksum failure, or LBA tag mismatch are included in this field.
191:176	Number of Error Information Log Entries: Contains the number of Error Information log entries over the life of the controller.
195:192	Warning Composite Temperature Time: Contains the amount of time in minutes that the controller is operational and the Composite Temperature is greater than or equal to the Warning Composite Temperature Threshold (WCTEMP) field and less than the Critical Composite Temperature Threshold (CCTEMP) field in the Identify Controller data structure. If the value of the WCTEMP or CCTEMP field is 0h, then this field is always cleared to 0h regardless of the Composite Temperature value.
199:196	Critical Composite Temperature Time: Contains the amount of time in minutes that the controller is operational and the Composite Temperature is greater than the Critical Composite Temperature Threshold (CCTEMP) field in the Identify Controller data structure. If the value of the CCTEMP field is 0h, then this field is always cleared to 0h regardless of the Composite Temperature value.
201:200	Temperature Sensor 1: Controller's Tj temperature
203:202	Temperature Sensor 2: Flash package's Tj temperature (Channel #0 CE #0). This Flash package is located the closet to the controller IC on M.2 family.
205:204	Temperature Sensor 3: Flash package's Tj temperature (Channel #0 CE #0). This Flash package is located the closet to the controller IC on M.2 family.
207:206	Temperature Sensor 4: Flash package's Tj temperature (Channel #7 CE #0).
209:208	Temperature Sensor 5: Flash Tj max temperature from Channel #0 to Channel #3 Flash packages.
211:210	Temperature Sensor 6: Flash Tj max temperature from Channel #4 to Channel #7 Flash packages.
213:212	Temperature Sensor 7: Flash Tj minimum temperature from Channel #0 to Channel #3 Flash packages.
215:214	Temperature Sensor 8: Flash Tj minimum temperature from Channel #4 to Channel #7 Flash packages.
219:216	Thermal Management Temperature 1 Transition Count: Contains the number of times the controller transitioned to lower power active power states or performed vendor

	specific thermal management actions while minimizing the impact on performance in order to attempt to reduce the Composite Temperature because of the host controlled thermal management feature (refer to section 8.4.5) (i.e., the Composite Temperature rose above the Thermal Management Temperature 1.) This counter shall not wrap once it reaches its maximum value. A value of zero, indicates that this transition has never occurred or this field is not implemented.
223:220	Thermal Management Temperature 2 Transition Count: Contains the number of times the controller transitioned to lower power active power states or performed vendor specific thermal management actions regardless of the impact on performance (e.g., heavy throttling) in order to attempt to reduce the Composite Temperature because of the host controlled thermal management feature (refer to section 8.4.5) (i.e., the Composite Temperature rose above the Thermal Management Temperature 2.) This counter shall not wrap once it reaches its maximum value. A value of zero, indicates that this transition has never occurred or this field is not implemented.
227:224	Total Time For Thermal Management Temperature 1: Contains the number of seconds that the controller had transitioned to lower power active power states or performed vendor specific thermal management actions while minimizing the impact on performance in order to attempt to reduce the Composite Temperature because of the host controlled thermal management feature (refer to section 8.4.5). This counter shall not wrap once it reaches its maximum value. A value of zero, indicates that this transition has never occurred or this field is not implemented.
231:228	Total Time For Thermal Management Temperature 2: Contains the number of seconds that the controller had transitioned to lower power active power states or performed vendor specific thermal management actions regardless of the impact on performance (e.g., heavy throttling) in order to attempt to reduce the Composite Temperature because of the host controlled thermal management feature (refer to section 8.4.5). This counter shall not wrap once it reaches its maximum value. A value of zero, indicates that this transition has never occurred or this field is not implemented.
511:232	Reserved

The innodisk M.2 (P110) series thermal sensor take ambient air temperature as a reference with any airflow condition, and the data can refer to iSMART.

Notes: More detailed health info has been defined by innodisk and will be shown on iSMART V5.3.21 (or later version).

6. Part Number Rule

CODE	1	2	3	4	5	6	7	8	9	10	11	12	13	14	15	16	17	18	19	20	21
	D	H	M	2	1	-	A	6	0	D	P	1	K	C	B	E	L	P	(H)	-	X
Definition																					
Code 1st (Disk)											Code 14th (Operation Temperature)										
D: Disk											C: Standard Grade (0°C~ +70°C)										
Code 2nd (Feature set)											Code 15th (Internal control)										
H: iSLC Series											W: Industrial Grade (-40°C~ +85°C)										
Code 3rd ~5th (Form factor)											Code 16th (Channel of data transfer)										
M21: M.2 Type 22110											A~Z: BGA PCB version.										
Code 7th ~9th (Capacity)											Code 17th (Flash Type)										
A60: 160GB			D2G: 320GB			F4G: 640GB					E: Eight channels										
1T2: 1.28TB																					
Code 10th ~12th (Controller)											Code 18th (Optional function)										
DP1: PCIe 4IG2-P series											L/Q: Innodisk 3D TLC NAND										
Code 13th (Flash mode)											Code 20th ~ (Customize code)										
K: 3D TLC 112 layers											P: iCell feature										
											PH: iCell feature + Heatsink										