

mSATA

3ME2 Series

Customer: _____

Customer

Part

Number: _____

Innodisk

Part

Number: _____

Innodisk

Model Name: _____

Date: _____

Innodisk Approver	Customer Approver

**Total Solution For
Industrial Flash Storage**

Table of contents

LIST OF FIGURES	6
1. PRODUCT OVERVIEW	7
1.1 INTRODUCTION OF INNODISK MSATA 3ME2	7
1.2 PRODUCT VIEW AND MODELS	7
1.3 SATA INTERFACE.....	7
2. PRODUCT SPECIFICATIONS.....	8
2.1 CAPACITY AND DEVICE PARAMETERS.....	8
2.2 PERFORMANCE	8
2.3 ELECTRICAL SPECIFICATIONS	8
2.3.1 Power Requirement.....	8
2.3.2 Power Consumption	8
2.4 ENVIRONMENTAL SPECIFICATIONS	9
2.4.1 Temperature Ranges	9
2.4.2 Humidity.....	9
2.4.3 Shock and Vibration	9
2.4.4 Mean Time between Failures (MTBF)	9
2.5 CE AND FCC COMPATIBILITY	10
2.6 RoHS COMPLIANCE	10
2.7 RELIABILITY	10
2.8 TRANSFER MODE	10
2.9 PIN ASSIGNMENT	10
2.10 MECHANICAL DIMENSIONS.....	12
2.11 ASSEMBLY WEIGHT	12
2.12 SEEK TIME	12
2.13 NAND FLASH MEMORY.....	12
3. THEORY OF OPERATION	13
3.1 OVERVIEW.....	13
3.2 SATA III CONTROLLER	13
3.3 ERROR DETECTION AND CORRECTION.....	13
3.4 WEAR-LEVELING	14
3.5 BAD BLOCKS MANAGEMENT	14
3.6 POWER CYCLING	14
3.7 GARBAGE COLLECTION.....	14
3.8 TRIM	14
4. INSTALLATION REQUIREMENTS	15
4.1 MSATA 3ME2 PIN DIRECTIONS.....	15

4.2 ELECTRICAL CONNECTIONS FOR MSATA 3ME2	15
4.3 DEVICE DRIVE	15
5. PART NUMBER RULE	16

REVISION HISTORY

Revision	Description	Date
Preliminary	First Released	Feb., 2015
1.0	Modify the controller name from ID172 to ID202	May.,2015
1.01	Added Trim information	May., 2015
1.1	Update Mechanical drawing Update power consumption	July, 2015
1.2	Add 512GB and update performance, power consumption	Jan, 2016

List of Tables

TABLE 1: DEVICE PARAMETERS	8
TABLE 2: PERFORMANCE	8
TABLE 3: INNODISK mSATA 3ME2 POWER REQUIREMENT	8
TABLE 4: POWER CONSUMPTION	8
TABLE 5: TEMPERATURE RANGE FOR mSATA 3ME2	9
TABLE 6: SHOCK/VIBRATION TESTING FOR mSATA 3ME2	9
TABLE 7: mSATA 3ME2 MTBF	9
TABLE 8: INNODISK mSATA 3ME2 PIN ASSIGNMENT	10

List of Figures

FIGURE 1: INNODISK mSATA 3ME2	7
FIGURE 2: INNODISK mSATA 3ME2 BLOCK DIAGRAM	13
FIGURE 3: SIGNAL SEGMENT AND POWER SEGMENT	15

1. Product Overview

1.1 Introduction of Innodisk mSATA 3ME2

Innodisk mSATA 3ME2 is designed with mSATA form factor by MO-300/MO-300B which established by JEDEC, and supports SATA III standard (6.0Gb/s) with excellent performance. Regarding of mechanical interference, Innodisk mSATA 3ME2 absolutely replaces the traditional hard disk and makes personal computer, in any field, smaller and easier.

Innodisk mSATA 3ME2 effectively reduces the booting time of operation system and the power consumption is less than hard disk drive (HDD), and complies with ATA protocol, no additional drives are required, and can be configured as a boot device or data storage device

1.2 Product View and Models

Innodisk mSATA 3ME2 is available in follow capacities within MLC flash ICs.

[mSATA 3ME2 16GB](#)

[mSATA 3ME2 32GB](#)

[mSATA 3ME2 64GB](#)

[mSATA 3ME2 128GB](#)

[mSATA 3ME2 256GB](#)

[mSATA 3ME2 512GB](#)

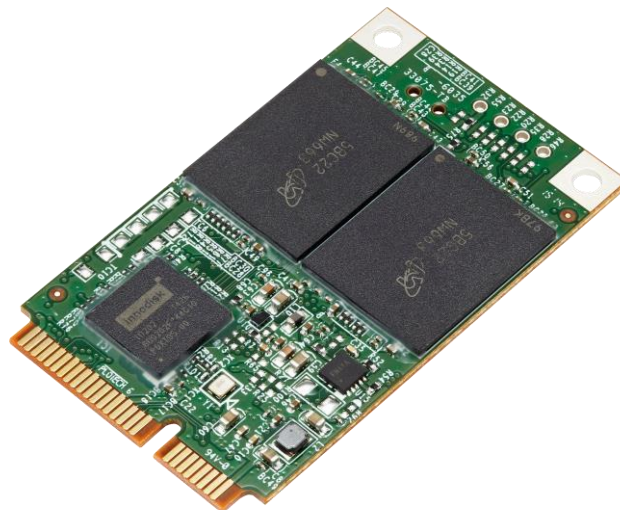

Figure 1: Innodisk mSATA 3ME2

1.3 SATA Interface

Innodisk mSATA 3ME2 supports SATA III(6.0Gb/s) interface, and compliant with SATA I (1.5Gb/s) and SATA II(3.0Gb/s).

2. Product Specifications

2.1 Capacity and Device Parameters

mSATA 3ME2 device parameters are shown in Table 1.

Table 1: Device parameters

Capacity	Cylinders	Heads	Sectors	LBA	User Capacity(MB)
16GB	16383	16	63	31277232	15,272
32GB	16383	16	63	62533296	30,533
64GB	16383	16	63	125045424	61,057
128GB	16383	16	63	250069680	122,104
256GB	16383	16	63	500118192	244,198
512GB	16383	16	63	1000215216	488,386

2.2 Performance

Burst Transfer Rate: 6.0Gbps

Table 2: Performance

Capacity	16GB	32GB	64GB	128GB	256GB	512GB
Sequential Read (max.)	120 MB/sec	250 MB/sec	510 MB/sec	510 MB/sec	510 MB/sec	510 MB/sec
Sequential Write (max.)	20 MB/sec	40 MB/sec	80 MB/sec	160 MB/sec	270 MB/sec	280 MB/sec
4KB Random** Read (QD32)	5,600 IOPS	11,000 IOPS	22,000 IOPS	29,000 IOPS	34,000 IOPS	34,000 IOPS
4KB Random** Write (QD32)	4,800 IOPS	9,700 IOPS	19,000 IOPS	40,000 IOPS	62,000 IOPS	63,000 IOPS

Note: the information is based on CrystalDiskMark 3.01 with file size 1000MB test patent

2.3 Electrical Specifications

2.3.1 Power Requirement

Table 3: Innodisk mSATA 3ME2 Power Requirement

Item	Symbol	Rating	Unit
Input voltage	V _{IN}	+3.3 DC +- 5%	V

2.3.2 Power Consumption

Table 4: Power Consumption

Mode	Power Consumption (mA)
Read	350 (max.)
Write	680 (max.)
Idle	49 (max.)

* Target: 512GB mSATA 3ME2

2.4 Environmental Specifications

2.4.1 Temperature Ranges

Table 5: Temperature range for mSATA 3ME2

Temperature	Range
Operating	Standard Grade: 0°C to +70°C
	Industrial Grade: -40°C to +85°C
Storage	-55°C to +95°C

2.4.2 Humidity

Relative Humidity: 10-95%, non-condensing

2.4.3 Shock and Vibration

Table 6: Shock/Vibration Testing for mSATA 3ME2

Reliability	Test Conditions	Reference Standards
Vibration	7 Hz to 2K Hz, 20G, 3 axes	IEC 68-2-6
Mechanical Shock	Duration: 0.5ms, 1500 G, 3 axes	IEC 68-2-27

2.4.4 Mean Time between Failures (MTBF)

Table 7 summarizes the MTBF prediction results for various mSATA 3ME2 configurations. The analysis was performed using a RAM Commander™ failure rate prediction.

- **Failure Rate:** The total number of failures within an item population, divided by the total number of life units expended by that population, during a particular measurement interval under stated condition.
- **Mean Time between Failures (MTBF):** A basic measure of reliability for repairable items: The mean number of life units during which all parts of the item perform within their specified limits, during a particular measurement interval under stated conditions.

Table 7: mSATA 3ME2 MTBF

Product	Condition	MTBF (Hours)
Innodisk mSATA 3ME2	Telcordia SR-332 GB, 25°C	>3,000,000

2.5 CE and FCC Compatibility

mSATA 3ME2 conforms to CE and FCC requirements.

2.6 RoHS Compliance

mSATA 3ME2 is fully compliant with RoHS directive.

2.7 Reliability

Parameter	Value
Read Cycles	Unlimited Read Cycles
Wear-Leveling Algorithm	Support
Bad Blocks Management	Support
Error Correct Code	Support
TBW (Total Byte written)	Unit: Terabyte
16GB	4.8
32GB	9.6
64GB	19.2
128GB	38.4
256GB	76.8
512GB	153.6
* Total bytes written is based on JEDEC 218 (Solid-State Drive requirements and Endurance Test Method)	
** Lifespan is calculated by device written per day.	

2.8 Transfer Mode

mSATA 3ME2 support following transfer mode:

Serial ATA III 6.0Gbps

Serial ATA II 3.0Gbps

Serial ATA I 1.5Gbps

2.9 Pin Assignment

Innodisk mSATA 3ME2 uses a standard SATA pin-out. See Table 8 for mSATA 3ME2 pin assignment.

Table 8: Innodisk mSATA 3ME2 Pin Assignment

Signal Name	Pin #	Pin #	Signal Name
GND	51	52	+3.3V

DAS	49	50	GND
NC	47	48	NC
NC	45	46	NC
NC	43	44	DEVSLP
+3.3V	41	42	NC
+3.3V	39	40	GND
GND	37	38	NC
GND	35	36	NC
RX+	33	34	GND
RX-	31	32	NC
GND	29	30	NC
GND	27	28	NC
TX-	25	26	GND
TX+	23	24	+3.3V
GND	21	22	NC
NC	19	20	NC
NC	17	18	GND
GND	15	16	NC
NC	13	14	NC
NC	11	12	NC
GND	9	10	NC
NC	7	8	NC
NC	5	6	NC
NC	3	4	GND
NC	1	2	+3.3V

2.10 Mechanical Dimensions

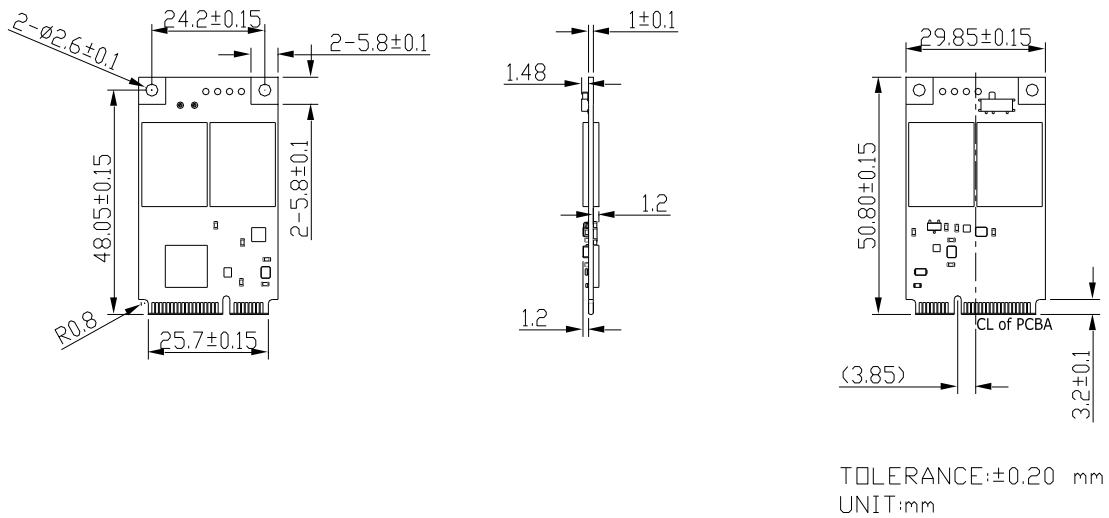

2.11 Assembly Weight

An Innodisk mSATA 3ME2 with flash ICs, 32GB's weight is 8 grams approximately.

2.12 Seek Time

Innodisk mSATA 3ME2 is not a magnetic rotating design. There is no seek or rotational latency required.

2.13 NAND Flash Memory

Innodisk mSATA 3ME2 uses Multi Level Cell (MLC) NAND flash memory, which is non-volatility, high reliability and high speed memory storage. Each cell stores 2 bits or holds four states per cell. Read or Write data to flash memory for SSD is control by microprocessor.

3. Theory of Operation

3.1 Overview

Figure 2 shows the operation of Innodisk mSATA 3ME2 from the system level, including the major hardware blocks.

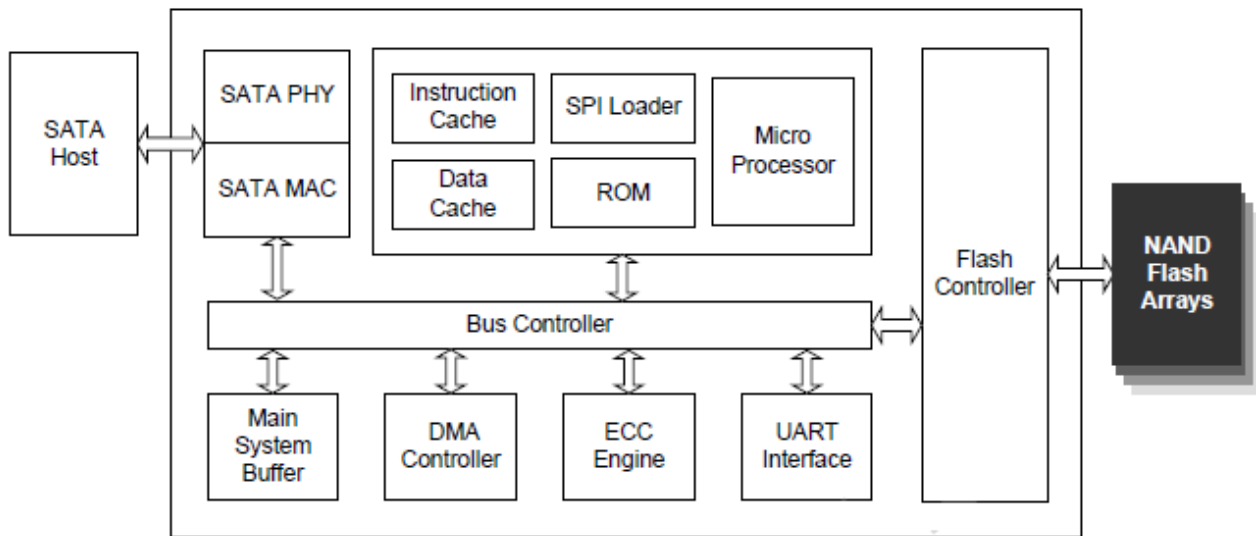

Figure 2: Innodisk mSATA 3ME2 Block Diagram

Innodisk mSATA 3ME2 integrates a SATA III controller and NAND flash memories. Communication with the host occurs through the host interface, using the standard ATA protocol. Communication with the flash device(s) occurs through the flash interface.

3.2 SATA III Controller

Innodisk mSATA 3ME2 is designed with ID 202 , a SATA III 6.0Gbps (Gen. 3) controller. The Serial ATA physical, link and transport layers are compliant with Serial ATA Gen 1, Gen 2 and Gen 3 specification (Gen 3 supports 1.5Gbps/3.0Gbps/6.0Gbps data rate). The controller has 2 / 4 channels for flash interface.

3.3 Error Detection and Correction

Highly sophisticated Error Correction Code algorithms are implemented. The ECC unit consists of the Parity Unit (parity-byte generation) and the Syndrome Unit (syndrome-byte computation). This unit implements an algorithm that can correct 66 bits per 1024 bytes in an ECC block. Code-byte generation during write operations, as well as error detection during read operation, is

implemented on the fly without any speed penalties.

3.4 Wear-Leveling

Flash memory can be erased within a limited number of times. This number is called the **erase cycle limit** or **write endurance limit** and is defined by the flash array vendor. The erase cycle limit applies to each individual erase block in the flash device.

Innodisk mSATA 3ME2 uses a static wear-leveling algorithm to ensure that consecutive writes of a specific sector are not written physically to the same page/block in the flash. This spreads flash media usage evenly across all pages, thereby extending flash lifetime.

3.5 Bad Blocks Management

Bad Blocks are blocks that contain one or more invalid bits whose reliability are not guaranteed. The Bad Blocks may be presented while the SSD is shipped, or may develop during the life time of the SSD. When the Bad Blocks is detected, it will be flagged, and not be used anymore. The SSD implement Bad Blocks management, Bad Blocks replacement, Error Correct Code to avoid data error occurred. The functions will be enabled automatically to transfer data from Bad Blocks to spare blocks, and correct error bit.

3.6 Power Cycling

Innodisk's power cycling management is a comprehensive data protection mechanism that functions before and after a sudden power outage to SSD. Low-power detection terminates data writing before an abnormal power-off, while table-remapping after power-on deletes corrupt data and maintains data integrity. Innodisk's power cycling provides effective power cycling management, preventing data stored in flash from degrading with use.

3.7 Garbage Collection

Garbage collection is used to maintain data consistency and perform continual data cleansing on SSDs. It runs as a background process, freeing up valuable controller resources while sorting good data into available blocks, and deleting bad blocks. It also significantly reduces write operations to the drive, thereby increasing the SSD's speed and lifespan.

3.8 Trim

The Trim command is designed to enable the operating system to notify the SSD which pages no longer contain valid data due to erases either by the user or operating system itself. During a delete operation, the OS will mark the sectors as free for new data and send a Trim command to the SSD to mark them as not containing valid data. After that the SSD knows not to preserve the

contents of the block when writing a page, resulting in less write amplification with fewer writes to the flash, higher write speed, and increased drive life.

4. Installation Requirements

4.1 mSATA 3ME2 Pin Directions

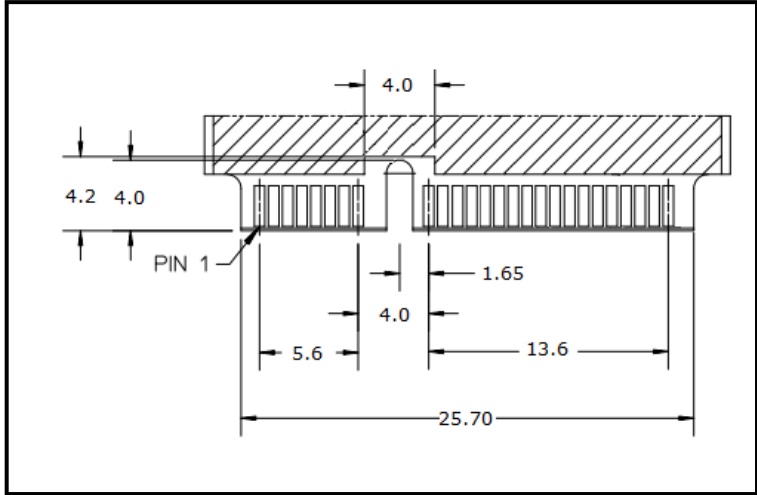

Figure 3: Signal Segment and Power Segment

4.2 Electrical Connections for mSATA 3ME2

A Serial ATA device may be either directly connected to a host or connected to a host through an adaptor card. The SATA interface has a separate connector for the power supply. Please refer to the pin description for further details.

4.3 Device Drive

No additional device drives are required. The Innodisk mSATA 3ME2 can be configured as a boot device.

5. Part Number Rule

CODE	1	2	3	4	5	6	7	8	9	10	11	12	13	14	15	16	17	18	19	20	21
	D	E	M	S	R	-	3	2	G	D	7	2	S	C	A	D	N	-	X	X	X
Description	Disk	mSATA Regular			Capacity			Controller		Flash Mode	Operation Temp.	Internal Control	CH	Flash Type	-	Customized Code					
Definition																					
Code 1st (Disk)											Code 13th (Flash Mode)										
D : Disk											S: Sync. Flash										
Code 2nd ~ 5th (Form Factor)											Code 14th (Operation Temperature)										
EMSR: mSATA Regular											C: Standard Grade (0°C ~ +70°C)										
											W:Industrial Grade (-40°C ~ +85°C)										
Code 7th ~9th (Capacity)											Code 15th (Internal control)										
16G: 16GB											A~Z: BGA PCB version										
32G: 32GB											Code 16th (Channel of data transfer)										
64G: 64GB											S: Single Chanel										
A28: 128GB											D: Dual Channels										
B56: 256GB											Q:Quad Channels										
C12: 512GB											Code 17th (Flash Type)										
Code 10th ~12th (Controller)											N: Micron MLC										
D72: ID202											Code 19th~21th (Customized Code)										

宜鼎國際股份有限公司 Innodisk Corporation

Tel:(02)7703-3000 Fax:(02) 7703-3555 Internet: <http://www.innodisk.com/>

REACH Declaration of Conformity

Manufacturer Product: All Innodisk EM Flash and Dram products

1.宜鼎國際股份有限公司（以下稱本公司）特此保證此售予貴公司之產品，皆符合歐盟化學品法案(Registration , Evaluation and Authorization of Chemicals ; REACH)之規定

(<http://www.echa.europa.eu/de/candidate-list-table> last updated: 16/05/2014)。所提供之產品包含：(1) 產品或產品所使用到的所有原物料；(2) 包裝材料；(3) 設計、生產及重工過程中所使用到的所有原物料。

We Innodisk Corporation hereby declare that our products are in compliance with the requirements according to the REACH Regulation

(<http://www.echa.europa.eu/de/candidate-list-table> last updated: 16/06/2014).

Products include : 1) Product and raw material used by the product ; 2) Packaging material ; 3) Raw material used in the process of design, production and rework

2.本公司同意因本保證書或與本保證書相關事宜有所爭議時，雙方宜友好協商，達成協議。

InnoDisk Corporation agrees that both parties shall settle any dispute arising from or in connection with this Declaration of Conformity by friendly negotiations.

立 保 證 書 人 (Guarantor)

Company name 公司名稱： InnoDisk Corporation 宜鼎國際股份有限公司

Company Representative 公司代表人： Richard Lee 李鐘亮

Company Representative Title 公司代表人職稱： CEO 執行長

Date 日期： 2014 / 07 / 29





宜鼎國際股份有限公司 Innodisk Corporation

Tel:(02)7703-3000 Fax:(02) 7703-3555 Internet: <http://www.innodisk.com/>

RoHS 自我宣告書 (RoHS Declaration of Conformity)

Manufacturer Product: All Innodisk EM Flash and Dram products

一、 宜鼎國際股份有限公司 (以下稱本公司) 特此保證售予貴公司之所有產品, 皆符合歐盟 2011/65/EU 關於 RoHS 之規範要求。

Innodisk Corporation declares that all products sold to the company, are complied with European Union RoHS Directive (2011/65/EU) requirement

二、 本公司同意因本保證書或與本保證書相關事宜有所爭議時, 雙方宜友好協商, 達成協議。

Innodisk Corporation agrees that both parties shall settle any dispute arising from or in connection with this Declaration of Conformity by friendly negotiations.

Name of hazardous substance	Limited of RoHS ppm (mg/kg)
Cd	< 100 ppm
Pb	< 1000 ppm
Hg	< 1000 ppm
Chromium VI (Cr+6)	< 1000 ppm
Polybromodiphenyl ether (PBDE)	< 1000 ppm
Polybrominated Biphenyls (PBB)	< 1000 ppm

立保證書人 (Guarantor)

Company name 公司名稱: Innodisk Corporation 宜鼎國際股份有限公司

Company Representative 公司代表人: Richard Lee 李鍾亮

Company Representative Title 公司代表人職稱: CEO 執行長

Date 日期: 2014 / 07 / 29



Verification of Compliance

Product Name : mSATA
 Model Number : mSATA 3\$*#-&
 \$:Flash type: (S:SLC,I:iSLC,M:MLC)
 *: Product line: (E:Embedded, G: EverGreen)
 #:controller:
 (empty:606/607/667/670, 2: SMI 2246XT/ 2246EN, 3:608/609)
 &: Product feature: (P: with DRAM, empty: without DRAM)

Applicant : Innodisk Corporation
 Address : 5F.No.237, Sec. 1, Datong Rd., Xizhi Dist., New Taipei City 221, Taiwan (R.O.C.)
 Report Number : S3F-U070-1307-314
 Issue Date : December 10, 2014

Applicable Standards : FCC Part 15, Subpart B Class B ITE
 ANSI C63.4:2009
 Industry Canada ICES-003 Issue 5
 CAN/CSA-CISPR 22-10 Class B ITE

One sample of the designated product has been tested in our laboratory and found to be in compliance with the FCC rules cited above.



NVLAP LAB CODE 200575-0

TAF 0905

FCC CAB Code TW1053

IC Code 4699A

VCCI Accep. No. R-1527, C-1609, T-1441, G-10,

C-4400, T-1334, G-614



Central Research Technology Co.

EMC Test Laboratory

11, Lane 41, Fushuen St., Jungshan Chiu,

Taipei, Taiwan, 104, R.O.C.

Tel : 886-2-25984568

Fax: 886-2-25984546

(Tsun-Yu Shih/ General Manager)

Verification of Compliance

Product Name : mSATA
Model Number : mSATA 3\$*#-&
 \$:Flash type: (S:SLC,I:iSLC,M:MLC)
 *: Product line: (E:Embedded, G: EverGreen)
 #:controller:
 (empty:606/607/667/670, 2: SMI 2246XT/ 2246EN, 3:608/609)
 &: Product feature: (P: with DRAM, empty: without DRAM)

Applicant : Innodisk Corporation
Address : 5F.No.237, Sec. 1, Datong Rd., Xizhi Dist., New Taipei City 221, Taiwan (R.O.C.)
Report Number : S3O22-U070-1307-314
Issue Date : December 10, 2014
Applicable Standards : EN 55022:2010+AC:2011 Class B ITE
 AS/NZS CISPR22:2009+A1:2010 Class B ITE
 EN 55024:2010
 EN 61000-4-2:2009
 EN 61000-4-3:2006+A1:2008+A2:2010
 EN 61000-4-4:2004+A1:2010

Based on the EMC Directive 2004/108/EC and the specifications of the customer, one sample of the designated product has been tested in our laboratory and found to be in compliance with the EMC standards cited above.



TAF 0905
 FCC CAB Code TW1053
 NVLAP Lab Code 200575-0
 IC Code 4699A
 VCCI Accep. No. R-1527, C-1609, T-1441, G-10,
 C-4400, T-1334, G-614



Central Research Technology Co.
 EMC Test Laboratory
 11, Lane 41, Fushuen St., Jungshan Chiu,
 Taipei, Taiwan, 104, R.O.C.
 Tel : 886-2-25984568
 Fax: 886-2-25984546

(Tsun-Yu Shih/ General Manager)

Date: December 10, 2014