

M.2 (S42)

3TEA series

with Innodisk NAND

Customer: _____
Customer
Part Number: _____
Innodisk
Part Number: _____
Innodisk
Model Name: _____
Date: _____

Innodisk Approver	Customer Approver

Features:

- SATA III
- Innodisk 3D TLC NAND
- M.2 2242-D2-B+M
- Standard temperature
- Hybrid Write

Performance:

- Sequential Read up to 550 MB/s
- Sequential Write up to 470 MB/s

Power Requirements:

Input Voltage:	3.3V±5%
Max Operating Wattage:	1.9W
Idle Wattage:	0.4W

Reliability:

Capacity	TBW	DWPD
128GB	129	1.52
256GB	258	1.52
512GB	516	1.52

Data Retention	10 Years
Warranty	2 Years

For warranty details, please refer to:

https://www.innodisk.com/en/support_and_service/warranty

Table of contents

1. PRODUCT OVERVIEW	8
1.1 INTRODUCTION OF INNODISK M.2 (S42) 3TEA	8
1.2 PRODUCT VIEW AND MODELS	8
1.3 SATA INTERFACE	8
2. PRODUCT SPECIFICATIONS	9
2.1 CAPACITY AND DEVICE PARAMETERS	9
2.2 PERFORMANCE	9
2.3 ELECTRICAL SPECIFICATIONS	9
2.3.1 Power Requirement	9
2.3.2 Power Consumption	10
2.4 ENVIRONMENTAL SPECIFICATIONS	10
2.4.1 Temperature Ranges	10
2.4.2 Humidity	10
2.4.3 Shock and Vibration	10
2.4.4 Mean Time between Failures (MTBF)	10
2.5 CE AND FCC COMPATIBILITY	11
2.6 RoHS COMPLIANCE	11
2.7 RELIABILITY	11
2.8 TRANSFER MODE	11
2.9 PIN ASSIGNMENT	11
2.10 MECHANICAL DIMENSIONS	13
2.11 ASSEMBLY WEIGHT	13
2.12 SEEK TIME	13
2.13 HOT PLUG	13
2.14 NAND FLASH MEMORY	13
3. THEORY OF OPERATION	14
3.1 OVERVIEW	14
3.2 SATA III CONTROLLER	14
3.3 ERROR DETECTION AND CORRECTION	14
3.4 WEAR-LEVELING	15
3.5 BAD BLOCKS MANAGEMENT	15
3.6 GARBAGE COLLECTION	15
3.7 TRIM	15
4. INSTALLATION REQUIREMENTS	16
4.1 M.2 (S42) 3TEA PIN DIRECTIONS	16
4.2 ELECTRICAL CONNECTIONS FOR M.2 (S42) 3TEA	16
4.3 DEVICE DRIVE	16

5. SMART FEATURE SET	17
5.1 SMART ATTRIBUTES.....	17
6. PART NUMBER RULE	18

REVISION HISTORY

Revision	Description	Date
V1.0	Official Release	Sep., 2022
V1.1	Correct DWPD & Mechanical Diagram Update 256GB & Add 512GB Information	Dec., 2022
V1.2	Update TBW & DWPD	May, 2023

List of Tables

TABLE 1 : DEVICE PARAMETERS	9
TABLE 2 : PERFORMANCE- 112 LAYERS 3D TLC	9
TABLE 3 : INNODISK M.2 (S42) 3TEA POWER REQUIREMENT	9
TABLE 4 : TYPICAL POWER CONSUMPTION	10
TABLE 5 : TEMPERATURE RANGE FOR M.2 (S42) 3TEA WITH INNODISK NAND	10
TABLE 6 : SHOCK/VIBRATION TESTING FOR M.2 (S42) 3TEA	10
TABLE 7 : M.2 (S42) 3TEA MTBF	10
TABLE 8 : M.2 (S42) 3TEA TBW	11
TABLE 9 : INNODISK M.2 (S42) 3TEA PIN ASSIGNMENT	11
TABLE 10 : SMART ATTRIBUTE	17

List of Figures

FIGURE 1 : INNODISK M.2 (S42) 3TEA DIAGRAM	13
FIGURE 2 : INNODISK M.2 (S42) 3TEA BLOCK DIAGRAM	14
FIGURE 3 : SIGNAL SEGMENT AND POWER SEGMENT	16

1. Product Overview

1.1 Introduction of Innodisk M.2 (S42) 3TEA

Innodisk M.2 (S42) 3TEA is SATA III 6.0 Gb/s disk with 3D NAND Flash, incorporate advanced controllers with powerful LDPC technology that extended lifespan through reducing the bad block number happening.

In 3TEA series, Innodisk keep with outstanding high IOPS and NAND Flash management features like wear-levelling, garbage collection, ATA Security, etc. More important, we keep our attentive service & controlled product supply promise to value customer need in the market.

CAUTION *TRIM must be enabled.*

TRIM enables SSD's controller to skip invalid data instead of moving. It can free up significant amount of resources, extends the lifespan of SSD by reducing erase, and write cycles on the SSD. Innodisk's handling of garbage collection along with TRIM command improves write performance on SSDs.

1.2 Product View and Models

Innodisk M.2 (S42) 3TEA is available in follow capacities within 3D TLC flash ICs.

[M.2 \(S42\) 3TEA 128GB](#)

[M.2 \(S42\) 3TEA 256GB](#)

[M.2 \(S42\) 3TEA 512GB](#)

1.3 SATA Interface

Innodisk M.2 (S42) 3TEA supports SATA III interface. SATA III interface can work with Serial Attached SCSI (SAS) host system, which is used in server computer.

2. Product Specifications

2.1 Capacity and Device Parameters

M.2 (S42) 3TEA device parameters are shown in Table 1.

Table 1 : Device parameters

Capacity	LBA	Cylinders	Heads	Sectors	User Capacity (MB)
128GB	250069680	16383	16	63	122104
256GB	500118192	16383	16	63	244198
512GB	1000215216	16383	16	63	488386

2.2 Performance

Burst Transfer Rate: 6.0Gbps

Table 2 : Performance- 112 Layers 3D TLC

Capacity	Unit	128GB	256GB	512GB
Sequential ² Read (Q32T1)	MB/s	550	535	550
Sequential ² Write (Q32T1)		460	450	470
Sustained ³ Sequential Read (Avg.)		360	360	380
Sustained ³ Sequential Write (Avg.)		155	120	160
4KB Random ² Read (Q32T1)	IOPS	40,000	38,000	68,000
4KB Random ² Write (Q32T1)		73,000	73,000	75,000

Note:

1. Performance may vary based on various firmware version or test platform.
2. Performance results are based on CrystalDiskMark 6.0.2 with file size 1000MB of Queue Depth32.
3. Performance results are based on AIDA 64 v5.98 with block size 1MB of Linear Read & Write Test

2.3 Electrical Specifications

2.3.1 Power Requirement

Table 3 : Innodisk M.2 (S42) 3TEA Power Requirement

Item	Symbol	Rating	Unit
Input voltage	V _{IN}	+3.3 DC +- 5%	V

2.3.2 Power Consumption

Table 4 : Typical Power Consumption

Mode	Power Consumption (W)
Read (RMS) ¹	1.0
Write (RMS) ¹	1.0
Idle	0.4
Boot Up	1.9

2.4 Environmental Specifications

2.4.1 Temperature Ranges

Table 5 : Temperature range for M.2 (S42) 3TEA with Innodisk NAND

Temperature	Range
Operating	Standard Grade: 0°C to +70°C
Storage	-40°C to +85°C

2.4.2 Humidity

Relative Humidity: 10-95%, non-condensing

2.4.3 Shock and Vibration

Table 6 : Shock/Vibration Testing for M.2 (S42) 3TEA

Reliability	Test Conditions	Reference Standards
Vibration	7 Hz to 2K Hz, 20G, 3 axes	IEC 60068-2-6
Mechanical Shock	Duration: 0.5ms, 1500 G, 3 axes	IEC 60068-2-27

2.4.4 Mean Time between Failures (MTBF)

Table 7 summarizes the MTBF prediction results for various M.2 (S42) 3TEA configurations. The analysis was performed using a RAM Commander™ failure rate prediction.

- **Failure Rate:** The total number of failures within an item population, divided by the total number of life units expended by that population, during a particular measurement interval under stated condition.
- **Mean Time between Failures (MTBF):** A basic measure of reliability for repairable items: The mean number of life units during which all parts of the item perform within their specified limits, during a particular measurement interval under stated conditions.

Table 7 : M.2 (S42) 3TEA MTBF

Product	Condition	MTBF (Hours)
Innodisk M.2 (S42) 3TEA	Telcordia SR-332 GB, 25°C	>3,000,000

2.5 CE and FCC Compatibility

M.2 (S42) 3TEA conforms to CE and FCC requirements.

2.6 RoHS Compliance

M.2 (S42) 3TEA is fully compliant with RoHS directive.

2.7 Reliability

Table 8 : M.2 (S42) 3TEA TBW

Parameter		Value
Flash endurance		3,000 P/E cycles
Error Correct Code		Support
Data Retention		Under 40°C: 10 Years at Initial NAND Status; 1 Year at NAND Life End
TBW* (Total Bytes Written) Units: TB		
Capacity	Sequential workload	Client workload
128GB	341	129
256GB	682	258
512GB	1364	516
* Note: 1. Sequential: Mainly sequential write, tested by Vdbench. 2. Client: Follow JESD218 Test method and JESD219A Workload, tested by ULINK. 3. Based on out-of-box performance.		

2.8 Transfer Mode

M.2 (S42) 3TEA support following transfer mode:

Serial ATA III 6.0Gbps

Serial ATA II 3.0Gbps

Serial ATA I 1.5Gbps

2.9 Pin Assignment

Innodisk M.2 (S42) 3TEA uses a standard SATA pin-out. See Table 9 for M.2 (S42) 3TEA pin assignment.

Table 9 : Innodisk M.2 (S42) 3TEA Pin Assignment

Signal Name	Pin #	Pin #	Signal Name
		75	GND
3.3V	74	73	GND
3.3V	72	71	GND
3.3V	70	69	GND

NC	68	67	NC
Notch	66	65	Notch
Notch	64	63	Notch
Notch	62	61	Notch
Notch	60	59	Notch
NC	58		
NC	56	57	GND
NC	54	55	NC
NC	52	53	NC
NC	50	51	GND
NC	48	49	RX+
NC	46	47	RX-
NC	44	45	GND
NC	42	43	TX-
NC	40	41	TX+
DEVSLP	38	39	GND
NC	36	37	NC
NC	34	35	NC
NC	32	33	GND
NC	30	31	NC
NC	28	29	NC
NC	26	27	GND
NC	24	25	NC
NC	22	23	NC
NC	20	21	GND
Notch	18	19	Notch
Notch	16	17	Notch
Notch	14	15	Notch
Notch	12	13	Notch
DAS/DSS	10	11	NC
NC	8	9	NC
NC	6	7	NC
3.3V	4	5	NC
3.3V	2	3	GND
		1	GND

2.10 Mechanical Dimensions

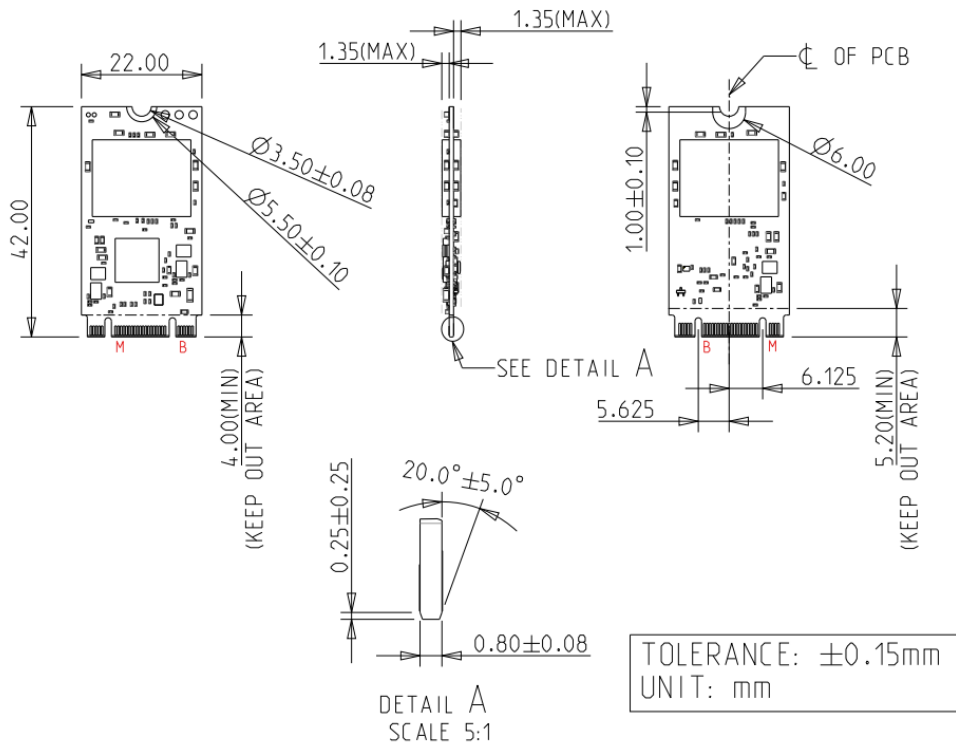

Figure 1 : Innodisk M.2 (S42) 3TEA diagram

2.11 Assembly Weight

An Innodisk M.2 (S42) 3TEA within flash ICs, 128GB's weight is 8 grams approximately.

2.12 Seek Time

Innodisk M.2 (S42) 3TEA is not a magnetic rotating design. There is no seek or rotational latency required.

2.13 Hot Plug

The SSD support hot plug function and can be removed or plugged-in during operation. User has to avoid hot plugging the SSD which is configured as boot device and installed operation system.

Surprise hot plug : The insertion of a SATA device into a backplane (combine signal and power) that has power present. The device powers up and initiates an OOB sequence.

Surprise hot removal: The removal of a SATA device from a powered backplane, without first being placed in a quiescent state.

2.14 NAND Flash Memory

Innodisk M.2 (S42) 3TEA uses 3D TLC NAND flash memory, which is non-volatility, high reliability and high speed memory storage.

3. Theory of Operation

3.1 Overview

Figure 2 shows the operation of Innodisk M.2 (S42) 3TEA from the system level, including the major hardware blocks.

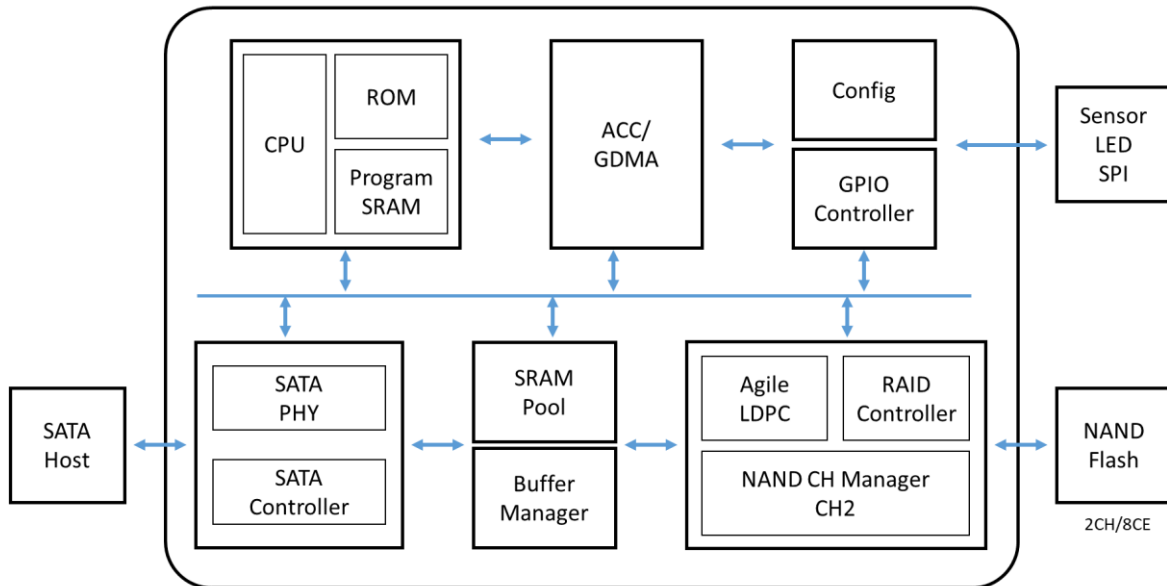

Figure 2 : Innodisk M.2 (S42) 3TEA Block Diagram

Innodisk M.2 (S42) 3TEA integrates a SATA III controller and NAND flash memories. Communication with the host occurs through the host interface, using the standard ATA protocol. Communication with the flash device(s) occurs through the flash interface.

3.2 SATA III Controller

Innodisk M.2 (S42) 3TEA is designed with SATA III 6.0Gbps (Gen. 3) Controller, a SATA III 6.0Gbps (Gen. 3) controller. The Serial ATA physical, link and transport layers are compliant with Serial ATA Gen 1, Gen 2 and Gen 3 specification (Gen 3 supports 1.5Gbps/3.0Gbps/6.0Gbps data rate). The controller has 2 channels for flash interface.

3.3 Error Detection and Correction

Innodisk 2.5" SATA SSD 3TEA is designed with hardware LDPC ECC engine with hard-decision and soft-decision decoding. Low-density parity-check (LDPC) codes have excellent error correcting performance close to the Shannon limit when decoded with the belief-propagation (BP) algorithm using soft-decision information.

3.4 Wear-Leveling

Flash memory can be erased within a limited number of times. This number is called the **erase cycle limit** or **write endurance limit** and is defined by the flash array vendor. The erase cycle limit applies to each individual erase block in the flash device.

Innodisk M.2 (S42) 3TEA uses a combination of two types of wear leveling- dynamic and static wear leveling- to distribute write cycling across an SSD and balance erase count of each block, thereby extending device lifetime.

3.5 Bad Blocks Management

Bad Blocks are blocks that contain one or more invalid bits whose reliability are not guaranteed. The Bad Blocks may be presented while the SSD is shipped, or may develop during the life time of the SSD. When the Bad Blocks is detected, it will be flagged, and not be used anymore. The SSD implement Bad Blocks management, Bad Blocks replacement, Error Correct Code to avoid data error occurred. The functions will be enabled automatically to transfer data from Bad Blocks to spare blocks, and correct error bit.

3.6 Garbage Collection

Garbage collection is used to maintain data consistency and perform continual data cleansing on SSDs. It runs as a background process, freeing up valuable controller resources while sorting good data into available blocks, and deleting bad blocks. It also significantly reduces write operations to the drive, thereby increasing the SSD's speed and lifespan.

3.7 Trim

The Trim command is designed to enable the operating system to notify the SSD which pages no longer contain valid data due to erases either by the user or operating system itself. During a delete operation, the OS will mark the sectors as free for new data and send a Trim command to the SSD to mark them as not containing valid data. After that the SSD knows not to preserve the contents of the block when writing a page, resulting in less write amplification with fewer writes to the flash, higher write speed, and increased drive life.

4. Installation Requirements

4.1 M.2 (S42) 3TEA Pin Directions

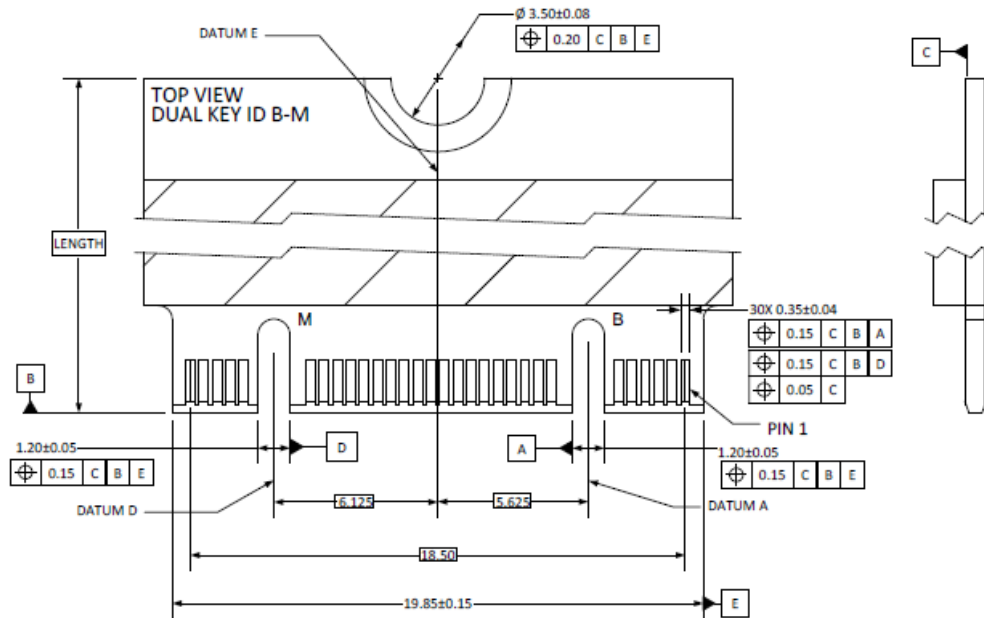

Figure 3 : Signal Segment and Power Segment

4.2 Electrical Connections for M.2 (S42) 3TEA

A Serial ATA device may be either directly connected to a host or connected to a host through a cable. For connection via cable, the cable should be no longer than 1meter. The SATA interface has a separate connector for the power supply. Please refer to the pin description for further details.

4.3 Device Drive

No additional device drives are required. The Innodisk M.2 (S42) 3TEA can be configured as a boot device.

5. SMART Feature Set

5.1 SMART Attributes

Innodisk 3TEA series SMART data attributes are listed in following table.

Table 10 : SMART attribute

ID	Attribute Name
05h	Reallocated Sector Count
09h	Power-On Hours
0Ch	Drive Power Cycle Count
A7h	SSD Protect Mode
A8h	PHY Error Count
A9h	Bad Block Count
ABh	Program Fail Count
ACH	Erase Fail Count
ADh	Erase Count
A Eh	Remap Count
AFh	Bad Cluster Table Count
B1h	Read Retry Count
B4h	Spare Block Count Left
BBh	Reported UNC Errors
C0h	Unexpected Power Loss Count
C2h	Temperature
C4h	Reallocated Event Count
C7h	UDMA CRC Error Count
CEh	Minimum Erase Count
CFh	Maximum Erase Count
D0h	Average Erase Count
D1h	Minimum Erase Count of SLC block
D2h	Maximum Erase Count of SLC block
D3h	Average Erase Count of SLC block
E7h	SSD Life Left
F1h	Write Sector Count
F2h	Read Sector Count
F5h	Bit Error Count

6. Part Number Rule

CODE	1	2	3	4	5	6	7	8	9	10	11	12	13	14	15	16	17	18	19	20	21
	D	E	M	2	4	-	A	2	8	D	Z	1	K	C	A	D	L	-	X	X	X
Description	Disk	M.2 2242			Capacity			Category		Flash mode	Operation Temp.	PCB	CH.	Flash	Customized Code						
Definition																					
Code 1st (Disk)											Code 13th (Flash Mode)										
D : Disk											K: 112 layers 3D TLC										
Code 2nd (Feature set)																					
E : Embedded series																					
Code 3rd ~5th (Form factor)											Code 14th (Operation Temperature)										
M24: M.2 Type 2242-D2-B-M											C: Standard Grade (0°C~ +70°C)										
Code 7th ~9th (Capacity)											Code 15th (Internal control)										
A28: 128GB											A: BGA PCBA version										
B56: 256GB																					
C12: 512GB											Code 16th (Channel of data transfer)										
											S: Single Channel										
											D: Dual Channels										
Code 10th ~12th (Controller)											Code 17th (Flash Type)										
DZ1: SATA 3TEA											L: Innodisk 3D TLC										
Code 19th~21th (Customized Code)																					